

DEPARTMENT OF THE ARMY TECHNICAL MANUAL

---

OPERATOR AND ORGANIZATIONAL  
MAINTENANCE MANUAL

ARMORED  
RECONNAISSANCE/AIRBORNE  
ASSAULT VEHICLE

FULL-TRACKED, 152-MM, M551  
2350-873 5408

---

HEADQUARTERS, DEPARTMENT OF THE ARMY  
JUNE 1966

This copy is a reprint which includes current pages from Changes I through 14 . Pen-and-ink changes to be made are listed. For Crew Operating and Maintenance Instructions, refer to TM 9-2350-23010-1, 29 November 1974, TM 9-2350-230-10/2-1, 31 March 1973, TM 9-2350-230-10-2-2, 31 March 1973, and TM 9-2350-230-102-3, 6 January 1974. For Organizational Maintenance of the Hull and Suspension, refer to TM 9-2350-230-20-1, 15 February 1975.

**WARNING**

**CARBON MONOXIDE POISONING CAN BE DEADLY**

**CARBON MONOXIDE IS A COLORLESS, ODORLESS, DEADLY POISONOUS GAS, WHICH, WHEN BREATHED, DEPRIVES THE BODY OF OXYGEN AND CAUSES SUFFOCATION. EXPOSURE TO AIR CONTAMINATED WITH CARBON MONOXIDE PRODUCES SYMPTOMS OF HEADACHE, DIZZINESS, LOSS OF MUSCULAR CONTROL, APPARENT DROWSINESS, COMA. PERMANENT BRAIN DAMAGE OR DEATH CAN RESULT FROM SEVERE EXPOSURE.**

**IT OCCURS IN THE EXHAUST FUMES OF FUEL-BURNING HEATERS AND INTERNAL COMBUSTION ENGINES AND BECOMES DANGEROUSLY CONCENTRATED UNDER CONDITIONS OF INADEQUATE VENTILATION. THE FOLLOWING PRECAUTIONS MUST BE OBSERVED TO INSURE THE SAFETY OF PERSONNEL WHENEVER THE PERSONNEL HEATER, MAIN OR AUXILIARY ENGINE OF ANY VEHICLE IS OPERATED FOR MAINTENANCE PURPOSES OR TACTICAL USE.**

- 1. DO NOT OPERATE HEATER OR ENGINE OF VEHICLE IN AN ENCLOSED AREA UNLESS IT IS ADEQUATELY VENTILATED.**
- 2. DO NOT IDLE ENGINE FOR LONG PERIODS WITHOUT MAINTAINING ADEQUATE VENTILATION IN PERSONNEL COMPARTMENTS.**
- 3. DO NOT DRIVE ANY VEHICLE WITH INSPECTION PLATES, COVER PLATES, ENGINE COMPARTMENT DOORS REMOVED UNLESS NECESSARY FOR MAINTENANCE PURPOSES.**
- 4. BE ALERT AT ALL TIMES DURING VEHICLE OPERATION FOR EXHAUST ODORS AND EXPOSURE SYMPTOMS. IF EITHER ARE PRESENT, IMMEDIATELY VENTILATE PERSONNEL COMPARTMENTS. IF SYMPTOMS PERSIST, REMOVE AFFECTED PERSONNEL FROM VEHICLE AND TREAT AS FOLLOWS: EXPOSE TO FRESH AIR; KEEP WARM; DO NOT PERMIT PHYSICAL EXERCISE; IF NECESSARY, ADMINISTER ARTIFICIAL RESPIRATION.**

**THE BEST DEFENSE AGAINST CARBON MONOXIDE POISONING IS ADEQUATE VENTILATION.**

**CAUTION: THE M8A3 AIR FILTER UNIT WILL NOT PROTECT CREW AGAINST CARBON MONOXIDE POISONING.**

**WARNING**

**DO NOT CHAMBER AMMUNITION UNTIL IMMEDIATELY BEFORE FIRING.**

**AMMUNITION LEFT TOO LONG IN A HOT WEAPON MAY RESULT IN HAZARDOUS CONDITIONS.**

**FIRE OR REMOVE AMMUNITION WITHIN FIVE MINUTES OF CHAMBERING.**



THE FOLLOWING PEN-AND-INK-CHANGES ARE TO BE MADE:

Wherever one of the following model numbers appears, make change as shown;

- XM551- -----to M551
- XM81E12 (without closed breech scavenger system) to M81
- XM81E12 (with closed breech scavenger system) to M81E1
- XM44 -----to XM44/XM44E1
- XM47 -----to M47
- XM48 -----to M48

"Grenade projector" should read "grenade launcher" wherever it appears.

CHANGE)  
 )  
No. 14 )

HEADQUARTERS,  
DEPARTMENT OF THE ARMY  
WASHINGTON, DC, 3 May 1976

Operator and Organizational Maintenance Manual:

**ARMORED RECONNAISSANCE/AIRBORNE ASSAULT VEHICLE:  
FULL-TRACKED, 152-MM, M551  
(2350-00-873-5408)  
AND M551A1  
(2350-00-140-5151)**

TM 9-2350-230-12, 1 June 1966, is changed as follows:

1. New or changed material is indicated by a vertical bar in the margin of the page.
2. Added or revised illustrations are indicated by a vertical bar adjacent to the identification number.
3. Remove old pages and insert new pages as indicated below.

Remove pages

vii and viii  
8-41 and 8-42  
8-80.3 and 8-80.4  
10-1 and 10-2  
10-5 thru 10-8.4  
None  
10-21 and 10-22  
10-29 and 10-30  
10-30.1 and 10-30.2  
10-31 and 10-32  
10-36.1 and 10-36.2  
11-9 and 11-10  
11-13 and 11-14  
11-19 thru 11-24.2  
11-27 and 11-28

Insert pages

vii and viii  
8-41 and 8-42  
8-80.3 and 8-80.4  
10-1 and 10-2  
10-5 thru 10-8.4  
10-8.5 thru 10-8.14  
10-21 and 10-22  
10-29 and 10-30  
None  
10-31 and 10-32  
10-36.1 and 10-36.2  
11-9 and 11-10  
11-13 and 11-14  
11-19 thru 11-24.2  
11-27 and 11-28

Remove pages

None  
11-39 and 11-40  
C-7 thru C-10.2  
C-27 and C-28

Insert pages

11-29 and 11-30  
11-39 and 11-40  
C-7 thru C-10.2  
C-27 and C-28

4. File this change sheet in the front of the publication for reference purposes.

By Order of the Secretary of the Army:

FRED C. WEYAND  
General, United States Army  
Chief of Staff

Official:

PAUL T. SMITH  
Major General, United States Army  
The Adjutant General

DISTRIBUTION:

To be distributed in accordance with DA Form 12-37 (qty rqr block no. 1025) organizational maintenance requirements for Armored Reconnaissance/Airborne Assault Vehicle M551 and M551A1.

**WARNING**

**DO NOT FIRE AMMUNITION WITHOUT AUTHORIZED FUZE.**

CONVENTIONAL 152 MILLIMETER PROJECTILES ARE ASSEMBLED TO HIGHLY FLAMMABLE, NONMETALLIC CARTRIDGE CASES. KEEP THIS AMMUNITION AWAY FROM OPEN FLAMES, LIGHTED CIGARETTES, SMOLDERING RESIDUE AND OTHER SOURCES OF IGNITION.

DO NOT TOUCH, MOVE OR OTHERWISE HANDLE DUDS.

NOTIFY EOD OF LOCATION.

---

**WARNING  
RADIATION HAZARD**

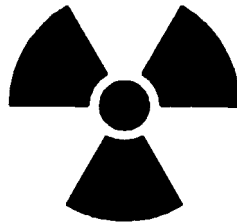

**AZIMUTH DIAL POINTERS ARE TIPPED WITH RADIOACTIVE MATERIAL.**

**HAZARDOUS RADIATION CONDITIONS EXIST WHEN DIAL WINDOW IS BROKEN OR REMOVED.**

**ALL MAINTENANCE MUST BE PERFORMED AT DEPOT LEVEL ONLY, EXCEPT FOR REPLACEMENT OF LAMPS AND REPLACEMENT OF COMPLETE INDICATOR UNIT.**

**PROTECTION, HANDLING, STORAGE, AND DISPOSAL OF RADIOACTIVE MATERIAL SHALL BE IN ACCORDANCE WITH TB-MED-232 AND TB 750-237.**

Technical Manual

No. 9-2350-230-12

HEADQUARTERS  
DEPARTMENT OF THE ARMY  
WASHINGTON, D. C., 1 June 1966

**Operator and Organizational Maintenance Manual  
ARMORED RECONNAISSANCE/AIRBORNE ASSAULT VEHICLE  
FUU-TRACKED, 152-MM, M551  
(2350-873-5408)**

TABLE OF CONTENTS

	Page
CHAPTER 1. INTRODUCTION	
Section 1-1. Scope, Security Classification, Maintenance Allocation, Records, Reports and Equipment Serviceability Criteria .....	1-1
1-2. Description and Data .....	1-1
1-3. Safety Precautions.....	1-6
CHAPTER 2. OPERATING INSTRUCTIONS	
Section 2-1. Service Upon Receipt of Materiel .....	2-1
Deprocessing Vehicle .....	2-1
Removal/Installation of Vehicle Closure Kit.....	2-2.3
Removal of Basic Issue Items Saddle .....	2-3
Installation of Retracting Slide Assembly on Cal. 50 Machine Gun, M2, HB .....	2-4
Installation of Pintle Support, Cradle and Pintle Assembly, and Cupola Mechanism Switch Assembly .....	2-5
break-in Services.....	2-6
2-2. Vehicle Operation.....	2-7
Starting, Driving, and Stopping Vehicle .....	2-7
Installation and Operation of Driver's M48 Periscope.....	2-12
Vehicle Driving Lights .....	2-13
Amphibious Operation .....	2-15
Erecting Flotation Surfboard and Barrier .....	2-18
Operation of Bilge Pumps.....	2-20.1
Cold Weather Starting .....	2-20.2
Towing Disabled Vehicle and Towing or Supplying Auxiliary Power to Start Engine .....	2-22
Installation of Two Shackles, Tow Bar or Tow Cables .....	2-23
2-3. Operation of Auxiliary Equipment .....	2-24
Operation of M8A3 Air Filter Unit .....	2-24
Operation of Personnel Heater.....	2-27
Operation of Portable and Fixed Fire Extinguishers.....	2-28
2-4. Operation of Turret and Cupola .....	2-29
Operation of Turret .....	2-29
Commander's Ballistic Shield Plate Assemblies .....	2-32.2
Operation of Cupola.....	2-33

	Page
CHAPTER 2.	OPERATING INSTRUCTIONS
Section 2-5.	Operation of Sighting and Fire Control and Armament Boresight Procedures .....2-35
	Operation of M119 or M127 Telescope, XM44 Series Periscope, and Armament Boresight Procedure .....2-36
	Aligning 7. 62MM Machine Gun .....2-40
	Operation of Indirect Fire Control Instruments .....2-43
	Checking and Adjusting Azimuth Indicator for Accuracy and Slippage .....2-44
	Adjusting M13AIC Elevation Quadrant.....2-45
	Installation, Operation, and Boresight Procedure for Cal.. 50 Machine Gun Night Vision Sight .....2-46
2-6.	Operation of Missile Subsystem .....2-48
	Energizing the Missile Subsystem .....2-48.1
	Lamp and Meter Test .....2-48.1
	Transmitter Test .....2-48.1
	Tracker Alignment Test .....2-49
	De-Energizing the Missile Subsystem .....2-50
2-7.	Operation of Special Purpose Kits .....2-53
	Winterization Kit Engine Coolant Heater .....2-53
	IR/Whitelight Searchlight Kit.....2-57
CHAPTER 3.	FIRING PROCEDURE
Section 3-1.	Misfire, Hangfire, and Cook-off, and Immediate Action in Case of Failure to Fire .....3-1
	152MM Conventional Ammunition.....3-2.1
	7. 62MM Machine Gun .....3-2.2
	Cal.. 50 Machine Gun, M2, HB.....3-3
3-2.	152MM Gun-Launcher.....3-4
	Loading, Firing, and Unloading .....3-5
	Checking and Adjusting Recoil Mechanism.....3-8
	Closed Breech Scavenger System Operation.....3-8.3
	Ammunition and Missile Stowage.....3-9
3-3.	7.62MM Machine Gun.....3-10.2
	Loading, Firing, and Unloading.....3-10.2
	7. 62MM Machine Gun Controls.....3-12
	Removal of Live Round or Ruptured Cartridge Case.....3-13
	Removal/Installation .....3-13
3-4.	Cal.. 50 Machine Gun, M2, HB .....3-14
	Loading, Firing and Unloading.....3-14
	Removal/Installation of Barrel .....3-15
	Removing Ruptured Cartridge Case .....3-17
	Removal/Installation Cal.. 50 Machine Gun Carrier Assembly.....3-17
	Checking and Adjusting Headspace .....3-18
	Checking and Adjusting Timing.....3-20
	Installation/Removal of Flash Hider.....3-22
	Removal/Installation Gun and Spent Brass Chute.....3-23
3-5.	M176 Grenade Launcher.....3-24
	Checking Electrical System.....3-24
	Immediate Action in Case of Failure to Fire.....3-25
	Loading and Firing.....3-25

CHAPTER 4.	CREW PREVENTIVE-MAINTENANCE SERVICES		
Section 4-1.	Preventive-Maintenance Services .....	4-1	
	Specific Procedures (Normal-Unusual Conditions) . . . . .	4-1	
	Hull Drain Holes.....	4-1	
4-2.	Lubrication .....	4-1	
	Service Intervals (Normal-Unusual Conditions) .....	4-1	
	Turret Floor Access Cover .....	4-10	
	Cleaning Crew Compartment .....	4-11	
	Checking Firing Probe Continuity .....	4-11	
	Deflating Blisters on CBS Hose .....	4-12	
	Low Pressure Air Radiator Cleaning System .....	4-12	
	Engine Bulkhead Access Panel .....	4-13	
CHAPTER 5.	CREW MAINTENANCE		
Section 5-1.	Repair Parts, Tools, and Equipment .....	5-1	
5-2.	Troubleshooting .....	5-1	
5-3.	Maintenance of Hull .....	5-9	
	Engine Air Cleaner.....	5-10	
	Power Plant.....	5-11	
	Fuel System and Batteries.....	5-12	
	Checking and Adjusting Track Tension .....	5-13	
	Removal/Installation of Track .....	5-14	
	Spare Lamps .....	5-15	
	Draining Coolant and Fuel Systems .....	5-17	
5-4.	Maintenance of Turret, Cupola, Sighting and Fire Control, and Missile Subsystem Units .....	5-19	
	Spare Lamps .....	5-19	
	Cleaning and Inspection - Sighting and Fire Control and Missile Subsystem Units.....	5-21	
	Removal/Installation - M47, M48 Periscopes .....	5-22	
5-5.	Maintenance of Armament.....	5-22.1	
	Checking and Servicing Countercoil Buffer .....	5-22.1	
	Removal/Installation - Evacuator Cylinder .....	5-22.2	
	Cleaning and Lubrication of Gun-Launcher .....	5-24.1	
	Disassembly/Assembly - 7. 62MM Machine Gun .....	5-24.2	
	Disassembly/Assembly - Cal.. 50 Machine Gun, M2, HB .....	5-29	
CHAPTER 6.	PREPARATION FOR AIR-DELIVERY, STORAGE AND DESTRUCTION OF MATERIEL TO PREVENT ENEMY USE		
Section 6-1.	Preparation for Air-Delivery .....	6-1	
6-2.	Storage.....	6-3	
	Servicing and Processing Vehicle for Storage .....	6-3	
	Missile Shipment and Storage.....	6-3	
6-3.	Destruction of Materiel to Prevent Enemy Use .....	6-4	
	Destruction Methods and Priority.....	6-4	
CHAPTER 7.	MATERIEL USED IN CONJUNCTION WITH MAJOR ITEM		
Section 7-1.	152MM Gun-Launcher Guided Missiles .....	7-1	
	Firing Tables and Precautions .....	7-1	
	Shillelagh Ammunition Data Chart .....	7-1	
	Service Upon Receipt of Missiles .....	7-2	
	Periodic Inspection of Missiles .....	7-4	
	Missile Identification.....	7-4	

CHAPTER	7	MATERIEL USED IN CONJUNCTION WITH MAJOR ITEM Continued	
Section	7-2.	Conventional Ammunition for 152MM Gun-Launcher M81 Series .....	7-4.1
		Identification.....	7-4.1
		Authorized Rounds .....	7- 4.1
		Preparation for Loading .....	7-4.1
		Round Types Available .....	7-4.5
		Preparation for Firing .....	7-4.7
		Cartridges Prepared for Firing But Not Fired .....	7-4.7
		Maintenance .....	7-4.7
		Storage .....	7-4.9
	7-3.	Communications Equipment.....	7-5
		Communications Data .....	7-5
		Radio Sets AN/VRC (Basic Units) and Intercommunication Equipment .....	7-6
CHAPTER	8	ORGANIZATIONAL MAINTENANCE INSTRUCTIONS	
Section	8-1.	General .....	8-1
	8-2.	Troubleshooting .....	8-8
		Transmission Oil Pressure Check Points .....	8-10
		Ohmmeter Method of Electrical Troubleshooting .....	8-45
		Odometer, Speedometer and Tachometer Troubleshooting.....	8-74.1
	8-3	Organizational Preventive-Maintenance Checks and Services . . . . .	8-75
		Preventive-Maintenance Checks and Services - Primary Armament and Related Equipment .....	8-85
CHAPTER	9	ORGANIZATIONAL MAINTENANCE - POWER PLANT AND HULL	
	Section.....		9-1
		Power Plant Removal/Installation/Replacement data.....	9-1
		Power Plant Removal/Installation .....	9-5
		Engine Mounts .....	9-10
		Engine Ground Test.....	9-12
	9-2.	Engine and Components .....	9-13
		Engine Fuel System.....	9-14
		Engine Coolant System .....	9-14
		Filter and Air Cleaner Removal Installation.....	9-28.1
		Blower Assembly and Hose Removal Installation.....	9-28.2
		Hull Wiring Harnesses Removal Installation.....	9-28.3
		Engine Wiring Harness Removal Installation .....	9-28.4
	9-3.	Transmission and Controls .....	9-42
		Transmission Internal Brake Adjustment. ....	9-43
		Accelerator/Throttle Linkage Adjustment.....	9-46.2
		Accelerator/Throttle Control Disassembly .....	9-48
		Transmission Shift Control Removal .....	9-50
		Transmission Shift Control Adjustment .....	9-52
		Transmission Brake Control Adjustment .....	9-52.2
		Transmission Parking Brake Control Removal/Installation and Adjustment .....	9-54
		Transmission Brake Control Removal/Installation .....	9-55
		Transmission Land Steer Control Removal/Installation.....	9-58
		Transmission Land Steer Control Adjustment .....	9-60
		Transmission Water Steer Control Removal/Installation .....	9-62
		Transmission Water Steer Control Adjustment .....	9-64
		Control Handling Precautions .....	9-65



CHAPTER 9 ORGANIZATIONAL MAINTINANCE - AND PLANT AND HULL  
Continued

Section 9-4.	Tracks and Suspension .....	9-66
	Roadwheels .....	9-69
	Torsion Bar and Roadwheel Arm Removal/Installation .....	9-70
	Torsion Bar Anchor Removal/Installation .....	9-71
	Roadwheel Arm Spindle. Disassembly/Assembly .....	9-72
	Roadwheel Arm Housing and Shaft Disassembly/Assembly.....	9-73
	Track Adjuster Removal/Installation .....	9-75
	Idler Wheels Removal/Installation.....	9-76
	Idler Hub Assembly Removal/Installation .....	9-17
	Idler Housing and Spindle Removal/Installation .....	9-78
	Sprocket Drive Shafts Removal/Installation.....	9-79
	Sprocket and Carrier Wheels Removal/Installation .....	9-80
	Sprocket Hub and Support Removal/Installation .....	9-81
	Shock Absorber Removal/Installation .....	9-82
	Suspension System Special Tools .....	9-84
	Track and Track Shoe Replacement .....	9-88
9-5.	Hull and Power Plant Electrical.....	9-90
	Headlight Adjustment.....	9-95
	Headlight Repair .....	9-96
	Taillight Repair .....	9-100
	Headlight Dimmer Switch and Auxiliary Power Receptacle,.....	9-102
	Dome Lights.....	9-103
	Batteries.....	9-105
	Fuel Level Transmitters .....	9-106
	Starter Relay, Neutral Safety and Water Steer Switches, and Hull Circuit Breakers Removal/Installation .....	9-107
	Driver's Switch Panel.....	9-108
	Driver's Switch Panel Rectifier.....	9-110.1
	Time Delay Assembly .....	9-110.2
	Turret Master Relay .....	9-110.3
	Electrical Harnesses .....	9-110.4
	Driver's Indicator Panel.....	9-113
	Personnel Heater Control Box, ? .....	9-114
	Bilge Pump Relays and Mounts ,.....	9-115
	Generator V-Belt Tensioner .....	9-115
	Voltage Regulator Removal/Installation/Adjustment.....	9-116
	Generator and Drive Assy. Removal/Installation .....	9-117
	Engine Starter Removal/Installation.....	9-119
	Temperature and Pressure Switches and Transmitters .....	9-120
	Speedometer and Tachometer Generators and Odometer Adapter Removal/Installation .....	9-121
	Odometer and Tachometer Drives .....	9-122
	Cable Terminals and Connectors Replacement.....	9-123
9-6.	Hull and Components .....	9-125
	Surfboard and Barrier Supports Adjustment.....	9-125
	Surfboard and Barrier Disassembly/Repair/Assembly.....	9-125
	Driver's Rotatable Hatch Latch Release and Latch tops .....	9-126.6
	Driver's Rotatable Hatch 8eals .....	9-127
	Driver's Escape Hatch .....	9-128
	Driver's Seat . .....	9-128.2
	Hull Ammunition Racks.....	9-131
	Bilge Pumps.....	9-134
	Personnel Heater Removal/Installation/Repair.....	9-137

CHAPTER 9	ORGANIZATIONAL MAINTENANCE POWER PLANT AND HULL Continued	
Section 9-6	Hull and Components - Continued	
	Fixed Fire Extinguisher Cylinder Replacement and Control Cable Adjustment .....	9-144
	Fixed Fire Extinguisher Control System Repair .....	9-145
	Radiator Contamination Shield and Grille Debris Screens Removal/Installation.....	9-146.1
	Battery and Air Cleaner Access Doors .....	9-146.2
	Ground Intercom Box Door Assembly .....	9-147
	Hull Interior Stowage.....	9-148.2
	Flotation Skin Repair .....	9-152
	Flotation Barrier Repair .....	9-153
CHAPTER 10.	ORGANIZATIONAL MAINTENANCE - TURRET AND CUPOLA	
Section 10-1	Turret Electrical Systems.....	10-1
10-2	Electrical Drive Control System .....	10-1
	Turret Drive Control Checkout Procedure Using Test Set.....	10-5
	Turret Drive Control Test Set Installation.....	10-8.4
	Accessory Box Removal/Installation/Adjustment.....	10-8.4
	Accessory Box Repair.....	10-9
	Amplifier Integrator Removal/Installation . . . . .	10-10
	Motor Generator Removal/Installation .....	10-10.1
	Motor Generator Brushes Removal/Installation .....	10-10.2
	Gunner's and Commander's Control Handle Removal/Installation .....	10-12
	Power Supply and Gyro Selector Removal/Installation.....	10-13
	Elevating and Traverse Mechanism Clutch Brush Removal/Installation.....	10-14
	Servo Motors Elevating and Traverse Removal/Installation . . . . .	10-14
	Gun-Launcher Elevation and Depression Bump Stop Adjustment.....	10-15
10-3	Conventional Weapons System.....	10-17
	Relay Box Removal/Installation .....	10-17
	Breech Scavenging Repeat Switch.....	10-17
	Loader's Control Box Removal/Installation.....	10-17
	Blasting Machine Removal/Installation .....	10-18
	Telescope Emergency Power Supply Box Removal/ Installation.....	10-18
	120V Firing Circuit Power Supply Box Removal/ Installation .....	10-18.1
	Low Pressure Air Radiator Cleaning System Removal/Installation .....	10-18.1
	Breech Scavenging Compressor Removal/Installation.....	10-19
	Chemical Air Drier Cartridge Removal/Installation .....	10-20.2
	Compressor Air Intake Strainer Removal/Installation .....	10-20.2
	Dipstick and Oil Strainer Removal/Installation.....	10-20.3
10-4.	Missile Subsystem	
	Checks and Adjustments . . . . .	10-20.4
	Signal Data Converter and Modulator Removal/Installation . . . . .	10-23
	Infrared Transmitter Cover Removal/Installation and Disassembly/Assembly of Door Latch and Control Assemblies.....	10-24.2
	Infrared Transmitter and Door Switch Removal/ Installation.....	10-26
	Missile Subsystem Power Supply Removal/Installation.....	10-27
	Rate Sensing Unit Removal/Installation.....	10-27

CHAPTER	10.	ORGANIZATIONAL MAINTENANCE - TURRET AND CUPOLA .....	Continued
Section	10-4	Missile Subsystem - Continued	
		Missile Subsystem Test Set Removal/Installation.....	10-28
		Optical Tracker Removal/Installation .....	10-28
	10-5.	Accessory and Power System . .....	10-29
		Circuit Cutout Box Removal/Installation.....	10-29
		Electric Contact Ring Removal/Installation.....	10-30
		Gas-Particulate Filter Unit Removal/Installation.....	10-32
		Radio Antenna Removal/Installation .....	10-34
		Cupola Power Box and Control Assembly Removal/ Installation.....	10-35
		Turret Ventilating Fan Removal/Installation .....	10-36
		Grenade Launcher 120V Power Supply Removal/ Installation.....	10-36
	10-6.	Turret Components .....	10-36.2
		Turret Traverse Lock Removal/Installation .....	10-37
		7. 62-,MM Coaxial Machine Gun Feed System Removal/ Installation/Repair .....	10-38
		Commander's Seat Removal/Installation .....	10-38
		Gunner's Seat Removal/Installation.....	10-40
		Loader's Seat Removal/Installation.....	10-42
		Turret Cable Guards Removal/Installation .....	10-43
		Loader's Hatch Cover.....	10-44
		Turret Conventional Ammunition Horizontal Racks Removal/Installation.....	10-45
		Turret Conventional Ammunition Vertical Racks Removal/Installation.....	10-46
		Turret Missile Rack, Portable Fire Extinguisher, and Extinguisher and Hose Guard Bracket Removal/ Installation .....	10-47
		Cupola Vision Blocks Removal/Installation.....	10-48
		Gunner's Leg Guard and Pad Removal/Installation .....	10-48
		Telescope Protective Shield Removal/Installation.....	10-48.3
		Cal .50 Maching Gun Mount Support Disassembly/ Assembly.....	10-48.3
		Commander's Ballistic Shield Plate Assemblies.....	10-48.4
		Turret Interior Stowage .....	10-48.6
		Turret Exterior Stowage.....	10-49
CHAPTER	11.	ORGANIZATIONAL MAINTENANCE - ARMAMENT AND FIRE CONTROL	
Section	11-1.	Primary Armament .....	11-1
		Firing Mechanism Continuity Check .....	11-2
		Counterrecoil Buffer Removal/Installation .....	11-3
		In-Battery Switch - Adjustment.....	11-3
		Procedure for Cycling CBSS.....	11-4
		7. 62-MM Coaxial Machine Gun Mount Removal/ Installation .....	11-4.1
		Ammunition Spent Brass Chute and Bag Removal/ Installation .....	11-5
		Recoil Mechanism Hand Pump and Fittings Removal/ Installation .....	11-6
		Buffer Bleed Line Removal/Installation.....	11-6.1

CHAPTER	11	ORGANIZATIONAL MAINTENANCE - ARMAMENT AND FIRE CONTROL - Continued	
Section	11-1	Primary Armament - Continued	
		Filling and Bleeding Gun Mount Hydraulic System.....	11-6.1
		Gun Mount Hydraulic System Leak Test .....	11-6.2
		Recoil Guard Cover and Screen Removal/Installation .....	11-7
		Recoil Mechanism Reservoir and Components Removal/Installation. ....	11-8
		Breech Scavenger Check Valve Removal/Installation.....	11-10.2
		Breech Scavenger Check Valve Disassembly/Assembly .....	11-10.4
		Gun-Launcher Wiring Harness and Breech Limit Switches Removal/Installation .....	11-13
		Gun-Launcher Firing Mechanism Removal/Installation .....	11-14
		Gun-Launcher Breech Drive Motor Removal/Installation .....	11-15
		Gun-Launcher Breech Drive Solenoid Removal/Installation.....	11-16
		Gun-Launcher Loading Tray Removal/Installation .....	11-16
		Gun-Launcher Loading Tray Disassembly/Assembly .....	11-17
		Gun-Launcher Loading Tray and Ejector Adjustment.....	11-20
		Gun-Launcher Loading Tray Guide and Ejector Cocking Bracket Removal/Installation.....	11-21
		Gun-Launcher Ammunition Detent and Trigger Lever .....	11-22
		Gun-Launcher Obturator Seal Removal/Installation .....	11-24.3
11-2.		Secondary Armament .....	11-25
		Grenade Launcher M176.....	11-25
11-3.		Sighting and Fire Control .....	11-28
		Purging Laser Range Finder Units (M551A1 Only) .....	11-28
		Synchronization of XM44 Series Periscope.....	11-33
		M37 Loader's Periscope Mount and Seal Removal/ Disassembly/Assembly/Installation .....	11-35
		Driver's M47/48 Periscope Mount and Seal Removal/ Installation .....	11-36
		Driver's Periscope Washer, Pump, and Reservoir Removal/Installation .....	11-38
		M119 or M127 Telescope Removal/Installation.....	11-39
		M149 or M165 Telescope Mount Removal/Installation.....	11-40
		Inspection of Telescope Mount Bracket Bolts .....	11-40
		M13A1C Elevation Quadrant Removal/Installation .....	11-40.1
		XM44 Series Periscope Body and Head Removal/installation .....	11-40.2
		Servicing XMI44 Series Emergency Periscope Battery .....	11-40.3
		XM44 Series Periscope Washer, Pump, Reservoir and Blade Removal/Installation .....	11-41
		XM44 Series Periscope Linkage Removal/Installation .....	11-42
CHAPTER	12	SPECIAL PURPOSE KITS	
Section	12-1.	General .....	12-1
	12-2.	Deleted	
	12-3.	Deleted	
	12-4.	Engine and Battery Winterization Kit .....	12-1
	12-5.	Less Missile System Kit .....	12-1
	12-6.	Mine Protective Kit .....	12-2
	12-7.	Deleted	

CHAPTER 13 DESCRIPTION, OPERATION AND MAINTENANCE OF  
7. 62MM MACHINE GUN M73E1

Section 13-1. Description and Data ..... 13-1  
13-2. Operating Instructions..... 13-2  
13-3. Maintenance Instructions..... 13-4  
13-4. Ammunition ..... 13-8  
13-5. Shipment and Limited Stowage and Demolition To Prevent  
Enemy Use ..... 13-8

APPENDIX I. REFERENCES ..... A-1

APPENDIX II. BASIC ISSUE ITEMS LIST

Section B-1. Introduction ..... B-1  
B-2. Basic Issue Items List ..... B-3  
B-3. Maintenance and Operating Supplies..... B-15

APPENDIX II. MAINTENANCE ALLOCATION CHART

Section C-1. Introduction ..... C-1  
C-2. Maintenance Assignment ..... C-3  
C-3. Tool and Test Equipment ..... C-24

INDEX..... INDEX-1

**CHAPTER 1  
INTRODUCTION**

**Section 1-1. SCOPE, SECURITY CLASSIFICATION,  
MAINTENANCE ALLOCATION, RECORDS, REPORTS, AND  
EQUIPMENT SERVICEABILITY CRITERIA**

**1-1. Scope**

This manual contains operating and organizational maintenance instructions for the Armored Reconnaissance/Airborne Assault Vehicle: Full Tracked, 152MM, M551. Other applicable publications are referenced in Appendix I.

**1-2. Shillelagh Missile Subsystem Security Classification.**

Commander's responsibility and classification data TB 9-380-101.

**1-2.1. Lubrication**

Refer to LO 9-2350-230-12 for crew/operator lubrication instructions.

**1-3. Maintenance Allocation**

The maintenance allocation chart (Appendix III) allocates maintenance responsibilities.

**1-5. Description**

The M551 (figures 1-1 and 1-2) is a light weight, full tracked, deisel powered armored reconnaissance/airborne assault vehicle. It is capable of amphibious operation and can be transported and air-dropped by heavy assault glider or cargo aircraft. Armament consists of a 152MM gun/launcher mounted to a 360-degree rotatable turret and capable of firing either conventional ammunition or guided missiles; a 7.82MM machine gun mounted coaxially with the gun/launcher; a cal. .50 machine gun mounted to the commander's power assist cupola, which is capable of 360-degree rotation; and eight fixed-mount grenade launchers, four on each side of the turret. M551 vehicles equipped with M81 gun/launcher employ a CO<sub>2</sub>

**1-4. Forms, Records, Reports, and Equipment Serviceability Criteria**

a. Forms and Records. TM 38-750.

b. Field Report of Accidents.

(1) Injury to personnel or damage to materiel.  
AR385-40.

(2) Ammunition accident or malfunction.  
AR 75-1.

c. Serviceability Criteria. TM 9-2350-230ESC.

d. Errors and Omissions. Report of errors, omissions, and recommendations for improving this publication by the individual user is encouraged. Reports should be submitted on DA Form 2028 (Recommended Changes to Publications) and forwarded directly to Commanding General, US Army Tank-Automotive Command, ATTN: AMSTA-MAPC, Warren, Michigan 48090

**Section 1-2. DESCRIPTION AND DATA**

bore and breech scavenging system to clear the gun/launcher of residue and/or gases resulting from firing. Later vehicles are equipped with the M81EI gun/launcher, which employs a compressed air closed-breech scavenging system for the same purpose.

**1-6. Tabulated Data**

a. General

Crew (1-commander, 1-driver,  
1-loader, 1-gunner..... 4  
Weight Classification ..... No. 20 (Tons)  
Weight, combat loaded ..... 33,460 lb  
Weight, curb (less fuel, crew,  
and basic issue items) ..... 28,525 lb  
Weight, total air drop rate ..... 35,00 lb max

Overall length ..... 248 in. (20ft 8 in.)  
 Overall width..... 110 in. (9 ft 2 in.)  
 Overall height  
 (over machine gun) ..... 116 in. (9 ft 8 in.)  
 Freeboard (to top of hull)  
 Static:  
     Front ..... -2-1/2 in.  
     Rear..... + 2-1/2 in.  
 Moving:  
     Front ..... 1/2 in.  
     Rear..... +1/2 in.  
 Ground clearance ..... 19 in.  
 Shipping cubic ..... 1831 cu ft  
b. Performance.

Maximum speed (fourth range) ..... 43 mph  
 Maximum speed (reverse) ..... 9 mph  
 Maximum grade (ascending  
 or descending) ..... 60%  
 Maximum trench crossing width ..... 7 ft  
 Maximum range.....373 miles  
 Vehicle obstacle ability ..... 33 in.  
 Minimum turning radius ..... Pivot  
c. Engine 6V53T.

Type ..... Diesel  
 Compression ratio ..... 17:1  
 Gross horsepower at 2800 rpm ..... 300  
 Fuel oil ..... Diesel: 40 cetane, Fed.  
     ..... VV- F- 800 or CITE

CAUTION: Use the following grades of fuel  
 oil at indicated temperatures:

Regular Grade0  
 (DF-2) (NATO F-54) ..... 20° to +115°F  
     ..... (-7°C to +46°C)  
 Winter Grade (DF-1) ..... 25° to +20°F  
     ..... (-32°C to 7°C)  
 Arctic Grade  
 (DF-A) (NATO F-56)..... 25° to 65°F  
     ..... (-32°C to 54°C)

NOTE. During certain emergency conditions,  
 JP-5 aircraft turbine engine fuel may be used in  
 lieu of diesel fuel.

Fuel tank capacity (usable)..... 158 gal  
 Fuel tank maximum  
 acceptance rate..... 50 gal per min. (avg.)  
 Fuel weight ..... 6.45 lb per gal  
 Lubricating oil system capacity:  
     Dry ..... 21 qt  
     Refill ..... approx. 18 qt

Cooling system:  
 Capacity:  
     Dry..... 44-1/2 qt  
     Refill .....32 qt  
 Antifreeze (-40°F. and above):  
 Mixture with water ..... 50%  
 Type:  
     6850-243-1992 ..... 1 gal container  
     6850-224-8730..... 5 gal container

Antifreeze  
 (Arctic type) ..... (-40° Fto-65°F):  
 Mixture ..... Full strength  
 Type, 6850-174-1806..... 55 gal drum  
 Inhibitor (Above 80°F)  
 Mixture ..... 22-1/2 oz. per vehicle  
 Type 6850-753-4967..... 6 oz. Can  
d. Transmission - XTG-250-1A.

Steer Control:  
 Land:  
     Pivot steer ..... First and both  
     ..... reverse ranges  
     Geared steer ..... Second, third, and  
     ..... fourth ranges

Water:  
     Pivot steer ..... All ranges except  
     ..... fourth range

Oil Capacity:  
     Dry .....56 qt  
     Refill .....44 qt  
 Brakes ..... Multiple wet plate,  
     ..... mechanical-applied  
e. Electrical System.

Nominal voltage ..... 24DC  
 Batteries .....4

f. Suspension.

Torsion bar ..... Independent type  
 Road wheels ..... 10 dual  
 Size ..... 28 in.  
 Track type ..... 102 steel, rubber bushed  
     ..... pin-link shoe  
 Width .....17-1/2 in.

g. Armament.

Gun-Launcher, 152MM:  
 Weight of gun-launcher .....10971b  
 Length..... 116in.  
 Recoil (conventional ammunition)..... 15 in.  
 Breech actuation ..... Electrical or manual  
     ..... separable sliding-rotating  
     ..... breech chamber

Breech chamber ..... Left-hand 200 buttress threads ..... 300 interruptions  
 Firing method ..... Electrical impulse only  
 Bore size ..... 152-mm (6 in.)  
 Tube rifling:  
     Length..... 95.65 in.  
     Depth of groove..... 0. 050 in.  
     Width of groove..... 0. 245/0. 253 in.  
     Width of land ..... 0. 1434 in.  
     Number of grooves..... 48  
     Twist ..... 1 turn in 41. 2 calibers  
 Elevation ..... 1.9 deg  
 Depression ..... -8 deg  
 Traverse ..... 360 deg right or left  
 Missile weight ..... 58 lb ea  
 Conventional ammunition weight..... 48 lb ea

Machine gun, 7-62-mm, M73:  
 Weight ..... 29.31 lb  
 Length ..... 38 in.  
 Rate of fire..... 450-500 rpm approx  
 Feed ..... link belt

Machine gun, 7. 62-mm, M219:  
 Refer to paragraph 13-3

Machine gun, Cal 50, M2, HB:  
 Weight 84 lb  
 Weight of barrel..... 28 lb  
 Length, overall..... 65. 13 in.  
 Cyclic rate of fire ..... 450-500 rpm  
 Maximum effective range ..... 2000 yd

Grenade launcher ..... Fixed type, 8 tubes  
g.1 Compressor Unit.

Type .....reciprocating  
 Operating speed..... 3750 rpm  
 Operating pressure..... 3000 psi  
 Lubricant (9150-753-4667) capacity:  
     Walter Kidde  
         (4310-460-2184)..... 4/5 pt  
     Bogue  
         (4310-181-8895)..... 4/5 pt  
     Stewart Warner  
         (4310-196-1617) . ..... 1 pt

h. Sighting and Fire Control Instruments.

Azimuth indicator (10954720):  
 Dial graduations:  
     (100-mil) ..... 0 to 3200 mils  
         ..... right and left, numbered  
         ..... every 200 mils  
     (1-mil) ..... 0 to 100 mils,  
         ..... numbered every 5 mils  
 Weight ..... 24 lb  
 Height ..... 12 in.  
 Diameter. .... 7 in.

Gunner's aid dial:  
     ..... 0 to 50 mils right and  
     ..... left numbered every 5 mils

Elevation Quadrant, M13A1C:  
 Weight . .... 2. 06 lb

Individual weapons night vision sight, PVS2:  
 Weight. .... 12. 7 lb  
 Optical characteristics:  
     Magnification ..... 4.0 power  
     Field of view ..... 185 mils  
     Eyepiece focus ..... +4 to 4 diopters  
     Objective lens focus 4 meters to infinity

Periscope, XM44 Series (gunner's):  
 Weight ..... 134-1/2 lb  
 Optical characteristics:  
     High power system:  
         Magnification ..... 9X  
         Field of view ..... 6 deg  
     Unity power system:  
         Field of view ..... 22 deg horizontal  
                 ..... 8 deg vertical  
         Line of sight travel ..... 22 deg elevation  
                 ..... 18 deg depression

Temperature range  
 (operable) ..... 65°F to +160°F

Periscope, M47, M48 (driver's):  
 Weight:  
     M47 (3)..... 29. 1 lb  
     M48 (infrared) ..... 16.0 lb  
     Temperature range  
     (operable)..... 65°F to +125°F

Periscope, M37 (loader's):  
 Weight ..... 14.5 lb  
 Optical characteristics:  
     Field of view  
     (6 in. eye distance) ..... 50 deg horizontal  
     ..... 14 deg vertical  
     Line-of-sight ..... one deg physically  
     ..... two deg optically

Telescope, M119 (gunner's):  
 Length, telescope. .... 41 in.  
 Length, telescope in mount M149 . .... 48 in.  
 Weight, telescope ..... 37 lb  
 Weight, telescope and mount ..... 57 lb  
 Operable temperature  
     range ..... 65° to +1250 F  
 Optical characteristics:  
     Magnification ..... 8X  
     Field of view ..... 8 deg  
     Reticle pattern,  
         conventional ammunition ..... ballistic



## Telescope, M127 (gunner's):

Length, telescope..... 41-1/4 in.  
 Magnification ..... 8X or 12X  
 Field of view (8X) ..... 8 deg  
 (12X) ..... 5.333deg

## Mount, Telescope, M149:

Length ..... 28 in.  
 Width ..... 10 in.  
 Height ..... 12 in.  
 Weight ..... 20 lb

i. Missile Subsystem Units.

Optical transmitter ..... 34.1 lb  
 Signal data converter..... 53.6 lb  
 Modulator ..... 42.7 lb  
 Power supply ..... 45.3 lb  
 Test checkout panel ..... 12.4 lb  
 Rate sensing unit. .... 9.9 lb  
 Optical tracker ..... 16.8 lb

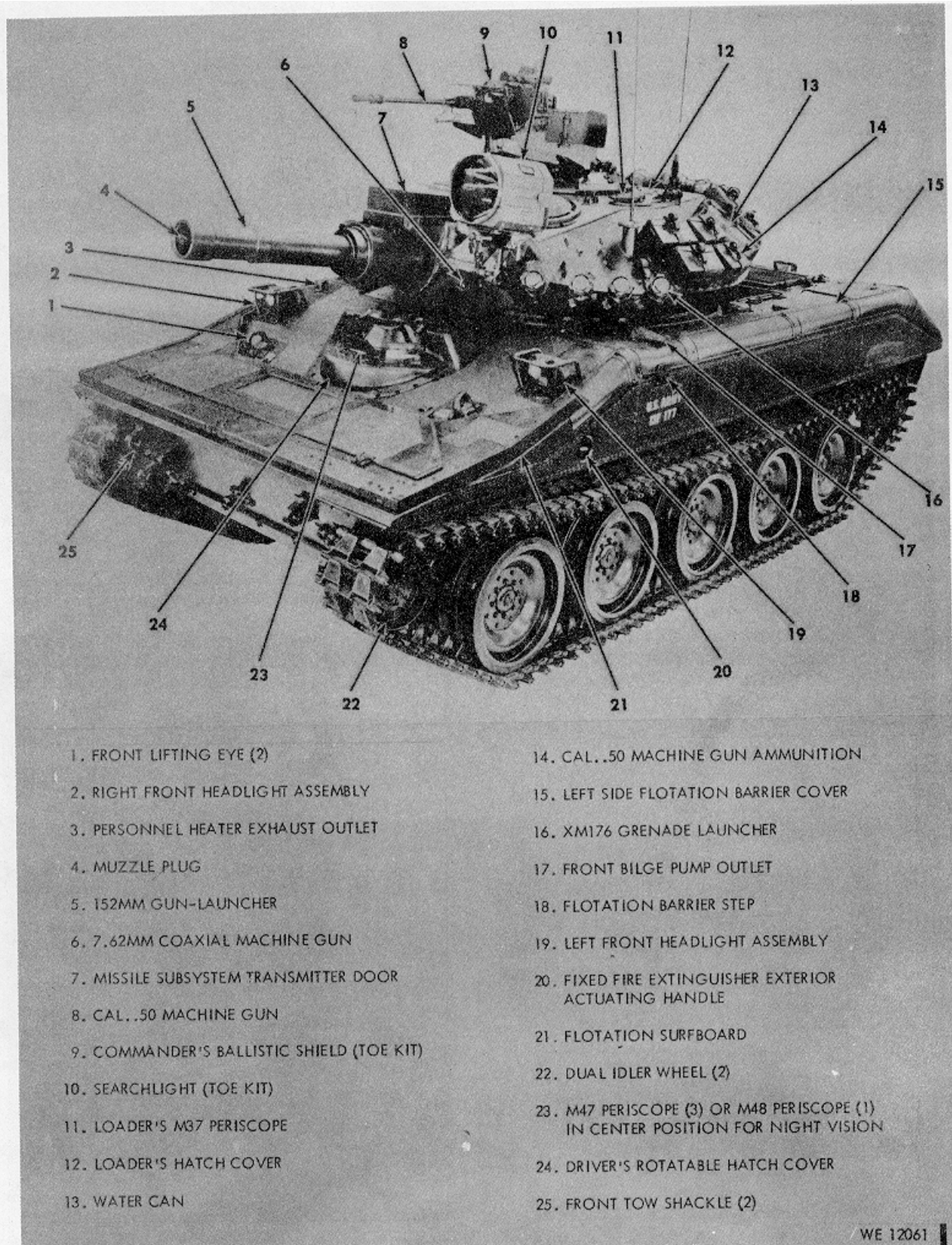

Figure 1-1. Armored reconnaissance/airborne assault vehicle: full tracked, 152MM, M551-left front view

1-4.2/(1-4.1 blank)

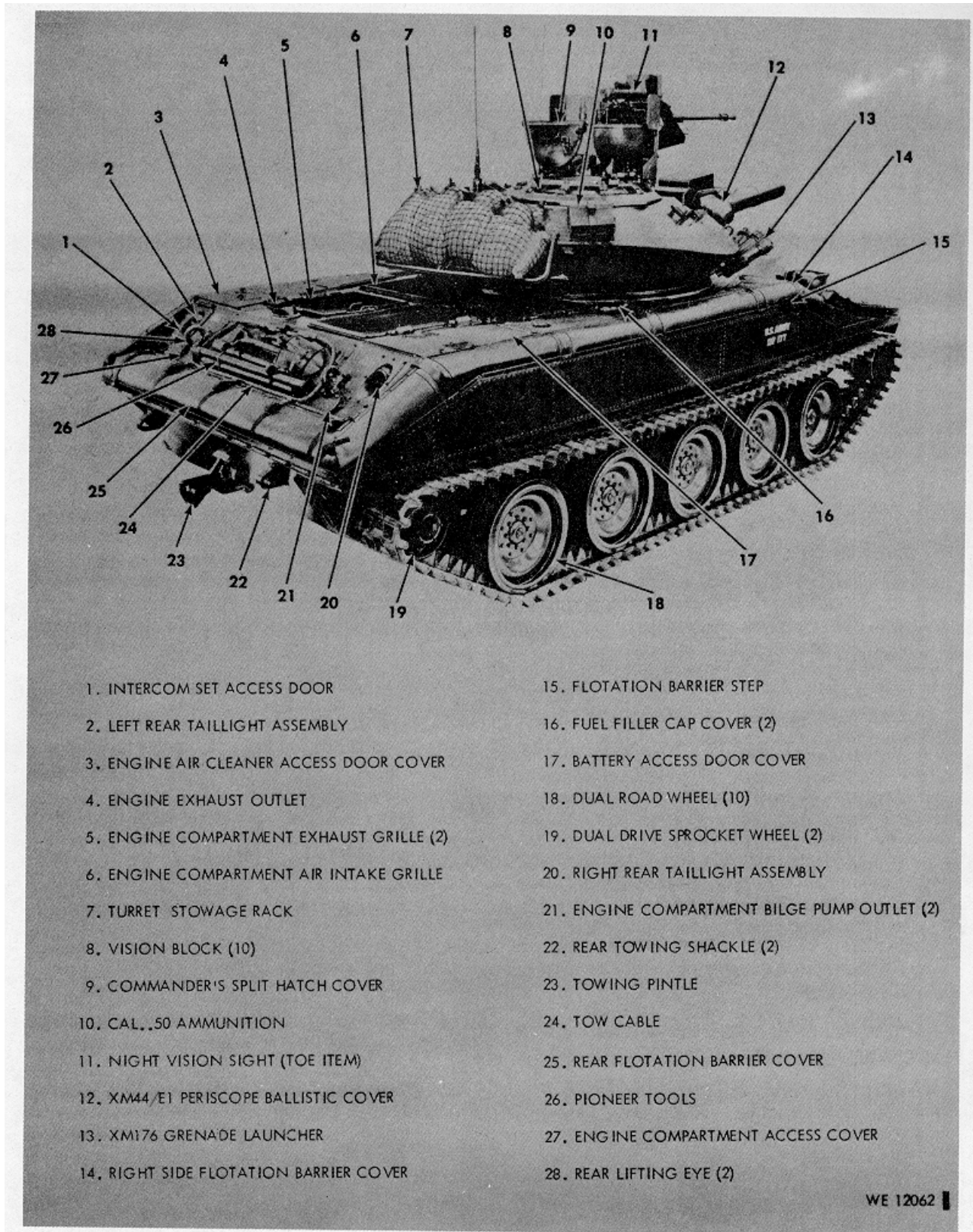

Figure 1-2. Armored reconnaissance/airborne assault vehicle: full tracked, 152mm, M551- right rear view

## Section 1-3. SAFETY PRECAUTIONS

## 1-7. Vehicle

**CAUTION:** To enter driver's compartment by way of open space between air compressor and rear air bottle, manually traverse turret so gun launcher is positioned over rear deck. This method of entry prevents damage to stowed ammo in racks under gun/launcher.

a. Be certain water steer lever is in LAND position when driving vehicle on land to prevent damage to transmission and possible loss of vehicle control.

b. When raising or lowering driver's seat, keep body weight on seat.

c. Until driver becomes familiar with vehicle, every precaution must be taken not to overdrive or allow loss of vehicle control.

d. When driving vehicle, make certain driver's rotatable hatch cover is secured in the open or closed position.

e. Do not leave vehicle with engine running.

f. If track is thrown while operating vehicle, do not apply brake. Allow vehicle to coast to stop.

g. Make certain that vehicle is combat loaded with equipment correctly stowed and secured when swimming vehicle.

h. Attach tow cable to front or rear tow shackles when swimming vehicle to facilitate towing in case of an emergency.

i. During vehicle swimming, if a solid stream of water continues to emit from bilge pump outlets, beach vehicle immediately.

j. Do not allow personnel between vehicles when slave starting.

k. The M8A3 air filter unit will not protect user against carbon monoxide.

l. With standard track, the vehicle is difficult to control on snow and ice. Use of arctic track will improve vehicle control.

m. Inspection for spilled fuel should be made before and after operation and at halt in order to prevent fires.

## 1-8. Turret and Cupola

a. Make certain all personnel are clear of hull when traversing turret and that area is clear of obstacles.

b. When traversing cupola, loader's hatch cover must be in fully opened or closed position and turret area clear.

## 1-9. Sighting and Fire Control

a. When XM44 Series periscope is not in use, turn periscope ON/OFF switch to "OFF". Place filter selector lever in "DARK"(XM44) or "OFF" (XM44E Series) position to prevent damage to internal components close ballistic cover.

b. When operating night vision sight for cal. .50 machine gun, keep eyeshield in contact with face to prevent emission of visible glow.

c. Do not look directly into searchlight beams. Serious eye damage can result.

d. Prior to installing new battery for XM44 Series periscope, replace shipping plugs with vented caps.

e. Hazardous radiation conditions exist when plastic dial window of azimuth indicator is broken or removed. DO NOT TOUCH DIAL POINTERS.

## 1-10. Armament

a. Reject all HEAT warhead missiles that have dented nose cones.

b. Do not handle or move duds, except to remove from weapon in a tactical situation. Under no circumstances will a HEAT-T-MP or HE round be fired that has been allowed to remain in a hot gun-launcher more than 5 minutes.

c. Handle ammunition with care. Electric primers are sensitive to shock and high temperature.

d. Use only correct lots of ammunition and handle with care. Avoid striking fuze or primer.

e. When operating winterization kit coolant heater, turret must be positioned so that neither grenade launcher mount is over the heater exhaust outlet.

f. Do not smoke in crew compartment of vehicle.

g. The check valve assembly in closed breech scavenging system should be cleaned at intervals not to exceed 100 rounds.

**CAUTION:** Avoid damage to air cylinders, which are under very high pressure.

h. Inspect detent hole and replace preformed packing of gun tube-to-detent housing seal every 40 rounds.

i. If vehicle is not equipped with closed breech scavenging system, missile firing causes a high concentration of carbon monoxide in the crew compartment. Therefore, crew members should not be exposed to more than ten missile firings per day. Turret blower must be on during missile firing to remove toxic gases.

j. The driver's hatch must be closed for all main gun firings. All crew members should be inside the vehicle to prevent injury from muzzle blast of a conventional round or, in the case of a missile firing in training with live warhead, to prevent possible fragment spray from early ground impacts.

k. Flarebacks have occurred from firing missiles when vehicle is not equipped with closed breech scavenging system. To reduce the hazard, the nylon and neoprene bags of a conventional round which is to be fired following a missile firing should not be removed until it is evident that a flareback did not occur.

l. Missiles should not be fired over friendly troops in training due to the hazard from early ground impacts.

m. The closed breech scavenging system has been developed to remove smoldering residue from the gun-launcher. However, when the vehicle is so equipped, these precautions should be followed:

- (1) When maximum firing rate is not required, thoroughly inspect the rear

part of the tube, especially around the forcing cone and the breech cavity. Smoldering residue, no matter how small, must be removed before the next round is loaded.

- (2) When near maximum firing rate is required, inspect rear part of tube only. If smoldering residue is observed, remove it and also inspect and clear any smoldering residue from breech cavity before loading the next round.
- (3) When maximum firing rate is essential, inspection for residue is not required.

n. When live round is chambered and breech closed, never turn blasting machine handle unless firing is intended. Blasting machine provides direct circuit emergency fire capability to 152-mm gun/launcher.

o. Gun-launcher will fire despite loss of safe to-fire and ready light indicators.

#### 1-11. Grenades and Launchers

**NOTE.** Refer to TM 3-1330-203-10 for further safety precautions.

a. Since the vehicle is within range of fragments from the WP grenade M34, the crew should be inside the vehicle with the hatches secured in the closed position during firing.

b. Check condition of grenades and launchers as soon as possible after vehicle is subjected to attacking projectiles or shell fragments to make certain white phosphorous is not leaking onto the hull from damaged grenade(s).

## Section 1-4. VEHICLE PERFORMANCE CHARACTERISTICS AND LIMITATIONS

Every type of Army equipment has certain characteristics that are different from similar equipment. Some of these characteristics are "signatures" that allow identification, while others merely impose operational limitations and/or operational guidance. Familiarity through practice and experience will result in controlling these characteristics and avoid unnecessary problems. Some of the AR/ AAV M551 characteristics and conditions under which they occur or are more pronounced have been included herein for training and operational guidance.

### 1-12. Automotive

a Under certain conditions, noise from the engine turbocharger and the "rooster tail" of exhaust smoke during vehicle acceleration will be more noticeable. By comparison, the M551 total noise and exhaust smoke, because of its smaller engine is much less than larger track laying vehicles. The possibility of these conditions occurring are more probable when:

- (1) Operating the vehicle before the engine has warmed sufficiently.
- (2) Engine lacks power due to restricted air induction system, leakage in the air induction system affecting the air/fuel ratio, or other mechanical malfunction.
- (3) Improper driving techniques such as lugging the engine, fanning the accelerator pedal unnecessarily and/or applying instant thrust of throttle pedal (floor boarding).
- (4) Racing a free engine, throttle fanning, and operating in improper gear range will result in more noticeable turbocharger whine.

b. During operation under extremely dusty conditions (zero visibility), the engine air cleaner may clog within one hour and should be frequently checked and cleaned or replaced as necessary. Under such extreme conditions, it

may be necessary to check the air restriction indicator at 30 minute intervals. If indicator is red, clean filter element. (Due to varying conditions resulting from geographical locations and other factors, commanders must establish the frequency of air cleaner service to accommodate their peculiar environmental condition.)

c. Operation of the vehicle in water necessitates observation of all precautions normally required in the operation of waterborne vessels.

Vehicle speed in still water is approximately 3.8 MPH and maneuverability and control are good. In moving water where the water speed approaches vehicle maximum speed, maneuverability and control are substantially affected. Water operation requires special training as outlined in TM 21-306, Manual for the Tracked Combat Vehicle Driver.

d. On early production vehicles (under serial number 140), the main gun, coaxial machine gun, and grenade launchers should not be fired with the swimming barrier erected due to the possibility of damage to the barrier. In later production, a quick release mechanism for the whole forward surfboard/barrier system is provided which, when released, allows firing of the main gun or coaxial machine gun within a 90 degree sector to the direct front.

e. When operating in jungle or heavy underbrush, vegetation can clog the air intake grilles and the radiator resulting in overheating and engine damage. Specific attention to cleaning at the halt and after daily operation will minimize the possibility of damage from overheating. (If sudden overheating under combat conditions is experienced, use of a lower gear range or running engine for a few moments at idle speed may correct the condition.)

### 1-13. Missile

a. Temperature changes may cause misalignment of the tracker. When temperature changes in excess of 30°F occur, the tracker should be checked and re-aligned as necessary.

b. Missile must not be fired when vehicle is in motion because it cannot be controlled.

**1-14. 152MM Conventional Ammunition**

a. If smoldering residue is observed in the gun-launcher, the following actions are recommended:

- (1) Check closed breech scavenging system for proper functioning.
- (2) Examine basic load of ammunition for moisture absorption (softness) or other contamination of the combustible cartridge case. Turn in soft or contaminated rounds.
- (3) Carefully inspect breech area for smoldering residue after subsequent firings. If smoldering residue recurs, turn in basic load for further detailed inspection.

b. The best estimate of emergency zero for telescope M19 is +5.0 mils elevation and +2.0 mils deflection.

c. Sensing at ranges less than 1000 meters is difficult due to firing shock, vehicle dis

placement, and obscurity caused by smoke. Assistance from a companion vehicle or other sources is recommended.

d. Cartridge, TP-T, XM411E3 is not ballistically matched with cartridge, HEAT-MP-T, XM409E5 and therefore should not be used to zero the weapon for firing cartridge XM409E5.

**1-15. Armament**

Starting with full bottles of compressed air, and with air compressor operating, there is enough compressed air for 22 rounds when firing at the maximum rate.

**1-16. Night Fighting**

Tracers from cal. .50 machine gun and main gun firing temporarily saturate gunner's periscope XM44, resulting in loss of vision.

**1-17. Air Drop System**

The air drop system (35,000 lb) for this vehicle has not completed service tests and is not available for use. The current vehicle configuration has not been air drop tested.

CHAPTER 2

OPERATING INSTRUCTIONS

Section 2-1. SERVICE UPON RECEIPT OF MATERIEL

2-1. Deprocessing Vehicle and Break-In Services

maintenance personnel are designated in the following tables and illustrations.

a. Services upon receipt of materiel to be performed by the crew and organizational

b. Read the DD Form 1397 tag and follow all precautions checked thereon.

TABLE 2-1. DEPROCESSING VEHICLE

STEP	PROCEDURE	FIG/ITEM
	<p><b>WARNING:</b> <u>Lift vehicle with lifting eyes on top of hull only. If necessary unfasten shipping cover at each end of vehicle and roll back until lifting eyes are exposed. Do not use tong lugs for lifting vehicle.</u></p>	
1	Remove vehicle closure kit.	2-1
2	Remove Basic Issue Items saddle.	2-2
3	Remove ventilation screen assemblies from access openings on hull bottom.	
4	Drain fuel and inspect filters (table 2-1. 1).	
5	Install plug assemblies (plug, preformed packing, screw and plate, located in driver's compartment) in hull access openings.	5-7
5.1	Remove preservative material from track adjuster piston and adjust track before operating vehicle.	5-4
6	Install tow shackles (located in driver's compartment) on tow lugs.	2-15
7	Remove cap or tape sealing engine exhaust outlet opening.	1-2/4
8	Remove plastic caps and/or tape from all openings leading to the interior of the engine, including oil level indicator rod cap, shroud opening, and oil filler caps.	5-2/A
9	Add electrolyte to batteries. Check that battery connections are tight, and that polarity is correct as shown in figure 9-97.	5-3/D 9-97
	<p><b>CAUTION:</b> <u>Do not start engine or operate accessories with auxiliary power until batteries are properly connected and electrolyte added.</u></p>	
10	Remove cap or tape sealing turbocharger air Inlet.	5-2/A



TABLE 2-1. DEPROCESSING VEHICLE - CONTINUED

STEP	PROCEDURE	FIG/ITEM
11	Hold turbocharger fan stationary with 1/2 inch socket wrench on fan hub nut. Start engine (table 2-3) and idle at 1500 RPM for 2 minutes. Stop engine, then remove socket wrench. (This step is necessary to assure proper lubrication of turbocharger fan bearing, if vehicle has not been operated for several months).	
12	Install turbocharger air inlet hose and clamps (table 9-1).	
13	Disassemble, clean, lubricate, and assemble cal.. 50 machine gun.	5-14
14	Install retracting slide assembly.	2-3
15	Check and adjust headspace and timing (tables 3-7 and 3-8).	
16	Install flash hider and carrier assembly. <b>CAUTION:</b> <u>Position carrier assembly in the 5 or 7 o'clock position on barrel to prevent damage antenna when cupola is traversed.</u>	3-10, 3-13
17	Install cal.. 50 machine gun spent brass ejection chute.	3-14
18	Install pintle support, cradle and pintle assembly, cal.. 50 machine gun, and cupola traverse mechanism exterior wiring harness and switch assembly.	2-4
19	Install turret stowage rack.	1-2/7
20	Remove protective materials from gun launcher, and traversing and elevating servomotor fan outlets. <b>CAUTION:</b> <u>Thoroughly remove all preservative grease from interior of gun tube and breech mechanism. Lubricate according to Table 5-8.1.</u>	5-10. 2
21	If vehicle is received with gun/launcher out of battery: a. Wipe recoil sleeve with clean dry cloth to remove dirt or dust. b. Inspect sleeve for evidence of rust and/or pitting. If rusted or pitted, notify support maintenance. c. Wipe sleeve with clean cloth saturated with hydraulic oil MIL-H-6083. d. Close pressure bleed valve and use hand pump to return gun to battery. <b>CAUTION:</b> <u>Keep hands and arms clear when pressurizing recoil mechanism. Return to battery (:an be sudden and without notice.</u>	3-2

TABLE 2-1. DEPROCESSING VEHICLE CONTINUED

STEP	PROCEDURE	FIG/ITEM
22	Recoil mechanism:	
	a. Check oil level in recoil mechanism with gun/launcher elevated to 265 mils.	3-2
	b. Pressurize recoil mechanism with hand pump until indicator rod is in safe range.	3-2
23	Insure that recoil mechanism is exercised as prescribed in TB 9-1000-234-35. (At time of deprocessing, recoil mechanism should be exercised 20-25 times).	
24	Operate and trim turret electric drive system Table 10-3.	
25	Air compressor:	
	a. Check oil level in air compressor.	
	b. Turn air compressor on and charge cylinders.	
	c. Check for leaks in closed breech scavenging system hoses and connections (use soap solution to check suspected areas).	
	d. Manually activate CBSS and check functional operation.	3-2. 3, 3-2. 4
	e. Operate CBSS electrically:	
	(1) Turn turret power switch "ON" and turret selector Switch to "CONV".	3-2. 3
	(2) Open CBSS air shut off valve.	3-2. 4
	(3) Remove one mounting screw and loosen other screw of in-battery switch bracket and swing up out of contact with actuator screw (see fig. 11-2). (M81E1 Gun Launcher).	
	<b>NOTE.</b> <u>Do not disturb the setting of switch attachment to bracket</u>	
	(4) To cycle CBSS, depress plunger of in-battery switch.	
	<b>WARNING:</b> <u>When 1. 7-second surge of air is completed the breech chamber opens automatically. All personnel must make certain to stand clear to prevent injury</u>	
	(5) After completion of CBSS cycling SHUT OFF turret power, return in-battery switch bracket to original position and replace and tighten mounting screws.	
	Check firing circuit using linear electromechanical actuator 4933-435-7736.	4-4
26		

TABLE 2-1. DEPROCESSING VEHICLE CONTINUED

STEP	PROCEDURE	FIG/ITEM
27	Missile guidance system and fire control deprocessing should be accomplished in accordance with separate instructions issued by appropriate agency.	
	NOTE. For inspection and service of missiles, refer to table 7-2	
28	Remove VCI bore tube from barrel of 7. 62MM machine gun and clean barrel with clean dry patches.	
29	Disassemble, clean, lubricate, and assemble 7. 62MM machine gun. Inspect for missing parts and proper assembly.	5-11, 5-12 LO 9-2350-230-12
30	Install flash hider on 7. 62MM machine gun.	5-13
31	Install 7. 62MM machine gun in mount and connect solenoid lead.	3-7
32	Install spent brass ejection chute extension.	3-7
33	Remove protective lubricants and coverings from sighting and fire control equipment.	
34	Check air drop knobs (table 6-1, items 12 and 18).	
35	Perform all "before operation" PM checks and services table 4-1.	
36	Perform the following PM checks and services table 8-17: Sequence numbers: 7. 1, 11, 12, 13; 16 through 27; 29, 33, 35; 39 through 43; 45 through 48; 52, 59.	
37	Perform vehicle break-in services table 2-2.	

**NOTE. VEHICLE MAY BE DRIVEN A SHORT DISTANCE WITH COVER ON. REMOVE FRONT AND REAR TIE-DOWN ROPES, UNZIP COVER AND SLIDE ON FRAME TOWARD CENTER OF VEHICLE.**

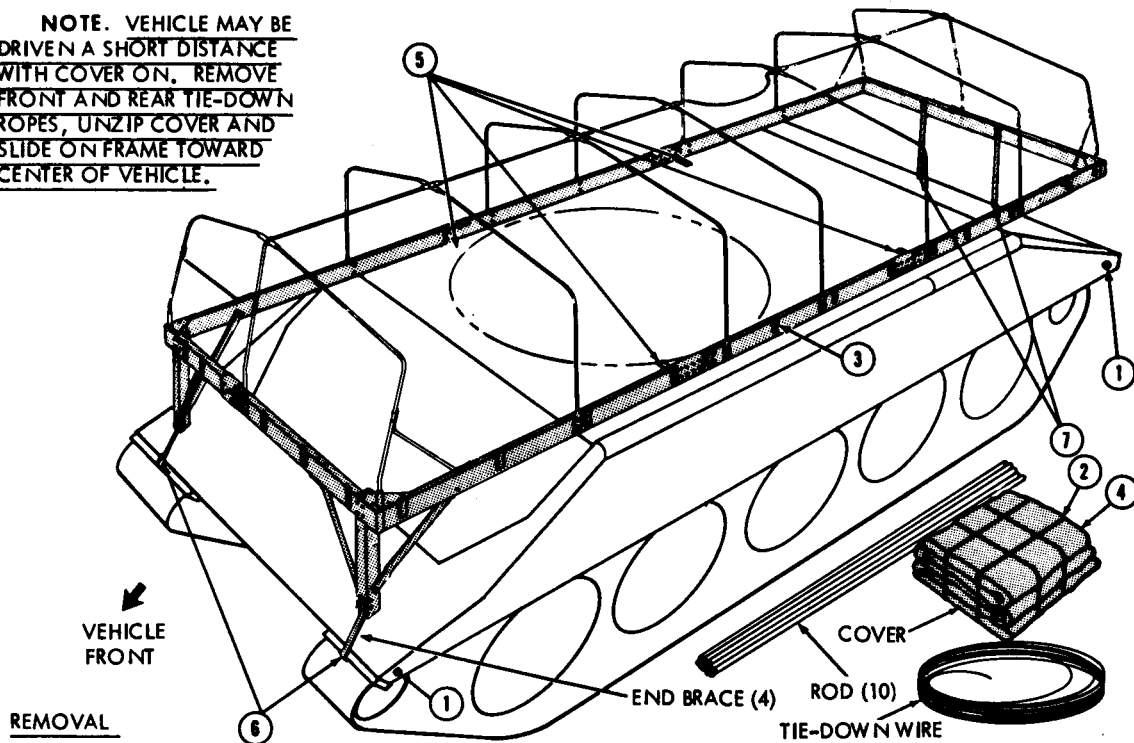

#### REMOVAL

1. LOOSEN 4 SCREWS (2 ON EACH SIDE OF HULL) AND REMOVE TIE-DOWN WIRE SECURING COVER TO HULL.
2. REMOVE ROPES (FRONT AND REAR) SECURING COVER TO TOW LUGS.
3. RELEASE (36) FASTENERS SECURING RODS IN COVER TO FRAME AND REMOVE RODS.
4. REMOVE COVER, FOLD, AND SECURE WITH ROPES REMOVED IN STEP 2.
5. REMOVE 4 SCREWS SECURING FRAME TO TOP OF HULL.
6. REMOVE 4 SCREWS SECURING FRAME END BRACES TO FRONT FENDER PLATES.
7. REMOVE 2 SCREWS SECURING FRAME END BRACES TO ENGINE COMPARTMENT ACCESS COVER.
8. DISASSEMBLE FRAME IN SECTIONS IF HOIST IS NOT AVAILABLE AND REMOVE FROM VEHICLE.
9. INSTALL 4 SCREWS REMOVED IN STEP 5.
10. INSTALL 6 SCREWS (BAGGED AND TAGGED IN DRIVER'S COMPARTMENT) 4 IN FRONT FENDER PLATES AND 2 IN ENGINE COMPARTMENT ACCESS COVER.
11. DISASSEMBLE FRAME AND STORE WITH COVER, TIE-DOWN WIRE AND 6 SCREWS REMOVED IN STEPS 6 AND 7.
12. RETURN COMPLETE CLOSURE KIT TO LOCAL SUPPLY ELEMENT WHEN VEHICLE IS GOING INTO FIELD USE.
13. REQUISITION AND REINSTALL CLOSURE IF VEHICLE IS TO BE HELD IN OPEN STORAGE FOR PROLONGED PERIODS.

#### INSTALLATION

REVERSE REMOVAL PROCEDURE.

WE 66568

Figure 2-1. Removal/installation - vehicle closure kit

(2-2.4 Blank) 2-2.3

TABLE 2-1.1. FUEL FILTER INSPECTION

STEP	PROCEDURE	REFERENCE
1	Completely drain fuel tanks to remove preservative, residual fuel, and accumulated condensation.	Table 5-4
2	Drain primary and secondary fuel filters	Fig. 5-2
3	Remove primary fuel filter element and inspect for grease-like substance. CAUTION: <u>Avoid damaging shell gasket.</u>	Fig. 9-17
4	a. If no evidence of contamination is found, reinstall element b. If grease-like substance is present, clean filter shell with fuel or solvent and install new filter - 2940-745-7730.	Fig. 9-17
5	Close all fuel drains and fill tanks with specified fuel	Par. 1-6c

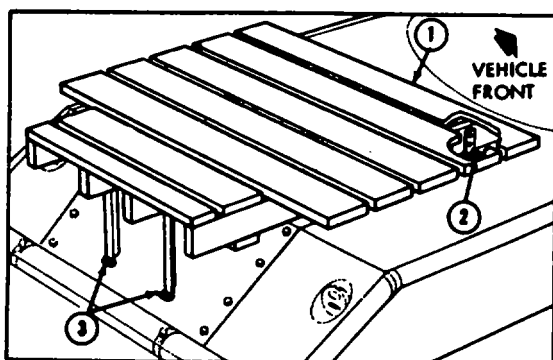
**REMOVAL PROCEDURE**

1. REMOVE BASIC ISSUE ITEM BOXES SECURED TO SHIPPING SADDLE.
2. REMOVE TWO 2 SCREWS SECLUING SADDLE TO AR INTAKE GRILLE.
3. REMOVE TWO 2 SCREWS SECURING SADDLE TO ILOCKS ON ENGINE COMPARTMENT ACCESS COVER.
4. REMOVE SADDLE AND REINSTALL SCREWS ON ACCESS COVER.
5. SECURE AIR INTAKE GRILLE (STEP 2) WITH 2 SCREWS LOCATED IN DRIVER,S COMPARTMENT.
6. SECURE SCREWS REMOVED IN STEP 2 TO SADDLE AND STORE.
7. CHECK AND STOW SPARE PARTS AND EQUIPMENT IN ACCORDANCE WITH BASIC ISSUE ITEMS UST (A ENDIX 11).

Figure 2-2. (Superseded) Removal - basic issue (O.E.M.) items

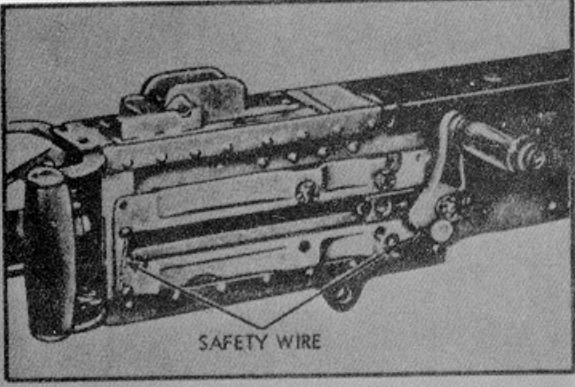
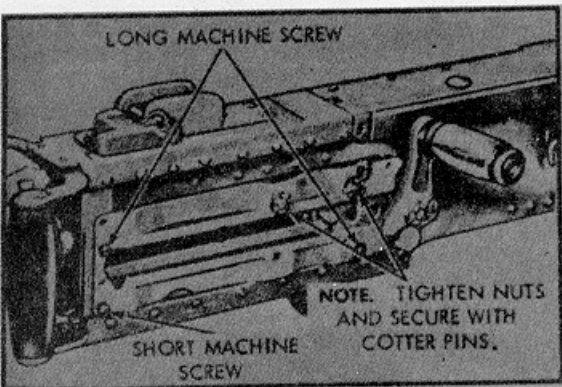
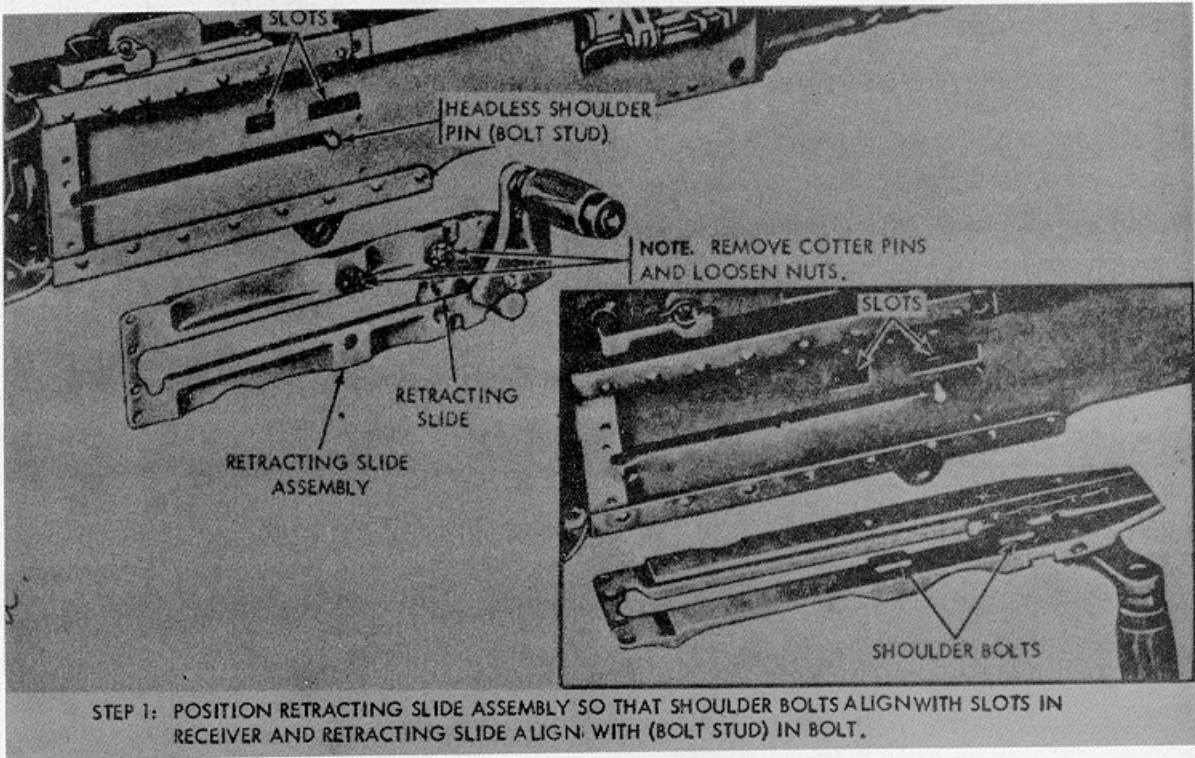

WE 10934

Figure 2-3. Installation of retracting slide assembly on cal. .50 machine gun, M2, HB, flex. type

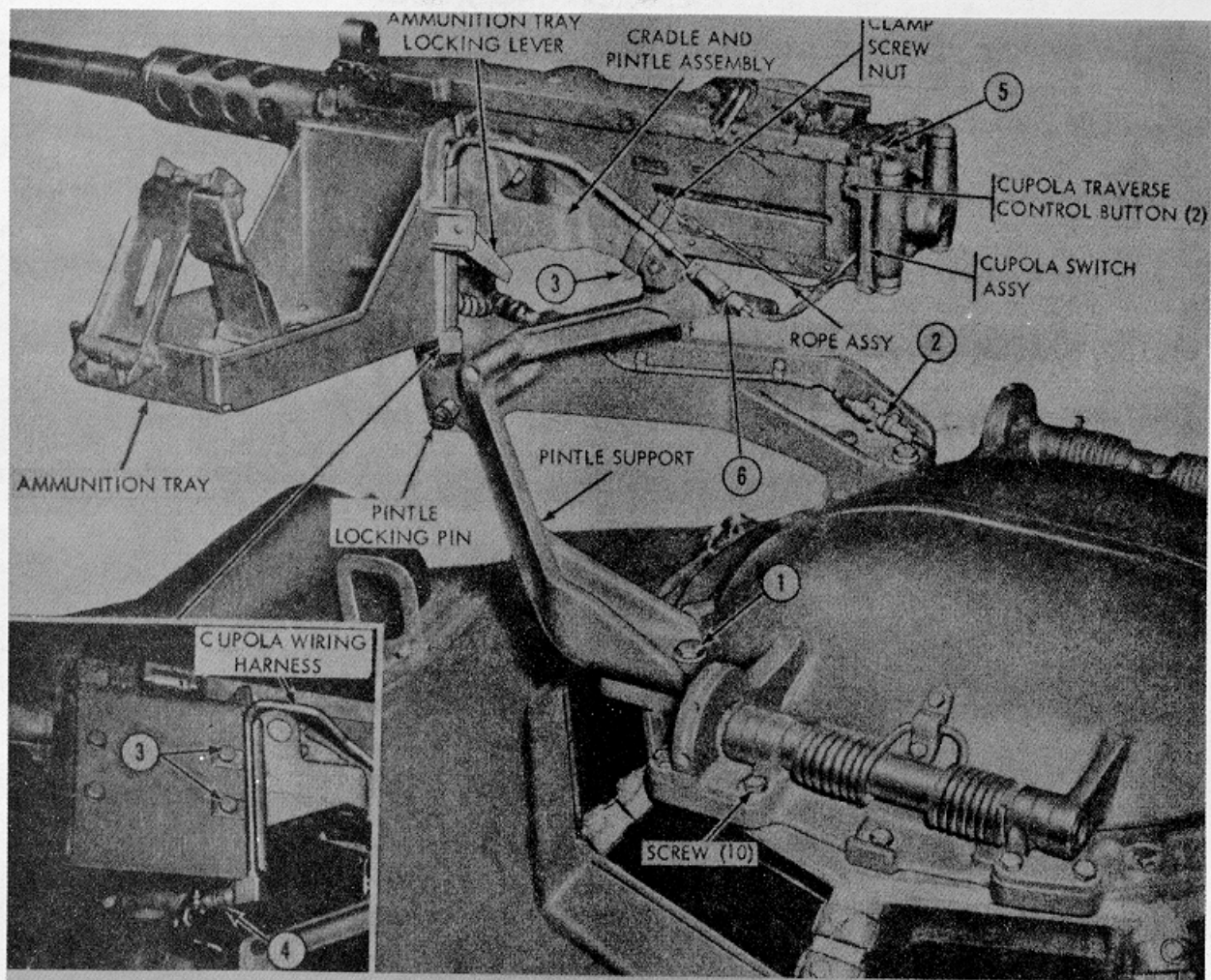

STEP	PROCEDURE
1	INSTALL 4 SCREWS AND FLAT WASHERS AND SECURE MACHINE GUN PINTLE SUPPORT TO CUPOLA.
2	CONNECT PINTLE SUPPORT WIRING HARNESS TO CUPOLA HARNESS.
3	SECURE WIRING HARNESS TO CRADLE AND PINTLE ASSEMBLY AND INSTALL IN PINTLE SUPPORT.
4	CONNECT WIRING HARNESS.
5	INSTALL CAL. .50 MACHINE GUN (FIG. 3-14) AND SECURE CUPOLA TRAVERSE MECHANISM SWITCH ASSEMBLY WITH 4 SCREWS.
6	CONNECT CUPOLA TRAVERSE MECHANISM SWITCH ASSEMBLY TO WIRING HARNESS.

WE 10911

Figure 2-4. Installation of pintle support, cradle and pintle assembly and cupola traverse mechanism switch assembly

TABLE 2-2. BREAK-IN SERVICES

STEP	PROCEDURE	REFERENCE
1	<p style="text-align: center;"><b>DRIVE BELTS</b></p> <p>Check tension of generator, fan, and coolant pump drive belts Check vehicle for damage and loose attaching hardware.</p> <p><b>NOTE.</b> <u>If vehicle is scheduled for storage in excess of 90 days, release tension on all drive belts, notify organizational maintenance personnel.</u></p>	5-2/A
2	<p style="text-align: center;"><b>LUBRICATION</b></p> <p>Check fuel and coolant levels Perform a complete suspension lubrication (LO 9-2350-230-12), Appendix IV.</p>	5-2/A
3	<p>Check DD Form 1397 tag for engine and transmission oil viscosity If tag states oil is of proper viscosity for local operation, check the level (LO 9-2350-230-12) but do not change the mil. OE10 may be added to PE1 or OE30 to PE2 to maintain proper level in engine and transmission until first scheduled change.</p> <p><b>NOTE.</b> <u>Preservative engine oils PE1 and PE2 are identical to engine oils OE10 and OE30, except that PE1 and AE2 have a preservative additive. PE1 and PE2 will be used in the same manner as the regularly used engine oil OE10 or OE30.</u></p>	5-2/A
4	<p style="text-align: center;"><b>ROAD TEST</b></p> <p>Drive 5 to 10 miles.</p> <p><b>NOTE.</b> <u>If a vehicle was driven to the using organization, consider the mileage traveled as break-in mileage.</u></p>	
5	<p>Observe all instruments and gages during road test</p> <p><b>CAUTION:</b> <u>Do not engage in excessive speeds, accelerate rapidly, or in any way load the engine or power train to capacity during the break-in period.</u></p>	2-9
6	<p>Stop vehicle every mile and check for overheated hubs on road wheels and idler wheels, and for lubricant leaks.</p> <p style="text-align: center;"><b>AFTER ROAD TEST</b></p>	
7	<p>Upon completion of road test, perform after-operation preventive-maintenance checks and services (table 4-1, steps 75 through 100) and notify organizational maintenance to retorque air cleaner hose clamps.</p> <p style="text-align: center;"><b>CORRECTION OF EQUIPMENT FAULTS</b></p>	
8	<p>Correct and report all equipment faults.</p>	



**Section 2-2. VEHICLE OPERATION**

**2.2. Operation Under Normal Conditions**

The following tables and illustrations provide vehicle operating instructions.

**NOTE:** Before operation the crew should be familiarized with the location and operation of all controls and instruments (figs. 2-5 through 2-15).

- a. Special Driving Instruction. TM21-306.
- b. Cold Weather Starting. Figure 2-14, table 2-4., 1, and TM 9-207. At -10' F and below, four batteries are required. If vehicle has only two, notify organizational maintenance.
- c. Extreme Hot and Cold Weather Operation. Continuously observe engine, transmission, and coolant temperature warning lights (fig. 2-9).

**2.3. Operation Under Unusual Conditions**

*TABLE 2-3. STARTING, DRIVING, AND STOPPING VEHICLE*

STEP	PROCEDURE	REFERENCE
<b>PRE-STARTING INSTRUCTIONS</b>		
<p><b>CAUTION:</b> <u>To enter driver's compartment by way of open space between air compressor and rear air bottle, manually traverse turret so gun launcher is positioned over rear deck. This method of entry prevents damage to stowed ammo in racks under gun/launcher.</u></p>		
1	Perform before-operation preventive- maintenance checks and services (table 4-1, steps 1 through 19).	
2	Secure turret traverse lock	2-20/C
3	Make certain that missiles and ammunition are properly stowed and secured in racks.	3-3
4	TURN OFF ALL COMMUNICATIONS AND ACCESSORY SWITCHES	2-19, 7-4
5	Install M48 periscope for driver's night vision if required	2-7
6	Secure driver's rotatable hatch cover in open or closed position	2-5/3, 13
7	Open both fuel tank valves	5-3/A
8	Make certain fixed fire extinguisher is charged and actuating handles are safety wired.	1-1/8, 2-6
9	Stand by with portable fire extinguisher	2-18/A
10	Turn vehicle MASTER SWITCH on. MASTER SWITCH lamp will illuminate.	2-10
11	Check driver's periscopes washers and wipers	2-7
12	Check FUEL gage Add fuel if required Remove both filler caps when refueling to vent entrapped air	2-9 5-3/C
<p><b>CAUTION:</b> <u>Do not run vehicle completely out of fuel. Injectors require full fuel return flow for cooling.</u></p>		

TABLE 2-3. STARTING, DRIVING, AND STOPPING VEHICLE - Continued

STEP	PROCEDURE	REFERENCE
<b>STARTING ENGINE</b>		
13	Depress service brake pedal and pull out and up on parking BRAKE LOCK handle to set brake.	2-5/6, 8
14	Place water steer lever in LAND position <b>WARNING:</b> <u>Be sure water steer lever is in LAND position to prevent damage to transmission and possible loss of vehicle control.</u>	2-6/F
15	Place transmission shift lever in N(neutral) position <b>CAUTION:</b> <u>Make certain that neutral safety switch roller contacts transmission shift control lever near center of actuating end when in N (neutral) position but is open in all other shift positions.</u>	2-6/F
16	Turn SPEED/RPM indicator switch to RPM position	2-10
17	Make sure fuel shutoff knob is pushed in	2-6C
18	Press ENGINE STARTER switch to START position <b>CAUTION:</b> <u>Do not operate starter over 15 seconds. If engine does not start, refer to troubleshooting procedure, table 5-1, steps 1 and 2. Allow 5 minute cooling-off period before again attempting to start.</u>	2-10
19	When engine starts, pull out hand throttle control knob and set to 1500 rpm (fast idle) on tachometer indicator <b>CAUTION:</b> <u>During engine warm-up, refer to indicator panel checkout procedure.</u>	2-6/E and 2-9 2-9
20	Turn SPEED/RPM indicator switch to SPEED position	2-10
<b>DRIVING VEHICLE ON LAND</b>		
<b>CAUTION:</b> <u>Until the driver becomes familiar with the vehicle, every precaution must be taken not to over-drive or allow loss of vehicle control. Make certain that gun is straight forward when traveling through wooded areas to prevent damage to grenade projector mounts.</u>		
<b>WARNING:</b> <u>Do not coast down grade. Keep engine speed matched to vehicle speed to avoid losing steering capability.</u>		
21	Apply pressure on brake pedal, pull out and down on parking BRAKE LOCK handle to release brake.	2-5/6,8
22	With brake pedal depressed, hand throttle control knob pushed in, shift from N (neutral) to desired range.	2-6/F
23	Release brake pedal and depress accelerator pedal to attain desired vehicle speed.	2-5/8, 19

TABLE 2-3. STARTING, DRIVING, AND STOPPING VEHICLE - Continued

STEP	PROCEDURE	FIG/ITEM																												
	<p style="text-align: center;"><b>DRIVING VEHICLE ON LAND - Continued</b></p> <p><b>WARNING:</b> <u>If track is thrown while operating vehicle, do not apply brake. Allow vehicle to coast to stop.</u></p> <p><b>NOTE.</b> <u>Pivot steer capability is in 1st (Low) and both reverse shift ranges in LAND position.</u></p> <p style="text-align: center;"><b>OPERATING RANGES FOR NORMAL/UNUSUAL CONDITIONS</b></p> <table border="1" data-bbox="316 590 1227 1056"> <thead> <tr> <th data-bbox="316 590 557 705">SHIFT RANGE</th> <th data-bbox="557 590 745 705">MIN. FULL THROTTLE SPEED</th> <th data-bbox="745 590 898 705">MAX SPEED</th> <th data-bbox="898 590 1227 705">GROUND CHARACTERISTICS</th> </tr> </thead> <tbody> <tr> <td data-bbox="316 705 557 800">1st - (Low)</td> <td data-bbox="557 705 745 800">3</td> <td data-bbox="745 705 898 800">7 MPH</td> <td data-bbox="898 705 1227 800">Mud, snow, deep sand, high hills, and steep grades.</td> </tr> <tr> <td data-bbox="316 800 557 894">2nd - (Low Intermediate)</td> <td data-bbox="557 800 745 894">5</td> <td data-bbox="745 800 898 894">10 MPH</td> <td data-bbox="898 800 1227 894">Semi-hard surface, low obstructions, and moderate slopes.</td> </tr> <tr> <td data-bbox="316 894 557 947">3rd - (High Intermediate)</td> <td data-bbox="557 894 745 947">8</td> <td data-bbox="745 894 898 947">19 MPH</td> <td data-bbox="898 894 1227 947">Hard surface and rolling terrain.</td> </tr> <tr> <td data-bbox="316 947 557 978">4th - (High)</td> <td data-bbox="557 947 745 978">19</td> <td data-bbox="745 947 898 978">43 MPH</td> <td data-bbox="898 947 1227 978">Flat and hard surfaces.</td> </tr> <tr> <td data-bbox="316 978 557 1010">1st Reverse</td> <td data-bbox="557 978 745 1010"></td> <td data-bbox="745 978 898 1010">5 MPH</td> <td data-bbox="898 978 1227 1010">Use as required.</td> </tr> <tr> <td data-bbox="316 1010 557 1056">2nd Reverse</td> <td data-bbox="557 1010 745 1056"></td> <td data-bbox="745 1010 898 1056">9 MPH</td> <td data-bbox="898 1010 1227 1056">Use as required.</td> </tr> </tbody> </table>	SHIFT RANGE	MIN. FULL THROTTLE SPEED	MAX SPEED	GROUND CHARACTERISTICS	1st - (Low)	3	7 MPH	Mud, snow, deep sand, high hills, and steep grades.	2nd - (Low Intermediate)	5	10 MPH	Semi-hard surface, low obstructions, and moderate slopes.	3rd - (High Intermediate)	8	19 MPH	Hard surface and rolling terrain.	4th - (High)	19	43 MPH	Flat and hard surfaces.	1st Reverse		5 MPH	Use as required.	2nd Reverse		9 MPH	Use as required.	
SHIFT RANGE	MIN. FULL THROTTLE SPEED	MAX SPEED	GROUND CHARACTERISTICS																											
1st - (Low)	3	7 MPH	Mud, snow, deep sand, high hills, and steep grades.																											
2nd - (Low Intermediate)	5	10 MPH	Semi-hard surface, low obstructions, and moderate slopes.																											
3rd - (High Intermediate)	8	19 MPH	Hard surface and rolling terrain.																											
4th - (High)	19	43 MPH	Flat and hard surfaces.																											
1st Reverse		5 MPH	Use as required.																											
2nd Reverse		9 MPH	Use as required.																											
24	<p><b>NOTE.</b> <u>Do not operate vehicle in the above shift ranges below minimum full throttle speed, downshift to the next lower shift range to prevent transmission overheating.</u></p> <p>Down-shift as required but do not force transmission shift lever.</p> <p style="text-align: center;"><b>DOWN-SHIFT MAXIMUM (SAFE) SPEEDS</b></p> <p style="text-align: center;"><b>SHIFT RANGES AND MAXIMUM (SAFE) SPEEDS</b></p> <table data-bbox="397 1377 1182 1556"> <tbody> <tr> <td>1st to Neutral . . . . .</td> <td>3 MPH</td> </tr> <tr> <td>2nd to 1st . . . . .</td> <td>5 MPH</td> </tr> <tr> <td>3rd to 2nd . . . . .</td> <td>10 MPH</td> </tr> <tr> <td>4th to 3rd . . . . .</td> <td>19 MPH</td> </tr> <tr> <td>1st Reverse to Neutral. . . . .</td> <td>2 MPH</td> </tr> <tr> <td>2nd Reverse to 1st Reverse . . . . .</td> <td>5 MPH</td> </tr> </tbody> </table>	1st to Neutral . . . . .	3 MPH	2nd to 1st . . . . .	5 MPH	3rd to 2nd . . . . .	10 MPH	4th to 3rd . . . . .	19 MPH	1st Reverse to Neutral. . . . .	2 MPH	2nd Reverse to 1st Reverse . . . . .	5 MPH	2-6/E																
1st to Neutral . . . . .	3 MPH																													
2nd to 1st . . . . .	5 MPH																													
3rd to 2nd . . . . .	10 MPH																													
4th to 3rd . . . . .	19 MPH																													
1st Reverse to Neutral. . . . .	2 MPH																													
2nd Reverse to 1st Reverse . . . . .	5 MPH																													
25	<p><b>CAUTION:</b> <u>To steer vehicle, use an even steady pull on steer bar; do not jerk. Return to center position in same manner.</u></p> <p>Turn vehicle to left (forward or reverse) by pulling on left-hand grip of steer bar.</p>	2-5/4																												
26	<p>Turn vehicle to right (forward or reverse) by pulling on right-hand grip of steer bar.</p> <p><b>CAUTION:</b> <u>Shift from forward to reverse, or reverse to forward only after bringing vehicle to a complete stop.</u></p>	2-5/4																												

TABLE 2-3. STARTING! DRIVING, AND STOPPING VEHICLE - Continued

STEP	PROCEDURE	REFERENCE
<b>DRIVING VEHICLE ON LAND - Continued</b>		
27	Perform during-operation preventive-maintenance checks and services if tactical situation permits (table 4-1, steps 64 through 67). <b>NOTE</b> <u>In case of emergency, driver can escape by his escape hatch or through the turret by pulling pin safety clip chains securipg vertical ammo rack and screens to turret ring.</u>	2-6/A and 2/27
<b>STOPPING VEHICLE AND ENGINE</b>		
28	Release accelerator pedal, depress brake pedal, and stop vehicle	2-5/8, 19
29	With brake pedal depressed, position transmission shift lever in N (neutral) position, pull out and up on parking BRAKE LOCK handle to lock brake.	2-5/6, 8, 14
30	Turn SPEED/RPM indicator switch to RPM position	2-10
31	Set hand throttle control knob to run engine at 1000 - 1300 rpm on tachometer indicator for 3 to 5 minutes	2-5/17 and 2-9
32	Push hand throttle control knob in to return engine to normal idle speed.	2-5/17
33	Turn radio and all accessories off	2-19, 7-4
34	Pull out on engine FUEL SHUT-OFF control handle to stop engine <b>CAUTION:</b> <u>Do not apply excessive pull on handle when stopping engine.</u>	2-6/C
35	<b>NOTE</b> <u>If FUEL SHUT-OFF valve does not operate properly, open engine exhaust grille and disconnect fuel line at primary fuel filter.</u>	5-2/C
36	Turn vehicle MASTER SWITCH off	2-10
36	Perform after-operation preventive-maintenance checks and services (table 4-1, steps 74 through 100).	

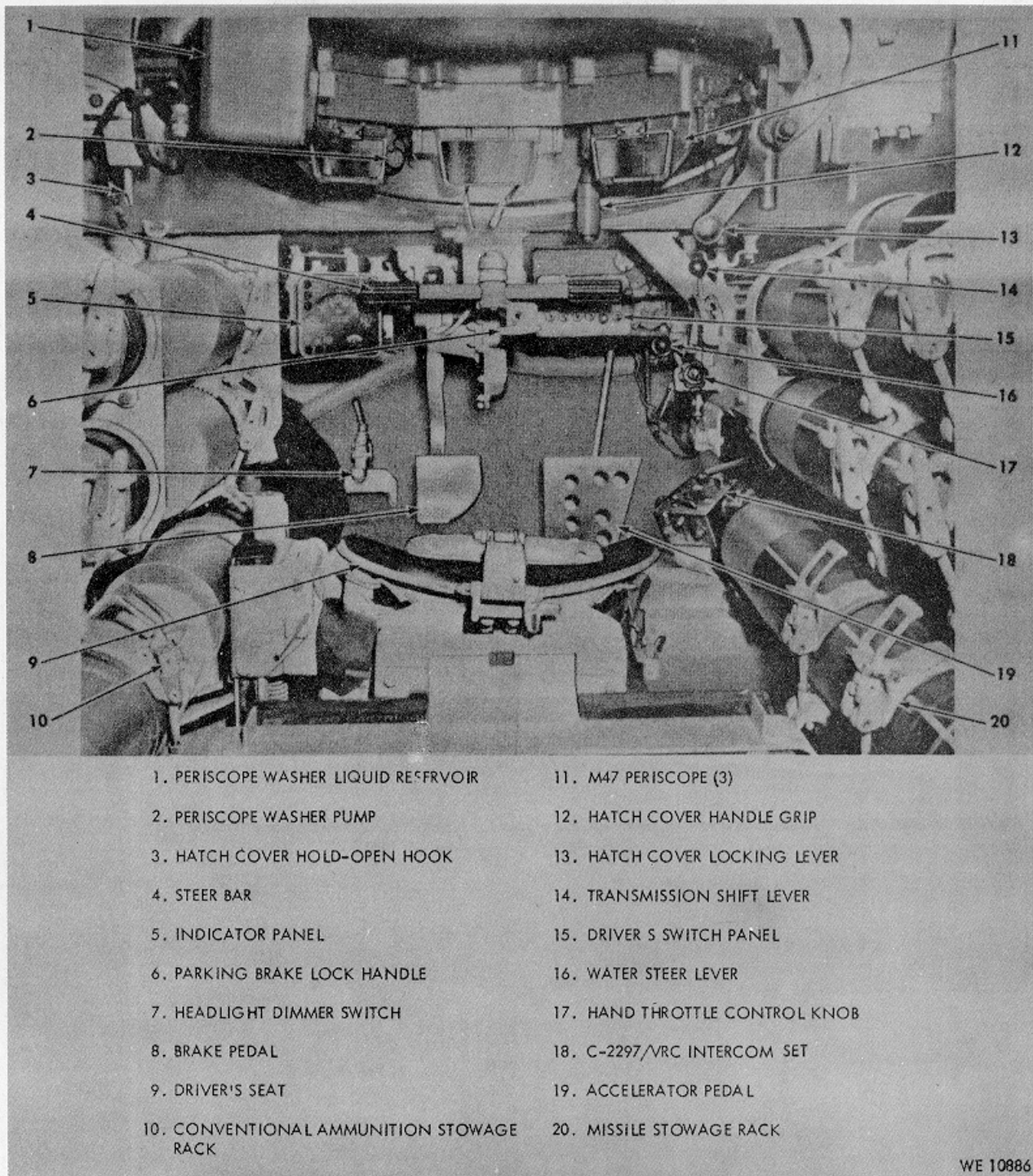

Figure 2-5. Driver's compartment

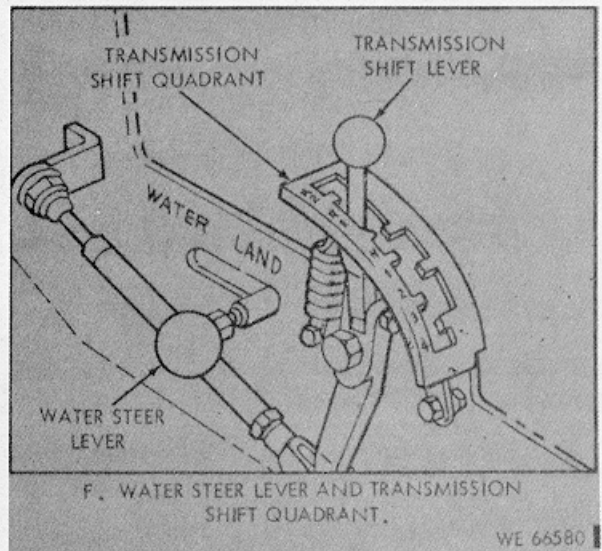
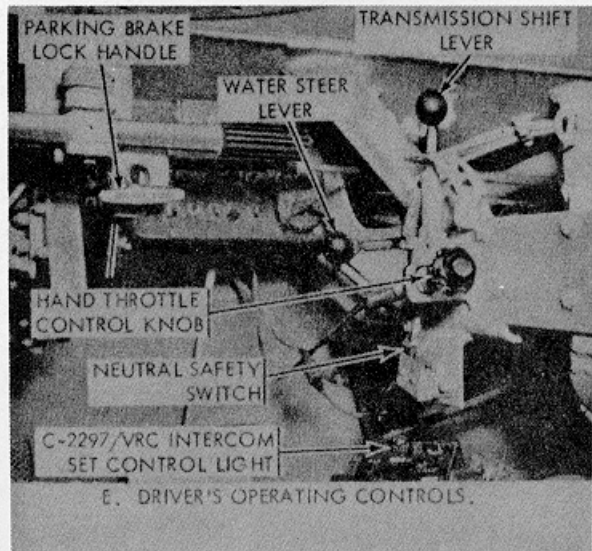
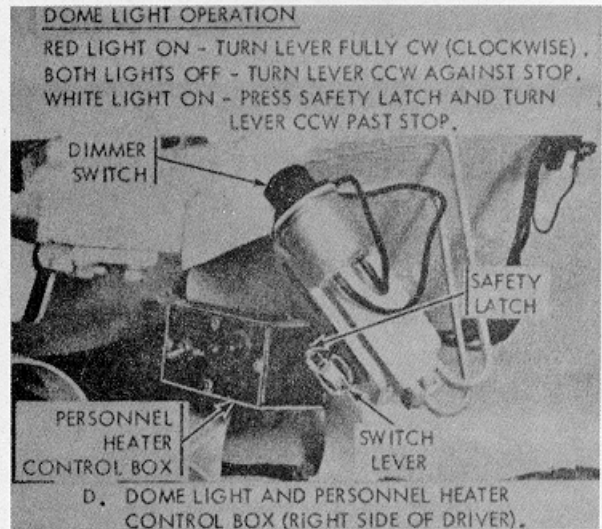
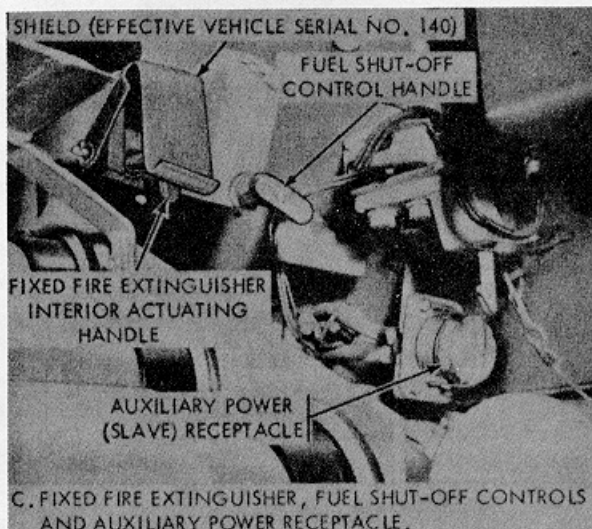
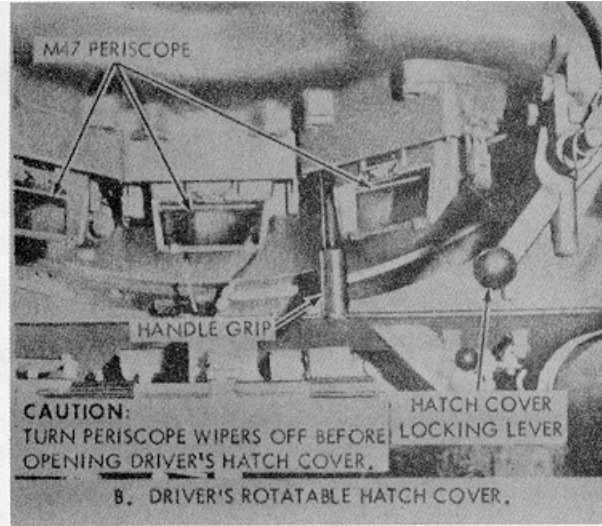
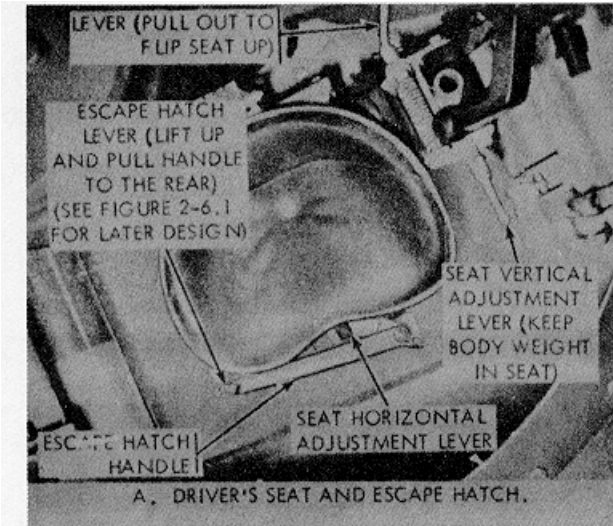
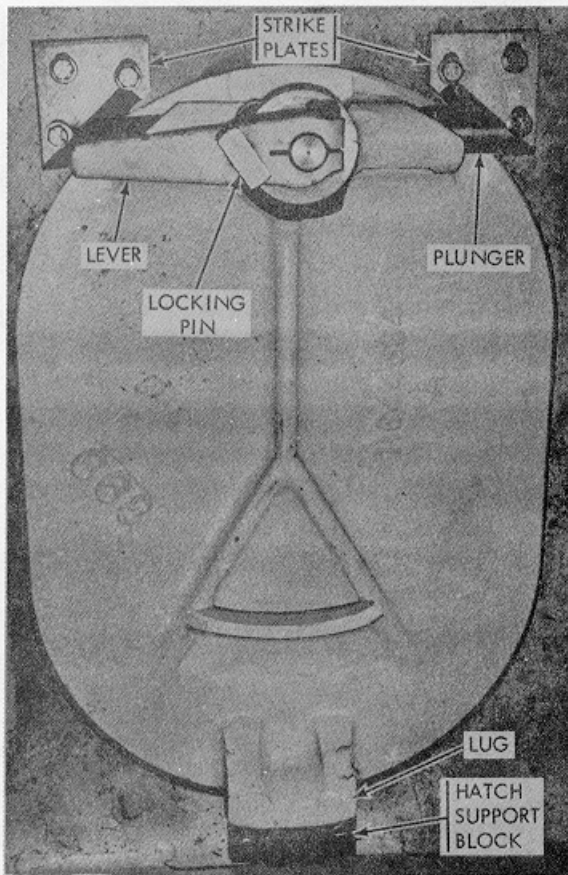
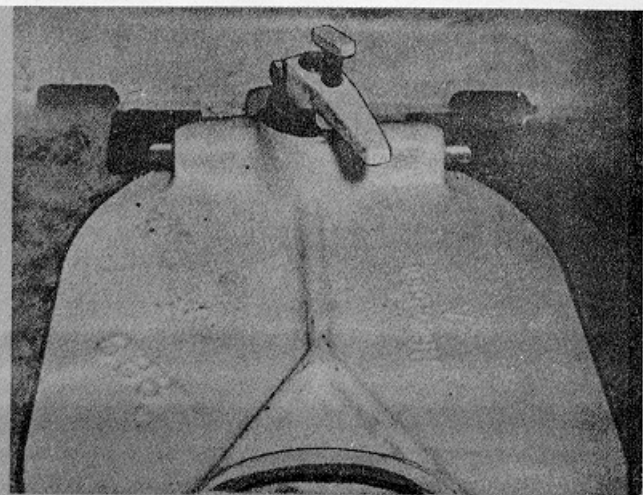

Figure 2-6. Driver's miscellaneous controls





A. DRIVER'S STEEL ESCAPE HATCH OVERALL VIEW.



B. UNLATCHED POSITION.

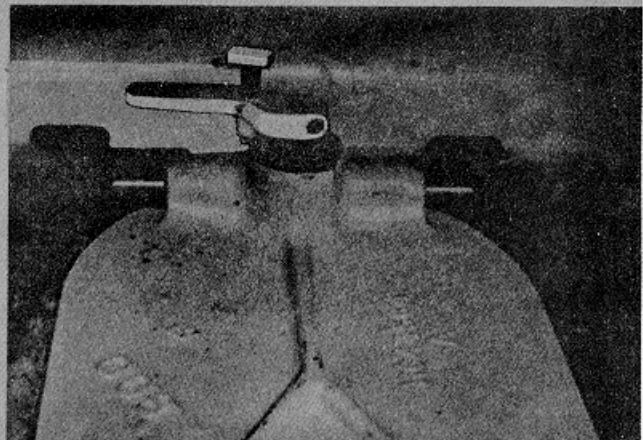

C. LATCHED POSITION - LOCKING PIN NOT ENGAGED.



D. OPERATING POSITION - LATCHED AND LOCKED.

REMOVAL

1. UNSCREW LOCKING PIN.
2. MOVE LEVER TO POSITION SHOWN IN VIEW B. HATCH COVER WILL DROP OUT.

INSTALLATION (2 MEN)

1. FROM BENEATH VEHICLE, LIFT COVER INTO PLACE IN HATCH OPENING WITH LUG AT REAR OF COVER HOOKED OVER HATCH SUPPORT BLOCK. USE JACK IF AVAILABLE TO SUPPORT HATCH COVER.
2. ALIGN COVER IN OPENING WITH LUG CENTERED ON HATCH SUPPORT BLOCK AND COVER PUSHED TO REAR AS FAR AS POSSIBLE.
3. MOVE LEVER TO LATCHED POSITION (VIEW C).

NOTE. IF LEVER IS EASY TO MOVE INTO LATCHED POSITION, HATCH COVER WILL NOT BE PROPERLY SEALED. NOTIFY ORGANIZATIONAL MAINTENANCE.

4. SCREW LOCKING PIN DOWN INTO DETENT (VIEW D).

CAUTION: DO NOT OPERATE VEHICLE WITHOUT LOCKING PIN SCREWED DOWN.

WE 66574

Figure 2-6.1. Removal/installation - driver's steel escape hatch cover.  
2-10.1

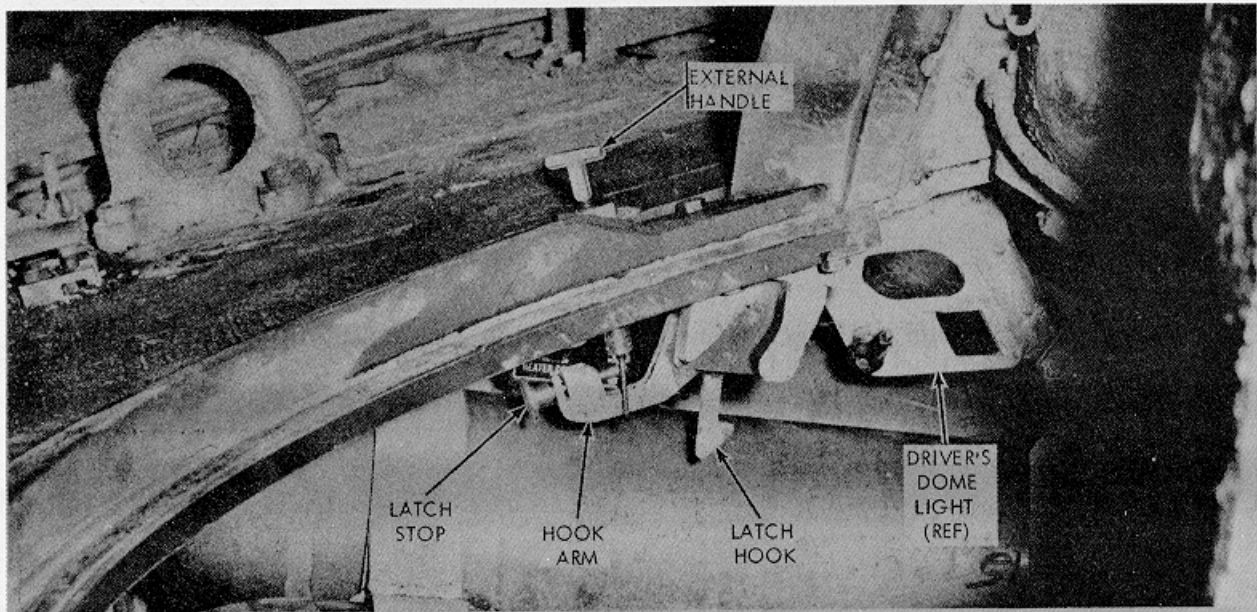

**EMERGENCY OUTSIDE LATCH RELEASE**

TO OPEN HATCH FROM DRIVER'S STATION

RETRACT LATCH STOP, AND PUSH UP ON HOOK ARM TO RELEASE LATCH HOOK. RELEASE HATCH COVER LOCKING LEVER (FIG. 2-6) AND ROTATE HATCH COVER.

TO CLOSE HATCH FROM DRIVER'S STATION

RETRACT LATCH STOP AND ROTATE HATCH COVER TO CLOSED POSITION. PUSH HATCH COVER LOCKING LEVER (FIG. 2-6) TO LOCKED POSITION, THEN PUSH LATCH STOP IN TO LOCK LATCH HOOK.

TO OPEN HATCH FROM OUTSIDE VEHICLE

TURN EXTERNAL HANDLE COUNTERCLOCKWISE SIX OR MORE FULL TURNS, THEN PULL HANDLE UP TO RELEASE LATCH HOOK. ROTATE HATCH COVER.

TO RESET EXTERNAL RELEASE MECHANISM

TURN EXTERNAL RELEASE HANDLE CLOCKWISE SIX FULL TURNS.

**CAUTION:** EXTERNAL RELEASE MECHANISM MUST ALWAYS BE RESET AFTER USE, BEFORE OPERATING VEHICLE.

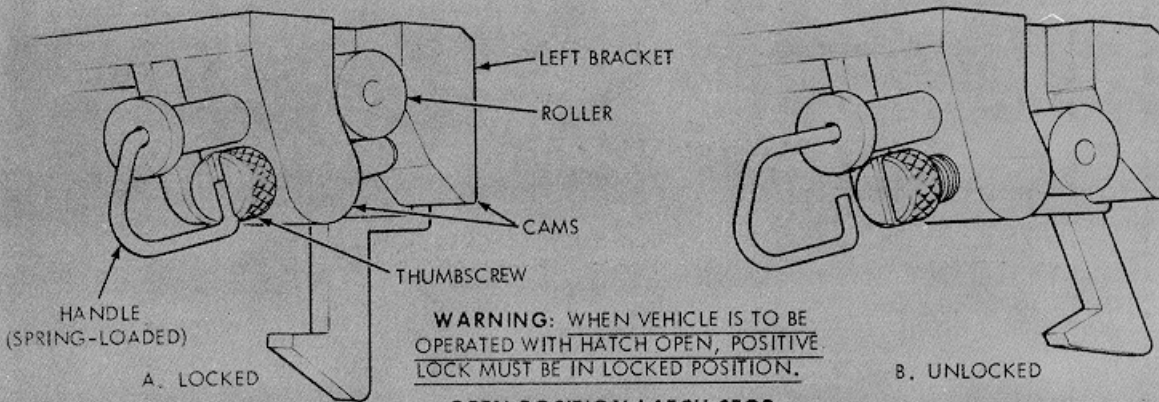

**WARNING:** WHEN VEHICLE IS TO BE OPERATED WITH HATCH OPEN, POSITIVE LOCK MUST BE IN LOCKED POSITION.

**OPEN POSITION LATCH STOP**

TO CLOSE HATCH COVER

PULL POSITIVE LOCK HANDLE TO CLEAR NOTCH IN HEAD OF THUMBSCREW, AND TURN THUMBSCREW COUNTERCLOCKWISE UNTIL END OF SCREW IS FLUSH WITH CAM. RELEASE HATCH COVER LOCKING LEVER (FIG. 2-6) AND ROTATE HATCH COVER.

TO LOCK HATCH COVER OPEN

PUSH HATCH COVER LOCKING LEVER (FIG. 2-6) TO LOCKED POSITION. PULL POSITIVE LOCK HANDLE TO CLEAR NOTCH IN HEAD OF THUMBSCREW, AND TURN THUMBSCREW CLOCKWISE TO POSITION SHOWN IN VIEW A, WITH HANDLE ENGAGING SLOT IN THUMBSCREW HEAD.

WE 66704

Figure 2-6.2. Driver's rotatable hatch emergency outside latch release and open position latch stop



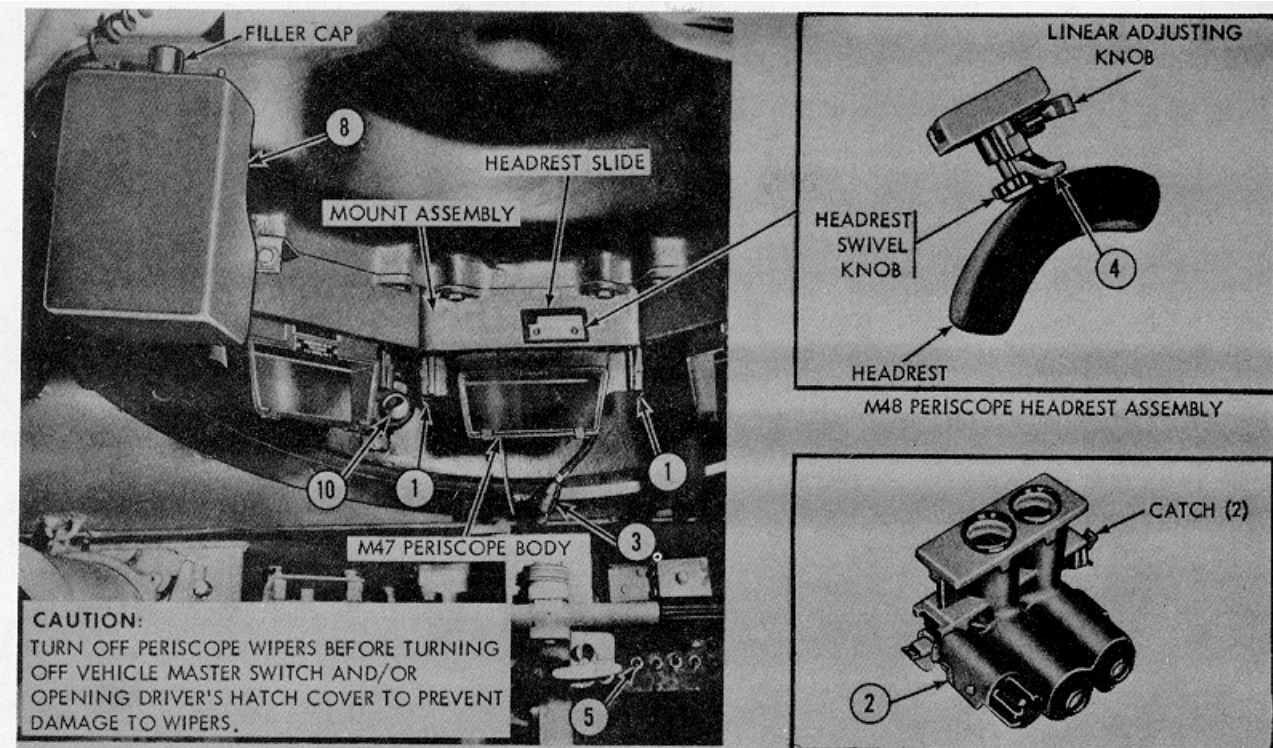

STEP	PROCEDURE
<b>INSTALLATION OF M48 PERISCOPE</b>	
CAUTION: ENSURE THAT VEHICLE MASTER SWITCH IS IN "OFF" POSITION.	
1	RELEASE 2 CATCHES SECURING CENTER M47 PERISCOPE BODY TO MOUNT ASSEMBLY AND REMOVE BODY.
2	INSTALL M48 PERISCOPE BODY ASSEMBLY BY PUSHING UP AGAINST HEAD ASSEMBLY AND SECURE WITH 2 CATCHES TO MOUNT ASSEMBLY.
3	CONNECT VEHICLE POWER SUPPLY CABLE TO M48 PERISCOPE (FIG. 5-8).
4	PULL OUT SLIDE ADJUSTING PLUNGER AND INSTALL HEADREST.
<b>OPERATION OF M48 PERISCOPE</b>	
5	TURN VEHICLE MASTER SWITCH ON.
6	HOLD LIGHT SWITCH ASSEMBLY SWITCH IN "UNLOCK" POSITION, PLACE MAIN LIGHT SWITCH IN "B.O. DRIVE" POSITION AND RELEASE SAFETY SWITCH (FIG. 2-8).
7	TURN "IR/BO" SWITCH TO "IR" POSITION (FIG. 2-8).
<b>OPERATION OF PERISCOPE WASHERS AND WIPERS</b>	
8	MAKE SURE LIQUID RESERVOIR IS FILLED.
9	TURN VEHICLE MASTER SWITCH ON (ITEM 5).
10	PUSH IN WASHER PUMP TO SPRAY PERISCOPE WINDOWS
11	TURN WINDSHIELD WIPERS SWITCH (FIG. 2-10) TO "ON" POSITION TO ACTUATE WIPERS.

WE 10916

Figure 2-7. Installation and operation of driver's M48 periscope  
(2-12 Blank) 2-11

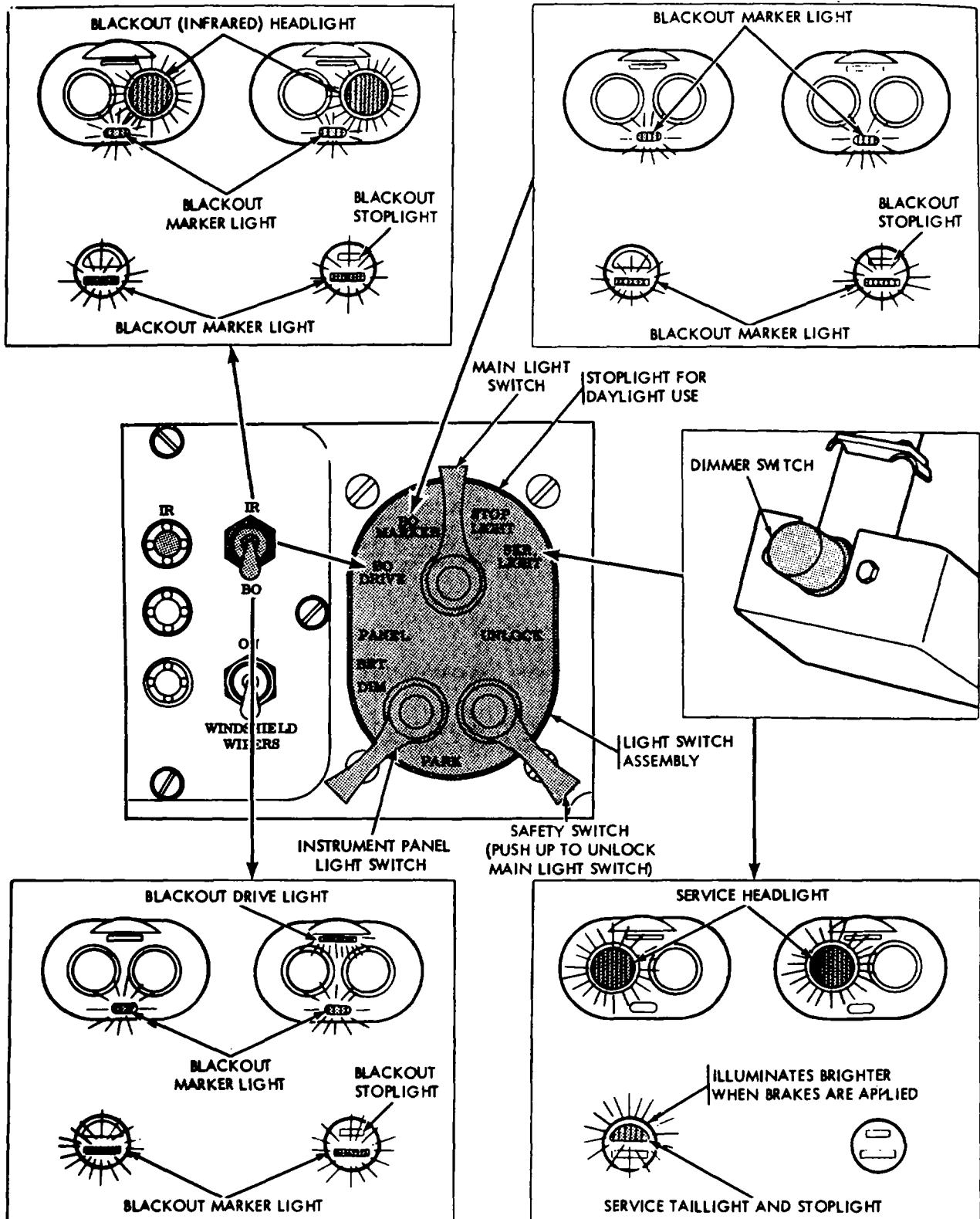

WE 10890

Figure 2-8. Vehicle driving lights chart

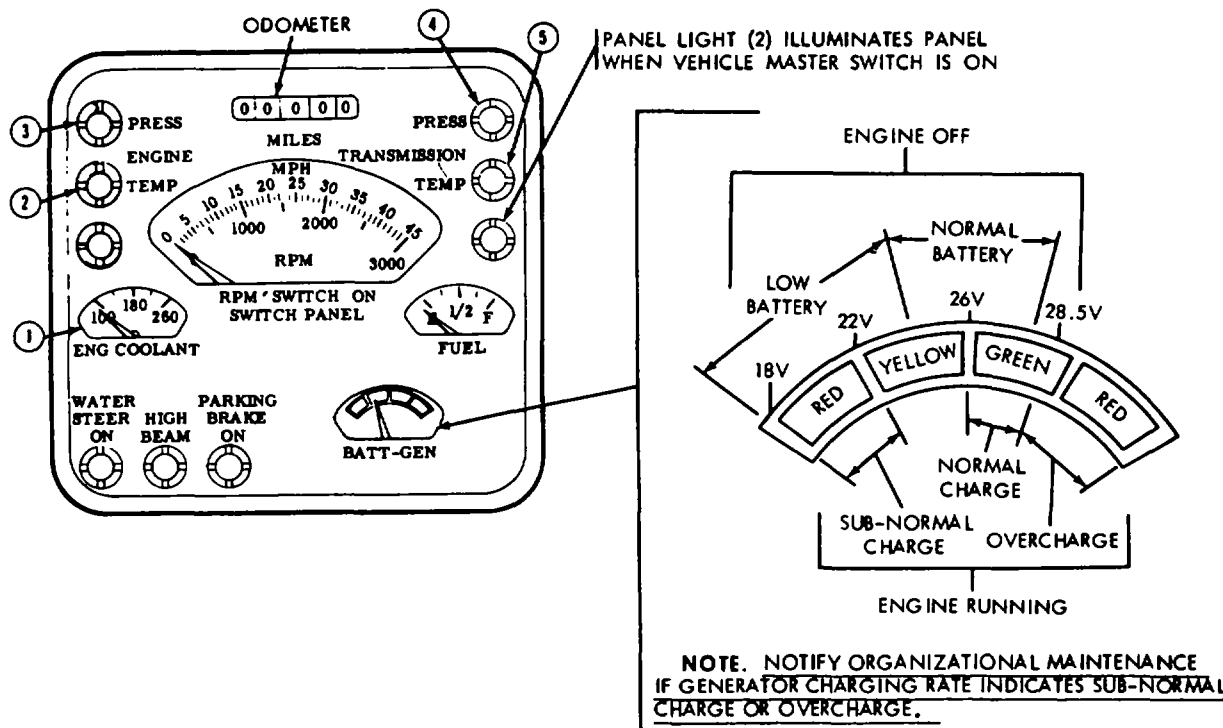

1. ENGINE COOLANT TEMPERATURE GAGE. TEMPERATURE GAGE SHOULD NORMALLY READ 175'210'F.
2. ENGINE COOLANT TEMPERATURE WARNING LIGHT. WARNING LIGHT WILL COME ON IF ENGINE TEMPERATURE REACHES 225°F (CHECK AGAINST ENGINE COOLANT TEMPERATURE GAGE). STOP ENGINE AND CHECK FOR:
  - a. LOW COOLANT LEVEL IN SURGE TANK--FILL SYSTEM.
  - b. DEBRIS ON INTAKE GRILLE OR RADIATOR-REMOVE DEBRIS.
  - c. BROKEN COOLANT PUMP BELTS--NOTIFY ORGANIZATIONAL MAINTENANCE.

IF, AND **ONLY IF** NONE OF THE ABOVE PROBLEMS ARE FOUND, LOCK COOLANT FAN CLUTCH IN DIRECT DRIVE (B, FIGURE 5-2) FCR EMERGENCY OPERATION. NOTIFY ORGANIZATIONAL MAINTENANCE.

3. ENGINE LOW OIL PRESSURE WARNING LIGHT. IF WARNING LIGHT REMAINS ON AT 1300 RPM, INDICATING LESS THAN 9-13 PSI PRESSURE, STOP ENGINE AND CHECK OIL LEVEL. IF OIL IS AT PROPER LEVEL, NOTIFY ORGANIZATIONAL MAINTENANCE.
4. TRANSMISSION LOW OIL PRESSURE WARNING LIGHT. IF WARNING LIGHT REMAINS ON AT 1500 RPM, INDICATING LESS THAN 4-8 PSI PRESSURE, STOP ENGINE AND CHECK OIL LEVEL. IF OIL LEVEL IS CORRECT, NOTIFY ORGANIZATIONAL MAINTENANCE.
5. TRANSMISSION OIL TEMPERATURE WARNING LIGHT. WARNING LIGHT INDICATES OVERHEATED TRANSMISSION. PLACE SHIFT SELECTOR IN NEUTRAL POSITION AND IDLE AT 1300 RPM FOR THREE MINUTES. IF LIGHT REMAINS ON, NOTIFY ORGANIZATIONAL MAINTENANCE.

WE 12036

Figure 2-9. Driver's indicator panel

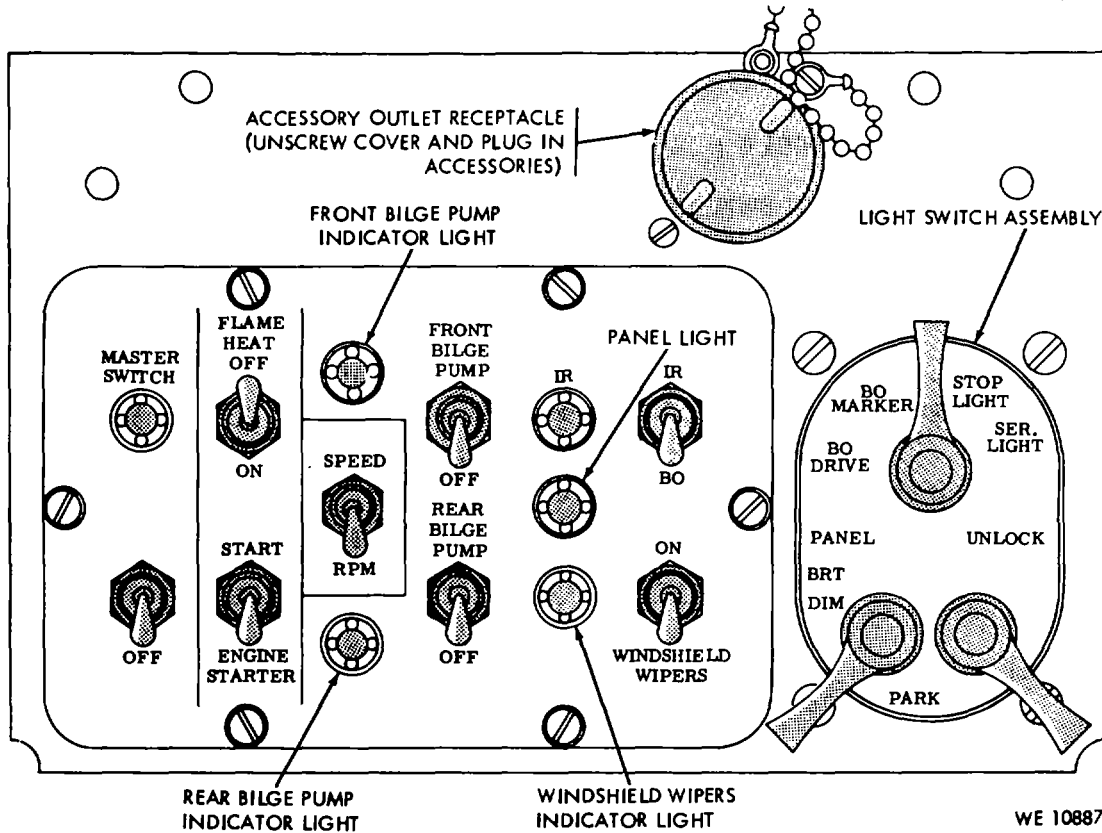

Figure 2-10. Driver's switch panel

TABLE 2-4. AMPHIBIOUS OPERATION

STEP	PROCEDURE	REFERENCE
1	<p style="text-align: center;"><b>PREPARING VEHICLE FOR AMPHIBIOUS OPERATION</b></p> <p>Perform before-operation preventive-maintenance checks and services (table 4-1, steps 1 through 19).</p> <p><b>WARNING:</b> <u>The crew should be thoroughly trained on procedures for evacuating the vehicle in water prior to amphibious operation.</u></p> <p><b>CAUTION:</b> 1. <u>Vehicle must be combat loaded with equipment correctly stowed and secured to achieve proper balance in water</u></p> <p>2. <u>Attach tow cable to front or rear towing shackles to facilitate towing in case of power failure. Secure center portion of cable to vehicle to prevent drag or entanglement.</u></p>	<p>App. II 1-1/25 &amp; 1-2/22, 23</p>
2	<p>Be sure driver's escape hatch and drain/access plugs on hull bottom are secured. On vehicles equipped with exhaust plume diffuser, pull pin and turn diffuser upside down (off the exhaust outlet) whenever vehicle is to be operated with barrier erected.</p>	<p>2-6/A, and 5-7</p>
3	<p>Erect and secure surfboard and barrier. Make certain surfboard cavity drain cover is in place. Remove covers from front bilge pump outlets</p> <p><b>CAUTION:</b> <u>Traverse gun-launcher approximately 90 mils to the left of driver's hatch cover, prior to swimming, so driver will have additional clearance in evacuating vehicle if necessary.</u></p>	<p>2-11, 12, &amp; 2-12. 1</p>

TABLE 2-4. AMPHIBIOUS OPERATION - CONTINUED

STEP	PROCEDURE	REFERENCE
4	<p style="text-align: center;"><b>PREPARING VEHICLE FOR AMPHIBIOUS OPERATION - Continued</b></p> <p>Turn vehicle MASTER SWITCH and BILGE PUMP switches on; listen and make certain bilge pumps are operating properly. Turn BILGE PUMP switches off and start engine.</p>	2-10 and 2-13
	<b>ENTERING WATER</b>	
5	Push water steer lever forward to WATER position	2-6/F
6	Place transmission shift lever in 1st (low) position	2-6/F
	<b>WATER ENTRY CAUTIONS</b>	
	<p><b>CAUTION:</b> 1. <u>Select a gradual sloping bank of firm ground that is free of rocks, stumps, or debris to enter water. Avoid drop offs into water, soft ground or steep grades where vehicle may lose traction and mire down or skid.</u></p> <p>2. <u>Leave vehicle hatch covers open during water entry and operation if situation permits.</u></p> <p>3. <u>10 mph is maximum safe water entry speed from slopes up to 15% (1.5 ft. drop in 10 feet).</u></p> <p>4. <u>5 mph is maximum entry speed on slopes of 15 to 30%.</u></p> <p>5. <u>The vehicle should be eased into the water slowly from slopes of over 30%. The vehicle front will become buoyant before entry is completed.</u></p> <p>6. <u>Avoid steep entry slopes if at all possible. High speed entries from steep slopes not only can cause failure of flotation components, but also endanger the vehicle's personnel.</u></p> <p><b>NOTE.</b> <u>Entry technique must be controlled by good driver judgment. This can result only from adequate training and experience.</u></p>	
7	<p>Immediately upon entering water, turn BILGE PUMP switches on and shift 2-10 and to 3rd range for maximum performance</p> <p><b>WARNING:</b> <u>During water entry and vehicle swimming, if a solid stream of water continues to emit from bilge pump outlets, the vehicle should be beached immediately and the cause of leakage determined.</u></p>	2-6/F 2-12/F, G
8	<p>When turning vehicle, return steer bar to center position before turn is completed, allowing momentum of vehicle to complete turn. To obtain maximum turning response, decelerate, turn steering bar, then accelerate.</p> <p><b>NOTE.</b> <u>Propulsion and steering are same on water and land.</u></p> <p><b>CAUTION:</b> 1. <u>If engine becomes inoperative during amphibious operation, the crew should prepare to evacuate vehicle.</u></p> <p>2. <u>If it becomes necessary to tow vehicle while in water, towing speed should not exceed 5 mph.</u></p>	2-5/4

TABLE 2-4. AMPHIBIOUS OPERATION - CONTINUED

STEP	PROCEDURE	REFERENCE
<b>STOPPING THE VEHICLE IN WATER</b>		
9	Release accelerator pedal and apply brake to stop tracks	2-5/8, 19
10	Move transmission shift lever to R2 (reverse) position. Release brake and gently accelerate. <b>NOTE:</b> <u>Vehicle should be stopped when traveling in reverse in same manner, except shift lever is moved to 1st (ow) position.</u>	2-6/F
11	Release accelerator pedal when forward motion of vehicle is stopped; move transmission shift lever to N (neutral) position.	2-5/14, 19
<b>LEAVING WATER</b>		
12	Approach bank squarely, ease up on accelerator pedal to reduce track speed allowing vehicle to coast until tracks contact solid ground.	2-5/19
13	Return water steer lever to LAND position and proceed to land in 1st (low) range. <b>CAUTION:</b> <u>Leave water on hard ground, free of obstacles. Avoid mushy banks or steep slopes where vehicle may mire or stall.</u>	2-6/F
14	Stop vehicle when clear of water and on firm footing. Clear tracks and wheels of any debris.	
15	Turn bilge pumps off when all water has been removed from vehicle and stop engine. When required, driver's escape hatch may be loosened sufficiently to break seal and allow residual water to drain from vehicle.	2-13
15. 1	Install front bilge pump outlet covers	2-12. 1
16	Retract surfboard and barrier  <b>WARNING:</b> <u>Pull hands clear immediately after releasing quick-release surfboard, effective vehicle serial no. 70.</u>	2-11, 12, & 2-12. 1
17	Inspect suspension components and any other vehicle components, which may have been immersed or sprayed while swimming vehicle, for water contamination. Service according to LO 9-2350-230-12. <b>CAUTION:</b> <u>If vehicle has been submerged, retrieve vehicle, remove hull access plugs and driver's escape hatch, and immediately evacuate vehicle to appropriate supporting maintenance area for servicing, prior to any operation of vehicle components.</u>	

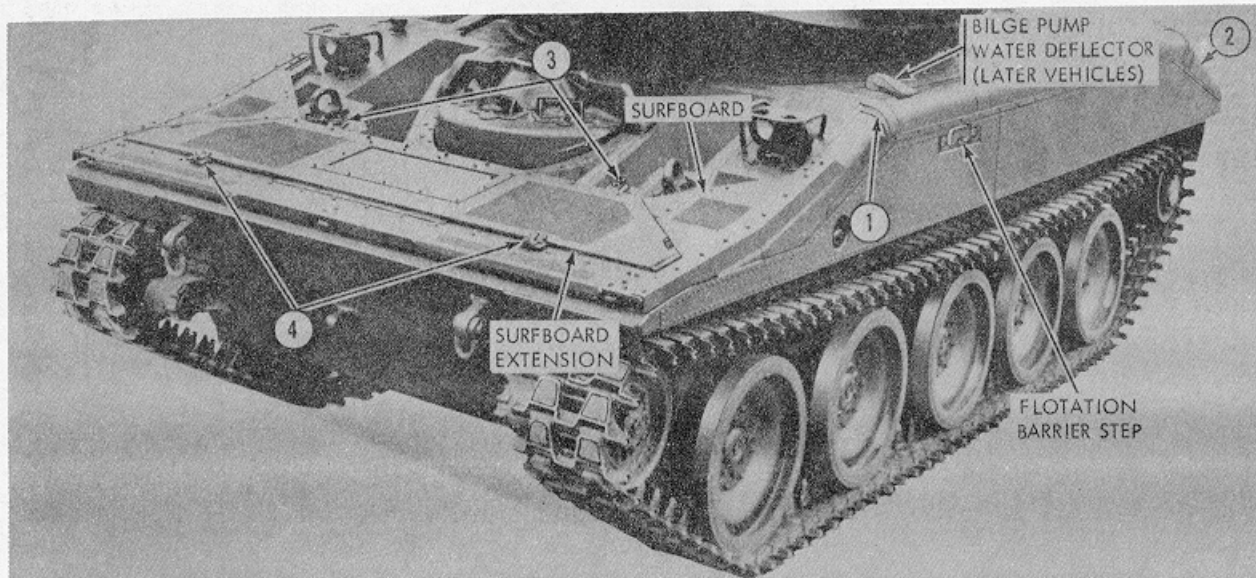

A. SURFBOARD AND BARRIER IN STOWED POSITION.

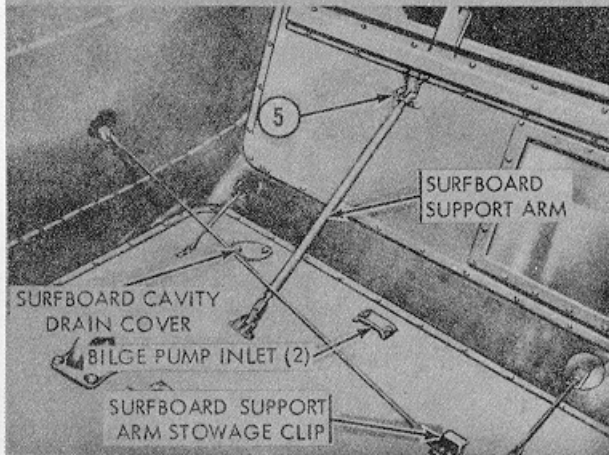

B. SURFBOARD IN ERECTED POSITION (LEFT FRONT VIEW).

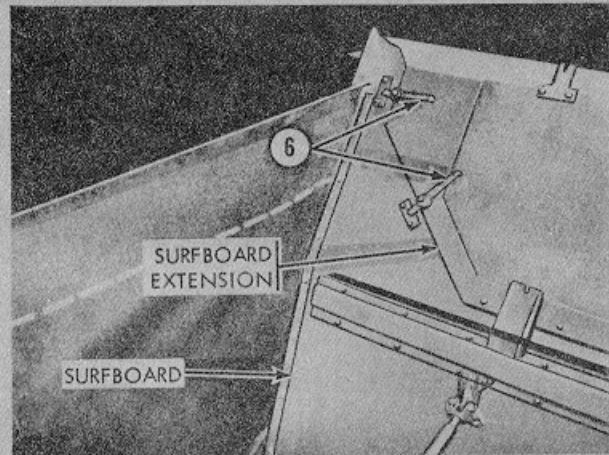

C. SURFBOARD EXTENSION IN ERECTED POSITION (LEFT FRONT VIEW).

STEP	PROCEDURE
1	RELEASE RETAINING STRAPS AND PULL SIDE BARRIER COVERS FROM STOWED POSITION. PULL OUT BARRIER FROM BARRIER TRAYS.
2	UNBUCKLE REAR COVER STRAPS AND PULL BARRIER COVER AWAY EXPOSING BARRIER.
	<b>NOTE.</b> AFTER THE ABOVE PROCEDURE IS PERFORMED FROM THE GROUND, THE CREW MOUNTS THE VEHICLE: TWO FRONT AND TWO REAR.

STEP	PROCEDURE
3	LOOSEN 2 WING NUTS AND ROTATE LOCKING SCREWS ON SURFBOARD.
4	LOOSEN 2 WING NUTS ON SURFBOARD EXTENSION.
5	RAISE SURFBOARD AND SECURE SUPPORT ARMS TO SURFBOARD WITH LOCKING PINS PROVIDED.
	<b>NOTE.</b> AT THE SAME TIME STEP NO. 5 IS BEING DONE THE REAR BARRIER IS BEING ERECTED (D, FIG. 2-12).
6	RAISE AND SECURE SURFBOARD EXTENSION WITH 4 LOCKING LEVERS.

WE11906

Figure 2-11. Erecting flotation surfboard and barrier (through vehicle serial no. 69)  
(1 of 2)



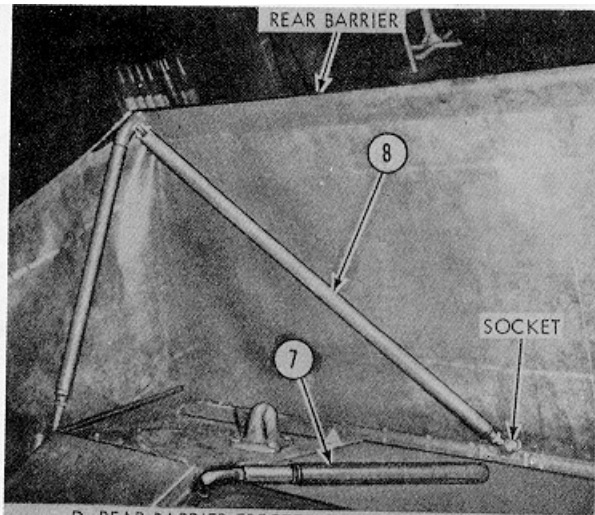

D. REAR BARRIER ERECTED (RIGHT REAR VIEW).

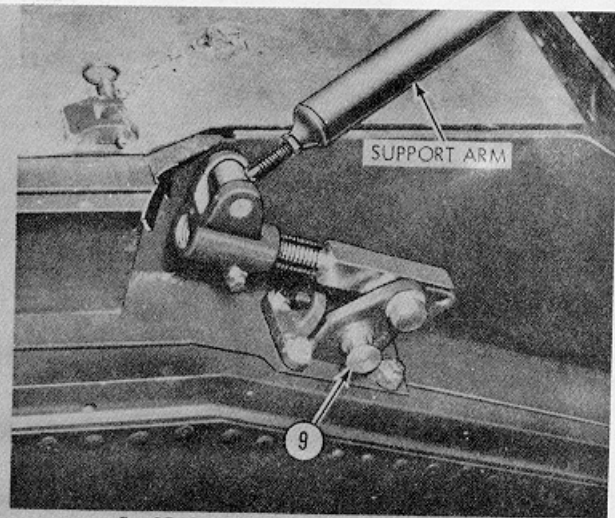

E. REAR BARRIER LEFT SUPPORT ARM.

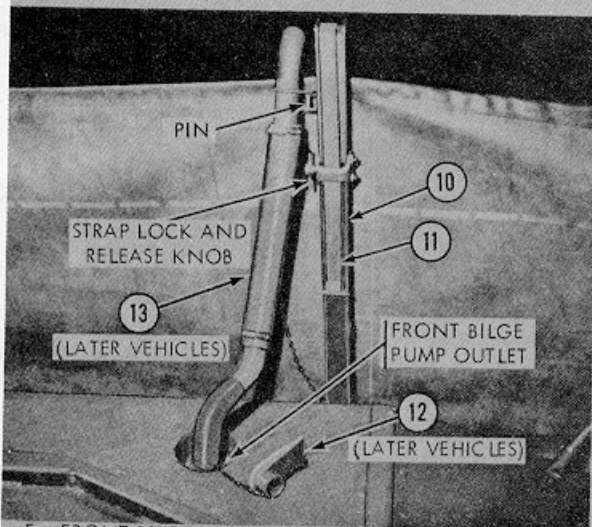

F. FRONT BILGE PUMP OUTLET HOSE (LEFT SIDE).

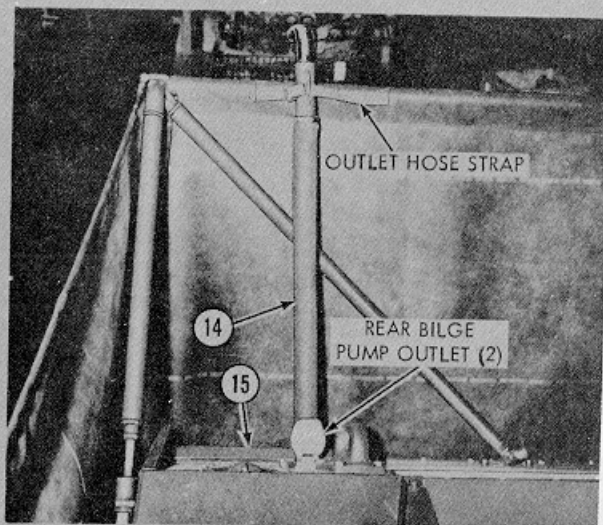

G. REAR BILGE PUMP OUTLET HOSE.

STEP	PROCEDURE
7	REMOVE 2 REAR BILGE PUMP OUTLET HOSES FROM 2 REAR DIAGONAL SUPPORTS.
8	HOLD REAR BARRIER UP AND PLACE THE 2 REAR DIAGONAL SUPPORTS INTO SOCKETS, MAKING SURE THEY ARE BOTTOMED.
9	PULL OUTWARD ON PLUNGER AND ROTATE SUPPORT ARM INTO FULLY EXTENDED POSITION UNTIL PLUNGER SNAPS IN AND LOCKS.
10	EACH CREWMEMBER INSERT 1 BARRIER SIDE POST ASSEMBLY IN SQUARE SOCKETS PROVIDED IN BARRIER TRAYS. <b>NOTE.</b> THERE ARE 4 BARRIER SIDE POSTS.

STEP	PROCEDURE
11	PLACE STRAPS OVER TOP OF POST AND PULL DOWN THROUGH STRAP LOCK TO RAISE SIDE BARRIERS. <b>NOTE.</b> TO RELEASE BARRIER ROTATE STRAP RELEASE KNOB.
12	REMOVE WATER DEFLECTOR FROM FRONT BILGE PUMP OUTLET.
13	ATTACH END OF HOSE WITH PIN INTO POST, AND OTHER END INTO BILGE PUMP OUTLET.
14	INSERT REAR BILGE PUMP OUTLET HOSES AND STRAP TO REAR BARRIER.
15	MAKE CERTAIN THAT 2 DRAIN OUTLETS IN REAR BARRIER TRAY ARE CLEAR OF DEBRIS. <b>NOTE.</b> REVERSE PROCEDURE WHEN STOWING.

WE 11905

Figure 2-12. Erecting flotation surfboard and barrier (through vehicle serial no. 69) (2 of 2)



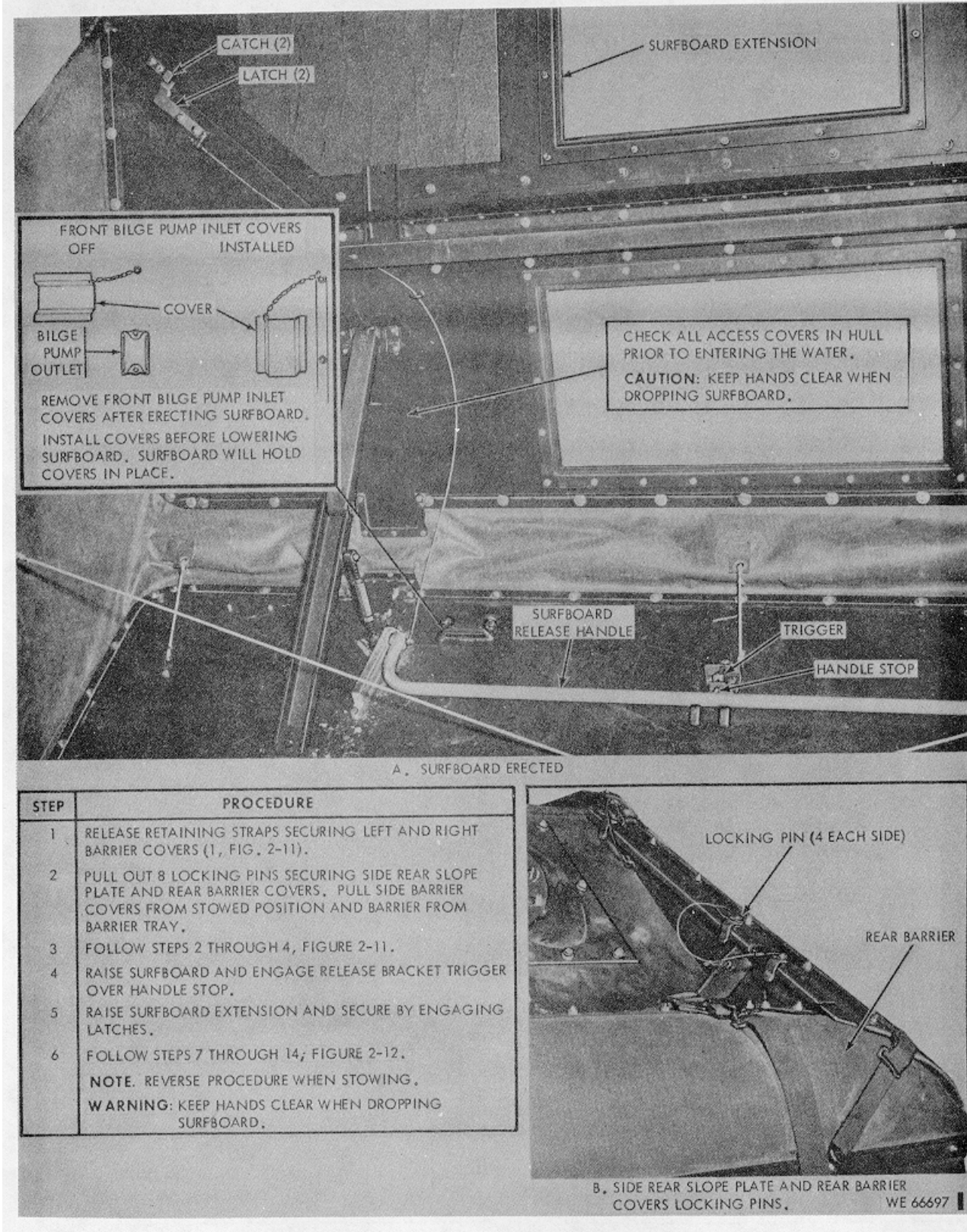
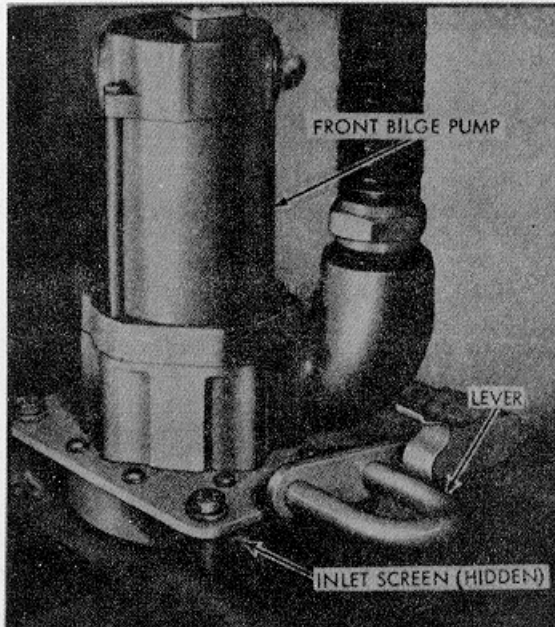

Figure 2-12.1. Erecting surfboard and barrier (effective vehicle serial no. 70)



EFFECTIVE VEHICLES SERIAL NO'S, 1 THROUGH 139

LEVER POSITION

- DOWN - EVACUATES SURFBOARD CAVITY ONLY
- UP - EVACUATES CREW AREA ONLY

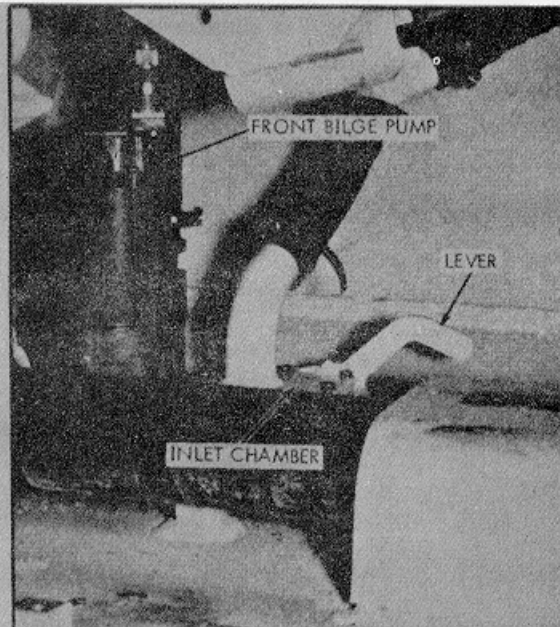

EFFECTIVE VEHICLE SERIAL NO, 140

LEVER POSITION

- UP - EVACUATES SURFBOARD CAVITY ONLY
- DOWN - EVACUATES CREW AREA ONLY

BEFORE OPERATION

TURN ON VEHICLE MASTER SWITCH AND BILGE PUMP SWITCHES TO CHECK PUMP OPERATION. IF HULL IS DRY, PLACE HAND OVER OUTLETS TO BE SURE AIR IS BEING EXPELLED.

CAUTION: DO NOT OPERATE PUMPS MORE THAN 15 MINUTES WITHOUT ENGINE RUNNING. AVOID UNNECESSARY DRY OPERATION OF THE PUMPS.

AFTER OPERATION

WHEN OPERATING UNDER DUSTY CONDITIONS OR ON SANDY TERRAIN, THE BILGE PUMP SYSTEM MUST BE THOROUGHLY FLUSHED FREQUENTLY, TO PREVENT ACCUMULATION OF SILT AND DEBRIS IN OUTLETS, INLETS AND/OR PUMP IMPELLERS. SEVERAL MINUTES OPERATION OF EACH PUMP, WITH AN ADEQUATE SUPPLY OF WATER, IS REQUIRED TO PROPERLY FLUSH THE SYSTEM. THE SURFBOARD SHOULD BE ERECTED TO PERMIT FLUSHING OF THE SURFBOARD CAVITY INLETS, AND THE LOWER INLETS OF ALL PUMPS SHOULD BE CHECKED FOR ANY ACCUMULATION OF DEBRIS OR MUD.

WE 10904B

Figure 2-13. (Superseded) Operation of bilge pumps

TABLE 2-4.1. COLD WEATHER STARTING PROCEDURE (REFER TO FIGURE 2-14)

STEP	PROCEDURE	FIG/ITEM
	<p><b>NOTE.</b> Steps marked with asterisk (*) are applicable only to vehicles with hand pump lock and air box flame heater fuel shutoff valve (B, figure 2-14). All other steps are applicable to all vehicles.</p>	
	PREPARATION FOR STARTING	
1	Traverse turret to the side and open engine compartment right exhaust grille.	1-2
*2	Open air box flame heater fuel shutoff valve.	2-14B
3	Check air box flame heater accumulator pressure gage. Pressure indicator should be in cold start area of gage. If not, use accumulator hand pump to increase pressure:	2-14
	<p>*a. Release accumulator hand pump lock.  b. Turn pump handle to release from detent, and actuate handle to increase pressure.</p>	
4	After attaining required pressure, rotate pump handle to engage detent.	
*5	Position hand pump lock to locked position.	
6	Close engine compartment exhaust grille.	
	STARTING	
7	Place transmission shift lever in "N" (neutral) position.	2-6E
8	Turn vehicle master switch ON.	2-10
9	Turn speed/RPM indicator switch to RPM.	2-10
	NOTE. <u>If engine coolant heater has been operation, proceed to step 11.</u>	
10	Pull out on fuel shutoff control knob, hold starter switch in START, and hold air box flame heater switch to ON position for 15 to 20 seconds.	2-6C
11	Push in fuel control shutoff knob, continue to hold starter switch in START, and cycle flame heater switch on and off 1 or 2 times per second, with a 2 second pause in the OFF position every 7 to 10 seconds until engine reaches 400 to 500 RPM, then depress accelerator half way and disengage starter switch.	2-10
	NOTE. <u>If engine does not commence firing after a total of 40 seconds of cranking or if the indication of cylinder firing ceases for a period of over 10 seconds, stop cranking and check the air box flame heater system components for proper operation. If a malfunction is evident, notify organizational maintenance personnel.</u>	
12	With brakes locked, move transmission shift lever to 4th position and continue operation of the engine at 1200-1500 RPM until coolant temperature gage indicates 120° to 140°F. If transmission high temperature warning light illuminates, shift to "N" (neutral) and idle at 1200-1500 RPM until light goes out.	
*13	Reopen right exhaust grille and close flame heater fuel shutoff valve. Close grille.	
	RECHARGING ACCUMULATOR	
	NOTE. <u>When through with vehicle operation for the day, reopen right exhaust grille. Recharge accumulator as follows:</u>	
*14	Open flame heater fuel shutoff valve.	
*15	Move hand pump lock to unlocked position.	
16	Release hand pump from detent position.	
17	Run engine is neutral at approximately 2000 RPM until no further increase in pressure is apparent on accumulator pressure gage.	
18	Return hand pump to detent position.	
*19	Move hand pump lock to locked position.	
*20	Close flame heater fuel shutoff valve.	
21	Close exhaust grille.	
	2-20.2	

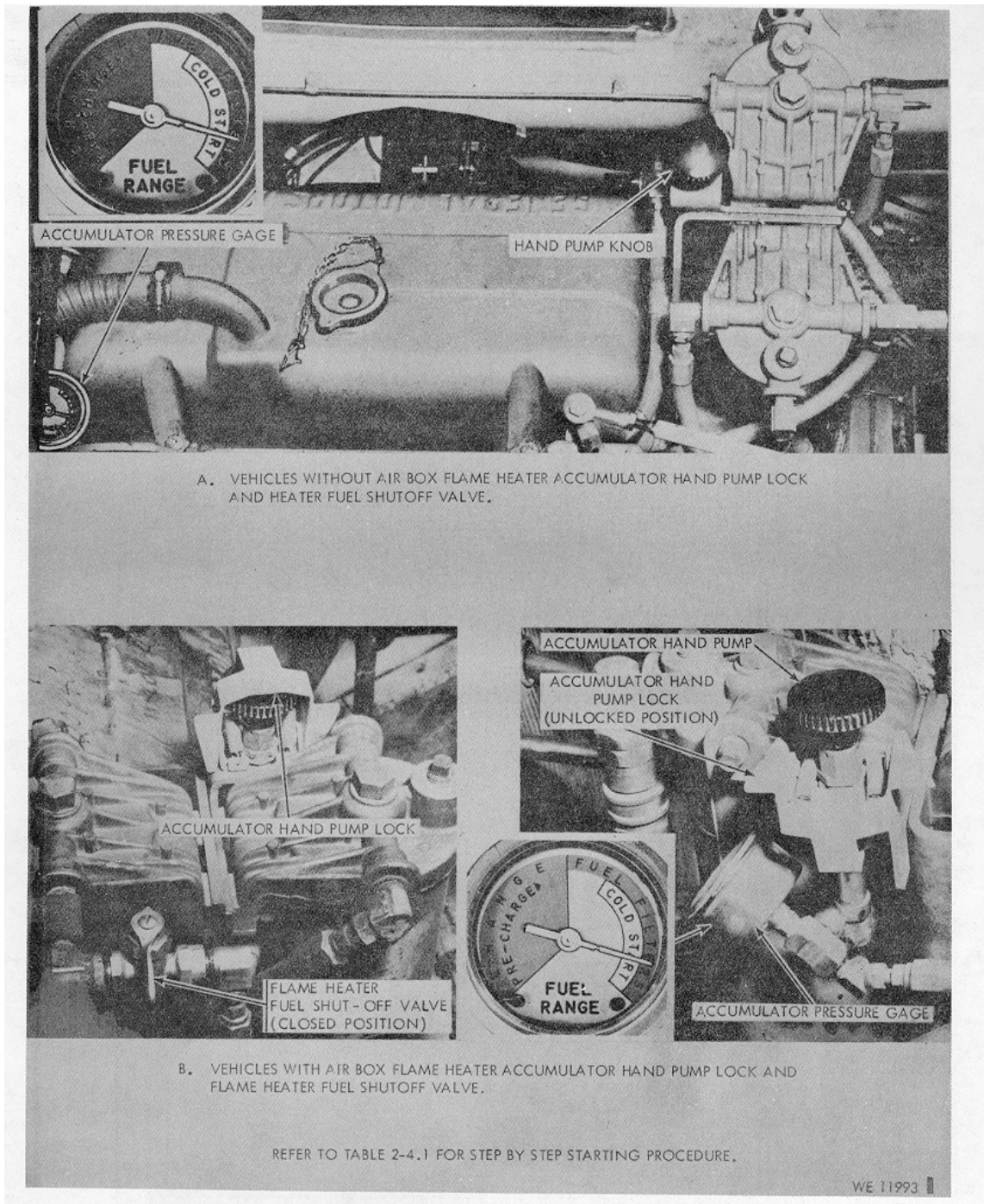

Figure 2-14. Cold weather starting

Figure 2-14.1. Deleted.

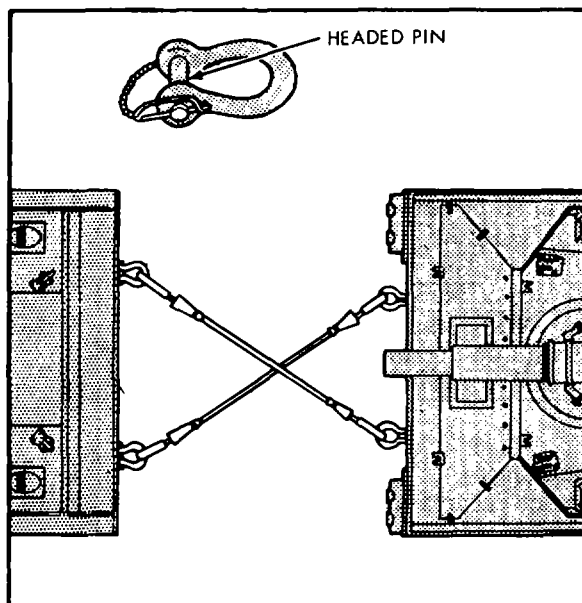

TABLE 2-5. TOWING DISABLED VEHICLE AND TOWING OR SUPPLYING AUXILIARY POWER TO START ENGINE

STEP	PROCEDURE	FIG/ITEM
<b>TOWING DISABLED VEHICLE ON LAND</b>		
1	Remove sprocket drive shafts if transmission has sustained damage. Notify organizational maintenance personnel.	
2	Connect tow bar or tow cables. 2-15	
	<b>WARNING:</b> <u>If drive shafts have been removed use tow bar only, since vehicle has no steering or braking capability.</u>	
3	Place transmission shift lever in N (neutral) position.	2-6/F
4	Release brake and signal towing vehicle.	2-5/8
	<b>WARNING:</b> <u>When towing disabled vehicle, limit speed to 5 MPH if tactical situation permits. NEVER ATTEMPT TO TURN AT SPEED EXCEEDING 5 MPH.</u>	
	<b>NOTE.</b> <u>In an emergency, vehicle may be towed in reverse direction for a distance not to exceed 1/4 mile at a speed not to exceed 5 mph in N (neutral) range. If vehicle towing distance is greater than 1/4 mile, notify organizational maintenance to remove sprocket drive shafts.</u>	
<b>TOWING VEHICLE TO START ENGINE</b>		
1	Connect tow bar or tow cables	2-15
2	Place transmission shift lever in 2nd gear range	2-6/F
3	Turn vehicle MASTER SWITCH on.	2-10
4	Place water steer lever in LAND position.	2-6/F
5	Depress brake pedal and release parking BRAKE LOCK handle.	2-5/6, 8
	<b>WARNING:</b> <u>Never attempt turns at speeds exceeding 5 MPH.</u>	
6	Choose terrain where vehicle can be towed without turning, and tow 6 to 19 MPH as required for starting.	
	<b>CAUTION:</b> <u>Do not depress accelerator pedal on towed vehicle.</u>	
7	After engine starts, move transmission shift lever to N (neutral) position 2-6/E, F and adjust hand throttle control knob to run engine at fast idle.	
8	Disconnect towing vehicle.	
<b>USING AUXILIARY POWER TO START ENGINE</b>		
1	Connect auxiliary power (slave) cable to stalled vehicle auxiliary power receptacle and to auxiliary vehicle or other power source. 2-6/C	
	<b>CAUTION:</b> 1. <u>Polarity and voltage (24v) must be identical in both vehicles.</u>	2-10
	2. <u>Be sure vehicle MASTER SWITCH is off in stalled vehicle. All accessories must be off.</u>	
	3. <u>Do not allow personnel in between vehicles during slave start operation.</u>	
	4. <u>Place transmission shift lever in neutral position and set parking brake on both vehicles.</u>	

TABLE 2-5. TOWING DISABLED VEHICLE AND TOWING OR SUPPLYING AUXILIARY POWER TO START ENGINE - CONTINUED

STEP	PROCEDURE	FIG/ITEM
<b>USING AUXILIARY POWER TO START ENGINE - Continued</b>		
2	Start auxiliary vehicle engine or auxiliary generator and adjust throttle. When using M551 vehicle for auxiliary power (slave starting source) adjust throttle control knob to indicate 1300 to 1500 RPM on tachometer indicator prior to cranking stalled vehicle. Do not accelerate engine during slave start. Engine speed will decrease and battery-generator indicator will normally drop into yellow or red band during slave starting.	
3	Press stalled vehicle ENGINE STARTER switch to start engine. Follow applicable starting procedure (table 2-3, or figure 2-14 and table 2-4. 1).	
4	Increase engine rpm in receiving vehicle when engine has started.	
5	Disconnect auxiliary power cable and quickly turn on vehicle MASTER SWITCH.	



1. ASSEMBLE TOWING CABLES TO SHACKLES
2. CONNECT SHACKLES TO VEHICLE TOWING LUGS WITH HEADED PIN AND SECURE WITH RETAINING PIN.

**WARNING:** CHECK BRAKING CAPABILITY OF TOWED VEHICLE BEFORE TOWING WITH CABLES.

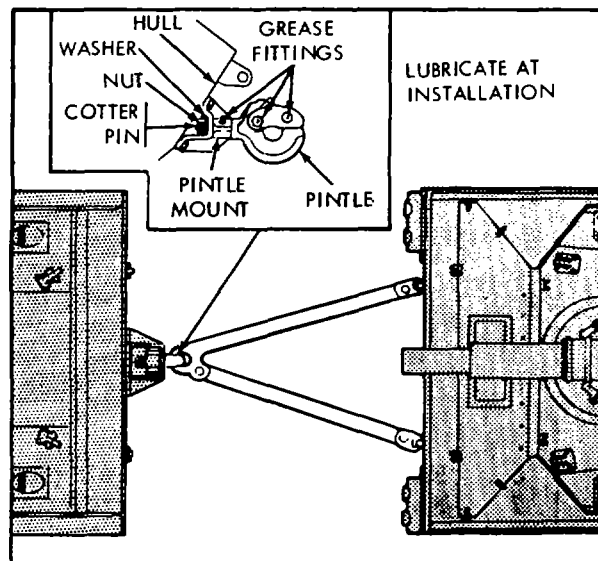

1. REMOVE COTTER PIN, NUT, AND WASHER, AND REMOVE TOW PINTLE FROM STOWAGE LOCATION ON TURRET.
2. INSTALL PINTLE IN MOUNT WITH WASHER, AND SECURE WITH NUT AND COTTER PIN.
3. CONNECT TOW BAR TO PINTLE OF TOWING VEHICLE AND TO TOW LUGS OF TOWED VEHICLE.
4. AFTER TOWING, REMOVE AND STOW PINTLE.

WE 12189

Figure 2-15. Installation of tow shackles, tow pintle, tow cables or tow bar

## Section 2-3. OPERATION OF AUXILIARY EQUIPMENT

## 2-4. Operation Instructions

The following tables and illustrations provide auxiliary equipment operating instructions.

TABLE 2-6. OPERATION OF MBA3 AIR FILTER UNIT

STEP	PROCEDURE	FIG/ITEM
<b>BEFORE OPERATION</b>		
<p><b>NOTE.</b> <u>The MBA3 air filter unit is used in connection with a tank protective mask for protection against toxic gases and in extremely dusty conditions to remove dust from air breathed by crew members.</u></p>		
<p><b>WARNING:</b> 1. <u>In toxic gas attack, don mask immediately before beginning operation of filter unit.</u></p>		
<p>2. <u>The air filter unit will not protect user against carbon monoxide.</u></p>		
<p>3. <u>Do not supply air from filter unit to masks when vehicle interior is below +20 degrees. Injury to user's lungs may result.</u></p>		
1	Perform before-operation preventive-maintenance checks and services (table 4-1, step 43).	
2	Unstrap carriers from stowed positions and remove masks. 2-16/1,2	
3	Don masks and adjust face pieces.	
4	Remove commander's, gunner's, and loader's air purifier-to-canister hoses from stowage bag. 2-16/4	
5	Remove driver's air purifier-to-canister hose from spring clips and connect to canister. 2-16/8,9	
<p><b>NOTE.</b> <u>If the air filter unit is to be used by fewer than four persons, disconnect the unused hose from the air purifier. Cover the unused outlet or outlets on the air purifier with air flow control caps. When only three outlets are used, the fourth outlet is covered with an air-flow control cap without a center hole. When less than three outlets are used, one of the holes is covered with an airflow control cap without a center hole and the other outlets are covered with airflow control caps with center holes.</u></p>		
6	Remove spring clip from air purifier housing.	2-16/12
7	Remove caps from air purifier and connect commander's, gunner's, and loader's air purifier-to-canister hoses. 2-16/11	2-16/11
8	Turn on air filter unit with rheostat knob located on loader's control box, and increase to maximum airflow. If excessive airflow around face piece causes discomfort, reduce the flow accordingly with rheostat knob. 3-1/A	
<b>AFTER OPERATION</b>		
9	Remove masks, place in carriers and stow.	2-16/1,5
10	Turn air filter unit COMPLETELY OFF (rheostat knob counterclockwise).	3-1/A
11	Uncouple commander's, gunner's, and loader's air purifier-to-canister hoses and place in stowage bag. 2-16/4, 6	2-16/4, 6

TABLE 2-6. OPERATION OF M8A3 AIR FILTER UNIT - CONTINUED

STEP	PROCEDURE				FIG/ITEM	
12 13	<b>AFTER OPERATION- Continued</b>				2-16/8, 9 2-16/12	
	Stow driver's air purifier-to-canister hose in spring clips. Fasten spring clip over holes in air purifier housing.					
<b>PROTECTIVE LIFE OF GAS FILTERS</b>						
Record the duration of each chemical attack and the type of agent used. With this record, the protective life of the M12A1 gas filter can be computed using the following information. The operator will notify organizational maintenance personnel to replace the gas filter when 100 replacement units have been used.						
<b>GAS FILTER REPLACEMENT UNITS</b>						
Type Of Attack						
Duration of attack (min)	Ground-delivered nerve agents (units used)	Each air delivered nerve agent attack and all blister agent attacks except CX (units used)	CX and all other agents including CK (units used)	unidentified agents (units used)		
2	1/2	1	10	6		
4	1	2	20	12		
6	1-1/2	3	30	18		
8	2	4	40	24		
10	2-1/2	5	50	30		
12	3	6	60	36		
14	3-1/2	7	70	42		
16	4	8	80	48		
18	4-1/2	9	90	54		
20	5	10	100	60		
An attack lasting less than 2 minutes is considered to have a duration of 2 minutes. An attack lasting longer than 2 minutes but less than 4 minutes is considered to have a duration of 4 minutes. Similar consideration is given to attacks up to 20 minutes.						
To calculate the number of units used in an attack longer than 20 minutes, the following formula may be used: Multiply the duration (number of minutes) by the number of units shown on line 1 of the appropriate attack column and divide by 2. For example, a filter exposed to a 30-minute air-delivered nerve agent attack would use 15 replacement units, as follows:						
$\frac{30 \text{ minutes} \times 1 \text{ unit}}{2} = 15 \text{ units}$						
<b>2-25</b>						



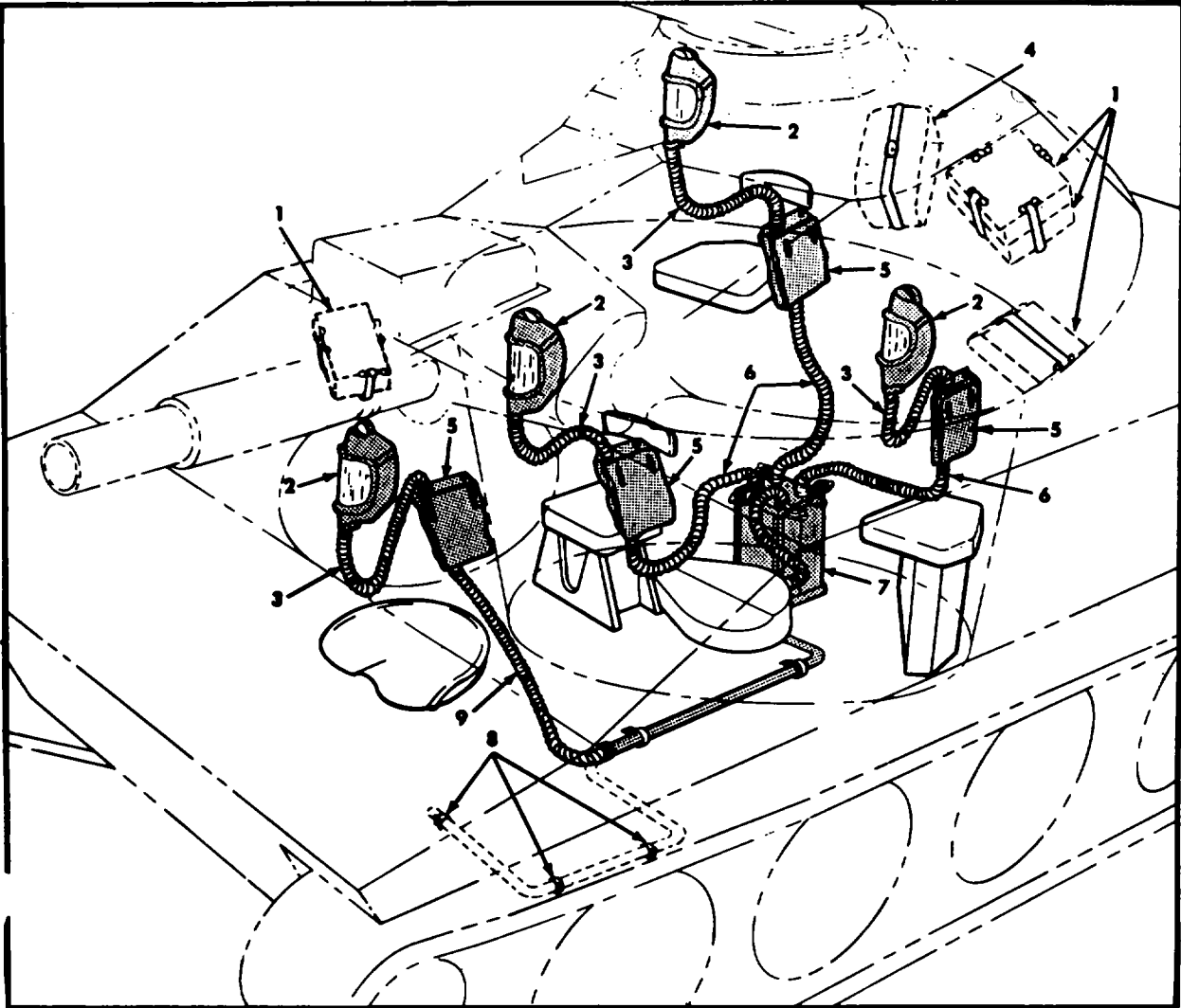

- 1. CARRIER WITH PROTECTIVE MASK AND CANISTER (STOWED POSITION).
- 2. M25 OR M25A1 TANK PROTECTIVE MASK.
- 3. CANISTER TO MASK HOSE.
- 4. COMMANDER'S, GUNNER'S AND LOADER'S CANISTER-TO-AIR PURIFIER HOSE STOWAGE BAG.
- 5. CARRIER WITH CANISTER.
- 6. CANISTER-TO-AIR PURIFIER HOSE .
- 7. AIR PURIFIER.
- 8. DRIVER'S CANISTER-TO-AIR PURIFIER HOSE STOWAGE CLIPS.
- 9. DRIVER'S CANISTER-TO-AIR PURIFIER HOSE.

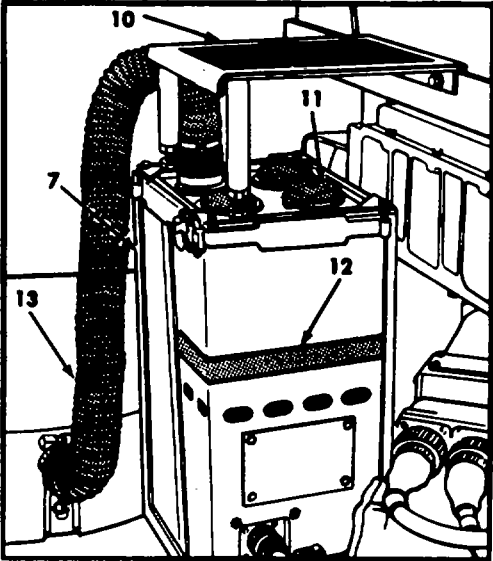

WE 10925

Figure 2-16. M8A3 air filter unit

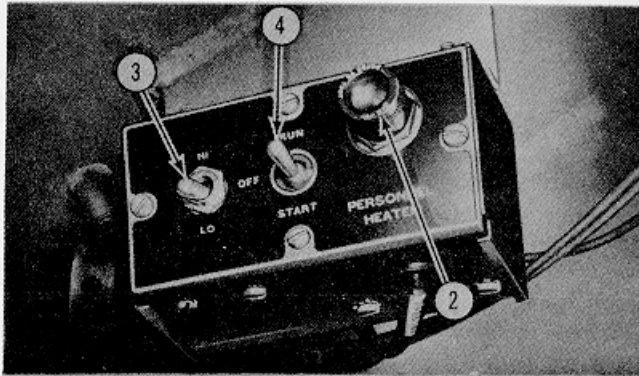

PERSONNEL HEATER CONTROL BOX

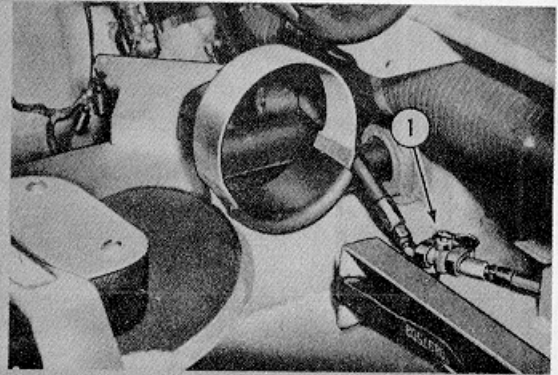

HEATER FUEL SUPPLY VALVE

STEP	PROCEDURE
STARTING PROCEDURE - PERSONNEL HEATER ONLY	
1	MAKE SURE HEATER FUEL SUPPLY VALVE IS OPENED BEFORE STARTING HEATER (VALVE HANDLE PARALLEL TO VALVE AND FUEL LINE).
	<b>NOTE.</b> HEATER MAY BE OPERATED WITH MASTER SWITCH (FIG. 2-10) ON OR OFF.
2	DEPRESS INDICATOR LIGHT. LAMP WILL ILLUMINATE.
	<b>NOTE.</b> IF INDICATOR LAMP DOES NOT ILLUMINATE, REPLACE LAMP AND/OR DETERMINE CAUSE FOR LACK OF ELECTRICAL CONTINUITY.
3	PLACE HEAT SELECTOR SWITCH TO "HI" OR "LO" POSITION.
4	HOLD HEATER CONTROL SWITCH IN "START" POSITION FOR APPROXIMATELY NINETY SECONDS (LONGER IN EXTREMELY COLD WEATHER) UNTIL INDICATOR LAMP ILLUMINATES.
5	SNAP HEATER CONTROL SWITCH (ITEM 4) TO "RUN" POSITION.
STOPPING HEATER	
6	PLACE HEATER CONTROL SWITCH TO CENTER "OFF" POSITION. INDICATOR LAMP WILL REMAIN ILLUMINATED AND BLOWER WILL CONTINUE TO RUN FOR 2 OR 3 MINUTES UNTIL THE COMBUSTION CHAMBER HAS BEEN PURGED.

NOTE. FOR OPERATION OF WINTERIZATION KIT COOLANT HEATER, REFER TO TABLE 2-13.

WE 11249A I

Figure 2-17. Operation of personnel heater

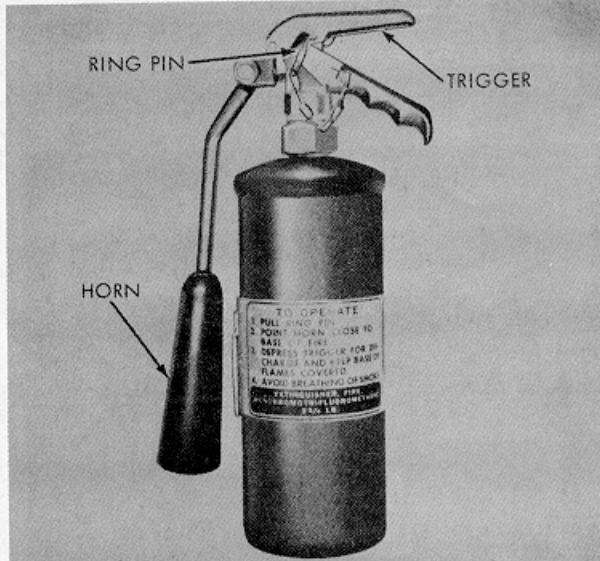

A. PORTABLE FIRE EXTINGUISHER.

OPERATION - PORTABLE FIRE EXTINGUISHER

1. PULL RING PIN.
2. POINT HORN CLOSE TO BASE OF FIRE.
3. DEPRESS TRIGGER FOR DISCHARGE, AND KEEP BASE OF FLAMES COVERED.
4. AVOID BREATHING OF SMOKE.

CREW COMPARTMENT AND FIXED FIRE EXTINGUISHERS

**WARNING:** CREW MUST NOT REMAIN IN VEHICLE AFTER EXTINGUISHER(S) ARE ACTUATED.

INTERIOR ACTUATING HANDLE (AT DRIVER'S STATION, C, FIG. 2-6) ACTUATES BOTH ENGINE COMPARTMENT AND CREW COMPARTMENT FIRE EXTINGUISHERS, AND AUTOMATICALLY SHUTS OFF FUEL TO ENGINE.

EXTERIOR ACTUATOR (20, FIG. 1-1) ACTUATES BOTH ENGINE AND CREW COMPARTMENT FIRE EXTINGUISHERS, BUT DOES NOT SHUT OFF FUEL TO ENGINE.

ELECTRICAL SWITCH (AT COMMANDER'S STATION, VIEW B) OPERATES CREW COMPARTMENT FIRE EXTINGUISHER ONLY.

ENGINE COMPARTMENT (FIXED) FIRE EXTINGUISHER CANNOT BE ACTUATED WITHOUT ALSO ACTUATING CREW COMPARTMENT EXTINGUISHER.

OPERATING PROCEDURE

1. PREPARE TO EVACUATE VEHICLE IMMEDIATELY.
2. REDUCE ENGINE SPEED TO IDLE AND SHUT OFF FUEL TO ENGINE.
3. ACTUATE CREW COMPARTMENT EXTINGUISHER (ELECTRICALLY), OR BOTH EXTINGUISHERS (BY EXTERIOR OR INTERIOR HANDLE).

NOTIFY ORGANIZATIONAL MAINTENANCE IF ANY FIRE EXTINGUISHER HAS BEEN OPERATED, OF IF SEAL WIRE IS BROKEN ON EITHER BOTTLE. REPLACEMENT MUST BE MADE AND VEHICLE INSPECTED BEFORE RETURN TO SERVICE. SEE VIEWS C AND D.

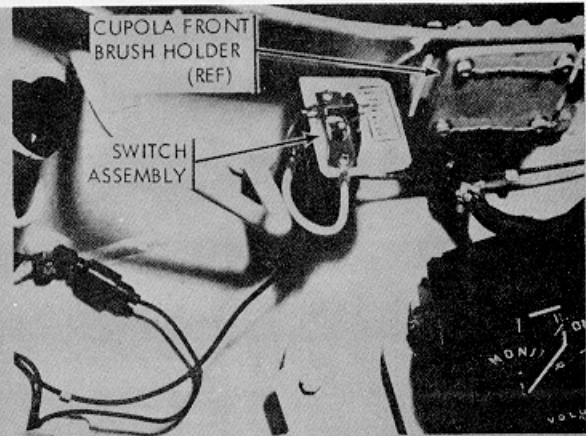

B. ELECTRICAL SWITCH - CREW COMPARTMENT FIRE EXTINGUISHER.

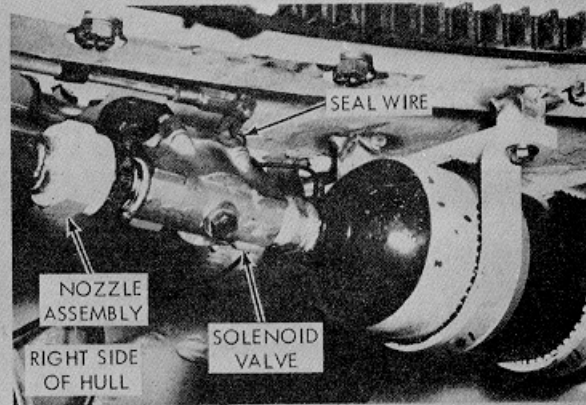

C. CREW COMPARTMENT FIRE EXTINGUISHER VALVE AND SOLENOID.

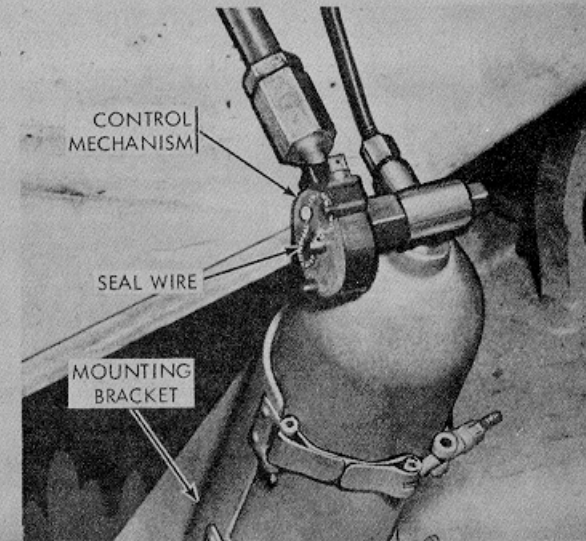

D. FIXED FIRE EXTINGUISHER CONTROL MECHANISM.

WE 66678

Figure 2-18. Operation of portable, fixed (engine compartment), and crew compartment fire extinguishers

**Section 2-4. OPERATION OF TURRET AND CUPOLA**

**2-5. Turret and Cupola Operation Instructions**

a. General. The following tables and illustrations provide turret and cupola operating instructions.

**NOTE.** Before operation, the crew should be familiar with the location and operation of all controls and instruments (figs. 2-19 through 2-22).

b. Electric Drive Control System. The electric drive control system provides controlled power for traversing the turret and elevating and depressing the weapon in either nonstabilized or stabilized modes. An electrical interlock is provided in the turret control switch circuit to prevent accidental operation of turret and weapon. If TURRET CONTROL POWER switch has been turned on prior to vehicle MASTER SWITCH, the system will not function until the TURRET CONTROL POWER switch is turned off and then on again. The gun-launcher can be elevated to 336 mils (19 degrees). Depression is limited to 142 mils (8 degrees) over the front and sides of vehicle and 56.8 mils depression over rear deck. When power traversing the turret and gun-launcher is below 58.8 mils depression, the gun-launcher will automatically elevate to clear the rear deck.

**CAUTION:** To prevent damage to electric drive system, do not hold control handle in maximum elevation or depression position when gun-launcher contacts mechanical stop. In manual traverse, the turret will contact a

mechanical, stop at rear deck. To continue traversing, elevate the gun-launcher to clear the stop.

c. Non-Stabilized Mode. When vehicle MASTER SWITCH and TURRET CONTROL POWER switch are turned on, the electric drive control system is in non-stabilized mode. When either gunner's or commander's control handle palm switch is depressed, the weapon and turret will respond to deflection of the control handle and elevate, depress, or traverse at a rate dependent on degree of deflection.

d. Stabilized Mode. When vehicle MASTER SWITCH, TURRET CONTROL POWER and STAB switches are turned on and with either control handle palm switch depressed, the electric drive control system is in stabilized mode and immediately becomes oriented in space at a fixed elevation and traverse attitude with vehicle moving over rough terrain. The gunner must still aim, track, and fire using traversing and elevating controls in usual manner, but has an advantage in that he is effectively firing from a stable space platform relatively undisturbed by vehicle pitch and roll. The weapon and sight will remain stabilized in space as long as gunner's or commander's palm switch is depressed. The control handles will move the weapon and turret at precisely controlled rates as in non-stabilized mode. When control handles are centered, weapon and turret will again become oriented at elevation and traverse attitude relative to space that exists when the controls are neutralized.

TABLE 2-7. OPERATION OF TURRET

STEP	PROCEDURE	FIG/ITEM
<b>BEFORE OPERATION</b>		
1	Perform before-operation preventive-maintenance checks and services (table 4-1, steps 20 and 31 through 44).	
2	Make certain all personnel are clear of turret. Engine compartment grilles, and battery and air cleaner access doors and covers must be closed.	1-2/3, 5, 6, 16
3	Release turret traverse lock.	2-20/C
4	Turn vehicle MASTER SWITCH on, and start engine. Engine must be operating at 750 RPM to maintain voltage during operation. 2-10	

TABLE 2-7. OPERATION OF TURRET - Continued

STEP	PROCEDURE	FIG/ITEM
	<b>BEFORE OPERATION - Continued</b>	
	<b>CAUTION:</b> <u>To enter driver's compartment by way of open space between air compressor and rear air bottle, manually traverse turret so gun launcher is positioned over rear deck. This method of entry prevents damage to stowed ammo in racks under gun/launcher.</u>	
	<b>NOTE.</b> <u>Vehicle MASTER SWITCH must also be on when auxiliary power is supplied to operate turret.</u>	
5	Make sure TURRET CONTROL POWER and STAB switches are off and FIRE CONTROL selector is in OFF position.	2-19
	<b>MANUAL OPERATION</b>	
6	Depress adjustment lever and move gunner's power control handle to lowered position.	2-19
7	Release manual elevation handwheel by pulling up locking pin and elevate or depress gun-launcher.	2-19
8	Traverse turret with manual traverse handle.	2-19
	<b>ELECTRICAL OPERATION (NON-STABILIZED MODE)</b>	
6A	Secure manual elevation handwheel by engaging locking pin in retainer. Depress adjustment lever and move gunner's power control handle to raised position.	2-19
7A	Turn TURRET CONTROL POWER switch on. The indicator lamp above the switch will illuminate.	2-19
	<b>NOTE.</b> <u>Allow approximately 20 seconds until TURRET CONTROL POWER switch READY lamp illuminates.</u>	2-19
8A	Depress palm switch on power control handle and remove any gun elevation or turret azimuth drift by rotating TRAV and/or ELEV trim buttons. Rotate gunner's control handle to elevate or depress gun and to traverse turret onto target.	2-19 and 2-21/7, 8, 11
	<b>CAUTION:</b> <u>DO NOT KEEP HANDLE IN ELEVATION OR DEPRESSION POSITION WHEN MECHANICAL STOP IS REACHED. Immediately return handle to neutral position or back away from stop. A stalled servo motor (recognizable by high pitched sound, and/or burning odor from motor generator) will cause severe damage to servo motor and motor generator.</u>	
	<b>NOTE.</b> <u>Commander can override gunner's control in either non-stabilized or stabilized modes by depressing his palm switch and rotating control handle.</u>	2-21/6, 11

TABLE 2-7. OPERATION OF TURRET - Continued

STEP	PROCEDURE	FIG/ITEM
<b>ELECTRICAL OPERATION (STABILIZED MODE)</b>		
6B	Follow steps 6A through 8A above.	
7B	Turn TURRET CONTROL STAB switch on. The indicator lamp will illuminate.	2-19
8B	Continue squeezing gunner's control handle palm switch. Gun-launcher will automatically remain parallel to initial line of sight in elevation and azimuth while tracking vehicle is moving.  <u><b>NOTE.</b> Gunner must make corrections in elevation due to the rise or fall of terrain and azimuth corrections due to vehicle horizontal movement.</u>	2-19
<b>AFTER OPERATION</b>		
9	Turn TURRET CONTROL STAB and POWER switches off. Indicator lamps will go out.	2-19
10	Secure turret traverse lock.	2-20/C
11	Perform after-operation preventive-maintenance checks and services, table 4-1, steps 101 and 109 through 118).	



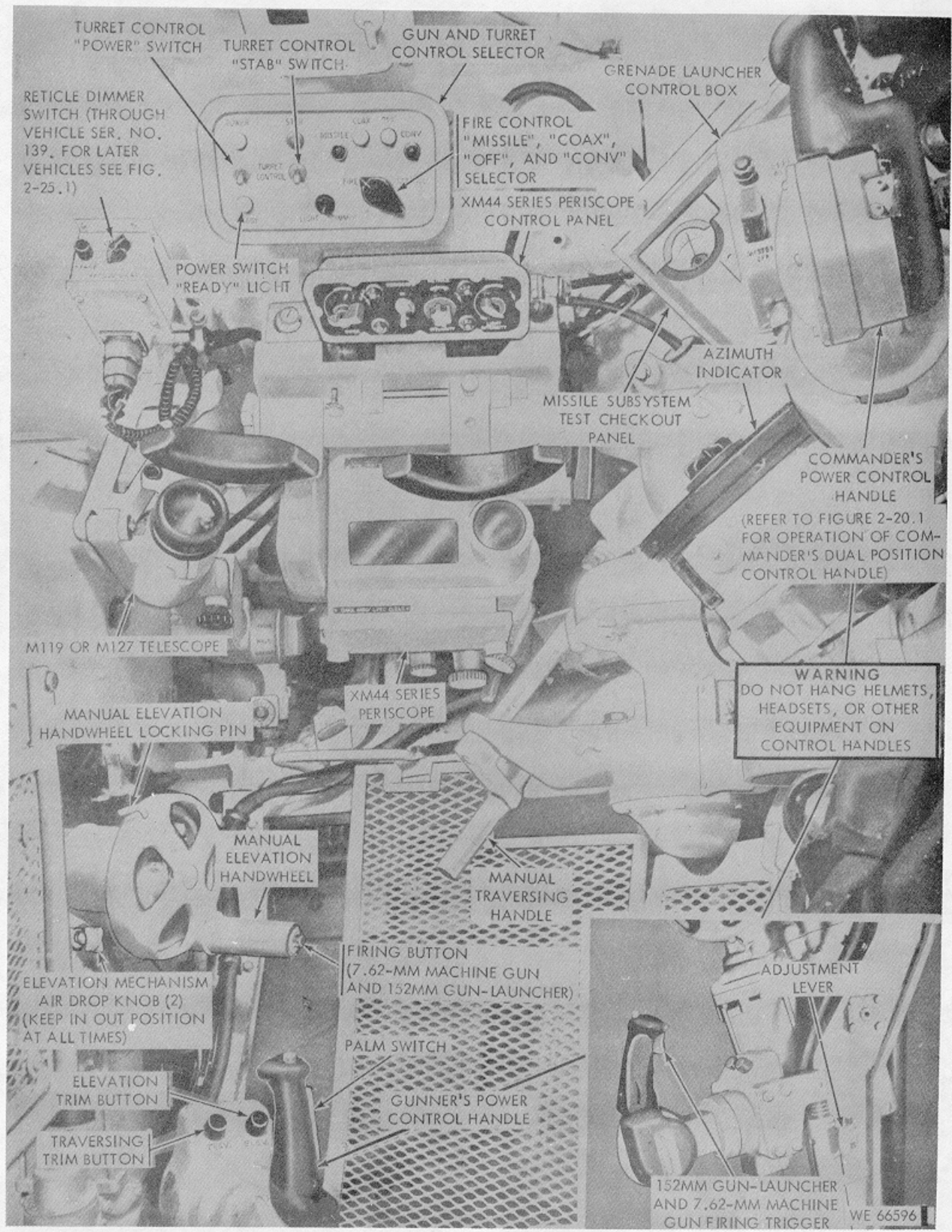

Figure 2-19. Gunner's controls and instruments

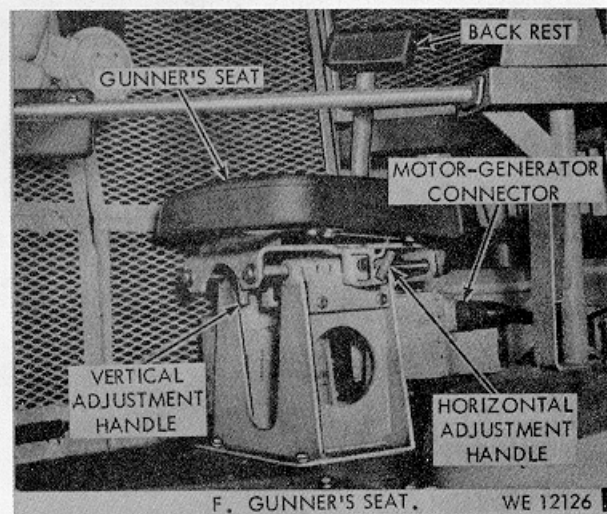
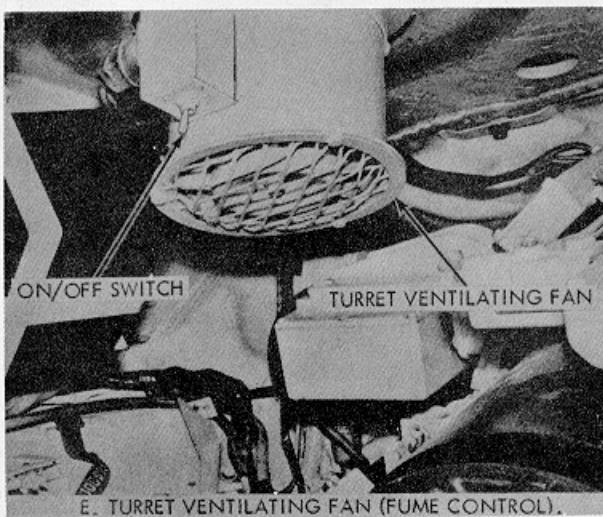
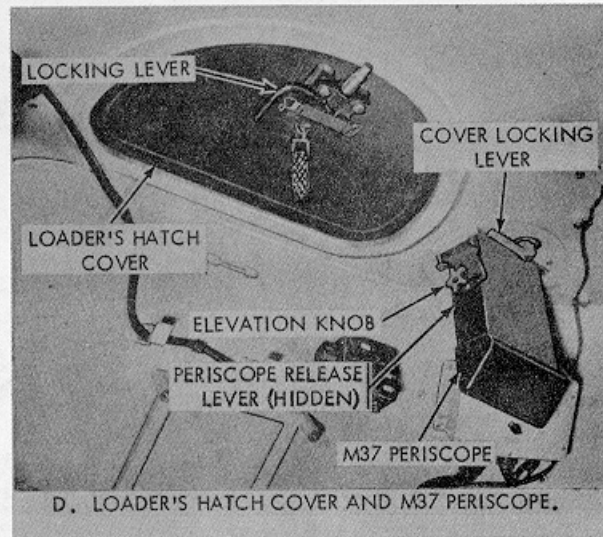
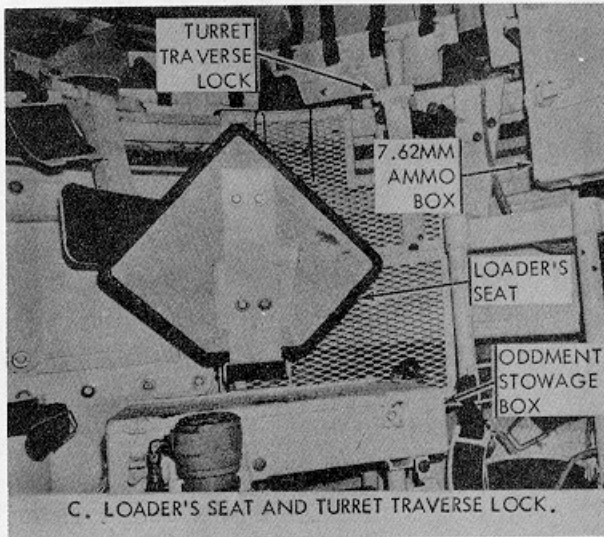
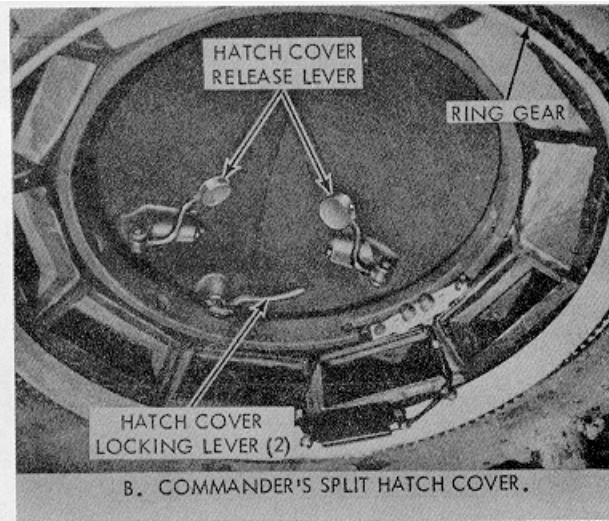
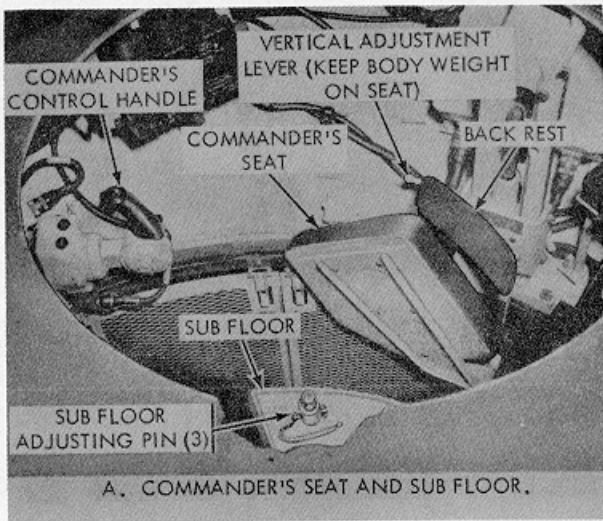

Figure 2-20. Turret miscellaneous controls (through vehicle S/N 699)



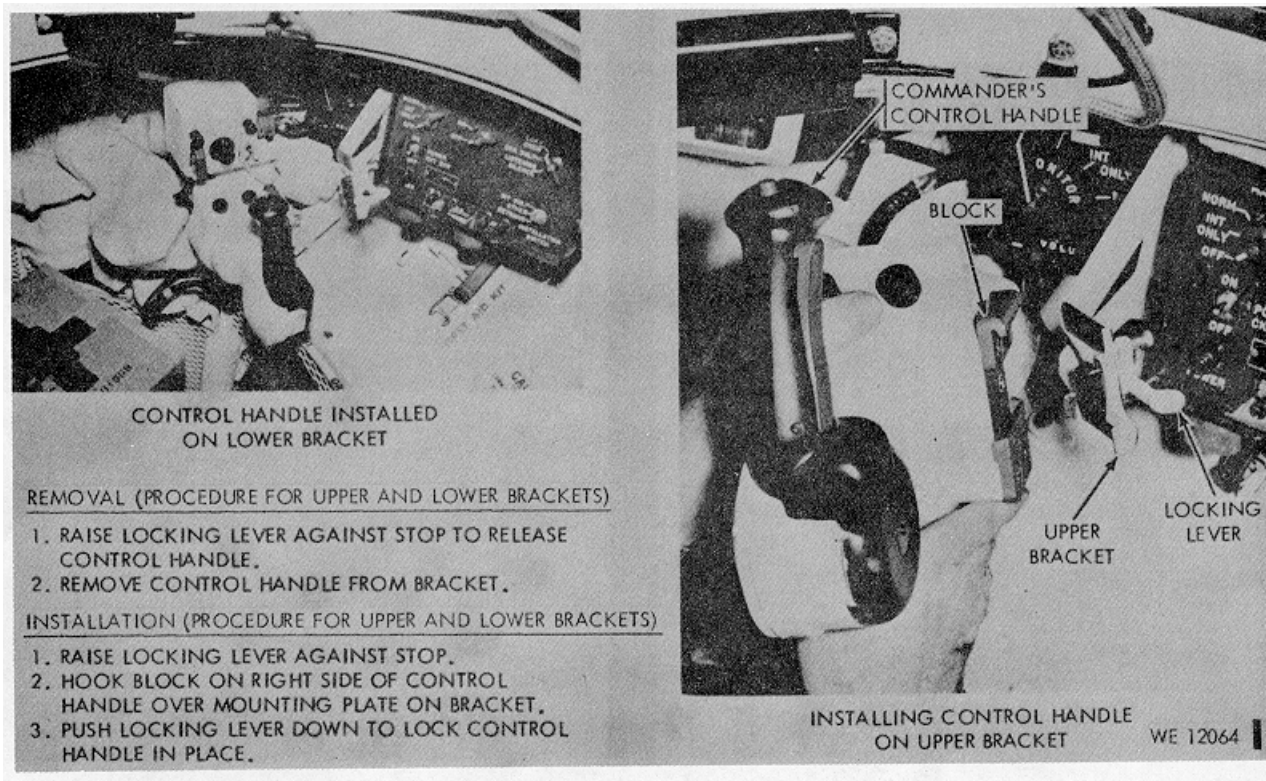

Figure 2-20.1. Dual position mounting of commander's control handle.

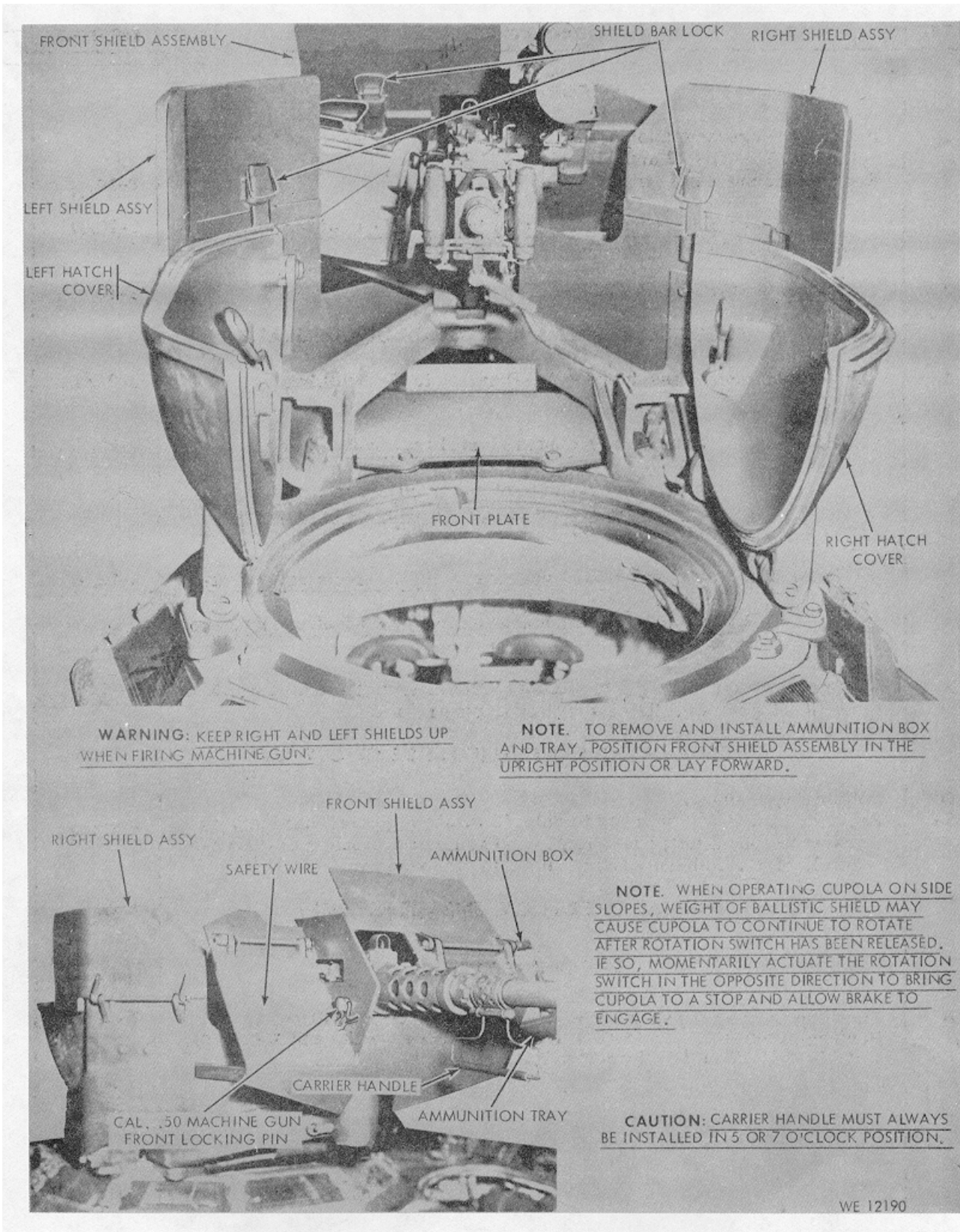
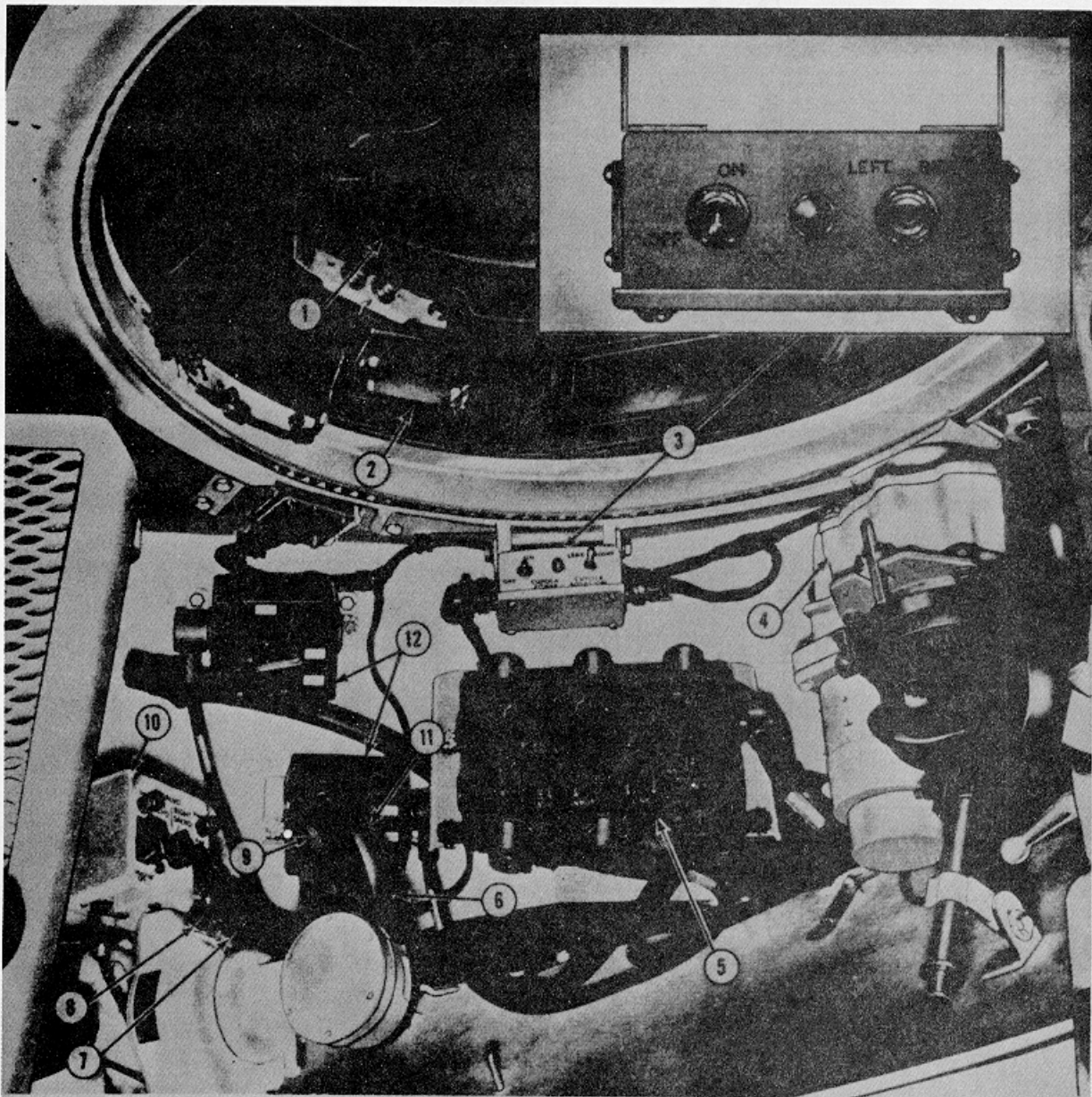

Figure 2-20.2. Commander's ballistic shield plate assemblies

TABLE 2-8. OPERATION OF CUPOLA

STEP	PROCEDURE	FIG/ITEM
	<b>BEFORE OPERATION</b>	
1	Perform before-operation preventive-maintenance checks and services (table 4-1, steps 29 and 30).	
2	Engage machine gun in travel lock. <b>WARNING:</b> <u>Make certain all personnel are clear of turret roof and loader's hatch cover is secured open or closed.</u>	3-14 2-20/D
3	Turn vehicle MASTER SWITCH on.	2-10
	<b>ELECTRICAL OPERATION (INSIDE OF CUPOLA)</b>	
4	Turn cupola control assembly POWER switch to ON position.  <b>CAUTION:</b> 1. <u>Make certain cupola manual traverse handle is down in stowed position clip.</u> 2. <u>Maximum operation of power cupola is 2 minutes on and 10 minutes off to prevent damage to traverse motor.</u>  <b>NOTE.</b> 1. <u>Safety switch will not permit cupola electrical operation with cupola manual traverse handle engaged.</u> 2. <u>Cupola brake is automatically released when operating cupola electrically.</u>	2-21/3  2-22/1  2-22/B
5	Press cupola control assembly ROTATION switch to the traverse LEFT or RIGHT position. Release switch to stop rotation.	2-21/3
	<b>ELECTRICAL OPERATION (OUTSIDE OF CUPOLA)</b>	
4A	Follow step 4 above.	
5A	Press control button attached to cal. .50 machine gun left-hand grip to traverse cupola left; press right-hand grip control button to traverse cupola right. Release control button to stop rotation.	2-4
	<b>MANUAL OPERATION (EMERGENCY USE) 2-22</b>	
	<b>AFTER OPERATION</b>	
6	Turn cupola control assembly POWER switch to OFF position.	2-21/3
7	Perform after-operation preventive-maintenance checks and services, (table 4-1, steps 106 through 108).	
	<b>2-33</b>	



- |  |   |
|--|---|
| 1. SPLIT HATCH COVER                               | 7. ELEVATION TRIM BUTTON  |
| 2. VISION BLOCK (10)                               | 8. TRAVERSING TRIM BUTTON                                       |
| 3. CUPOLA CONTROL ASSEMBLY                         | 9. 152MM GUN-LAUNCHER AND 7.62-MM<br>MACHINE GUN FIRING TRIGGER |
| 4. CUPOLA TRAVERSE MECHANISM                       | 10. GRENADE PROJECTOR CONTROL PANEL                             |
| 5. AM-1780/VRC AUDIO FREQUENCY AMPLIFIER           | 11. PALM SWITCH   |
| 6. TURRET AND GUN-LAUNCHER POWER<br>CONTROL HANDLE | 12. C-2298/VRC INTERCOM SET CONTROL                             |

WE 10909

Figure 2-21. Commander's power assist cupola controls



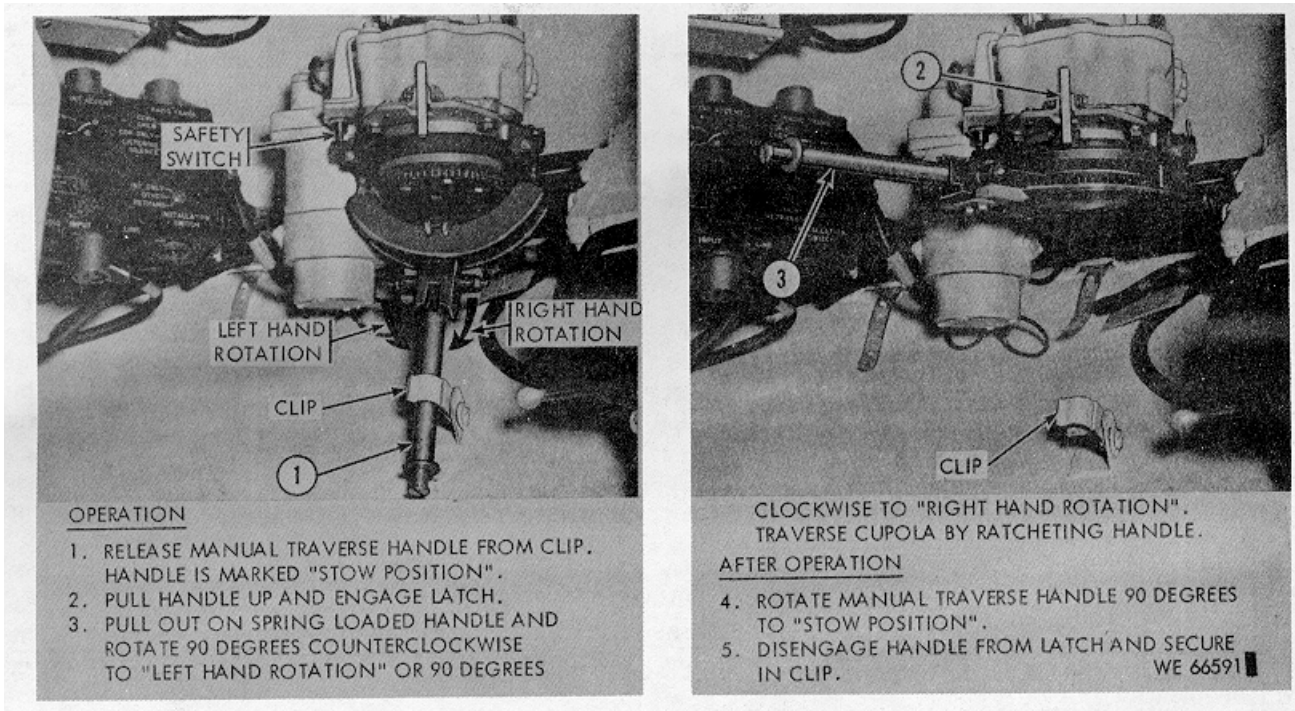

Figure 2-22. Manual operation of commander's power assist cupola

## Section 2-5. OPERATION OF SIGHTING AND FIRE CONTROL AND ARMAMENT BORESIGHT PROCEDURE

### 2-6. Operation Instructions.

**a. General.** The following tables and illustrations provide sighting and fire control operating and armament boresight instructions.

**NOTE.** Before operation the crew should be familiarized with the location and operation of all controls and instruments (figs. 2-23 through 2-29).

**b. M119 or M127 Telescope.** The telescope, with associated M149 mount and checksight, is a primary fire control instrument employed by the gunner. The M127 is similar to the M119 in design and operation, with the additional feature of dual (8 or 12) power magnification. A selector lever, mounted on right side of telescope, provides 12X magnification when positioned toward operator. (Advantage: Provides gunner with choice of magnification when viewing targets for either conventional or missile round. ) The M127 will replace the M119 in all M551 vehicles.

The telescope is a hermetically sealed direct fire control instrument for conventional ammunition, and, with a associated tracker, is also part of the missile subsystem. The telescope, attached to the mount, is mounted coaxially with the 152MM gun -launcher and embodies

an articulated joint so that the eyepiece is made conveniently available to the gunner throughout the range of gun elevation and depression. A dioptal adjustment is provided to accommodate focal variations between individual observers. A field (user) parallax correction adjustment for the telescope and the mount is also incorporated. Two separate reticle patterns, one for the conventional round and one for the guided missile, may be presented separately in the field of view by means of optical projection. Selection of reticles is made by actuating a switch, while illumination intensity of either the conventional ammunition or the missile pattern is controlled by a rheostat on the gunner's reticle dimmer box. Accurate boresight retention is ensured when the patterns are interchanged because no physical movement of parts is required. Associated equipment necessary for proper installation and operation of the M119 or M127 Telescope consists of:

- (1) **M149 Telescope Mount.** The mount supports the missile tracker which is part of the missile subsystem. A checksight mounted on the left side of the assembly is used for optical alignment of the missile tracker and the telescope.

- (2) Checksight. The checksight is an opto-mechanical device for checking the alignment of the tracker and telescope with respect to each other, and to check the proper functioning of the missile tracker. The checksight is mounted in a cavity on the left side of the M149 Mount.
- (3) Tracker. The tracker is the eye of the missile subsystem and monitors the missile in flight with the line of sight.

c. XM44 Series Gunner's Periscope.

**NOTE.** The XM44 Periscope, together with the later design XM44E1 and XM44E2, comprise the "XM44 Series". In this manual, models are differentiated as follows: "XM44 Series" all "XM44E Series" all except XM44 "XM44" XM44 only.

These periscopes are all interchangeable as complete units, but major assemblies (i. e. head

and body) are not interchangeable between XM44 and XM44E Series. Except where specifically indicated otherwise, operation and maintenance procedures are identical for all models.

Periscope (fig. 2-26) is a major component of the fire control system and serves as the primary "night" fire-control instrument. The Periscope consists of two major assemblies, the head assembly and the body assembly. The head assembly provides a large entrance aperture and the means for elevating and depressing the field of view. The body assembly houses a large aperture optical system to pass as much of the available light as possible, an image intensifier tube, an optical system to view the tube screen, a reticle projector system to superimpose a ballistic reticle pattern on the target image, and the unity power optical system for direct "day" viewing.

d. Individual Weapons Night Vision Sight. The Individual Weapons Night Vision Sight (fig. 2-29) is a battery-powered, electro-optical device for visual observation and aimed fire at night under ambient sky light for the cal. .50 machine gun, M2, HB and also can be used as a hand-held surveillance device. The sight offers maximum freedom from the possibility of enemy detection.

TABLE 2-9. OPERATION OF M119 OR M127 TELESCOPE, XM44 SERIES PERISCOPE, AND ARMAMENT BORESIGHT PROCEDURE

STEP	PROCEDURE	FIG/ITEM
<b>ALIGNING GUN-LAUNCHER AND 7.62MM MACHINE GUN</b>		
1	Position vehicle on level ground.	
2	Secure muzzle boresight (black thread) in reference marks on gun 2-23/A muzzle with strap or tape.	
3	Open breech and insert breech boresight assembly.	2-23/B
4	Position right telescope of binocular M17A1 over hole of breech boresight assembly and select a distant aiming point at approximately 1200 meters with sharply defined vertical and horizontal lines. Align muzzle boresight cross hairs on aiming point by traversing and elevating weapon.	2-23/B
5	Align machine gun.	2-24
<b>OPERATING GUNNER'S M119 OR M127 TELESCOPE</b>		
6	Turn vehicle MASTER SWITCH on.	2-10
7	Turn FIRE CONTROL selector to CONV position. The corresponding lamp above the selector will illuminate.	2-19
8	Turn RETICLE LIGHT rheostat knob on reticle dimmer box clockwise for increased intensity of reticle lamp.	2-25/1 & 2-25.1/6
9	Adjust headrest to fit gunner.	2-25
10	Pull and turn diopter knob until proper focus is obtained.	2-52/2

TABLE 2-9. OPERATION OF M119 OR M127 TELESCOPE, XM44 SERIES PERISCOPE,  
AND ARMAMENT BORESIGHT PROCEDURE - Continued

STEP	PROCEDURE	FIG/ITEM
	<p><b>NOTE.</b> <u>Operation, parallax adjustments, and boresighting can be performed with the M127 Telescope in either of the two power (8X or 12X) positions.</u></p>	
11	<p style="text-align: center;"><b>PARALLAX ADJUSTMENTS - TELESCOPE M119 OR M127 AND MOUNT M149</b></p> <p>Parallax adjustment between the telescope M119 or M127 and mount M149 is a screwdriver adjustment and is accomplished as deemed necessary by the operator. The control is located on the upper side of the telescope above the filter selector lever. While observing a target at 1200 meters through the eyepiece, and the vertical reticle line adjacent to the target reference, move the head up and down and sideways. If the reticle marking of the target seems to move, adjust screw to obtain minimum parallax between the target and the reticle as the eye is moved back and forth across the eyepiece.</p>	2-25/15
	<p style="text-align: center;"><b>BORESIGHTING M119 OR M127 TELESCOPE CONV. RETICLE PATTERN,</b></p>	
12	Pull and turn elevation and azimuth knobs until conventional reticle is aligned with aiming point.	2-23/E and 2-25/7, 9
13	Slip scales on elevation and azimuth boresight knobs to position "1".	2-25/7, 9
	<p style="text-align: center;"><b>BORESIGHTING M119 OR M127 TELESCOPE MISSILE RETICLE PATTERS</b></p>	
14	Turn FIRE CONTROL selector to MISSILE position. The missile reticle will appear in the telescope.	2-19and 2-23/D
15	View through telescope but do not adjust.	2-25
	<p><b>NOTE.</b> <u>Distant aiming point (any portion) must align with upper square area of missile reticle pattern in telescope. If not, proceed with tracker alignment procedure (table 2-12, step 12) and recheck. If reticle is still not aligned, notify organizational maintenance personnel.</u></p>	
	<p style="text-align: center;"><b>OPERATING PROCEDURES FOR XM44 SERIES PERISCOPE</b></p>	
	<p><b>NOTE</b> <u>To be used when ambient light conditions do not permit use of telescope.</u></p>	
16	Close periscope unity power window cover.	2-26/12
	<p><b>NOTE.</b> <u>If the periscope is not equipped with a unity power window cover plate, place tape or other material over the unity power window to avoid backlighting the system.</u></p>	

TABLE 2-9. OPERATION OF M119 OR M127 TELESCOPE, XM44 SERIES PERISCOPE,  
AND ARMAMENT BORESIGHT PROCEDURE - Continued

STEP	PROCEDURE	FIG/ITEM
<b>OPERATING PROCEDURES FOR XM44 SERIES PERISCOPE Continued</b>		
17	Turn off or reduce intensity of all internal lights (dome lights, panel lights, etc. ). This will improve gunner's viewing ability.	
18	Place filter of periscope in the dark position.	2-26/21
19	Deleted.	
20	Open ballistic cover.	2-26/8, 9
21	Place periscope ON/OFF switch to the ON position. <b>NOTE.</b> <u>If a green flash of light is seen briefly and the image tube goes out, the exterior light level is too high for operating the periscope.</u>	2-26/ 6
22	Adjust headrest.	2-26/11
23	Select filter which provides the best lighting condition of the image tube without cutting it off.	2-26/21
24	Turn focusing knob-to infinity position (max. ccw).	2-26/23
25	Adjust reticle light intensity control clockwise for proper illumination of reticle pattern. Proper illumination is obtained when reticle is barely visible.	2-26/5
25.1	Slip boresight knobs to position "1".	
26	While observing reticle through eyepiece of periscope, pull out diopter knob and adjust setting until reticle appears with maximum sharpness.	2-26/22
27	Set periscope on a distant visible target. Rotate focusing knob until target is sharply defined. Re-adjust diopter setting if required. <b>NOTE 1.</b> <u>Focus must be adjusted for each change of target range.</u> <b>NOTE 2.</b> In the event vehicle power is lost, switch periscope ON/OFF switch to emergency power position. In the emergency position, the reticle should be used as little as possible to conserve battery power.	2-26/23
	<b>NOTE 3.</b> <u>Turn reticle pattern off for ultimate performance in scanning operation.</u>	2-26/6
28	When periscope is not in use: Turn periscope ON/OFF switch to OFF position.	2-26/6
29	Turn filter to DARK (XM44) or OFF (XM44E Series)	2-26/21
30	Close ballistic cover.	2-26/8, 9
<b>BORESIGHTING GUNNER'S XM44 SERIES PERISCOPE</b>		
<b>NOTE.</b> <u>XM44 Series periscopes are boresighted and zeroed at a distance of 1200 meters.</u>		
<b>CAUTION:</b> <u>Use periscope boresight aid (10516830) when boresighting in daylight. Use dark position filter to prevent excessive light from damaging internal components when boresighting or at all times when periscope is not in use.</u>		
31	Pull and turn elevation and azimuth boresight knobs until reticle is aligned with aiming point.	2-26/24, 26, and 2-23/F
32	Turn slip scales on elevation and azimuth boresight knobs to position "1".	2-26/24, 26



TABLE 2-9. OPERATION OF M119 OR M127 TELESCOPE, XM44 SERIES PERISCOPE,  
AND ARMAMENT BORESIGHT PROCEDURE - Continued

STEP	PROCEDURE	FIG/ITEM
<b>BORESIGHTING GUNNER'S XM44 SERIES PERISCOPE - Continued</b>		
<p><b>NOTE.</b> <u>If periscope can not be boresighted, refer to organizational maintenance personnel.</u></p>		
<b>AFTER OPERATING AND/OR BORESIGHTING</b>		
33	Remove breech boresight assembly and muzzle boresight.	2-23/A, B
34	Turn FIRE CONTROL selector to OFF position. Lamps will go out.	2-19
35	Turn RETICLE LIGHT INTENSITY knob fully counterclockwise and position filter selector to DARK (XM44) or OFF (XM44E Series). Leave selector in this position when periscope is not in use.	2-26/3, 21
36	Turn periscope ON/OFF switch to OFF position.  <b>CAUTION:</b> <u>Insure that boresight aid (10516830) is removed. Failure to comply could cause damage to the wiper assembly.</u>  <b>CAUTION:</b> <u>Make certain that periscope ON/OFF switch is in OFF position to prevent draining periscope battery.</u>	2-26/6
37	Close periscope ballistic cover.	2-26/8, 9
38	Turn MASTER SWITCH off.	

TABLE 2-9.1. ZEROING M119 OR M127 TELESCOPE AND XM44 SERIES PERISCOPE

STEP	PROCEDURE	FIG/ITEM
1	Perform procedures described in table 2-9, steps 1 through 32.	
2	Apply emergency zero to telescope by turning boresight knobs (CONV) to elevation "5" and azimuth "2".	2-25/7, 9
3	Select a well-defined point in the target area at a range of 1200 meters (use a 12 x 12 ft target when possible).	2-23
4	Select CONV on the gun and turret control selector.	2-19
5	Using the manual controls, lay the zeroing cross of the-telescope (1200 meters range line) on the aiming point.	2-19, 2-23
6	Fire a warmer round, followed by three rounds of the same lot number, to form a shot group. Re-lay the gun on the same aiming point after each round, using the manual controls.	2-19
7	When firing has been completed, re-lay the sight on the aiming point.	
8	Without disturbing the lay of the gun, using the telescope boresight knobs (CONV) move the zeroing cross (1200 meter range line) to the center of the shot group.	2-25/7, 9
9	Re-lay on the aiming point, using the manual controls and fire a check round. The projectile should strike within 24 inches of the aiming point. If it does not, fire a second check round. If either round strikes within the specified distance from the aiming point, the gun is zeroed. If not, the zeroing procedure is continued until a check round strikes within the prescribed distance.	2-19
10	With the gun-launcher zeroed, and using the manual controls, lay the telescope zeroing cross back on aiming point.	2-19
11	Using the boresight knobs on the periscope, move the reticle pattern 1200 meter range line to same aiming point as the telescope.	2-26/24, 26 2-23/F
12	A check round may be fired, using periscope to verify that the periscope is zeroed.	
13	Record zero setting of the telescope and periscope, and place in convenient part of the turret.	
14	Slip scales on telescope (CONV) and gunner's periscope boresight knobs to position "4".	

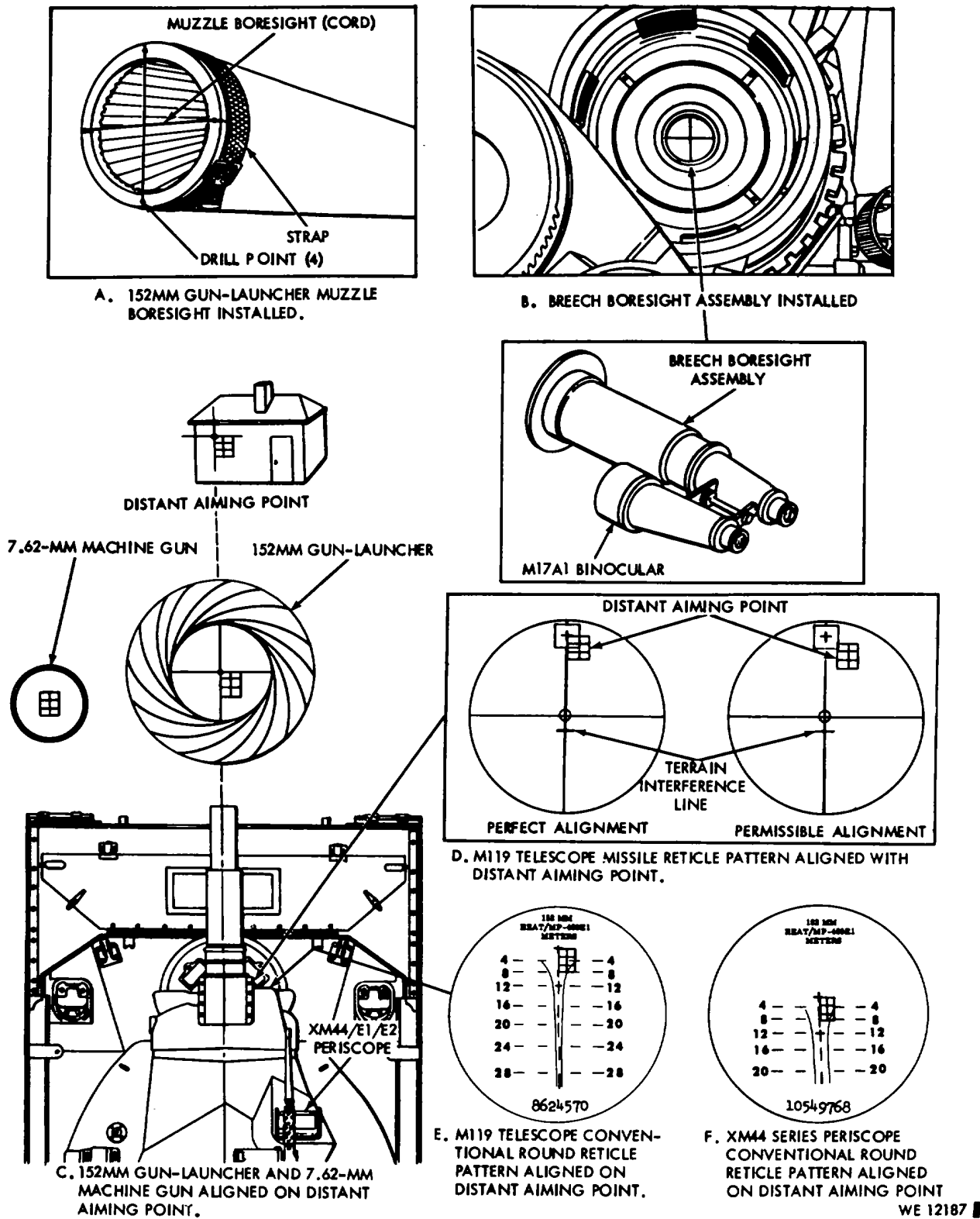
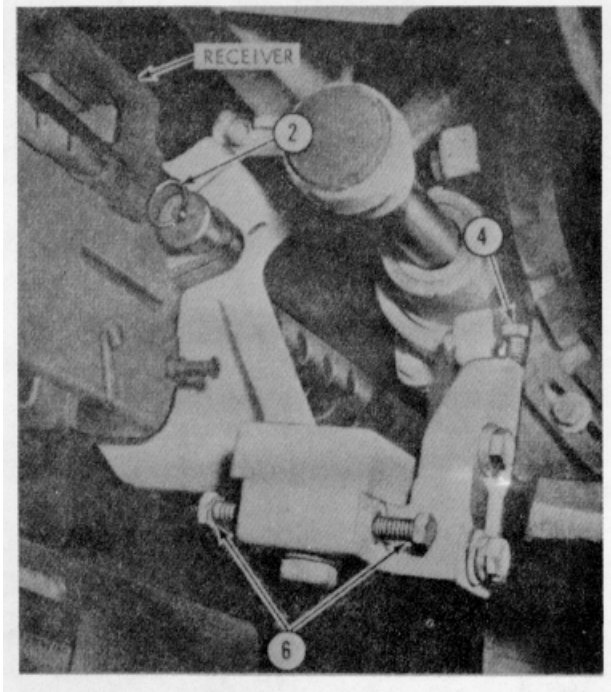
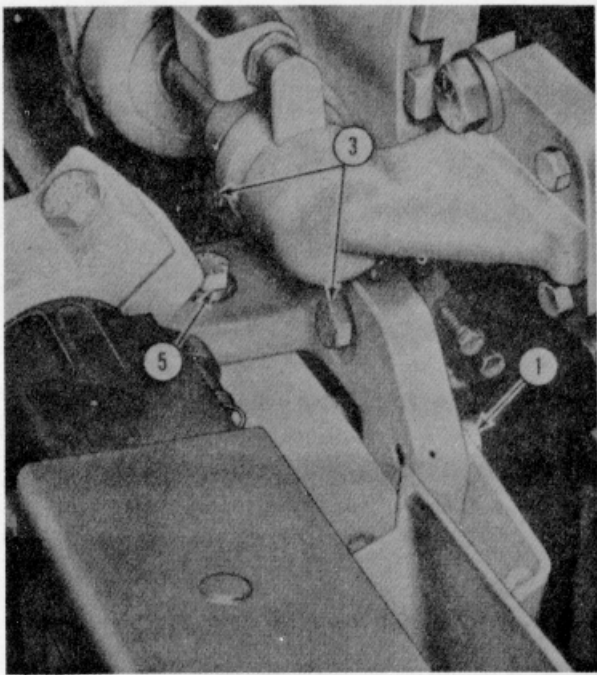

Figure 2-23. Weapons system boresighted on distant aiming point



#### ALIGNMENT PROCEDURE

1. REMOVE SPENT BRASS CHUTE EXTENSION (FIG. 3-7).
2. REMOVE 2 SCREWS AND WASHERS, REMOVE BRACKET WITH SPENT BRASS CHUTE AND BAG.
3. PULL REARWARD ON DISCONNECTOR RING, ROTATE RECEIVER CLOCKWISE AND REMOVE.
4. LOOSEN 2 MOUNTING SCREWS SLIGHTLY.
5. LOOK THROUGH BARREL AND LOOSEN UPPER OR LOWER ADJUSTING SCREW TO ALIGN BARREL IN ELEVATION WITH DISTANT AIMING POINT. TIGHTEN OPPOSITE ADJUSTING SCREW AND 2 MOUNTING SCREWS (ITEM 4).
6. LOOSEN 2 MOUNTING SCREWS SLIGHTLY.
7. LOOK THROUGH BARREL AND LOOSEN LEFT OR RIGHT ADJUSTING SCREW TO ALIGN BARREL IN AZIMUTH WITH DISTANT AIMING POINT. TIGHTEN OPPOSITE ADJUSTING SCREW AND 2 MOUNTING SCREWS (ITEM 6).
8. PULL REARWARD ON DISCONNECTOR RING (ITEM 3), ROTATE RECEIVER COUNTERCLOCKWISE AND INSTALL RECEIVER.

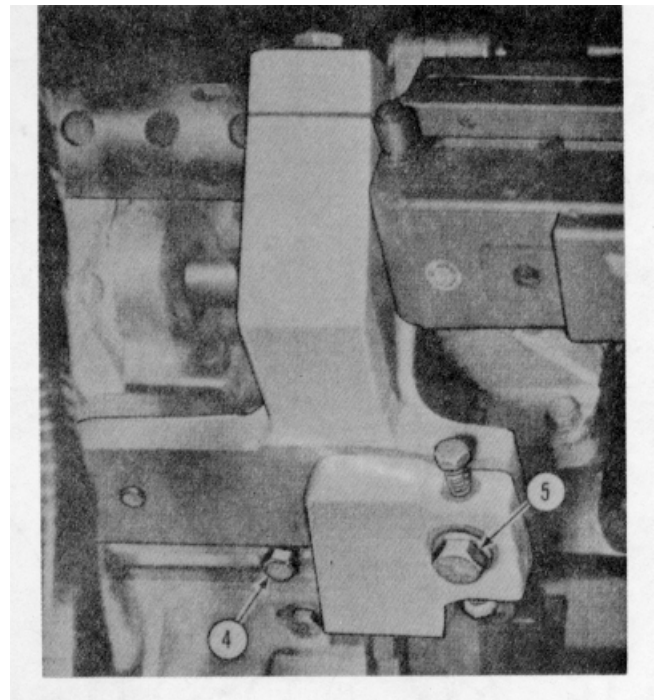
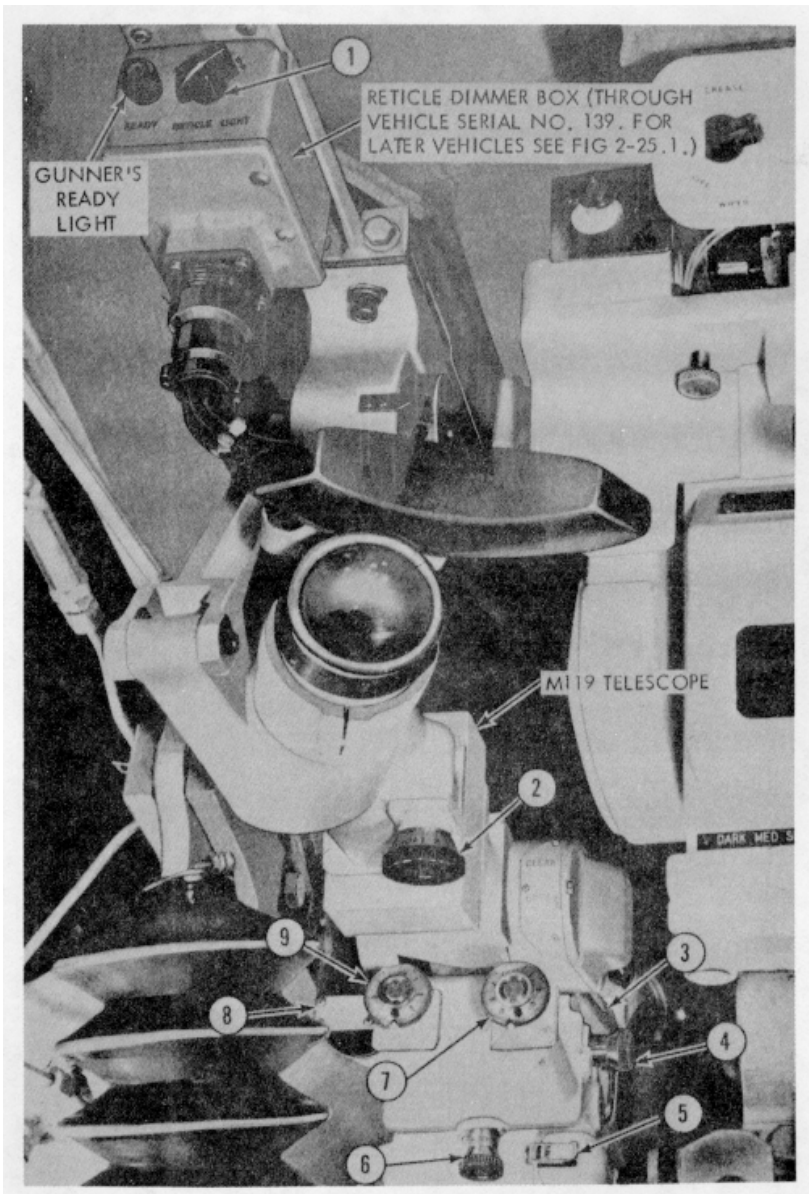
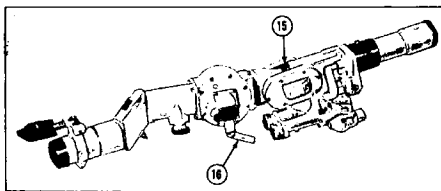

Figure 2-24. Aligning 7.62 mm machine gun



M119 TELESCOPE AND RETICLE DIMMER BOX

M119 TELESCOPE AND RETICLE DIMMER BOX



M127 TELESCOPE

M127 TELESCOPE

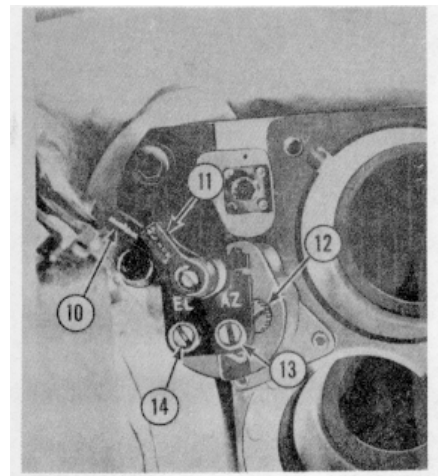

M149 MOUNT (TELESCOPE REMOVED FOR CLARITY)

1. RETICLE LIGHT RHEOSTAT KNOB
2. DIOPTRER KNOB (FOCUS ADJUSTMENT)
3. FILTER LEVER (CLEAR, NEUTRAL, DENSE)
4. AZIMUTH KNOB (MISSILE RETICLE)
5. CONVENTIONAL AMMUNITION RETICLE LAMP COVER LATCH
6. ELEVATION KNOB (MISSILE RETICLE)
7. AZIMUTH KNOB (CONVENTIONAL RETICLE)
8. MISSILE RETICLE LAMP HOUSING
9. ELEVATION KNOB (CONVENTIONAL RETICLE)
10. ERROR LEVER
11. ALIGN LEVER
12. CHECKSIGHT LAMP
13. AZ SCREW
14. EL SCREW
15. PARALLAX ADJUSTMENT (M119 OR M127)
16. MAGNIFICATION POWER LEVER (M127 ONLY)

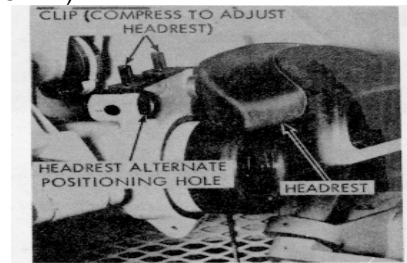

M119 OR M127 TELESCOPE HEADREST

WE 66592 U

Figure 2-25. Gunner's M119 or M127 telescope controls  
2-41

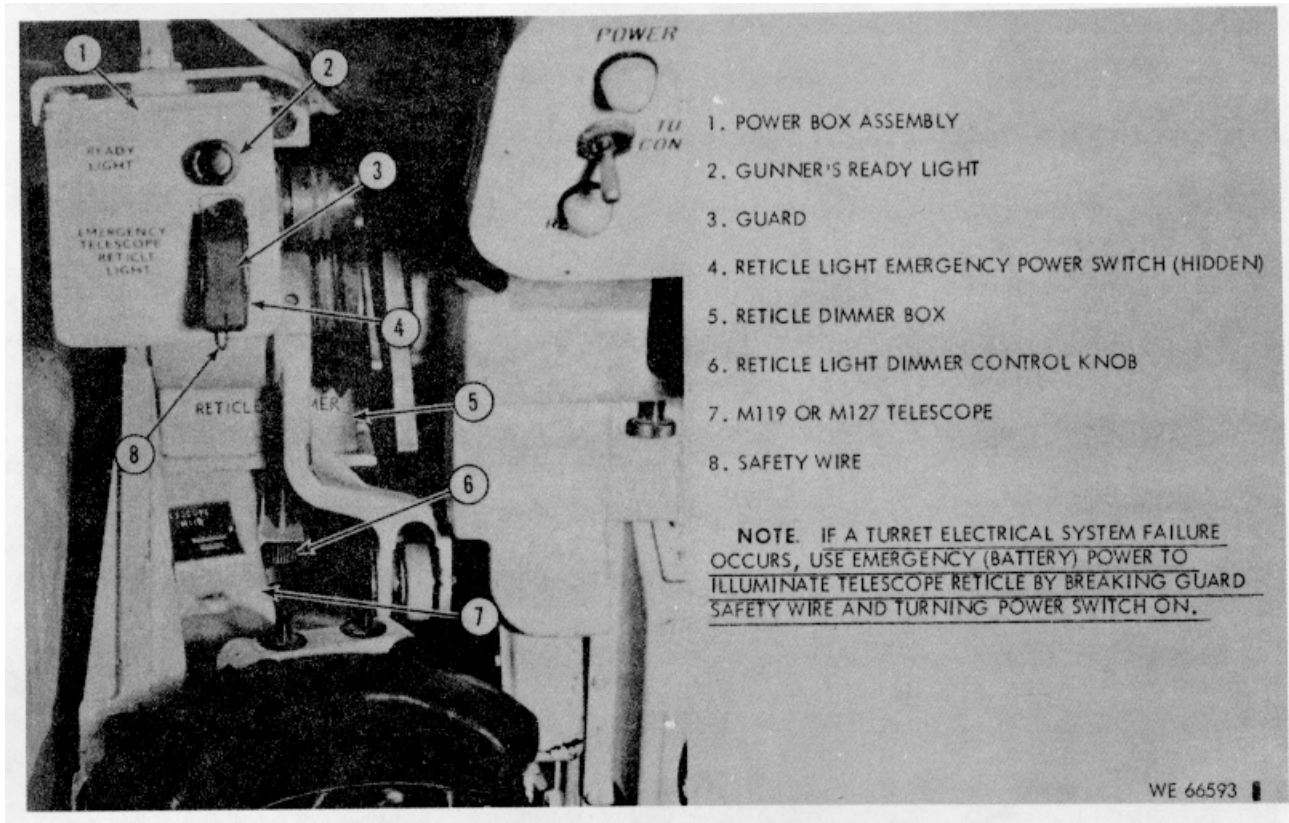

Figure 2-25.1. M119 or M127 telescope emergency reticle light power box assembly and reticle dimmer box (effective vehicle SN 140)

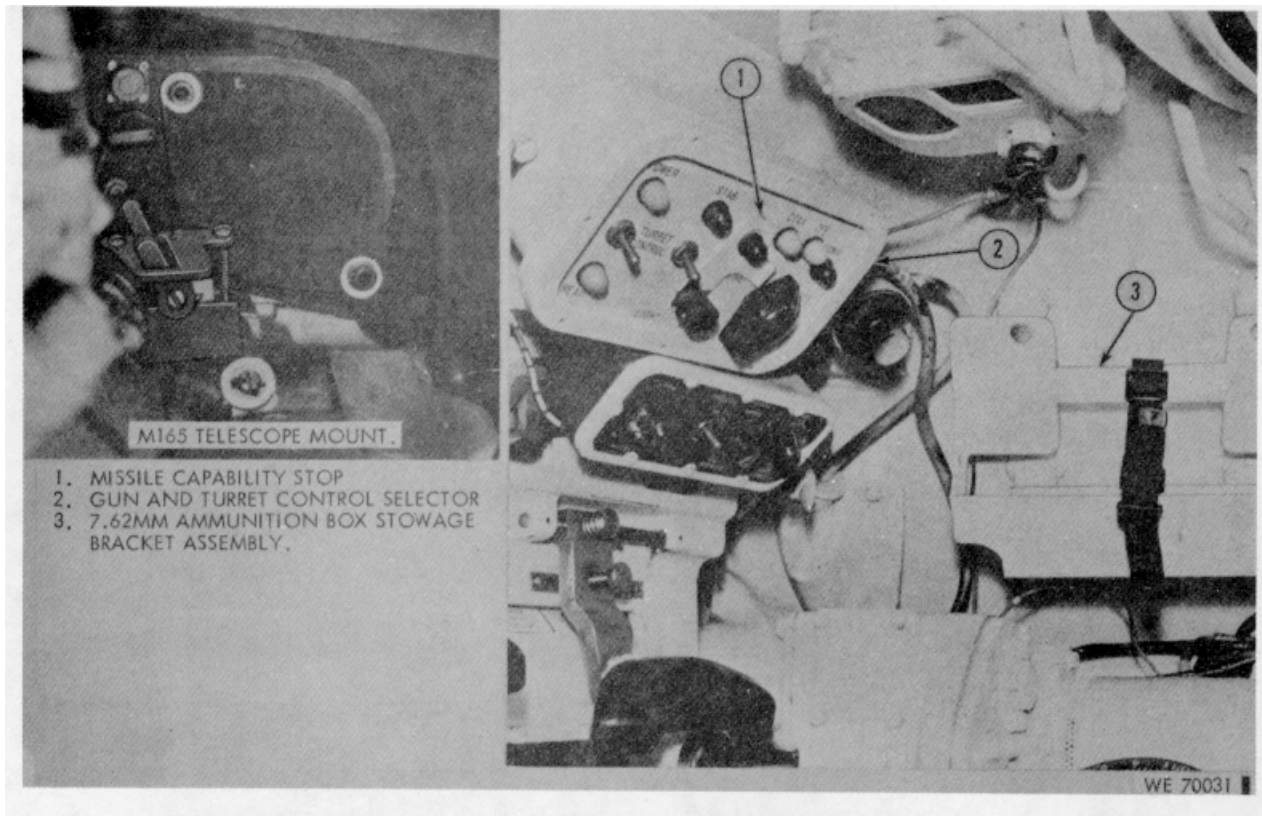
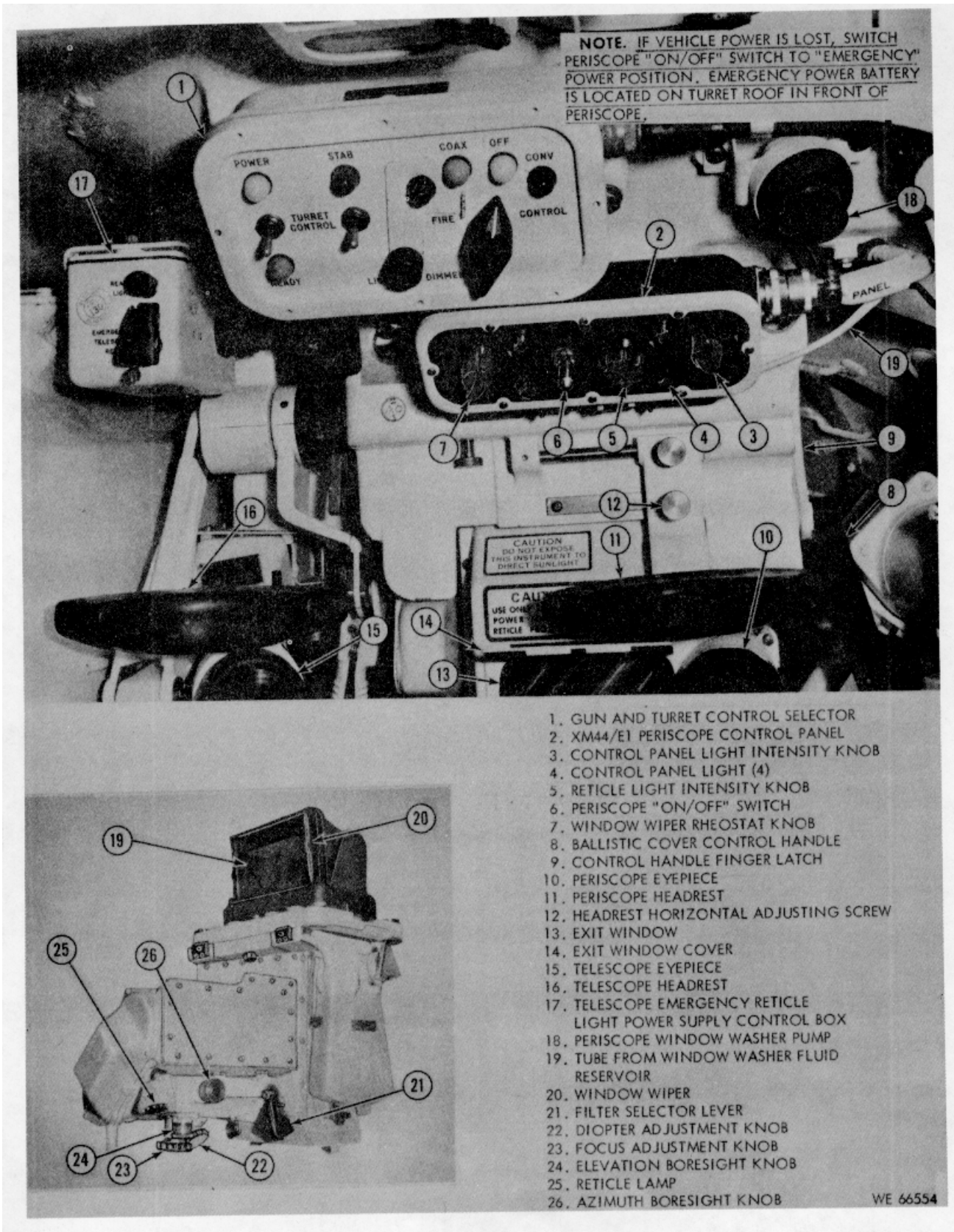

Figure 2-25. 2. Telescope mount M165 and gun and turret control selector on vehicles without missile capability.





1. GUN AND TURRET CONTROL SELECTOR
2. XM44/E1 PERISCOPE CONTROL PANEL
3. CONTROL PANEL LIGHT INTENSITY KNOB
4. CONTROL PANEL LIGHT (4)
5. RETICLE LIGHT INTENSITY KNOB
6. PERISCOPE "ON/OFF" SWITCH
7. WINDOW WIPER RHEOSTAT KNOB
8. BALLISTIC COVER CONTROL HANDLE
9. CONTROL HANDLE FINGER LATCH
10. PERISCOPE EYEPIECE
11. PERISCOPE HEADREST
12. HEADREST HORIZONTAL ADJUSTING SCREW
13. EXIT WINDOW
14. EXIT WINDOW COVER
15. TELESCOPE EYEPIECE
16. TELESCOPE HEADREST
17. TELESCOPE EMERGENCY RETICLE LIGHT POWER SUPPLY CONTROL BOX
18. PERISCOPE WINDOW WASHER PUMP
19. TUBE FROM WINDOW WASHER FLUID RESERVOIR
20. WINDOW WIPER
21. FILTER SELECTOR LEVER
22. DIOPTRER ADJUSTMENT KNOB
23. FOCUS ADJUSTMENT KNOB
24. ELEVATION BORESIGHT KNOB
25. RETICLE LAMP
26. AZIMUTH BORESIGHT KNOB

Figure 2-26. XM44 series periscope controls and instruments.



TABLE 2-10. OPERATION OF INDIRECT FIRE CONTROL INSTRUMENTS

STEP	PROCEDURE	FIG/ITEM
1	Traverse turret and elevate or depress 152MM gun-launcher until gunner's periscope (XM44 Series) or telescope (M1i9 or M127) conventional reticle is exactly on reference point.	2-23/E, F
2	Depress slightly and rotate resetter knob of azimuth indicator until micrometer pointer coincides with azimuth pointer. Depress resetter knob further and rotate both pointers to zero.	2-27
3	To determine the deflection to a given target, traverse the turret until the aiming cross of the gunner's periscope reticle is properly aligned on the target. Read directly from the azimuth indicator the sum of the micrometer and azimuth pointers.	2-27
4	To make small deflection corrections, rotate gunner's aid dial until zero graduation is opposite micrometer pointer. Use the micrometer pointer in conjunction with the gunner's aid (dial) to make a right or left shift of 50 mils or less in deflection.	2-27
5	Rotate micrometer elevation knob of M13A1C elevation quadrant until sum of elevation scale and micrometer scale readings equal required elevation angle. Elevate or depress gun-launcher until bubble in level vial is centered. Gun is now layed in elevation.	2-28/B
	<p><b>NOTE.</b> 1. <u>If possible, the vehicle should be positioned on level ground.</u></p> <p>2. <u>Either M1SAIC elevation quadrant or M1A1 gunner's quadrant may be used to lay gun in elevation. If M1A1 quadrant is used, note any deviation between centerline of weapon and quadrant seat (stamped above quadrant seat, fig. 2-28). If deviation exists, compensate by presetting quadrant.</u></p>	2-28
6	<p>Disengage index plunger from notches in frame of M1A1 gunner's quadrant by pressing plunger into index arm. Raise index arm and set index plate to nearest graduation on elevation scale below required elevation angle. Rotate micrometer knob to fine reading.</p> <p><b>NOTE.</b> <u>If required elevation angle is 327 mils, set index plate at 32C mils, and turn micrometer knob until scale indicates 7 mils: quadrant is now set at 327 mils.</u></p>	2-28/A
7	<p>Place shoes of M1A1 quadrant on quadrant seat of 152MM gun-launcher mount with inscribed arrow on quadrant pointing toward muzzle end of gun-launcher. Elevate or depress gun-launcher until bubble in level vial is centered. Gun-launcher is now layed in elevation.</p> <p><b>NOTE.</b> <u>Before using, wipe shoes of gunner's M1A1 quadrant and quadrant seat to insure accuracy.</u></p>	2-28/A

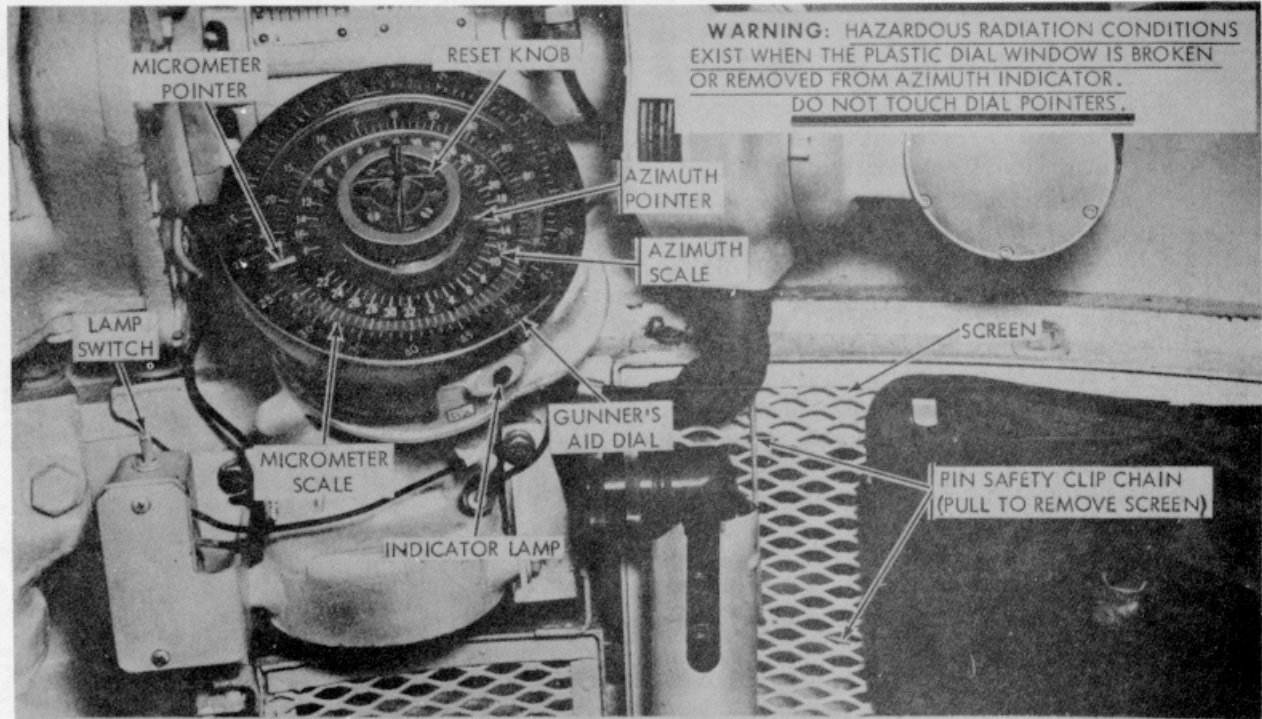

#### AZIMUTH INDICATOR ACCURACY TEST

1. LOOK THROUGH EYEPIECE OF GUNNER'S M119 OR M127 TELESCOPE AND LAY THE RETICLE AIMING CROSS ON A DEFINITE AIMING POINT (INTERSECTION OF HORIZONTAL AND VERTICAL LINES) BY OPERATING THE MANUAL ELEVATING AND TRAVERSING HANDLES.
2. DEPRESS RESET KNOB OF AZIMUTH INDICATOR AND ROTATE KNOB UNTIL MICROMETER AND AZIMUTH POINTERS ARE AT ZERO.
3. TRAVERSE THE TURRET MANUALLY THROUGH A COMPLETE CIRCLE UNTIL TELESCOPE RETICLE AIMING CROSS IS LAID ON THE ORIGINAL AIMING POINT. DO NOT OVER-TRAVEL ORIGINAL AIMING POINT.
4. ASSURE AZIMUTH INDICATOR MICROMETER AND AZIMUTH POINTERS ARE AT ZERO. IF BOTH POINTERS ARE NOT AT ZERO, NOTIFY ORGANIZATIONAL MAINTENANCE PERSONNEL.

#### AZIMUTH INDICATOR SLIPPAGE TEST

5. PERFORM STEPS 1 AND 2 ABOVE.
6. TRAVERSE THE TURRET RAPIDLY IN POWER AND STOP SUDDENLY. REPEAT TWO OR MORE TIMES IN THE SAME DIRECTION, THEN TURN OFF TURRET POWER.
7. MANUALLY TRAVERSE THE TURRET IN THE OPPOSITE DIRECTION UNTIL THE TELESCOPE RETICLE AIMING CROSS IS LAID ON THE ORIGINAL AIMING POINT.
8. ASSURE AZIMUTH INDICATOR MICROMETER AND AZIMUTH POINTERS ARE AT ZERO. IF BOTH POINTERS ARE NOT AT ZERO, NOTIFY ORGANIZATIONAL MAINTENANCE PERSONNEL.
9. IF BOTH POINTERS INDICATE ZERO, REPEAT STEPS 6 THROUGH 8 IN OPPOSITE DIRECTION.

WE 66695

Figure 2-27. Checking and adjusting azimuth indicator for accuracy and slippage

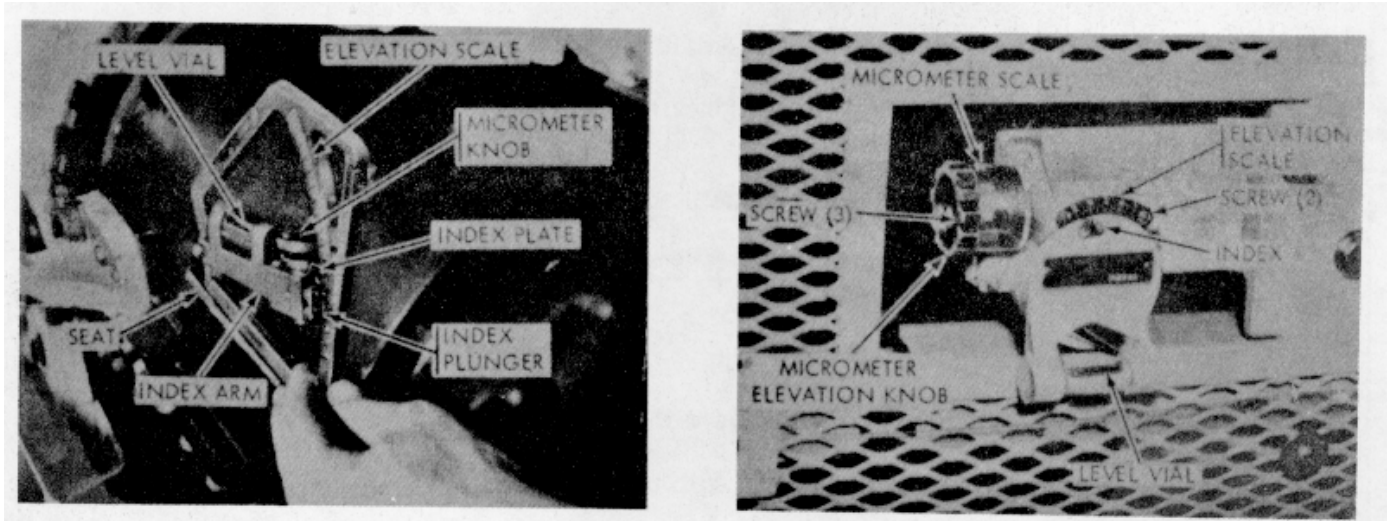

#### A. GUNNER'S M1A1 QUADRANT

##### DETERMINING M1A1 QUADRANT CORRECTION

1. MOVE VEHICLE TO APPROXIMATELY LEVEL GROUND.
2. SET M1A1 QUADRANT TO ZERO ELEVATION.
3. PLACE M1A1 QUADRANT ON QUADRANT SEAT AND ELEVATE OR DEPRESS GUN LAUNCHER TO CENTER BUBBLE IN QUADRANT LEVEL VIAL.
4. TURN QUADRANT END FOR END, AND CHECK TO SEE IF BUBBLE IS CENTERED.
  - A. IF BUBBLE IS CENTERED, QUADRANT CORRECTION IS ZERO.
  - B. IF BUBBLE CAN BE CENTERED WITH MICROMETER KNOB, DIVIDE MICROMETER READING BY 2. THIS IS A PLUS CORRECTION.
  - C. IF BUBBLE CANNOT BE CENTERED WITH MICROMETER KNOB, DROP INDEX PLUNGER 1 CLICK (10 MILS), THEN CENTER BUBBLE WITH MICROMETER KNOB. SUBTRACT MICROMETER READING FROM 10 AND DIVIDE BY 2. THIS IS A MINUS CORRECTION.
5. SET CORRECTION IN QUADRANT, DEPRESS OR ELEVATE GUN LAUNCHER TO CENTER BUBBLE, AND AGAIN TURN QUADRANT END FOR END. BUBBLE WILL BE CENTERED IF CORRECTION HAS BEEN ACCURATELY DETERMINED. IF NOT, REPEAT STEPS 2 THROUGH 5.

#### B. M13A1C ELEVATION QUADRANT.

##### ZEROING M13A1C QUADRANT

6. COMBINE M1A1 CORRECTION WITH QUADRANT SEAT CORRECTION (STAMPED ON QUADRANT SEAT). SET TOTAL CORRECTION ON M1A1 QUADRANT AND ELEVATE OR DEPRESS GUN LAUNCHER TO CENTER BUBBLE. GUN LAUNCHER IS NOW LEVEL.
7. ADJUST M13A1C QUADRANT WITH MICROMETER KNOB UNTIL BUBBLE IS CENTERED IN LEVEL VIAL.
8. IF MICROMETER SCALE DOES NOT READ ZERO, LOOSEN 3 SCREWS, PULL OUT ON KNOB AND ROTATE UNTIL ZERO READING IS OBTAINED. TIGHTEN SCREWS.
9. IF ELEVATION SCALE DOES NOT READ ZERO LOOSEN TWO SCREWS SECURING SCALE TO HOUSING AND ALIGN ZERO ON SCALE WITH INDEX. TIGHTEN SCREWS.

WE 12066

Figure 2-28. Adjusting M13A1C elevation quadrant

TABLE 2-11. INSTALLATION, OPERATION, AND BORESIGHT PROCEDURE FOR CAL .50  
MACHINE GUN NIGHT VISION SIGHT (FIG. 2-29)

STEP	PROCEDURE	FIG/ITEM
<b>INSTALLATION</b>		
1	Perform before operation preventive-maintenance checks and services (table 4-1, step 60).	
2	Unzip stowage bag and remove the night vision sight from retaining straps	13
3	Loosen four wing nuts, thumbscrews, and slide adapter bracket from stowage bracket.	11,12, 14
4	Slide adapter bracket into sight bracket and tighten lock levers	10,16
	<b>CAUTION:</b> <u>Never point the objective lens at the sun or other light source of comparable brightness.</u>	
5	Open machine gun cover and slide sight w/adapter bracket onto receiver. Close cover.	15,16
6	Tighten four thumb screws and secure with wing nuts.	11 and 12
7	Remove lens cap.	1
8	Remove battery cap. Install battery with positive end forward	7
<b>OPERATION</b>		
	<b>WARNING:</b> <u>Keep eyeshield in contact with face to prevent emission of visible glow from eyepiece.</u>	
9	Turn reticle lamp illumination switch on	6
10	Focus eyepiece by rotating focus ring until reticle pattern appears sharp	8
	<b>NOTE.</b> <u>Remember diopter scale setting for future quick focusing.</u>	
11	Unlock objective lens focus knob locking device	17
12	Focus objective lens with focus knob	2
13	Lock objective lens focus knob locking device, taking care not to disturb focus knob setting.	17
14	Rotate azimuth and elevation knobs to adjust position of reticle pattern	3 and 4
	<b>NOTE.</b> <u>Each click of azimuth and elevation adjustment knobs represents a 1/2 mil movement of the reticle. Total movement of either knob is plus or minus 26 mils.</u>	
<b>BORESIGHTING</b>		
15	Align cal..50 machine gun sights on a target at a distance of 150 meters.	
16	Align reticle aiming reference dot on same target	18
<b>AFTER OPERATION</b>		
17	Turn reticle lamp illumination switch off	6
18	Remove battery and install lens and battery caps	1,7
19	Remove sight and adapter bracket from gun and stow	13 and 14

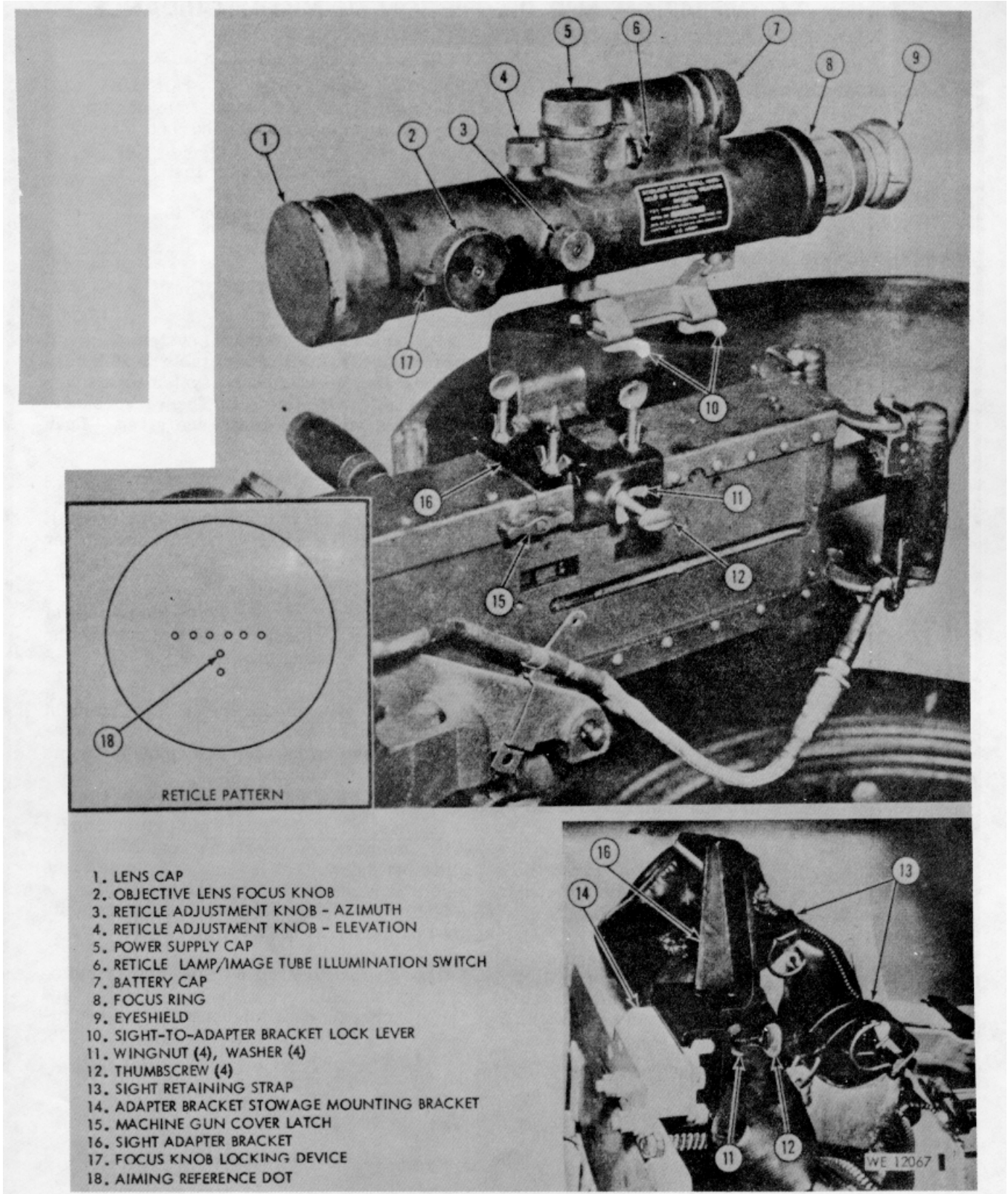

- 1. LENS CAP
- 2. OBJECTIVE LENS FOCUS KNOB
- 3. RETICLE ADJUSTMENT KNOB - AZIMUTH
- 4. RETICLE ADJUSTMENT KNOB - ELEVATION
- 5. POWER SUPPLY CAP
- 6. RETICLE LAMP/IMAGE TUBE ILLUMINATION SWITCH
- 7. BATTERY CAP
- 8. FOCUS RING
- 9. EYESHIELD
- 10. SIGHT-TO-ADAPTER BRACKET LOCK LEVER
- 11. WINGNUT (4), WASHER (4)
- 12. THUMBSCREW (4)
- 13. SIGHT RETAINING STRAP
- 14. ADAPTER BRACKET STOWAGE MOUNTING BRACKET
- 15. MACHINE GUN COVER LATCH
- 16. SIGHT ADAPTER BRACKET
- 17. FOCUS KNOB LOCKING DEVICE
- 18. AIMING REFERENCE DOT

Figure 2-29. Night vision sight for cal. .50 machine gun

## Section 2-6. OPERATION AND DESCRIPTION OF MISSILE GUIDANCE AND CONTROL SYSTEM

### 2-7. GUIDANCE AND CONTROL SYSTEM DESCRIPTION

The guidance and control system for the missile consists of the following components: tracker, rate sensor, signal data converter, modulator, power supply, test checkout panel, and the transmitter. These components control the missile during its flight from the gun-launcher to the target (see fig. 2-30).

a. Optical Tracker. This unit is the "eye" of the system and is mounted just above, and aligned with, the gunner's telescope. During a missile firing, it tracks the in-flight missile, determines how far it has moved from the line of sight, then sends the information to the signal data converter (SDC).

b. Rate Sensor. The rate sensor produces signals corresponding to the rate of turret traverse, gun elevation or depression. These signals are sent to the signal data converter to assist in making it possible for the missile to follow a moving line of sight as the gunner is tracking a moving target.

c. Signal Data Converter. The SDC is the command center of the guidance and control system. The SDC combines signal output from the tracker with turret traverse and gunlauncher elevation rate information from the rate sensor to compute corrections necessary to keep the missile on the line of sight. The correction signals are then sent to the modulator as missile command signals.

d. Modulator. The modulator takes the signals from the signal data converter and converts them to high current output to operate the transmitter.

e. Optical Transmitter. The transmitter converts the high current electrical signals into infrared signals. A narrow infrared beam, containing guidance command signals is then sent to the missile.

f. Test Checkout Panel. This panel (fig. 2-31) is used to initiate the following operational tests of the guidance and control system:

- (1) Lamp and meter test
- (2) Transmitter test
- (3) Tracker alignment test
- (4) System self test

#### 2-7.1. OPERATING INSTRUCTIONS

The guidance and control system checkout procedures are outlined in table 2-12 below. A complete checkout of the system is accomplished in four basic tests. These tests should be performed in the sequence given. Each test is described below.

a. Lamp and Meter Test. This test checks that all lamps on the test checkout panel will light and that the test checkout panel null meter is operating properly.

b. Transmitter Test. This test checks that both transmitter lamps will light and that the transmitter is operating properly.

c. Tracker Alignment Test. This test aligns the missile reticle in the gunner's telescope so that the gunner is viewing the same line of sight as the tracker.

d. System Self Test. This test automatically analyzes the operating condition of the guidance and control system and displays the result as a red no/go lamp for the unit that is defective or as a green GO lamp if all units are functioning normally.

**NOTE.** Before operation, the crew should be familiarized with the location and operation of all controls and instruments (figs. 2-19, 2-23, 2-25, 2-26, 2-30 and 2-31).

TABLE 2-12. MISSILE GUIDANCE AND CONTROL SYSTEM CHECKOUT PROCEDURES

STEP	PROCEDURE	FIG/ITEM
<b>PRELIMINARY INSTRUCTIONS</b>		
<b>NOTE.</b> Steps 2, 3, 4 and 6 are performed only when a missile firing is to occur immediately after completion of check-out procedures.		
1	Perform before-operation preventive-maintenance checks and services (table 4-1, sequence no. 61 and 62).	
1A	Boresight conventional and missile reticle patterns (table 2-9).	
2	Turn and push control handle to open transmitter door. Turn handle clockwise to lock door open.	2-26/14
3	Turn TURRET CONTROL POWER switch off	2-19
4	Set SAFE/READY switch on loader's control box to SAFE position	3-1A
<b>ENERGIZING THE GUIDANCE AND CONTROL SYSTEM</b>		
5	Start vehicle engine and set- idle speed to at least 1750 rpm (table 2-3, steps 1 through 19).	2-9
6	Turn TURRET CONTROL POWER switch on if operating turret in power mode (table 2-7). Lamp above switch will glow.	
7	Turn FIRE CONTROL selector to MISSILE position. Lamp above switch will glow, POWER SUPPLY lamp on test checkout panel will blink during warm-up but will go out when system is warmed up, and missile reticle appears in telescope	2-31/5 2-23D
<b>LAMP AND METER TEST</b>		
8	Hold LAMP AND METER TEST switch on test checkout panel in the UP position. All the lamps on test checkout panel should glow and null meter needle should deflect to METER TEST band	2-31/12 2-31 2-31/1
9	Rotate DIMMER control on test checkout panel. Brightness of all lamps except the red lamps should vary.	2-31/10
10	Release LAMP AND METER TEST switch	2-31/12
<b>TRANSMITTER TEST</b>		
<b>WARNING:</b> <u>Do not look directly into transmitter regardless of distance. Transmitter emits invisible infrared rays which can cause serious eye damage.</u>		
<b>CAUTION:</b> <u>Do not leave XMTR TEST switch in up position for more than 1 minute.</u>		
11	Set XMTR TEST switch on test checkout panel to up position. XMTR TEST and XMTR lamps should glow. If transmitter is defective XMTR TEST switch will return to down position in approximately 10 seconds. If this occurs, notify organizational maintenance.	2-31/13
<b>2-48.1</b>		

TABLE 2-12. MISSILE GUIDANCE AND CONTROL SYSTEM CHECKOUT PROCEDURES—Continued

STEP	PROCEDURE	FIG/ITEM
<b>TRANSMITTER TEST - Continued</b>		
12	Hold RESET switch on test checkout panel up and then release XMTR TEST switch returns to down position	2-31/11 2-31/13
<b>TRACKER ALIGNMENT TEST</b>		
13	Move ALIGN lever on the telescope mount to the fully right position	2-25/11
13A	Check to insure that ERROR lever is in its extreme left position	2-25/10
13B	Check to insure telescope filter lever is in CLEAR position	2-25/3
14	Set TRACKER ALIGN switch on test checkout panel to up position TRACKER ALIGN lamp should glow, and a spot of light should appear in the telescope. If necessary, temporarily cover or shade the telescope opening outside the turret to make the spot of light more visible.	2-31/14
15	Set AZ/EL switch on test checkout panel to AZ (down) position. AZ lamp should glow and null meter needle should indicate in center of lower green band. If not, adjust AZ screw located beneath ALIGN lever on telescope mount to bring needle into center of lower green band.	2-31/16 2-15/13
16	Set AZ/EL switch to EL (up) position. EL lamp should glow, and null meter needle should indicate in center of lower green band. If not, adjust EL screw located beneath ALIGN lever on telescope mount to bring needle into center of lower green band.	2-31/16 2-25/14
17	Repeat steps 15 and 16 to insure there is no interaction of adjustments .	
18	Look into telescope and using missile azimuth and elevation knobs, center missile reticle circle over checksight spot of light.	2-54/4, 6
19	Hold RESET switch on test checkout panel up and then release TRACKER ALIGN switch returns to down position, and ALIGN lever moves to the left and the spot of light disappears	2-31/11 2-31/14 2-25/11
<p><b>NOTE.</b> <u>Whenever there is a rapid temperature change of 30°F or more, repeat tracker alignment test.</u></p>		
<b>SYSTEM SELF TEST</b>		
20	Move ALIGN and ERROR levers on the telescope mount to fully right position.	2-25/10, 11
<p><b>NOTE.</b> <u>If align lever resets left at any time during system self-test immediately reposition lever to extreme right and continue with self-test.</u></p>		
2-48.2		

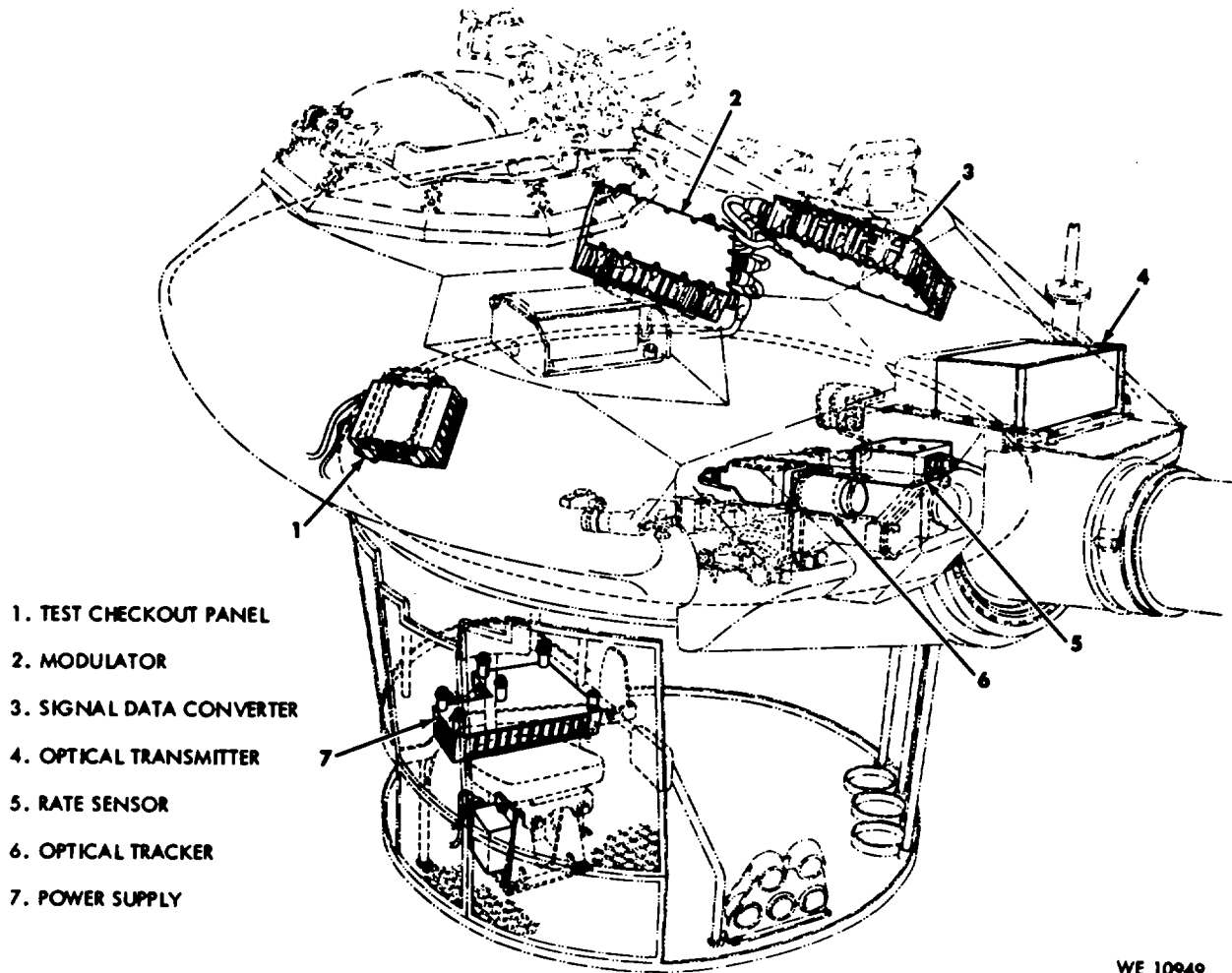

TABLE 2-12. MISSILE GUIDANCE AND CONTROL SYSTEM CHECKOUT PROCEDURES-Continued

STEP	PROCEDURE	FIG/ITEM
<b>SYSTEM SELF TEST - Continued</b>		
21	Set SYSTEM TEST switch on test checkout panel to up position. SYSTEM TEST and AZ or EL lamps should glow. The GO lamp should glow after 30 second delay. If a guidance and control unit malfunctions, its corresponding lamp will glow and the GO lamp will not glow. If a malfunction occurs hold the RESET switch up and then release. De-energize the system (steps 28 through 33) and notify organizational maintenance.	2-31/15  2-31/11
22	Set the AZ/EL switch to the AZ (down) position. AZ lamp should glow.	2-31/16
23	Traverse turret to left and right (table 2-7) Null meter needle moves in the same direction as turret. When movement ceases, needle returns to lower green null band. If not, notify organizational maintenance.	2-31/1
24	Set AZ/EL switch to the EL (up) position. The EL lamp glows.	2-31/16
25	Move gun-launcher up and down. Null meter needle moves to the right as gun-launcher is raised and to the left as gun-launcher is lowered. When movement ceases, needle returns to lower green null band. If not, notify organizational maintenance.	
26	Hold RESET up and then release. SYSTEM TEST switch returns to down position. ALIGN lever returns to the left.	2-31/11
27	Move ERROR lever on telescope mount to the left.	2-25/10
<b>SYSTEM SELF TEST VERIFICATION</b>		
27A	Move ALIGN and ERROR levers on telescope mount to fully left position.	2-25/10, 11
27B	Set the SYSTEM TEST switch on the test checkout panel to up position. TRACKER lamp should glow. If not, notify organizational maintenance.	2-31/16
27C	Hold RESET switch up and then release.	2-31/11
27D	Repeat step 27B with ALIGN lever positioned fully right and ERROR lever fully left. SIG DATA CONV lamp should glow. If not notify organizational maintenance.	
27E	Hold RESET switch up and then release.	
<b><u>WARNING: Before proceeding, insure that all weapons are cleared of live rounds.</u></b>		
27F	Set SAFE/READY switch on loader's control box to READY position. Move ALIGN lever fully right and ERROR lever fully left. Insure that gunner's READY lamp is glowing. Set the SYSTEM TEST switch to the up position then pull the fire trigger.	

## TALE 2-12. MISSILE GUIDANCE AND CONTROL SYSTEM CHECKOUT PROCEDURES-Continued

STEP	PROCEDURE	FIG/ITEM
	<p><b>SYSTEM SELF TEST VERIFICATION (Continued)</b></p> <p>Test checkout panel should reset; ALIGN lever should move fully left; and the tracker motor should run for approximately 3 seconds. If not, notify organizational maintenance.</p> <p><b>DE-ENERGIZING THE MISSILE SUBSYSTEM</b></p> <p><b>NOTE.</b> <u>Do not de-energize the subsystem if going directly into a firing mission.</u></p>	
28	Check to insure that SAFE/READY switch is in SAFE position	3-1/A
29	Turn FIRE CONTROL selector to OFF position. MISSILE lamp goes out.	2-19
30	Turn TURRET CONTROL POWER switch OFF. Lamp above switch goes out.	2-19
31	Stop vehicle engine (table 2-3).	
32	Close transmitter door, and turn handle clockwise to lock door closed.	2-26/14
33	Perform after-operation preventive-maintenance checks and services (table 4-1, steps 127 and 128).	



WE 10949

Figure 2-30. Missile subsystem units

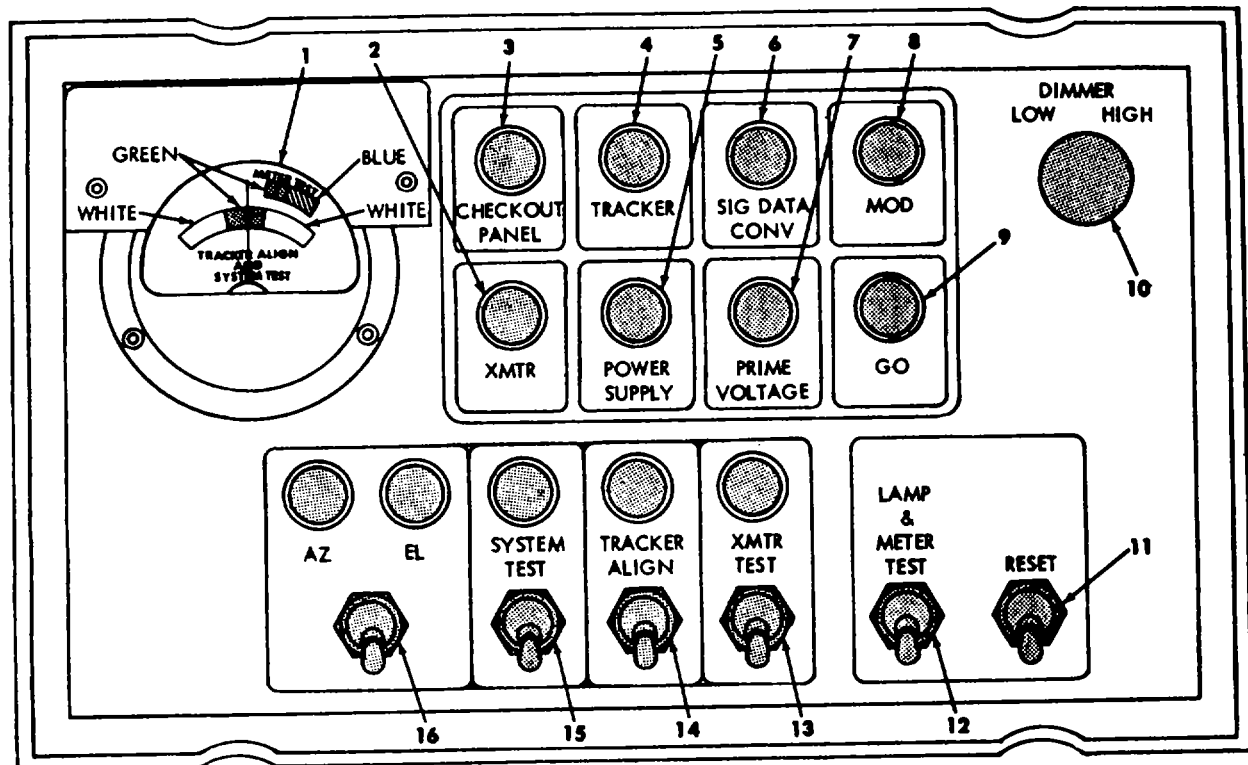

1. NULL METER. INDICATES ALIGNMENT OF TRACKER DURING TRACKER ALIGNMENT TEST AND OPERATIONAL CONDITION OF RATE SENSOR DURING SYSTEM SELF TEST
2. XMTR LAMP (RED). INDICATES OPERATIONAL CONDITION OF THE TRANSMITTER DURING SYSTEM SELF TEST.
3. CHECKOUT PANEL LAMP (RED). INDICATES OPERATIONAL CONDITION OF THE TEST CHECKOUT PANEL DURING SYSTEM SELF TEST.
4. TRACKER LAMP (RED). INDICATES OPERATIONAL CONDITION OF THE TRACKER DURING SYSTEM SELF TEST.
5. POWER SUPPLY LAMP (RED). INDICATES OPERATIONAL CONDITION OF THE POWER SUPPLY DURING SYSTEM OPERATION.
6. SIG DATA CONV LAMP (RED). INDICATES OPERATIONAL CONDITION OF THE SIGNAL DATA CONVERTER DURING SYSTEM SELF TEST.
7. PRIME VOLTAGE LAMP (AMBER). IF LAMP GLOWS AFTER SYSTEM WARM-UP THE VEHICLE POWER TO THE SYSTEM IS LOW.
8. MOD LAMP (RED). INDICATES OPERATIONAL CONDITION OF THE MODULATOR DURING SYSTEM SELF TEST.
9. GO LAMP (GREEN). INDICATES OPERATIONAL CONDITION OF GUIDANCE AND CONTROL SYSTEM DURING SELF TEST.
10. DIMMER CONTROL. ADJUSTS THE BRIGHTNESS OF ALL LAMPS EXCEPT THE RED NO/GO LAMPS.
11. RESET SWITCH. TURNS OFF ALL CONTROL SIGNALS. USED DURING TRACKER ALIGNMENT TEST, SYSTEM SELF TEST, AND TRANSMITTER TEST.
12. LAMP AND METER TEST SWITCH. INITIATES THE TEST OF ALL LAMPS AND THE NULL METER ON THE TEST CHECKOUT PANEL.
13. XMTR TEST SWITCH AND LAMP (WHITE). SWITCH TURNS ON BOTH TRANSMITTER LAMPS DURING TRANSMITTER TEST.
14. TRACKER ALIGN SWITCH AND LAMP (WHITE). INITIATES THE ALIGNMENT TEST OF THE TRACKER.
15. SYSTEM TEST SWITCH AND LAMP (WHITE). INITIATES THE SYSTEM SELF TEST.
16. AZ/EL SWITCH AND LAMPS (WHITE). SELECTS AZIMUTH AND ELEVATION SIGNALS FROM THE RATE SENSOR FOR TEST. IT IS ALSO USED DURING THE ALIGNMENT TEST OF THE TRACKER TO INDICATE AZIMUTH AND ELEVATION ALIGNMENT.

WE 10908B

Figure 2-31. (Superseded) Missile subsystem test checkout panel

**Section 2-7. OPERATION OF SPECIAL PURPOSE KITS**

**2-8. Operation Instructions**

The following tables and illustrations provide special purpose kits operating instructions.

**2-9. Operation of Winterization Kit Coolant Heater (table 2-13)**

The winterization kit coolant heater is to be used when engine is shutdown in ambient temperatures at -250F. to -650F., to raise engine oil, engine coolant and battery electrolyte temperatures.

**2-10.** -Deleted.

**2-11. Searchlight Kit (tables 2-14.15.16)**

**TABLE 2-13. OPERATION OF ENGINE COOLANT HEATER (-250F. TO -650F.)**

STEP	PROCEDURE	FIG/ITEM
<b>BEFORE OPERATION</b>		
1	Fold back and secure flap on forward left corner of grille cover to uncover heater exhaust pipe.	2-32
<p><b>WARNING:</b> <u>When operating winterization kit coolant heater, turret must be positioned so that neither grenade projector is over the heater exhaust outlet.</u></p>		
<b>STARTING AND OPERATING HEATER</b>		
<p><b>NOTE.</b> <u>The duration of time that the winterization kit can be operated is dependent upon the amount of battery capacity available. Care should be taken not to operate other vehicle electrical equipment while the kit is in operation. Three to 5 hours of kit operation is required prior to attempting an engine start on a cold soaked vehicle.</u></p>		
2	Vehicle master switch should be in the "OFF" position	2-10
<p><b>NOTE.</b> <u>Heater may be operated with vehicle master switch in "ON" or "OFF" position. It is recommended that the "OFF" position be used to minimize battery drain.</u></p>		
3	Be sure fuel supply valve on center fuel tank is open.	
4	Depress coolant heater control box indicator light to test. Indicator light will illuminate.	2-32/2
<p><b>NOTE.</b> <u>If indicator light does not illuminate, replace lamp and/or determine cause for lack of electrical continuity.</u></p>		
5	Place heat selector switch in "LO" position	2-32/1
6	Hold heat control switch in "START" position until indicator light illuminates (1 to 3 minutes).	
<p><b>CAUTION:</b> <u>If indicator light does not illuminate within 3 minutes, turn heat control switch to "OFF" position and wait 5 minutes. Repeat step 5 to make a second attempt to start heater. If the light does not illuminate after a third attempt, turn heat control switch to "OFF" position and refer to Organizational Maintenance Personnel.</u></p>		
7	Snap heat control switch to "RUN" position	2-32/1
8	Place heat selector switch in "HI" position 10 minutes after the indicator light on the control box has illuminated.	2-32/1, 2

TABLE 2-13. OPERATION OF COOLANT HEATER (-25°F. TO -650F.) - CONTINUED

STEP	PROCEDURE	FIG/ITEM
<b>STARTING AND OPERATING HEATER - CONTINUED</b>		
<p><b>NOTE:</b> <u>The heat selector switch should remain in the "HI" heat position during prolonged use of the winterization kit. The coolant thermostat will automatically switch the heater from high to low heat thereby maintaining proper system temperatures.</u></p>		
<b>BEFORE STARTING ENGINE</b>		
9	Unfasten 2 or 4 straps on engine intake grille cover and roll cover into smallest possible tube form and secure straps onto unused spacers at forward end of exhaust grille.	2-32/5, 7
10	Unfasten 3 or 5 straps on exhaust grilles cover and roll cover into smallest possible tube form, securing straps onto spacers at rearward end of intake grille.	2-32/6, 8
11	During prolonged engine operation or during main weapon firing, remove grille cover.	2-32/4
12	Place heat control switch to center "OFF" position. Indicator light will remain illuminated and blower will continue to run for 2 or 3 minutes until the combustion chamber has been purged.	2-32/2, 3
13	Start vehicle engine.	
<p><b>NOTE.</b> <u>Do not operate winterization heater when engine is running.</u></p>		
<b>AFTER OPERATION</b>		
14	Shut-down vehicle engine.	
15	Secure grille cover in the closed position	2-32/4

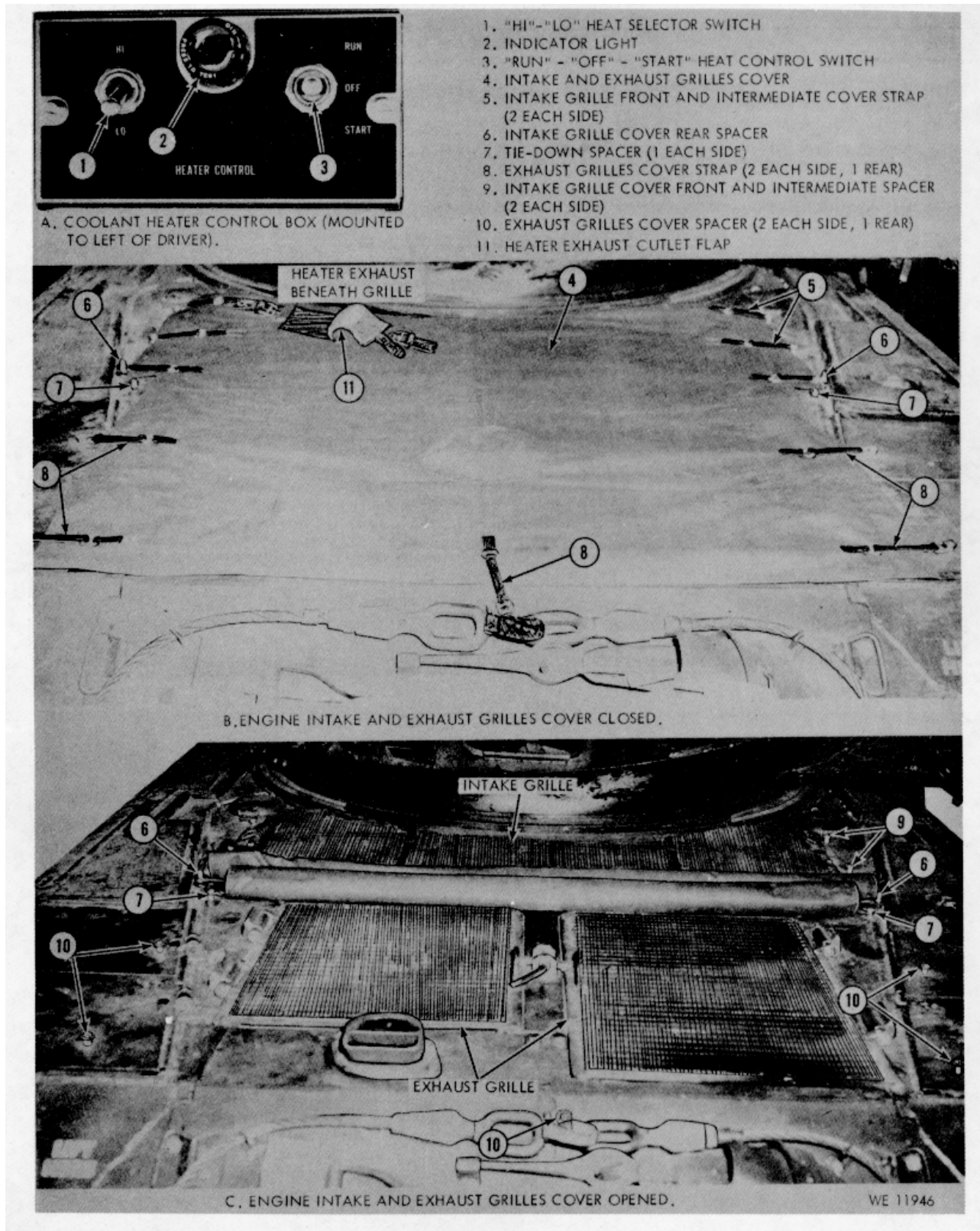
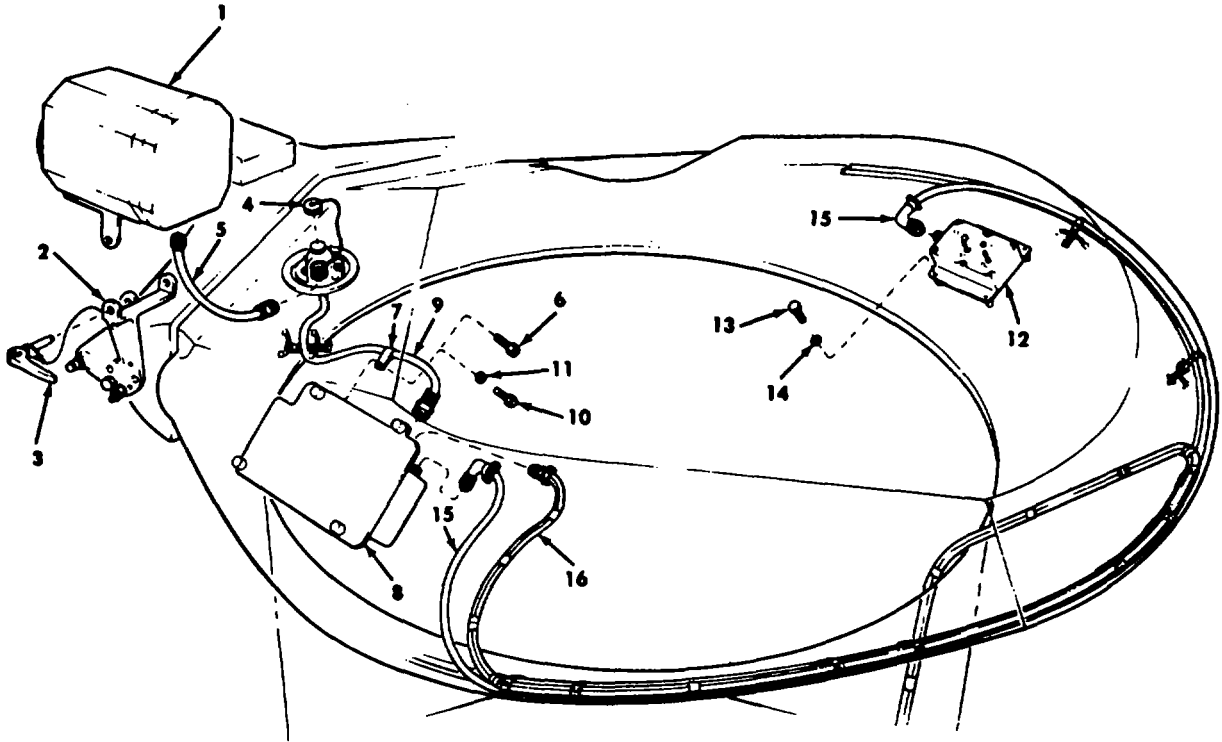

Figure 2-32. Winterization kit

Figure 2-33. Deleted

(2-56 Blank) 2-55

**LEGEND**

1. SEARCHLIGHT W/SUPPORT
2. MOUNTING BRACKET
3. LOCKING PIN (3)
4. HOUSING CAP
5. SEARCHLIGHT-TO-ROOF WIRING HARNESS
6. SCREW
7. CLAMP
8. MAIN CONTROL BOX
9. ROOF-TO-MAIN CONTROL BOX WIRING HARNESS
10. SCREW (4)
11. WASHER (4)
12. REMOTE CONTROL BOX
13. SCREW (4)
14. WASHER (4)
15. MAIN CONTROL BOX-TO-REMOTE CONTROL BOX WIRING HARNESS
16. MAIN CONTROL BOX-TO-ELECTRICAL CONTACT RING WIRING HARNESS

REFER TO TABLE 2-14 FOR STEP BY STEP INSTALLATION PROCEDURE.

WE 11963

Figure 2-34. (Superseded) Infrared searchlight kit installation.



TABLE 2-14. INFRARED SEARCHLIGHT KIT INSTALLATION (FIG. 2-34)

	F. S. N	Mfr 's Part No	Item
Infrared Searchlight Kit	5855-058-1293	AN/VSS-3	
Consisting of:			
1 - Main Control Box w/attaching Hardware .....	5855-135-0155	C-7905/VSS-3	8, 10, 11
1 - Remote Control Box w/attaching Hardware ....	5855-135-0154	C-7906/VSS-3	12, 13,14
1 - Searchlight w/support.....	5855-135-0156	MX8272/VSS-3	1
1 - Cable Assembly (Searchlight-to-Roof).....	Not Available	CX-11893/VSS-3	5

## STEP INSTALLATION PROCEDURE

**WARNING:** Make certain that VEHICLE MASTER switch is turned to the OFF position.

- 1 Position searchlight with support (1) onto mounting bracket (2) and secure with 3 cam operated locking pins (3) (See note, figure 2-35).
- 2 Remove housing cap (4) and connect searchlight-to-roof harness at each end (5). Stow cap on threads provided on top of housing.
- 3 Remove and discard existing screw (6) securing clamp and roof-to-main control box wiring harness (7).
- 4 Install main control box (8), clamp (7), and roof-to-main control box wiring harness (9) and secure with 4 screws and washers (10 and 11). Connect wiring harness at main control box.
- 5 Position remote control box (12) and secure with 4 screws and washers.
- 6 Connect main control box-to-remote control box wiring harness (15) at each end.
- 7 Connect main control box-to-electrical contact ring wiring harness (16) at control box.

## SEARCHLIGHT LAMP REPLACEMENT

- 1 Remove searchlight front cover and remove spare lamp from container.
- 2 Place container over burned out lamp, engaging container ferrule with base of lamp. Unscrew lamp counterclockwise and remove.
- 3 Place container over replacement lamp and install lamp in searchlight.
- 4 Remove container and install searchlight front cover.

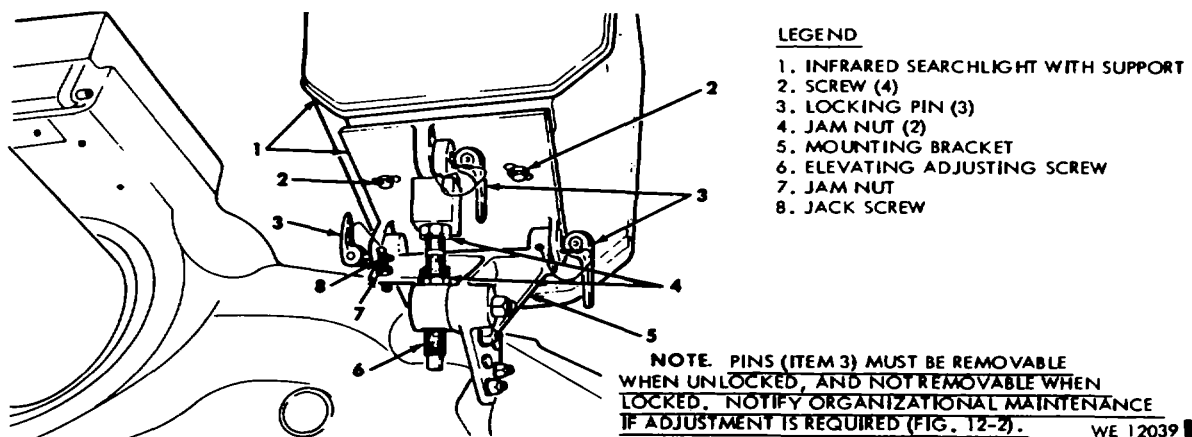

Figure 2-35. Searchlight with support and mounting bracket.

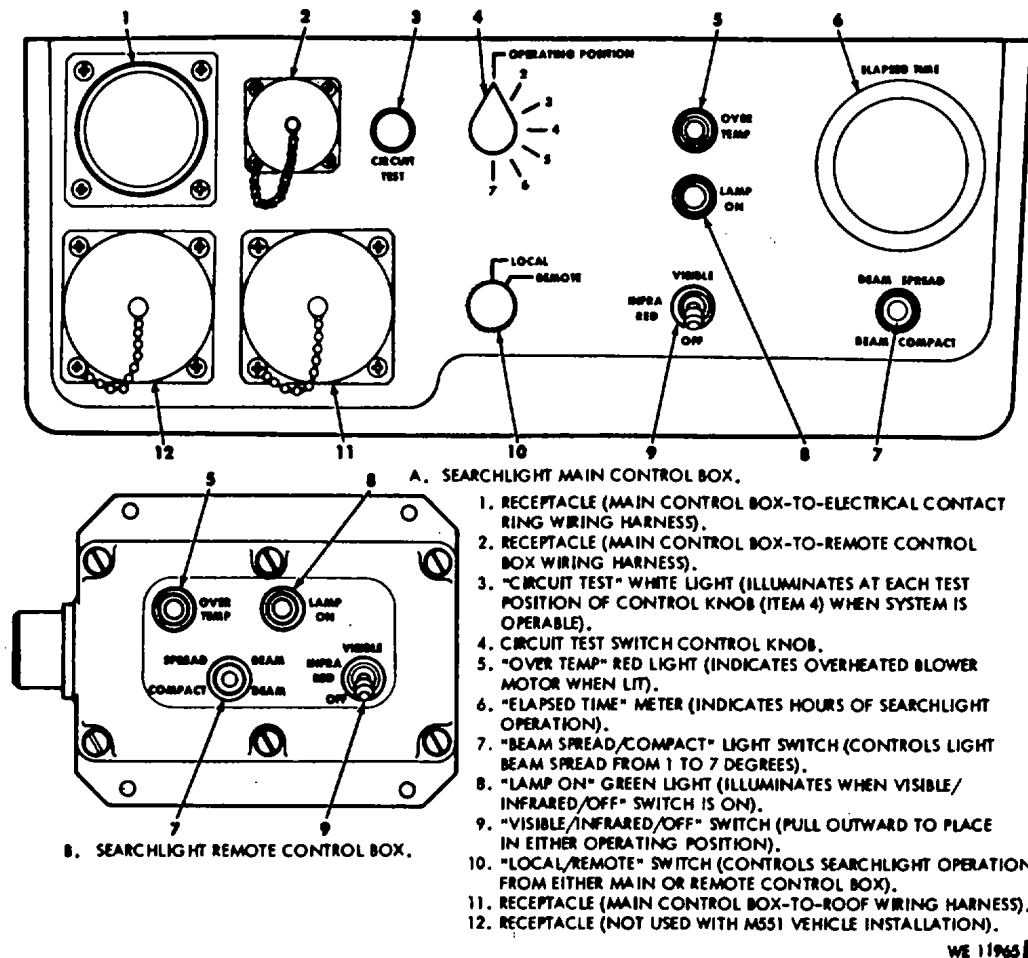

Figure 2-36. (Added' Main and remote searchlight control boxes.

TABLE 2-15. INFRARED SEARCHLIGHT OPERATION

STEP	PROCEDURE
	<b>WARNING:</b> <u>DO NOT</u> look into searchlight beams. Serious eye damage can result.
<b>BEFORE OPERATION</b>	
1	Clean searchlight exterior and make certain all connections are securely tightened.
2	Bracket jack screw and jam nut (7, 8, fig. 2-35) must be in firm contact with gun shield.
3	Make certain the VISIBLE/INFRARED/OFF switch (9, fig. 2-36) is in OFF position.
4	Remove searchlight front canvas cover and stow.
<b>NOTE.</b>	<u>If window is dirty, clean with a dry or water dampened cloth.</u>
<b>WARNING:</b>	<u>DO NOT</u> clean when light is in operation.

TABLE 2-15. INFRARED SEARCHLIGHT OPERATION - CONTINUED

STEP	PROCEDURE
	<b>OPERATION</b>
5	Start vehicle engine and run at fast idle (table 2-3 or 2-4. 1).
	<b>CAUTION:</b> <u>DO NOT operate searchlight without engine running.</u>
6	Position LOCAL/REMOTE switch (10, fig. 2-36) on main control box as desired.
	<b>NOTE.</b> <u>The LOCAL/REMOTE switch on the main control box controls searchlight useage and is operated at the main control box when in LOCAL position and at the remote control box when in REMOTE position.</u>
7	Pull outward on VISIBLE/INFRARED/OFF 3 position toggle switch (9, fig. 2-36) and place in desired position. Green LAMP ON light (8, fig. 2-36) will illuminate and searchlight lamp will ignite.
	<b>NOTE. 1.</b> <u>If the first ignition attempt does not illuminate the lamp, the ignition process is automatically repeated.</u>
	<b>NOTE. 2.</b> <u>If searchlight does not ignite after 15 to 20 seconds perform searchlight system self test with circuit test switch knob (4, fig. 2-36) on main control box. If system is found operable, lamp (300 hours minimum operation) may be defective. Refer to table 2-14 for lamp replacement.</u>
8	Place BEAM switch (7, fig. 2-36) in SPREAD light or COMPACT light position.
	<b>NOTE.</b> <u>The operator can control the SPREAD light beam by very quickly pressing switch on and off and obtain a light spread from 1 to 7 degrees,</u>
	<b>CAUTION:</b> <u>If during operation, the OVER TEMP red light (5, fig. 4) comes on, due to blower motor failure, turn searchlight off and notify Organizational Maintenance Personnel.</u>
	<b>AFTER OPERATION</b>
9	Turn VISIBLE/INFRARED/OFF switch (9, fig. 2-36) to OFF position. Green LAMP ON light (8, fig. 2-36) and searchlight go out.
	<b>WARNING:</b> <u>DO NOT disconnect electrical harness or open equipment for any reason until after system has been shut down, and blower motor in searchlight has stopped.</u>
	<b>CAUTION:</b> <u>DO NOT turn VEHICLE MASTER switch off until the searchlight blower motor shuts off. The blower motor is automatically controlled by a temperature sensing switch in the searchlight.</u>
10	Install searchlight canvas front cover.
11	If searchlight and support are removed, stow elevation adjustment screw in clip.
	<b>2-60</b>

TABLE 2-16. BORESIGHTING WHITE LIGHT/INFRARED SEARCHLIGHT

STEP	PROCEDURE
	<p><b>WARNING:</b> <u>DO NOT look into searchlight beams. Serious eye damage can result.</u></p>
1	<p>Start vehicle engine and run at fast idle (table 2-3 or 2-4. 1).</p> <p><b>CAUTION:</b> <u>DO NOT operate searchlight without engine running.</u></p>
2	<p>Select a target (preferably a boresight panel) as near 1, 200 meters as possible.</p>
3	<p>With all superelevation removed from fire control system, lay aiming cross of M119 telescope on center of boresight panel. Center the bubble on the elevation quadrant with the micrometer knob.</p>
4	<p>Apply plus 5 mils on elevation 'quadrant and manually elevate gun until bubble is centered.</p>
5	<p>Place searchlight main control box LOCAL/REMOTE switch (10, fig. 2-36) in LOCAL position.</p> <p><b>NOTE.</b> <u>When switch is in REMOTE position. commander has control of searchlight with his remote control box.</u></p>
6	<p>Turn BEAM SPREAD/COMPACT switch (7, fig. 2-36) to COMPACT position.</p>
7	<p>Turn VISIBLE/INFRARED/OFF switch (9, fig. 2-36) to VISIBLE position. Green LAMP ON light (8, fig. 2-36) and searchlight will ignite.</p>
8	<p>Loosen 4 screws (2, fig. 2-35) securing searchlight to support.</p>
9	<p>Align searchlight until maximum intensity of searchlight beam is horizontally on center of boresight panel and tighten 4 screws.</p>
10	<p>Back off the 2 jam nuts (4, fig. 2-35) on the elevating adjusting screw (6, fig. 2-35).</p>
11	<p>Turn adjusting screw (6, fig. 2-35) and raise or lower searchlight until beam is vertically on boresight panel Tighten 2 jam nuts (4, fig. 2-35).</p>
12	<p>Tighten Jack screw (8, fig. 2-35) firmly against gun shield and lock with jam nut (7, fig. 2-35).</p>
13	<p>Turn VISIBLE/INFRARED/OFF switch to OFF position.</p> <p><b>CAUTION:</b> <u>DO NOT shut VEHICLE MASTER switch off until after searchlight thermostatically controlled blower motor has stopped.</u></p>
<p><b>ALTERNATE METHOD (REFER TO FIG. 2-37)</b></p>	
14	<p>Position the tank so the searchlight is facing a vertical surface such as a wall at a distance of approximately 10 meters (30 feet).</p>
15	<p>Place a cross on the vertical surface approximately 7 feet from the ground and a second cross 16-1/2 inches above, and 20-41/64 inches left of the first cross.</p>
16	<p>Remove all superelevation from fire control system and place boresight thread on muzzle end of gun tube and boresight main gun on lower cross (table 2-9).</p>

TABLE 2-16. BORESIGHTING WHITE LIGHT/INFRARED SEARCHLIGHT - CONTINUED

STEP	PROCEDURE
<b>ALTERNATE METHOD (REFER TO FIG. 2-37) - CONTINUED</b>	
17	Adjust searchlight (steps 5 through 10) until light beam is centered on upper cross. Place a reference mark so that top edge of mark just touches the bottom of searchlight beam. Center the bubble on the elevation quadrant using the micrometer knob.
18	With searchlight on, apply 5 mils on elevation quadrant and manually elevate gun until bubble is centered.
19	Adjust searchlight (steps 9 and 10) until bottom of light beam is above and just touching the reference mark. This technique will converge the light beam and the axis of the gun at approximately 1,200 meters.
20	Follow steps 12 and 13 above.

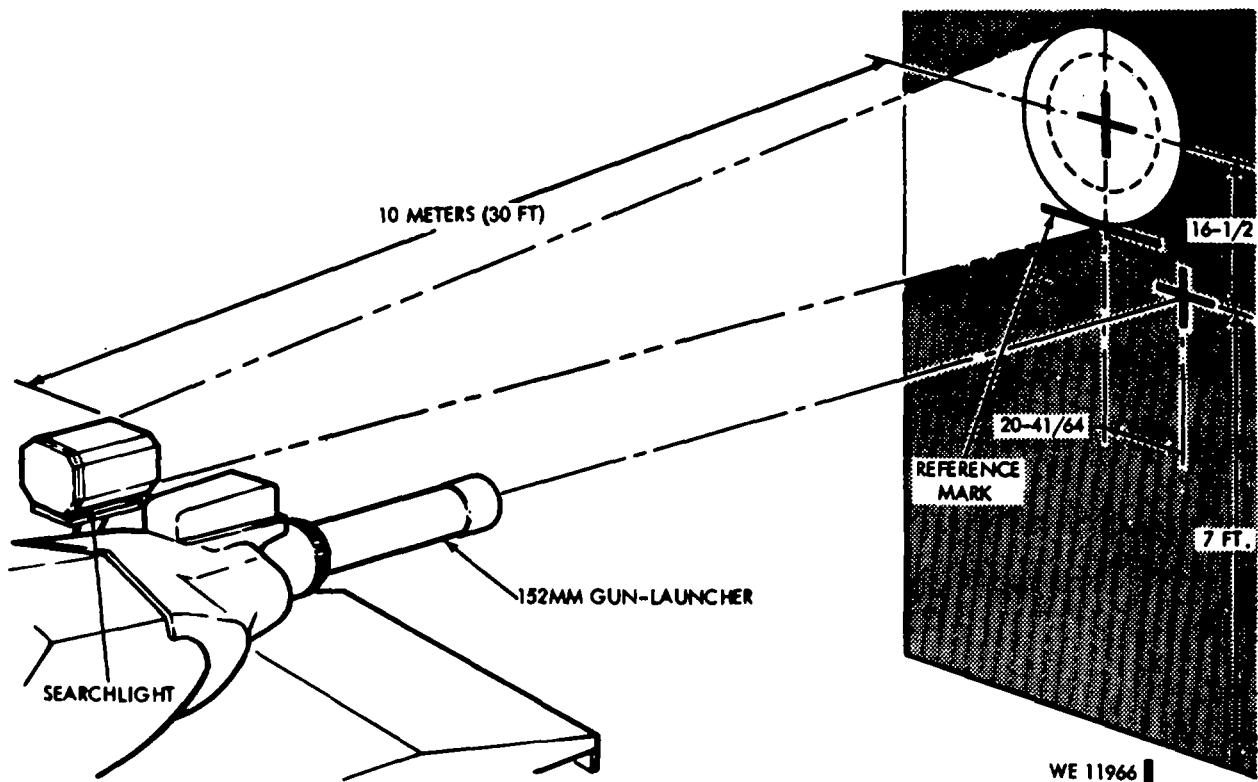

Figure 2-37. (Added) Searchlight boresight target.

## CHAPTER 3 FIRING PROCEDURE

### Section 3-1. MISFIRE, HANGFIRE, AND COOK-OFF, AND IMMEDIATE ACTION IN CASE OF FAILURE TO FIRE

#### 3-1. MISFIRE, HANGFIRE, AND COOK-OFF CONVENTIONAL AMMUNITION

a. Conditions described below are rarely encountered when authorized, properly maintained ammunition is fired in properly maintained and operated weapons. To avoid injury to personnel and damage to equipment, however, it is important that those concerned understand the nature of these conditions and be familiar with preventive and corrective procedures.

**WARNING:** In event of failure to fire, keep weapon trained on target. Have personnel stand clear of muzzle and path of recoil. Chambered rounds should be fired or removed from weapon within five minutes. In case of an explosive round chambered in a hot weapon, which can neither be fired nor removed within five minutes, evacuate personnel from area for period of two hours.

- (1) Misfire. A misfire is a failure of a round to fire after initiating action is taken. The failure may be due to a faulty firing mechanism or a faulty element in the propelling charge explosive train. A misfire in itself is not dangerous; however, it cannot be immediately distinguished from a delay infuncting of the weapon firing mechanism or from a hangfire. Misfires must be treated as delayed firings, therefore, until otherwise determined.
- (2) Hangfire. A hangfire is a delay in the functioning of a propelling charge explosive train at the time of firing. The delay, though unpredictable, ranges from a fraction of a second to several minutes. A hangfire cannot be distinguished immediately from a misfire.
- (3) Cook-off. A cook-off is a functioning of any or all of the explosive components of a round chambered in a hot weapon. If the primer or the propelling charge should cook-off, the projectile may be fired from the weapon with normal velocity even without attempting to fire the primer by actuating the firing mechanism. Should the bursting charge explosive train cook-off, injury to personnel and destruction

of the weapon may result.

b. After failure to fire, observe following precautions until round has been removed from weapon:

- (1) Keep weapon trained on target, and all personnel clear of muzzle and path of recoil.
  - (2) Make two additional attempts to fire.
  - (3) Wait two minutes after third attempt to fire. Open breech. Clean firing probe. Close breech.
  - (4) Attempt to fire again.
  - (5) If weapon is hot and round cannot be removed within five minutes, elevate weapon to approximately 19 degrees and evacuate all personnel from area. Wait two hours.
- NOTE.** After waiting period, weapon may be carefully relocated to a remote position. To relocate, lower cannon tube and engage traverse lock.
- (6) Request EOD or direct support ammunition maintenance personnel to remove round or cannon with round.
  - (7) If removed round is determined to be at fault, or was removed from hot cannon, set it aside for disposal by authorized munitions personnel.
  - (8) Have firing mechanism corrected, if at fault. After mechanism is corrected, round may be reloaded and fired.

**CAUTION:** Do not reuse rounds extracted from weapons by ramming. Extraction difficulty may have been caused by some nonstandard condition in the ammunition; also, the fuze may have been damaged during ramming process.

c. Observe the following safe temperature limits when loading or firing conventional ammunition:

For all models except HE-T cartridge XM657E2:  
Upper limit..... +125°F  
Lower limit..... -40°F

For HE-T cartridge XM657E2 only:  
Upper limit..... +125°F  
Lower limit..... +40°F

d. Observe the following precaution relative to duds:

**WARNING:** Do not touch, move or otherwise handle duds. Notify EOD of location.

**3-1.1. Misfire, Hangfire, Cook-Off, and Stoppage - Cal. .50 and 7.62MM Machine Guns**

a. Misfire. A misfire is a complete failure to fire. It must be treated as a hangfire until such possibility has been eliminated.

b. Hangfire. A hangfire is a delay in the functioning of a propelling charge. The time interval prescribed in table 3-2 will be observed after a failure to fire.

c. Cook-Off. A cook-off is the firing of the chambered round due to the heat of a hot barrel and not due to the actuating of the machine gun.

d. Stoppage. Stoppage is any interruption in the cycle of operation caused by faulty action of the machine gun of ammunition.

**3-2. Immediate Action In Case of Failure to Fire**

- 152MM Gun/Launcher - Table 3-1.
- 7.62MM Machine Gun - Table 3-2.
- Cal. 50 Machine Gun - Table 3-3.
- Missile- ----- Table 3-4. 1.

**3-2. 1 SHILLELAGH MISSILE**

a. Firing temperature limits for the SHILLELAGH missile are +1450F to -250F.

b. Loading, launching, and unloading procedures are contained in table 3-4. 1.

c. The M29 and M29A dummy missiles simulate the SHILLELAGH missile in size, weight, center of gravity, and "feel" The dummy missile is completely inert and contains no explosives. It is provided as a "drill" round for training in loading the SHILLELAGH missile into the gun-launcher.

TABLE 3-1. IMMEDIATE ACTION IN CASE OF FAILURE TO FIRE -  
152MM CONVENTIONAL AMMUNITION

STEP	PROCEDURE	FIG/ITEM
1	<p>Attempt to fire with firing button on elevation handwheel.</p> <p><b>WARNING:</b> <u>Remove blasting machine from bracket and operate from loader's or commander's seat. If blasting machine must be operated in bracket, be careful to stand clear of gun recoil.</u></p>	2-19
2	<p>Attempt to fire 152MM conventional round (third time) by removing safety pin and turning blasting machine handle vigorously 3 to 5 times.</p>	3-1/F
3	<p>Push SAFE/READY switch to SAFE position if third attempt to fire fails</p> <p><b>CAUTION:</b> <u>Wait at least 2 minutes after step 3, remaining clear of breech in case round ignites and gun-launcher recoils.</u></p>	3-1/A
4	<p>Place ejector lever in non-eject (up) position</p> <p><b>CAUTION:</b> <u>Make certain ejector lever is in non-eject (up) position before opening the breech. If in eject position, the ejector would cut open case upon breech opening allowing propellant particles to escape into turret, creating an extremely hazardous condition.</u></p>	3-1/D
5	<p>Open breech electrically or manually (table 3-4).</p>	
6	<p>Depress release handle located at forward edge of loading tray bracket, and hold in depressed position. If only one man is available to remove round, insert a small (3/16") piece of wood between loading tray detent release plunger and housing assembly detent release pin, and completely open breech chamber. The wood will permit use of both hands to remove round.</p>	3-1/D
7	<p>Grasp round and slide rearward onto loading tray</p>	3-1/E
8	<p>Release detent release handle and return round to rack</p>	3-1/D
9	<p>Return round to ammunition personnel as soon as possible for disposition.</p>	
10	<p>Before resuming firing procedure after misfire, check firing probe contact and clean if necessary to assure proper operation.</p>	3-1/E
11	<p>Report misfires, hangfires, and other malfunctions in accordance with unit safety SOP.</p>	



TABLE 3-2. IMMEDIATE ACTION IN CASE OF FAILURE TO FIRE - 7.62-MM MACHINE GUN,

STEP	PROCEDURE	FIG/ITEM
	<b>COOL WEAPON</b>	
	When a stoppage occurs (failure to fire) before completing a 200-round series (starting from a cool machine gun), perform the operations listed below.	
1	Wait five seconds in the event of hangfire.	
	<b>WARNING:</b> <u>Keep weapon trained on target.</u>	
2	Charge weapon fully (if possible) to sear position and attempt to fire next round (table 3-5).	3-5/D
3	If the weapon fails to fire, charge weapon again and place safety in S (safe) position.	3-5/E
4	Open cover assembly and remove belted ammunition.	3-5/F
5	Open feed tray and remove live ammunition or spent cartridge and links from weapon chamber and/or immediate area.	3-5/E
6	Slide safety into F (fire) position and hand-function weapon one cycle.	3-5/E
7	Load and attempt to fire, if weapon still fails to function properly, inspect for cause of stoppage, refer to troubleshooting procedure (table 5-1, steps 32 through 42).	
	<b>HOT WEAPON</b>	
	When stoppage occurs (failure to fire), after a burst of approximately 200 rounds fired either spasmodically or continuously within two minutes, perform the operations listed below.	
	<b>WARNING:</b> <u>The danger of an open-cover cook-off exists when weapon is hot. Immediate action must be applied within 10 seconds. Keep weapon trained on target, remain clear of barrel and do not open cover during this period.</u>	
8	Follow steps 1 and 2 above.	
9	If firing cannot be resumed, charge weapon to sear position and slide safety to S (safe) position.	3-5/E
	<b>WARNING:</b> <u>Allow the weapon to cool at least five minutes before attempting to open cover assembly.</u>	
10	Open cover, clear and inspect weapon for cause of stoppage; refer to troubleshooting procedure (table 5-1, steps 32 through 42).	
	3-2.2 (Pages 3-2. 3 and 3-2. 4 Deleted)	

TABLE 3-3. IMMEDIATE ACTION IN CASE OF FAILURE TO FIRE-CAL..50 MACHINE GUN M42,HB

STEP	PROCEDURE	FIG/ITEM
<p>1</p> <p>2</p> <p>3</p> <p>4</p> <p>5</p> <p>6</p> <p>7</p> <p>8</p> <p>9</p> <p>10</p> <p>11</p>	<p style="text-align: center;"><b>COOL WEAPON</b></p> <p>When a stoppage occurs (failure to fire) before completing 150 rounds, perform operations listed below.</p> <p>Wait 5 seconds in the event of a hangfire.</p> <p><b>WARNING:</b> <u>Keep weapon trained on target.</u></p> <p>Retract bolt and push retracting slide handle forward.</p> <p>Depress bolt latch release to return bolt to battery position.</p> <p>Depress trigger and attempt to fire.</p> <p>If weapon still fails to fire, wait 5 seconds, retract bolt (engage with bolt latch) and return handle forward.</p> <p><b>NOTE:</b> <u>If bolt latch release is in a locked (depressed position), the bolt will be forward and another round could be chambered.</u></p> <p>Open cover assembly and remove belted ammunition</p> <p><b>WARNING:</b> <u>Inspect to insure weapon is clear.</u></p> <p>Check to determine cause of stoppage; refer to troubleshooting procedure (table 5-1, steps 43 through 49).</p> <p style="text-align: center;"><b>HOT WEAPON</b></p> <p>When stoppage occurs (failure to fire) after firing approximately 200 rounds, either spasmodically or continuously within 2 minutes, perform the operations listed below:</p> <p><b>WARNING:</b> <u>The danger of a cook-off exists when barrel is hot. Immediate action must be applied within 10 seconds. Keep weapon trained on target, remain clear of barrel and do not open cover during this period.</u></p> <p>Follow steps 1 and 2 above.</p> <p>Attempt to fire by depressing bolt latch release and trigger at same time. Weapon should fire automatically.</p> <p>Follow steps 5 through 7 above.</p> <p>If the bolt cannot be retracted when applying immediate action or a misfire occurs after intentional cessation of firing and bolt is forward at time trigger is pressed, the bolt must remain locked in battery position (do not open the cover assembly). <b>ALLOW THE WEAPON TO COOL AT LEAST 5 MINUTES</b> to guard against a cook-off. After waiting specified time (5 minutes), follow steps 1 through 7 above.</p>	<p></p> <p>3-8/E</p> <p>3-8/D</p> <p>3-8/F</p> <p>3-8/F</p> <p></p> <p>3-8/B</p> <p></p> <p></p> <p>3-8/D</p> <p></p>
	<p>3-3</p>	

## Section 3-2. 152MM GUN-LAUNCHER

**3-3. Firing Procedure**

The following table and illustrations provide 152MM gun-launcher conventional ammunition and missile firing procedure.

**NOTE.** Before operation, the crew must be familiar with the location and operation of all controls (figs. 2-19, 20, 23, 25 and 3-r through S-4).

**3-3.1. Deleted.****3-3.2. Closed Breech Scavenging System**

a. M551 vehicles equipped with M81EI gun/launcher incorporate a closed breech compressed air scavenging system. The system is used with both missile and conventional ammunition to scavenge breech and gun tube of debris and gases.

b. The system consists of a four-stage air compressor, two air cylinders, pressure gage, pressure regulator, on-off switch, solenoid discharge valve with manual discharge lever, and attaching hoses and fittings.

c. Compressor operation is automatically controlled by a pressure control switch which energizes the compressor motor when pressure in the system falls below 2800 (+100) psi, and de-energizes compressor motor when pressure reaches 3100 (+100) psi. An electrical interlock prevents operation of the compressor when selector control is in missile mode, to avoid possible voltage drop in the vehicle electrical system during launching and tracing.

d. Air (regulated to 630 psi regardless of system pressure) is discharged into the closed

breech cavity when gun returns to battery and contacts the in-battery limit switch. A delay of 1.7 seconds before the breech opens provides time required for the scavenging blast. The pressure gage indicates pressure in the system, in psi and number of rounds remaining without further compressor operation.

e. Operation of the system is explained in figures 3-2.3 and 3-2.4. Preventive maintenance checks and services are covered in table 4-1.

**3-3.3. High Voltage Power Supply for Conventional Mode Firing**

A high voltage power supply provides a -120 volt pulse when firing the gun-launcher in conventional mode to eliminate the possibility of a misfire due to firing probe or ammunition contamination. When the FIRE CONTROL selector is in CONV position, the +28 volt vehicle power to the firing probe is interrupted and the -120 volt power supply is energized. When the firing trigger is squeezed the 120 volt electrical pulse is sent to the firing probe.

**3-3. 4. Ammunition Detent Identification**

a. The ammunition detent assembly which is referred to as "early design" is Type I detent assembly; the "late design" is Type H detent assembly.

b. The Type m detent assembly is identified in one or all of the following manners:

(1) The designation "Type II" stamped on face of detent housing cover.

(2) Type m detent shaft has a smaller diameter (1/4-inch) than Type I and II detent shafts (3/8-inch).

(3) Decal positioned above detent assembly stating "TYPE 3 AMMUNITION DETENT INSTALLED".

TABLE 3-4. LOADING, FIRING, AND UNLOADING 6UN-LAUNCHR WITH CONVENTIONAL ROUND

STEP	PROCEDURE	FIG/ITEM
	<p><b>WARNING:</b> <u>Do not chamber ammunition until immediately before firing. Ammunition left too long in a hot weapon may result in hazardous conditions. fire or remove ammunition within five minutes of chambering. Refer to Section 7-2 for instructions and warnings on handling ammunition before proceeding to fire.</u></p> <p style="text-align: center;"><b>PREPARATION FOR FIRING</b></p>	
1	Perform before-operation preventive-maintenance checks and services (table 4-1, steps 21, 22, 23 and 45 through 52).	
2	Check safe-to-fire indicator rod to be sure it is within safe range. 3-2	
3	Check recoil mechanism replenisher system reservoir for proper fluid level	3-2
4	Remove 152MM gun-launcher muzzle plug if installed.	1-1/4
5	Check boresight alignment of gun-launcher, 7. 62MM machine gun and sighting and fire control equipment (table 2-9). Be sure machine gun cover is closed and locked.	
6	Turn vehicle MASTER SWITCH on and start engine.	2-10
7	Turn TURRET CONTROL POWER switch on (non-stabilized mode), turn STAB switch on (if stabilized mode is desired) (par. 2-5).	
8	Turn FIRE CONTROL selector to CONV position. The corresponding lamp above the selector will illuminate.	2-19
9	Turn turret ventilating fan on.	2-20/E
	<p><b>NOTE:</b> <u>The turret fan motor circuit is interrupted when gun launcher leaves "in-battery" position (after a successful missile or conventional firing) and remains interrupted until the completion of scavenging cycle.</u></p>	
9.1	On vehicles with CO <sub>2</sub> scavenging system, remove bottle valve safety pin and secure operating handle in open position with clip. Weigh CO <sub>2</sub> bottle after firing every ten (10) rounds.	3-2.2
9.2	On vehicles equipped with closed breech scavenging system, make sure shut-off valve is open (handle parallel to valve), and turret selector switch is on "CONV". Turn compressor switch ON; compressor should run if gage reads less than 2800 psi. Momentarily trip scavenger by means of lever on air solenoid valve to check operation of scavenger system.	3-2.4
	<b>OPENING BREECH ELECTRICALLY AND LOADING</b>	
	<p><b>CAUTION:</b> <u>Prior to loading, make sure tube, coupling, and breech chamber are clear do burning or smoldering residue.</u></p>	
10	Place loader's control box SAFE/READY switch in SAFE position.	3-1/A
11	Position breech actuator handle lever to engage one of 8 slots in rear cover.	3-1/B
12	Open breech by holding CLOSE/OPEN switch on loader's control box to OPEN position until breech is fully opened.	3-1/A
13	Remove round from stowage rack. Remove ballistic protective cover. Place round on loading tray. Remove neoprene barrier bag while loading round into gun tube. Shove round firmly into tube until detent pin is engaged.	3-1/E a 3-3
	<p><b>WARNING:</b> <u>Use only correct lots of ammunition and handle with care. Avoid striking fuze or primer. (Refer to Section 7-2)</u></p>	7-2, 3
14	Place ejector mechanism lever in non-eject (up) position.	3-/D

TABLE 3-4. LOADING, FIRING, AND UNLOADING GUN-LAUNCHER WITH CONVENTIONAL ROUND - CONTINUED

STEP	PROCEDURE	FIG/ITEM
15	<p><b>CAUTION:</b> <u>Make certain that ejector mechanism lever is in non-eject (up) position. and ERROR and ALIGN levers are in down (left) position.</u>            Close breech by holding CLOSE/OPEN switch on loader's control box to CLOSE position, until breech is fully closed.</p>	3-1/D 3-1/A
	<p><b>OPENING BREECH MANUALLY AND LOADING</b></p>	
16	Place loader's control box SAFE/READY switch in SAFE position.	3-1/A
17	Position breech actuator handle lever to engage slot in end of spindle visible at center of handle casting.	3-1/C
	<p><b>WARNING:</b> <u>Do not actuate breech electrically while breech actuator handle is engaged for manual operation.</u></p>	
18	Open breech by turning breech actuating handle counterclockwise until mechanical stop is reached.	3-1/C
19	Follow steps 13 and 14 above.	
20	Close breech by turning breech actuator handle in clockwise direction until contacting mechanical stop.	3-1/C
	<p><b>FIRING</b></p>	
21	Check safe-to-fire indicator rod to be sure it is within safe range.	3-2
22	Place SAFE/READY switch on loader's control box in READY position. Loader's and gunner's READY lamps will illuminate.	2-25 and 3-1/A
	<p><b>CAUTION:</b> <u>If lamps do not illuminate, refer to Troubleshooting Procedure (table 5-1, step 17).</u></p>	
	<p><b>WARNING:</b> <u>When firing, be alert to any evidence of smoke and/or flame from tube lock key or detent assembly vent. If this occurs, stop firing immediately and notify supporting maintenance.</u></p>	
	<p><b>WARNING:</b> <u>Personnel should remain clear of breech during recoil of gun-launcher. When more than normal complement of ammunition is to be fired-in rapid order, expansion of pressurized hydraulic fluid in reservoir may cause fluid to spray from pressure relief valve on top of reservoir. Check reservoir fluid level after every thirty rounds (fig 3-2).</u></p>	
	A. <u>Firing Gun-Launcher When Operating Turret Electrically.</u>	
23	Fire weapon by pressing trigger- on gunner's handle or depressing palm switch and pressing trigger on commander's handle.	2-19 and 2-21/9
	<p><b>NOTE:</b> <u>The scavenging system will automatically evacuate breech and gun -tube of gas and combustible case debris during recoil/battery cycle. On closed breech scavenging system, use manual discharge lever with breech closed.</u></p>	

TABLE 3-4. LOADING, FIRING, AND UNLOADING ,GUN-LAUNCHER WITH CONVENTIONAL ROUND - CONTINUED

STEP	PROCEDURE	FIG/ITEM
<b>FIRING -- Continued</b>		
B. <u>Firing Gun-Launcher When Operating Turret Manually.</u>		
24	Fire weapon by pressing firing button on gunner's manual elevation handwheel.	2-19
25	In case of power failure, fire round with blasting machine by twisting handle vigorously clockwise and holding in maximum clockwise position until weapon has fired.	3-1/F
<b>CAUTION:</b> Do not place SAFE/READY switch in SAFE position until breech is in the fully open position to prevent interruption of breech cycling. (Vehicle serial numbers 2 and 4 through 58).		
26	If additional rounds are required for firing mission, place loader's control box SAFE/READY switch in SAFE position after breech is fully open. Reload, close breech, then repeat firing procedure above.	3-1/A
<b>WARNING:</b> For immediate action in case of failure to fire, refer to Section 3-1 and table 3-1.		
<b>REMOVAL OF LIVE CONVENTIONAL ROUND</b>		
Refer to table 3-1.		
<b>AFTER FIRING</b>		
27	Place SAFE/READY switch on loader's control box in SAFE position.	3-1/A
28	Close breech electrically or manually.	
29	Turn FIRE CONTROL selector to OFF position.	2-19
30	Turn TURRET CONTROL POWER switch off if system is no longer required and engage turret traverse lock if vehicle is to be moved.	2-19 and 2-20/C
31	Turret ventilating fan may be turned off when clear of fumes.	2-20/E
32	On vehicles through. S/N699, release bore scavenging system CO2 bottle valve operating handle clip and install safety pin (closed' position).	3-2. 2
32.1	On vehicles after S/N699, turn compressor switch and air valve to OFF position.	3-1/A
33	Perform after-operation preventive-maintenance checks and services (table 4-1, steps 102, 103, 104, and 119 through 124).	
34	Clean and lubricate gun-launcher in accordance with table 5-8. 1.	
35	Stow nylon protective ammunition covers. Discard barrier bags.	3-3, 3-3.3
36	Install muzzle plug in gun-launcher muzzle to prevent entry of rain, dust, or debris.	
<b>3-6.1</b>		

TABLE 3-4.1. LOADING, LAUNCHING, AND UNLOADING MISSILES IN 152MM GUN-LAUNCHER

STEP	PROCEDURE	FIG/ITEM
<b>PREPARATION FOR LAUNCHING</b>		
1	Perform before-operation preventive maintenance checks and services (Table 4-1 steps 21, 22, 23, and 45 through 52).	
2	Check safe to fire indicator to be sure it is within operating range.	3-2
3	Check recoil mechanism reservoir for proper fluid level.	3-2
4	Remove gun-launcher muzzle plug if installed.	1-1/4
5	Turn vehicle MASTER SWITCH on and make certain all indicator and warning lights in turret are operative.	2-10
6	Check boresight alignment of gun-launcher and sighting and fire control equipment (Table 2-9). Close and lock cover of 7. 62mm machine gun.	
7	Energize missile sub-system and perform check procedures (Table 2-12).	
8	Turn on turret ventilating fan and open bore scavenger shut-off valve.	2-20/E 3-2.4
<p><b>WARNING</b> <u>If valve is not open, flareback may occur may occur after missile launching.</u></p>		
<p><b>NOTE</b> <u>In missile mode, closed breech scavenging system compressor does not operate. Therefore, make certain air bottles are at full pressure at beginning of launching operation. After several missiles have been fired, bottle pressure can be recharged by switching to "CONV" or "COAX" mode.</u></p>		
<b>LOADING AND LAUNCHING MISSILES</b>		
<p><b>CAUTION :</b> <u>Due to the design of Shillelagh missile, the following precautions should be followed: (1) Do not drop missile, (2) Do not strike missile, especially the warhead against any object that could dent or gouge the surface, especially the nose cone. To dent or gouge the surface could result in malfunction.</u></p>		
9	Turn and push TRANSMITTER DOOR control handle to open door, then turn handle clockwise to lock door open.	2-26/14
10	Place TURRET CONTROL switch located on gun and turret control selector to off position.	2-19
11	Place FIRE CONTROL switch on gun and turret control selector to off position.	
12	Place loader's control box SAFE/READY switch in SAFE position.	3-1/A
13	Start vehicle engine and set idle speed to at least 750 RPM.	
14	Place TURRET CONTROL switch in POWER position. Indicator light will illuminate. After approximately 20 seconds, TURRET CONTROL READY light will illuminate indicating turret control system and missile system power supply and rate sensors are energized and on standby.	
15	Turn FIRE CONTROL switch on gun and turret control selector to missile position. Indicator lamp will illuminate.	2-19

TABLE 3-4.1. LOADING, LAUNCHING, AND UNLOADING MISSILES IN 152MM GUN-LAUNCHER -Continued

STEP	PROCEDURE	FIG/ITEM
<b>LOADING AND LAUNCHING MISSILES - Continued</b>		
<p><b>NOTE</b> <u>Missile reticle appears in M119 telescope. PRIME VOLTAGE and POWER SUPPLY lamps on test checkout panel glow during warm-up period and GO OUT when sub-system is warmed up.</u></p>		
16	<p>Position breech actuator handle lever in one of eight slots in breech mechanism carrier cover.</p>	3-1/B
<p><b>WARNING</b> <u>Do not operate breech electrically with breech actuator handle lever engaged in spindle slot (Manual position). Personnel may be injured by spinning handle. Be sure handle lever is positioned in one of 8 slots in breech carrier cover.</u></p>		
17	<p>Place rear of ejector trigger lever on loading tray in eject (down position).</p>	3-1/D
18	<p>Open breech by holding CLOSE/OPEN switch on loader's control box until breech is fully open.</p>	3-1/A
19	<p>Remove missile from stowage rack, place on loading tray so that white index stripe on missile is facing up and firmly shove into breech until detent in gun-launcher breech coupling engages missile.</p>	3-1/E and 7-3
<p><b>WARNING</b> <u>Do not attempt to launch HEAT warhead missile with dented nose cone.</u></p>		
20	<p>Close breech by holding CLOSE/OPEN switch on loader's control box in CLOSE position, until breech is fully closed.</p>	3-1/A
<p><b>NOTE</b> <u>Breech mechanism may be operated manually. Place loader's control box switch in SAFE position and position breech actuator handle lever to engage slot in end of spindle visible at center of handle. Open breech by turning handle counterclockwise until breech is fully open. Close breech by rotating handle clockwise until breech is fully closed.</u></p>		
21	<p>Move loader's control box SAFE/READY switch from SAFE to READY position. Ready lamps on loader's control box and gunner's reticle dimmer box will illuminate.</p>	3-1/A
<p><b>WARNING</b> <u>When ready lamp on loader's control box is illuminated, weapon may be fired by gunner or commander. Personnel must be clear when gun-launcher recoils. After weapon returns to battery, breech will automatically open and missile cap will be ejected.</u></p>		
22	<p>Depress palm switch on gunner's control handle and track target through M119 or M127 telescope, using cross point in center of missile reticle.</p>	2-19 and 2-23/D



TABLE 3-4.1. LOADING, LAUNCHING, AND UNLOADING MISSILES IN 152MM GUN-LAUNCHER -Continued

STEP	PROCEDURE	FIG/ITEM
<b>LOADING AND LAUNCHING MISSILES -Continued</b>		
	<p><b>NOTE</b> 1. <u>Do not fire missile when terrain obstacles (within 500 meters of the vehicle and directly in line of flight) extend above the short horizontal mark below the center of the missile reticle (fig. 2-23D).</u></p> <p>2. <u>Vehicle must be stationary during missile firing.</u></p> <p>3. <u>The 12 power feature of the M127 telescope can be used to advantage at medium and extended ranges during night firings and in hazy weather conditions to obtain clearer target definition. Under all other conditions the eight power feature should be used.</u></p>	
23	<p>Launch missile by pressing gun-launcher firing trigger on gunner's control handle, and with palm switch depressed continue tracking target with control handle, keeping missile reticle on target until missile impact.</p> <p><b>WARNING</b> <u>After trigger is pressed there is a delay of 1 to 2-1/2 seconds before missile ignites and gun-launcher recoils. After counterrecoil, opening of breech will be delayed 1. 7 seconds while scavenging system is actuated.</u></p>	2-19 and 2-23/D
24	<p>When operating turret manually, track target with gunner's manual controls and launch missile by pressing firing button on elevation handwheel. Continue tracking target until missile impact.</p>	2-19
25	<p>After launching missile, and before reloading, place loader's control box SAFE/READY switch in SAFE position.</p>	3-1/A
<b>IMMEDIATE ACTION IN CASE OF FAILURE TO LAUNCH</b>		
26	<p>Attempt to launch (second time) with firing trigger on control handle.</p> <p><b>WARNING</b> <u>Do not attempt to launch missile with blasting machine.</u></p>	2-19
27	<p>Attempt to launch missile (third time) with firing button on elevation handwheel.</p>	2-19
28	<p>Move SAFE/READY switch to SAFE position if third attempt to launch fails.</p> <p><b>WARNING</b> <u>Wait at least 10 minutes remaining clear of breech in case missile ignites and gun-launcher recoils. (This wait may be reduced to 4 minutes under combat conditions).</u></p>	3-1/A
29	<p>Place ejector lever in non-eject (up) position.</p> <p><b>CAUTION</b> <u>Make certain ejector lever is in non-eject (up) position before opening breech. Ejector would attempt to eject whole missile and would be damaged.</u></p>	3-1/D

TABLE 3-4.1. ~~LOADING, LAUNCHING, AND UNLOADING MISSILES IN 152MM GUN-LAUNCHER~~ - Continued

STEP	PROCEDURE	FIG/ITEM
<b>IMMEDIATE ACTION IN CASE OF FAILURE TO LAUNCH - Continued</b>		
30	Open breech electrically or manually (steps 18 and 20).	
31	Depress detent release handle located at forward edge of loading tray bracket and hold in depressed position.	3-1/D
32	Grasp guided missile and slide rearward onto loading tray. <u>DO NOT TOUCH MISSILE FIRING CONNECTOR OR DIAPHRAGM.</u>	3-1/E
33	Release detent release. Remove missile from weapon.	3-1/D
34	<u>In combat situations</u> , dispose of missile immediately. <u>In non-combat situations</u> , cover the aft end of the missile with 2 layers of aluminum foil, extended over the rim of the aft cap, and secure the foil. Tag the missile with the following caution: "Misfired Missile Handle With Caution;" place missile in missile container; tag outside of container with the same caution, and evacuate through normal ammunition supply channels.	
35	Before resuming firing procedure after misfire, check firing mechanism contact and clean if necessary to assure proper operation.	3-1/E
36	Report misfires, hangfires, and other missile malfunctions in accordance with unit safety standard operating procedures.	
<b>AFTER FIRING</b>		
37	Place SAFE/READY switch on loader's control box in SAFE position.	
38	Close breech electrically or manually.	
39	Turn fire control selector to OFF position.	
40	Turn TURRET CONTROL POWER switch off as system is no longer required and engage turret traverse lock.	
41	Close transmitter door and turn handle to lock.	2-26/14
42	Turn turret ventilating fan off when vehicle is clear of fumes.	2-20/E
43	Close bore scavenger shut-off valve.	4-2
44	Perform after-operation preventive-maintenance checks and services (table 4-1, steps 102, 103, 104, and 119 through 124).	
45	Clean and lubricate gun-launcher in accordance with table 5-8. 1.	
46	Insert plug in gun-launcher muzzle to prevent entry of rain, dust, or debris.	

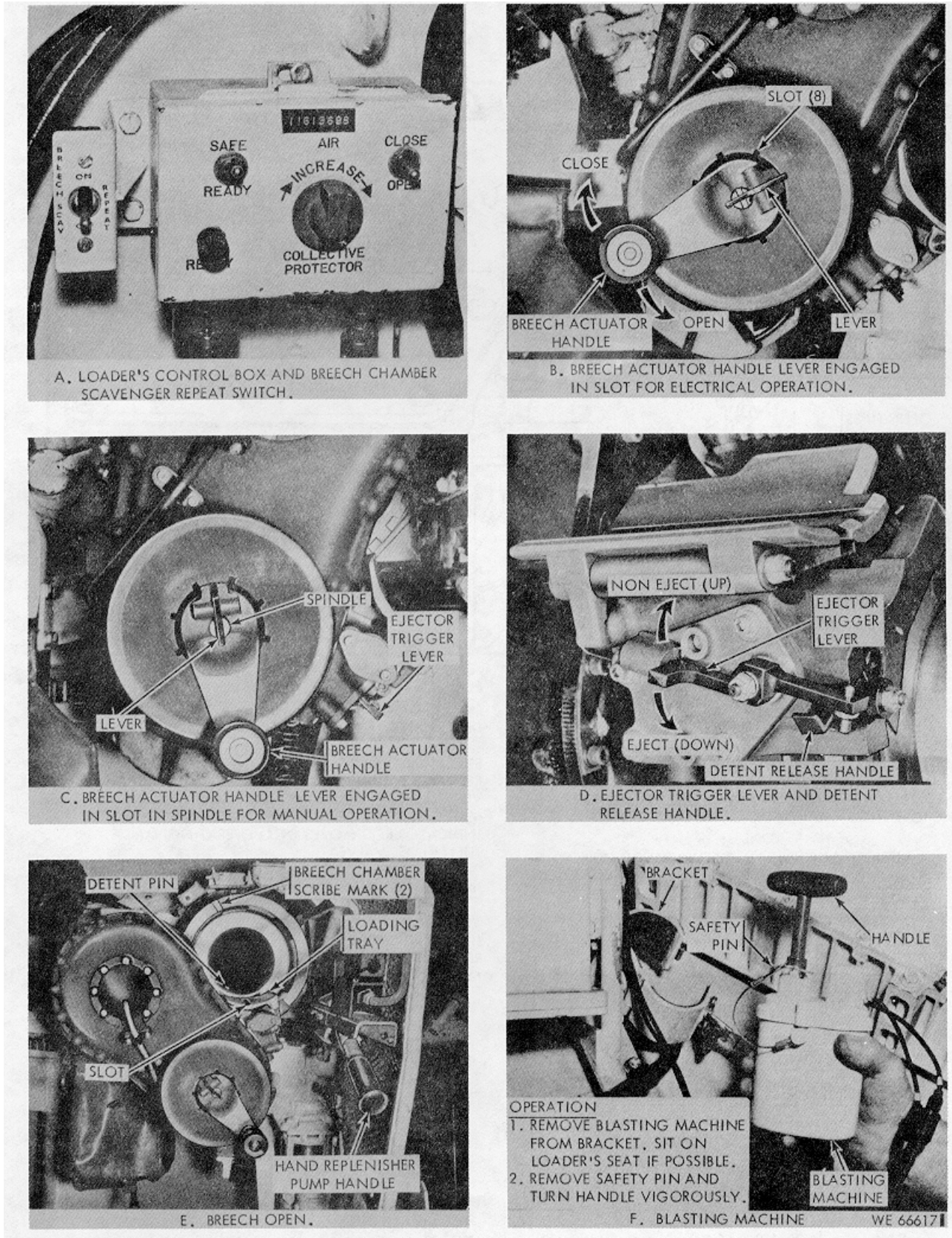
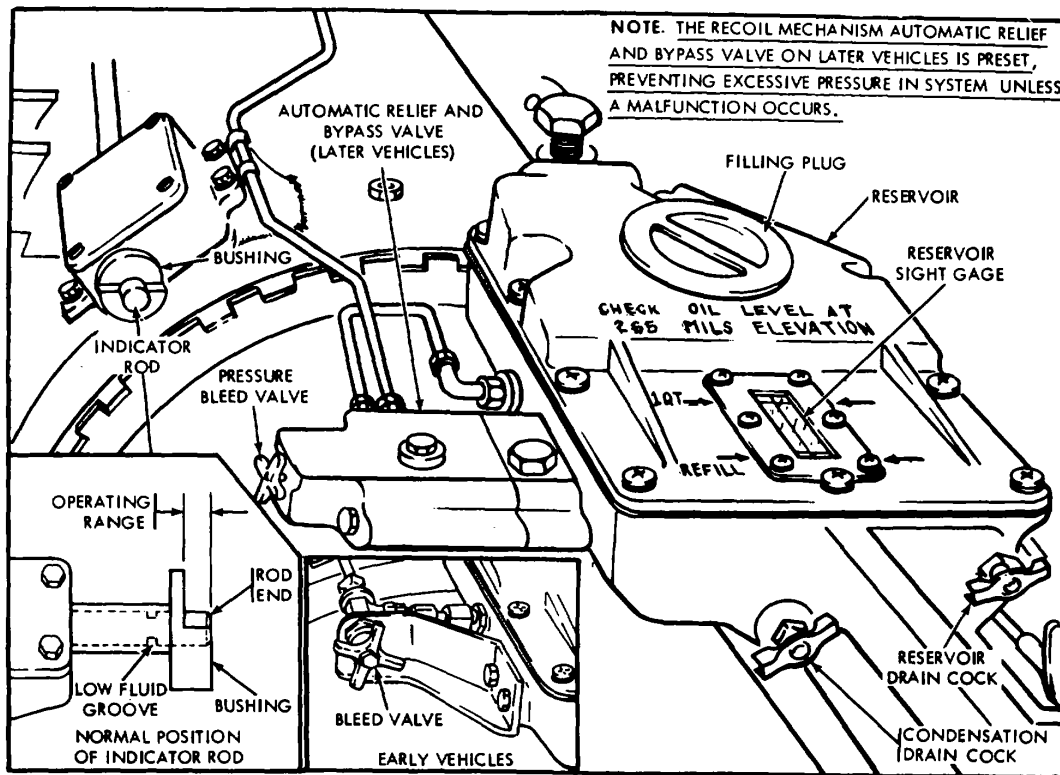

Figure 3-1. 152MM gun-launcher controls



CHECKING RESERVOIR FLUID LEVEL

WITH GUN/LAUNCHER ELEVATED TO 265 MILS, OBSERVE HYDRAULIC FLUID LEVEL IN RESERVOIR SIGHT GAGE. LEVEL MUST BE BETWEEN "REFILL" AND "1 QUART" CROSS LINES. ADD OR DRAIN FLUID AS REQUIRED.

**CAUTION:** WHEN ADDING FLUID, AVOID DAMAGING FLUID FILTER (IN FILL OPENING) WITH SPOUT OF FILLER CAN.

CHECKING HYDRAULIC PRESSURE

WITH GUN/LAUNCHER ELEVATED TO 265 MILS, CHECK POSITION OF INDICATOR ROD (SEE INSET). ROD MUST BE IN "OPERATING RANGE" TO RETURN GUN TO BATTERY.

**WARNING:** DO NOT FIRE IF LOW FLUID GROOVE PROTRUDES BEYOND END OF BUSHING, OR IF END OF ROD IS RECESSED INTO BUSHING. INCREASE OR DECREASE PRESSURE TO BRING ROD INTO OPERATING RANGE.

DECREASING PRESSURE

EXCEPT IN CASE OF AUTOMATIC VALVE MALFUNCTION, RELIEF OF HIGH PRESSURE IS AUTOMATIC ON LATER VEHICLES. ON EARLY VEHICLES (OR IN CASE OF VALVE MALFUNCTION) OPEN BLEED VALVE SLIGHTLY UNTIL INDICATOR ROD MOVES INTO OPERATING RANGE, THEN CLOSE VALVE.

INCREASING PRESSURE

ACTUATE HAND REPLENISHER PUMP HANDLE (E, FIG. 3-1) UNTIL INDICATOR ROD IS IN OPERATING RANGE. RECHECK RESERVOIR FLUID LEVEL, AS PREVIOUS CHECK MAY NOT BE ACCURATE IF PRESSURE WAS LOW.

**CAUTION:** IF RECOIL MECHANISM HAS BEEN DISASSEMBLED, OR IF GUN MOUNT HAS NOT BEEN EXERCISED RECENTLY, BELLEVILLE WASHERS IN RECOIL MECHANISM MAY NOT HAVE ATTAINED PROPER "SET", AND ROD MAY NOT RETURN TO OPERATING RANGE AFTER FIRING. CHECK ROD BETWEEN ROUNDS, USING HAND PUMP AS REQUIRED TO MOVE ROD INTO OPERATING RANGE FOR THE FIRST SEVERAL ROUNDS FIRED.

WE 66573

Figure 3-2. Checking and adjusting 152MH gun-launcher recoil mechanism

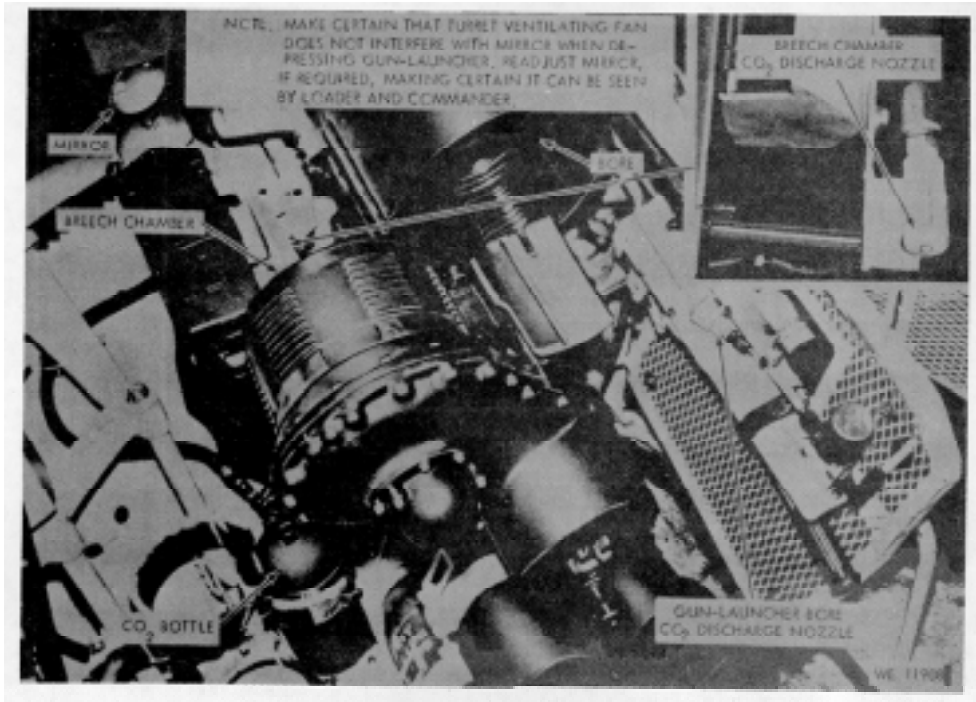

Figure 3-2.1. (Added) 152MM gun-launcher\_bore and breech chamber scavenging system

Figure 3-2.1.1.....Deleted

STEP	PROCEDURE
	<p>FULL CO<sub>2</sub> BOTTLE WEIGHTS VARY, THEREFORE, MAKE CERTAIN OF BOTTLE WEIGHT WHEN RECEIVED. IF NOT LEGIBLE, WEIGH BOTTLE AND RECORD WEIGHT</p>
	<p style="text-align: center;"><b>REMOVAL</b></p>
1	<p>RELEASE CLIP SECURING CO<sub>2</sub> BOTTLE CARRYING HANDLE IN THE VALVE HANDLE NOTCH (OPEN POSITION).</p>
2	<p>INSTALL SAFETY PIN TO SECURE VALVE HANDLE IN THE CLOSED POSITION.</p>
3	<p>OPEN BREECH AND BLEED OFF LINE PRESSURE BY PULSING THE LOADER'S BREECH CHAMBER SCAVENGE REPEAT SWITCH (A, FIG. 3-1) UNTIL LINE PRESSURE IS DEPLETED.</p>
	<p><b>CAUTION:</b> FAILURE TO BLEED OFF LINE PRESSURE WILL MAKE IT IMPOSSIBLE TO CONNECT PRESSURIZED LINES AT ASSEMBLY UNLESS FITTING ARE REMOVED. IF THIS IS NECESSARY, DO SO WITH CAUTION, KEEPING FACE AWAY TO PROTECT FROM CO<sub>2</sub> BLAST</p>
4	<p>SEPARATE HOSE QUICK-DISCONNECTOR FROM CO<sub>2</sub> BOTTLE ADAPTER</p>
5	<p>RELEASE RETAINING STRAP AND REMOVE BOTTLE FROM MOUNTING BRACKET.</p>
	<p style="text-align: center;"><b>WEIGHING</b></p>
6	<p>HOOK SCALE ONTO CO<sub>2</sub> BOTTLE VALVE AND WEIGH CONTENTS.</p>
	<p><b>NOTE:</b> REPLACE BOTTLE IF WEIGHT HAS DECREASED FOUR POUNDS OR MORE.</p>
	<p style="text-align: center;"><b>INSTALLATION</b></p>
7	<p>REMOVE SPARE CO<sub>2</sub> BOTTLE WITH ADAPTER FROM STOWAGE BRACKET AND INSTALL. REVERSE REMOVAL PROCEDURE, FOLLOWING STEPS 5, 4, 2, AND 1.</p>
8	<p>SECURE EMPTY BOTTLE IN SPARE STOWAGE BRACKET.</p>
	<p><b>NOTE</b> REMOVE HOSE ADAPTER FROM EMPTY CO<sub>2</sub> BOTTLE FOR USE ON REPLACEMENT BOTTLE AND TURN IN FOR REPLACEMENT AS SOON AS POSSIBLE.</p>

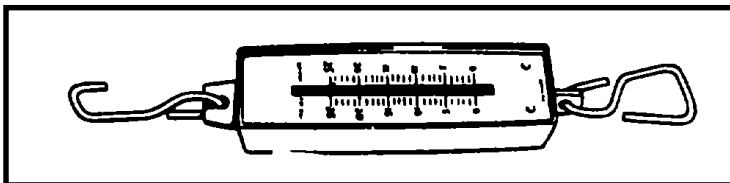
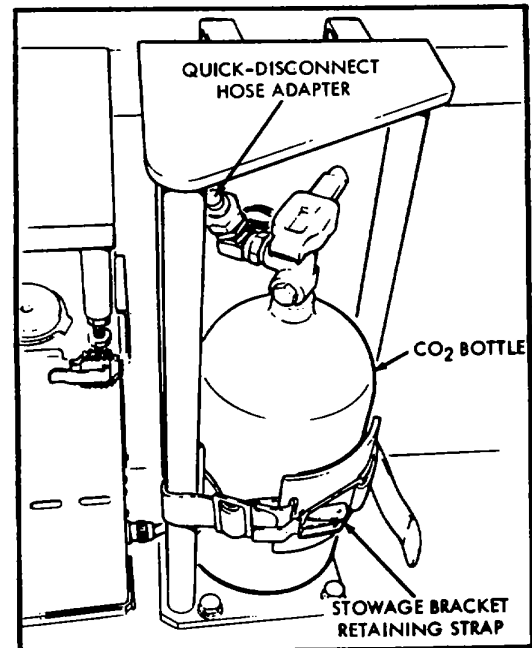
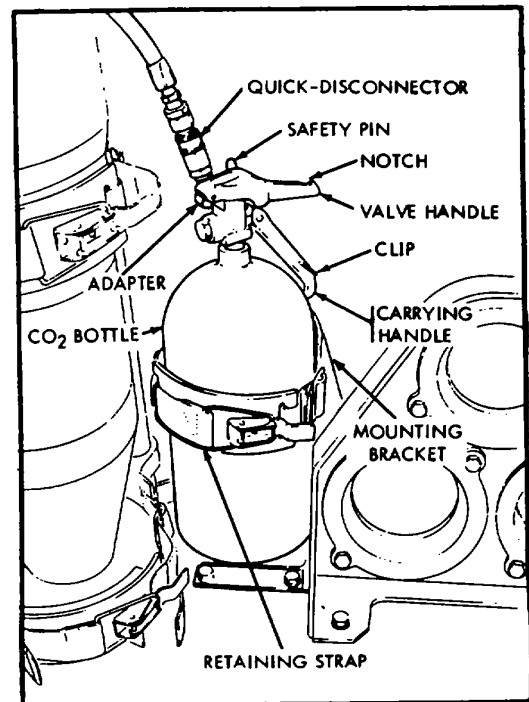
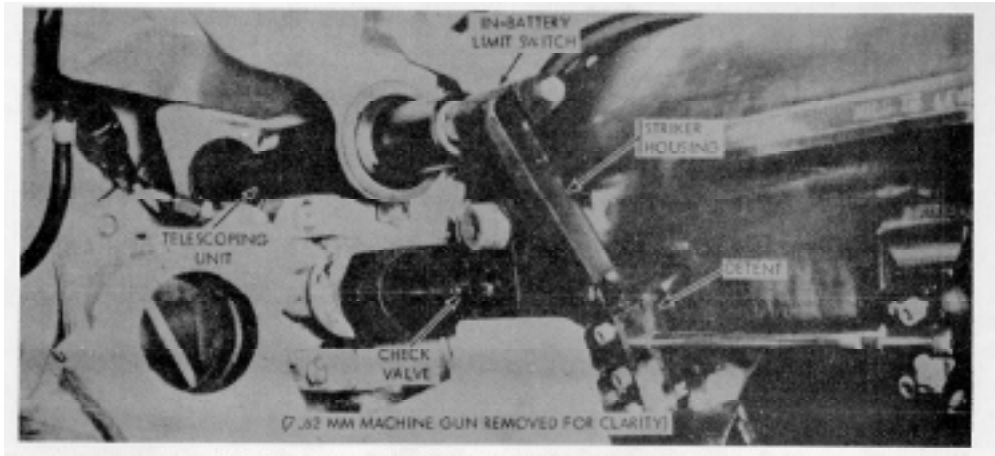

Figure 3-2.2. (Added) Removal/weighing/installation of gun-launcher bore and breech chamber scavenging system CO<sub>2</sub> bottle



CLOSED BREECH SCAVENGING GROUP ON GUN/LAUNCHER

M551 VEHICLES EQUIPPED WITH M81E1 GUN/LAUNCHER INCORPORATE A CLOSED BREECH SCAVENGING SYSTEM. (FOR DESCRIPTION OF THE SYSTEM, REFER TO PARAGRAPH 3-3.2).

OPERATING PROCEDURE

1. CHECK TO ASSURE THAT GUN/LAUNCHER IS CLEAR.
2. OPEN AIR SHUTOFF VALVE (FIG. 3-2.4).
3. START VEHICLE ENGINE AND SET THROTTLE AT FAST IDLE (TABLE 2-9).
4. TURN TURRET CONTROL POWER SWITCH "ON" AND GUN AND TURRET SELECTOR SWITCH TO "COAX" OR "CONV". (SCAVENGER SYSTEM OPERATES IN "MISSILE" MODE, BUT COMPRESSOR DOES NOT.)
5. TURN COMPRESSOR SWITCH "ON". COMPRESSOR SHOULD OPERATE IF PRESSURE IS LESS THAN 2800 (\*100) PSI, AND SHOULD SHUT OFF WHEN PRESSURE REACHES 3100 (\*100) PSI.

6. WITH PRESSURE ABOVE 630 PSI, MOMENTARILY ACTUATE MANUAL DISCHARGE LEVER (FIG. 3-2.4) TO CHECK OPERATION OF SYSTEM. (SINCE DISCHARGE PRESSURE IS REGULATED, OPERATION IS SAME AT ANY GAGE PRESSURE ABOVE 630 PSI.)

**NOTE: COMPRESSOR SHUTS DOWN FOR APPROXIMATELY 10 SECONDS EVERY 25-35 MINUTES TO DUMP ACCUMULATED MOISTURE. THIS IS NORMAL, NOT A MALFUNCTION.**

PRESSURE RECOVERY RATE

APPROXIMATE RECOVERY RATE, BASED ON COMPRESSOR OPERATING NORMALLY AND NO LEAKS IN SYSTEM, IS AS FOLLOWS:

0 - 800 PSI	27 TO 30 MINUTES
800 - 3100 PSI	70 MINUTES (33 PSI PER MINUTE)

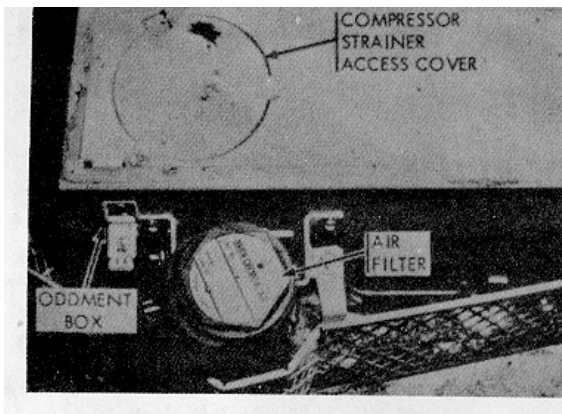

COMPRESSOR AIR FILTER AND ODDMENT STOWAGE BOX

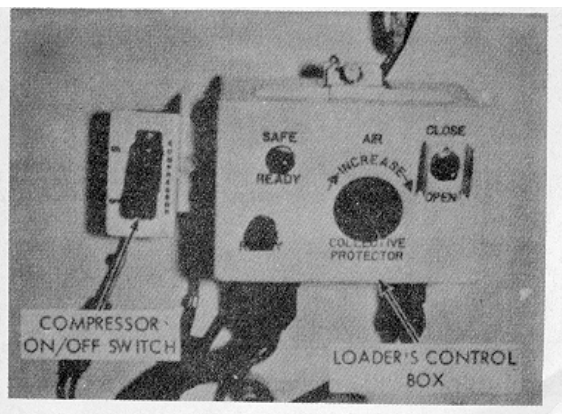

COMPRESSOR ON/OFF SWITCH

WE 120681

Figure 3-2.3. Closed breech scavenger system operation (1 of 2).

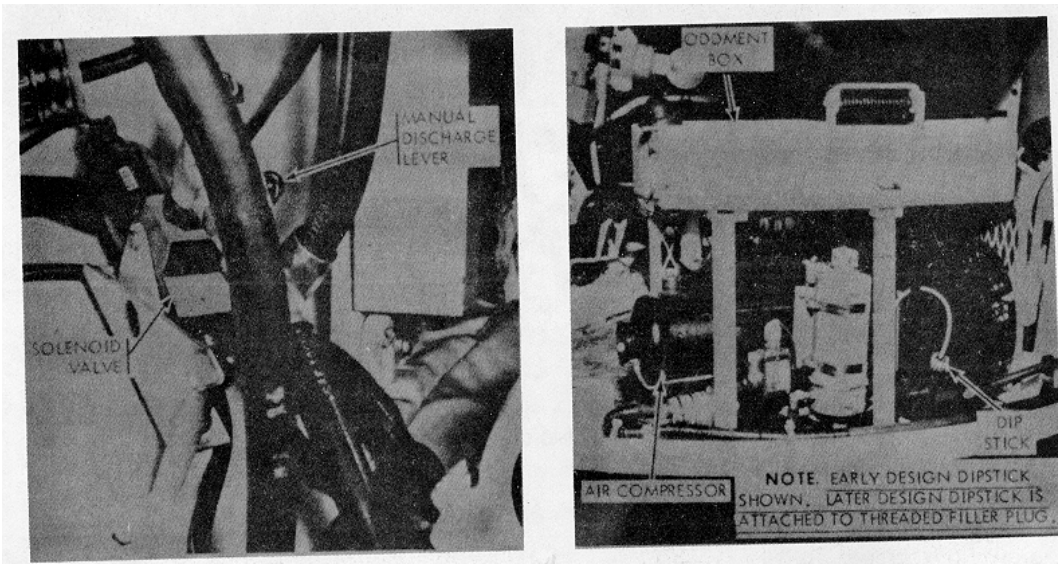

A. SOLENOID AND MANUAL DISCHARGE VALVE..

B. AIR COMPRESSOR

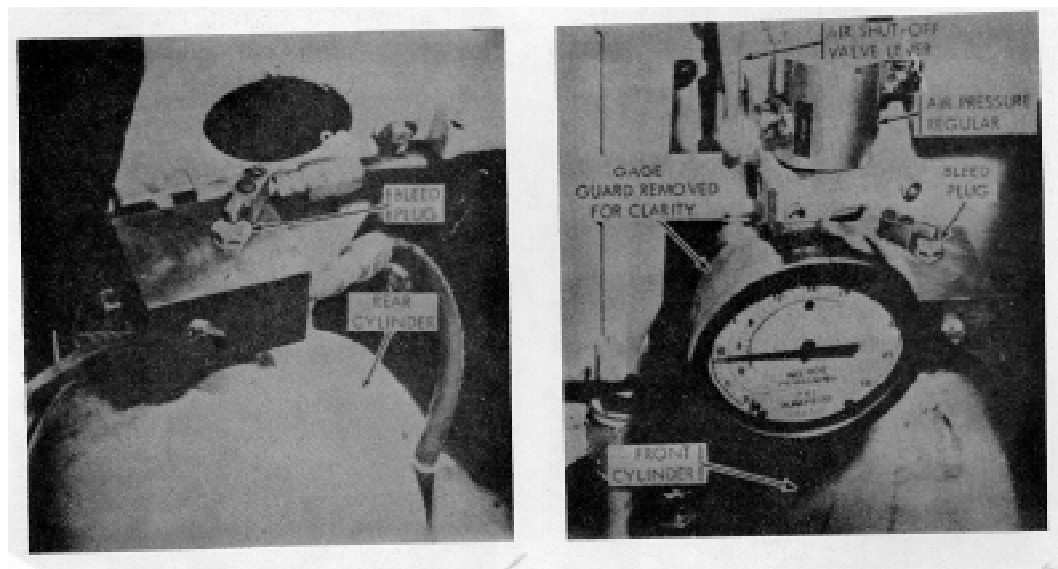

C. REAR CYLINDER BLEED PLUG.

D. FRONT CYLINDER BLEED PLUG.

Figure 3-2.4. Closed breech scavenger system operation (2 of 2).

WE 12069



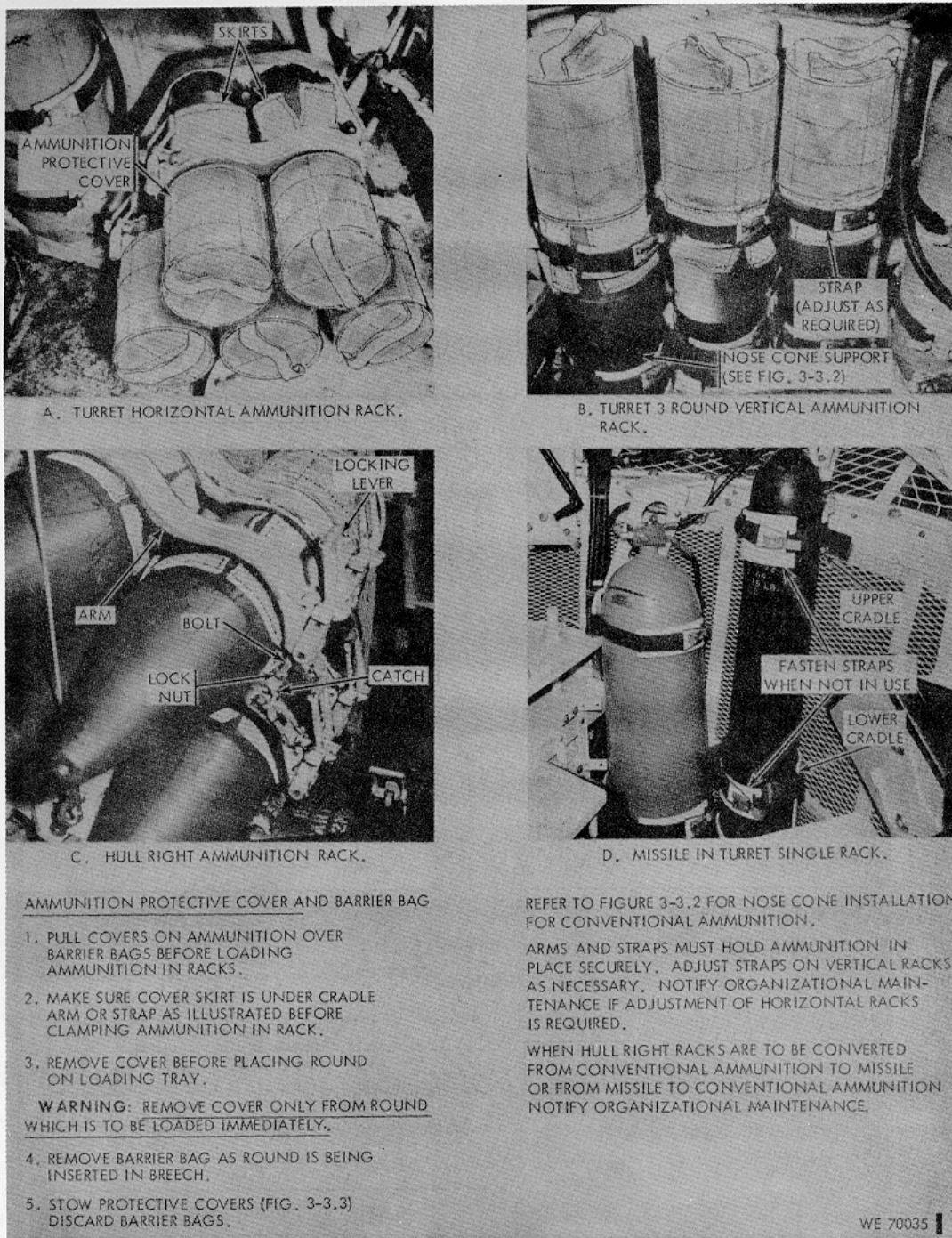

Figure 3-3. 152MM gun-launcher conventional ammunition and missile stowage

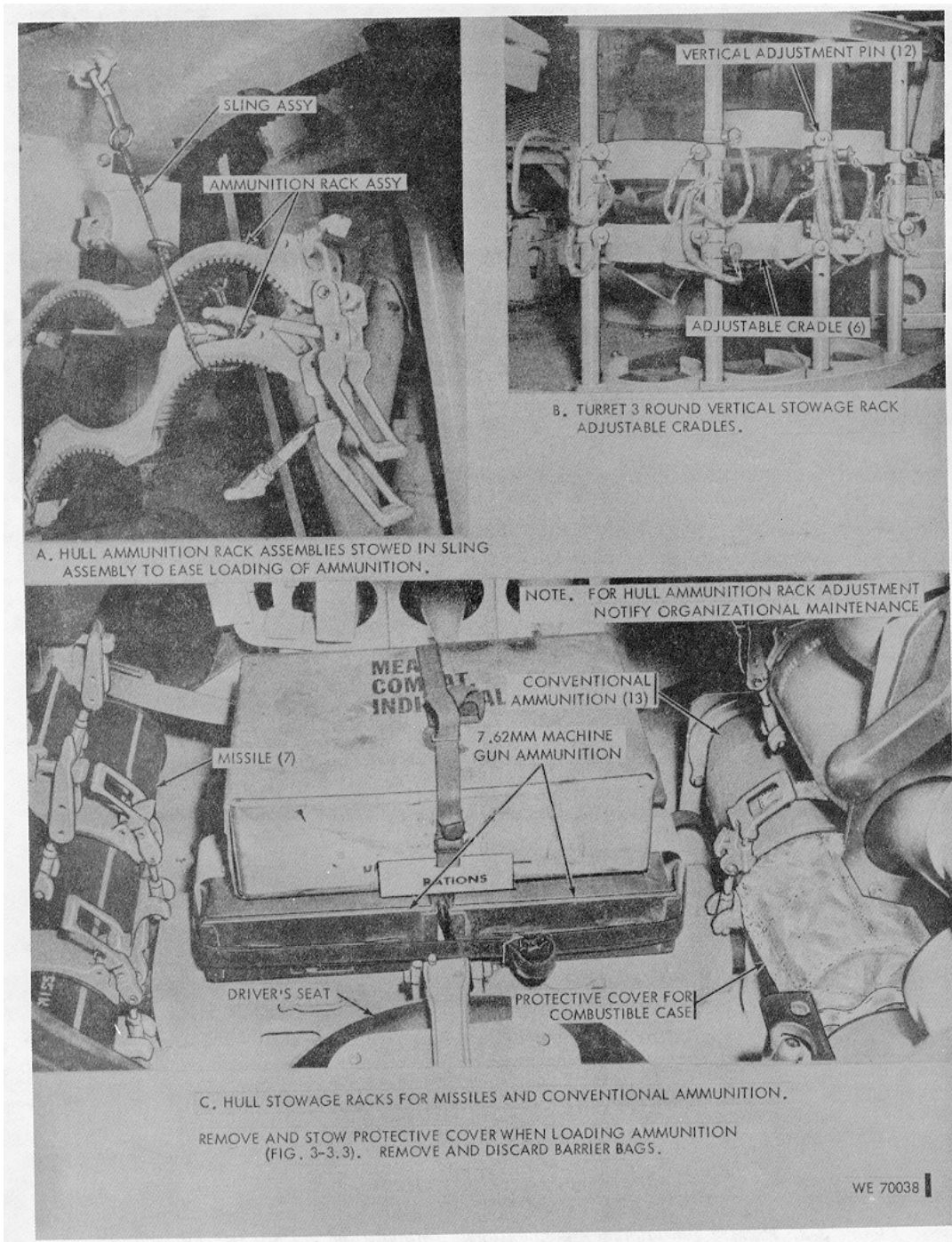
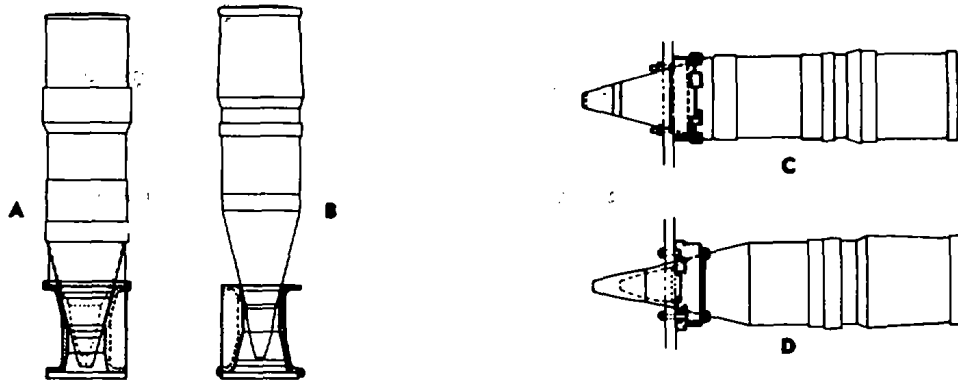

Figure 3-3.1. Turret 3 round vertical ammunition rack adjustment and hull ammunition stowage



- A. VERTICAL RACK NOSE CONE SUPPORT INSTALLED FOR XM409, XM411, XM625 AND XM657 AMMUNITION.
- B. NOSE CONE SUPPORT INVERTED TO FIT XM617 AMMUNITION.
- C. HORIZONTAL RACK NOSE CONE SUPPORT INSTALLED FOR XM409, XM411 AND XM625 AMMUNITION.
- D. NOSE CONE SUPPORT REVERSED TO FIT XM617 AND XM657 AMMUNITION.

REMOVAL/INSTALLATION FOR HORIZONTAL RACKS

REMOVE TWO NUTS AND SCREWS, REVERSE NOSE CONE SUPPORT, AND INSTALL USING SAME SCREWS AND NUTS.

REMOVAL/INSTALLATION FOR VERTICAL RACKS

LOOSEN STRAP, INVERT NOSE CONE SUPPORT AND FASTEN STRAPS.

NOTE. WHEN NOT IN USE, VERTICAL RACK NOSE CONE SUPPORTS ARE STOWED IN TURRET EXTERIOR RACK. WE 11958J

Figure 3-3.2. Reversible nose cone supports - conventional ammunition racks

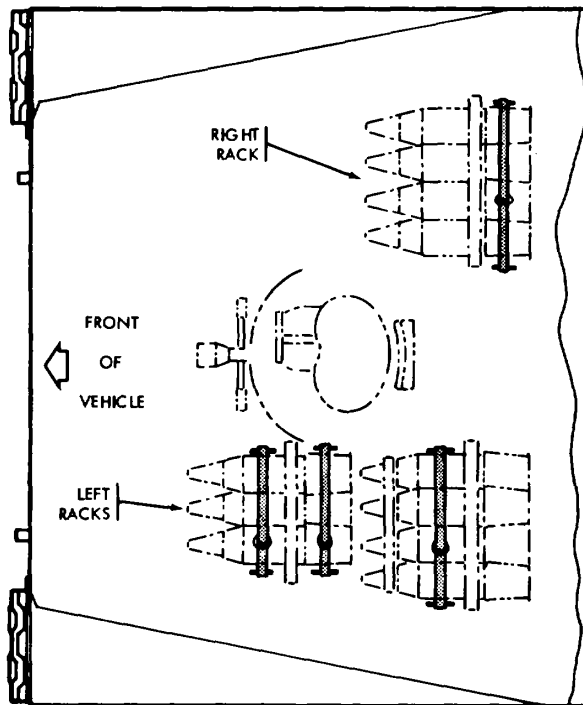

STOWAGE STRAPS ARE PROVIDED FOR STOWAGE OF AMMUNITION PROTECTIVE COVERS IN THREE PLACES BENEATH HULL LEFT AMMUNITION RACKS AND ONE PLACE BENEATH HULL RIGHT AMMUNITION RACK. ALL COVERS NOT IN USE ARE TO BE STOWED AT THESE LOCATIONS.

WITH NO AMMUNITION ON BOARD THE COVERS ARE STOWED 8 IN EACH OF THE LEFT RACK LOCATIONS AND 10 BENEATH THE RIGHT RACK. WITH FULL LOAD OF AMMUNITION (29 ROUNDS) THE SPARE COVERS ARE STOWED 1 IN EACH LEFT RACK LOCATION, AND 2 BENEATH THE RIGHT RACK.

WE 11962

Figure 3-3.3. Ammunition protective cover stowage (effective vehicle S/N 700)

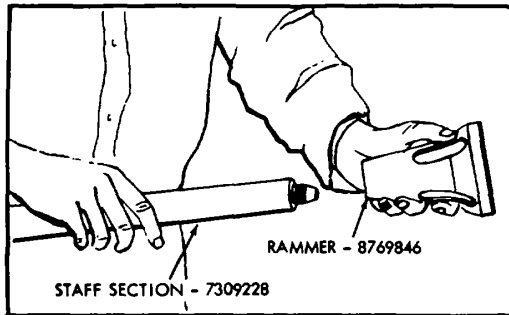

CONVENTIONAL ROUND REMOVAL PROCEDURE

**WARNING:** KEEP CLEAR OF MUZZLE, AND DO NOT HAMMER ROUND.

1. ASSEMBLE M15 CLEANING STAFF 7309228 TO RAMMER 8769846.
2. STATION SECOND CREW MEMBER IN TURRET TO DEPRESS DETENT RELEASE LEVER DURING RAMMING OPERATION, AND TO RECEIVE ROUND AS IT EMERGES FROM CHAMBER.
3. SLIDE STAFF ASSEMBLY GENTLY DOWN GUN-LAUNCHER BORE UNTIL SEATED ON OGIVE OF PROJECTILE. EXERT STEADY PRESSURE UNTIL ROUND IS CLEAR OF CHAMBER.

WE 66700 5

Figure 3-4. Removing a stuck conventional round from 152MM gun-launcher

**Section 3-3. 7.62MM MACHINE GUN**

**3-4. Firing Procedure**

The following tables and illustrations provide 7.62MM machine gun firing procedure.

**NOTE.** Before operation the crew should be familiarized with the location and operation of all controls (figs. 2-19, 20 and 3-5 through 3-7).

TABLE 3-5. *LOADING, FIRING, AND UNLOADING 7.62MM MACHINE GUN*

STEP	PROCEDURE	FIG/ITEM
<b>PREPARATION FOR FIRING</b>		
1	Perform before-operation preventive-maintenance checks and services (table 4-1, steps 53 through 55).	
2	Align machine gun with gun-launcher (table 2-9).	
3	Turn vehicle MASTER SWITCH on.	2-10
4	Make certain FIRE CONTROL selector is in OFF position.	2-19
5	Open ammunition feed box assembly door and load ammunition.	3-5/A
<b>LOADING AND CHARGING</b>		
6	Push forward on cover latch rod assembly and raise cover.	3-5/B
7	Raise feed tray and slide safety to F (fire) position.	3-5/C
8	Pull charger handle rearward and charge (cock) machine gun. Inspect chamber.	3-5/D
9	Slide safety to S (safe) position and lower feed tray. <b>WARNING:</b> <u>Make certain that feed tray is clear of live rounds, spent brass or links, barrel extension is in rearward position and safety is in S (safe) position.</u>	3-5/E
10	Place first round of ammunition belt in slot of feed tray with open end of 3-5/F link loops facing down.	
11	Assure that cover latch rod lock is engaged in forward position, then 3-5/B close cover.	

TABLE 3-5. LOADING, FIRING, AND UNLOADING 7.62MM MACHINE GUN, M73 - CONTINUED

STEP	PROCEDURE	FIG/ITEM
<b>FIRING ELECTRICALLY</b>		
12	Turn turret ventilating fan on. <b>WARNING:</b> <u>Without fan, toxic gases may reach dangerous level.</u>	2-20/E
13	Turn TURRET CONTROL POWER switch on.	2-19
14	Turn FIRE CONTROL selector to COAX position.	2-19
15	Slide safety to F (fire) position.	3-5/C
16	A. Firing Gun When Operating Turret Electrically. Depress palm switch and fire gun by pressing firing trigger on gunner's or commander's control handle.	2-19 and 2-21/9
	B. Firing Gun When Operating Turret Manually. Fire gun by pressing firing button on gunner's manual elevation hand-wheel.	2-19
	NOTE. To fire manually, press manual firing trigger on gun.	3-5/D
<b>UNLOADING UNFIRED ROUND</b>		
	<b>WARNING:</b> <u>For immediate action in case of failure to fire, refer to table 3-2.</u>	
<b>RUNAWAY GUN</b>		
	<b>NOTE:</b> <u>A runaway gun continues to fire after firing button is released.</u>	
	<b>CAUTION:</b> <u>Hold fire on target until feeding of ammunition is stopped.</u>	
17	Pull and hold charging handle to the rear to stop firing.	
18	Place safety in S (Safe) position and open cover, permitting ammunition link belt to drop out. <b>WARNING:</b> <u>Visually check and feel to assure that chamber is clear of ammunition.</u>	
18.1	Locate and correct cause (table 5-1). <b>REMOVAL OF RUPTURED CARTRIDGE CASE OR LIVE ROUND</b> <b>REMOVAL/INSTALLATION OF BARREL</b> <b>REMOVAL/INSTALLATION OF -FLASH HIDER</b> <b>REMOVAL/INSTALLATION OF MACHINE GUN</b> <b>AFTER FIRING</b>	3-6 5-11/12 5-13 3-7
19	Place gun safety in S (safe) position.	3-5/E
20	Turn FIRE CONTROL selector to OFF position.	2-19
21	Turn off turret ventilating fan.	2-20/E
22	Push forward on rear of cover latch rod assembly and open cover.	2-5/B
23	Remove ammunition belt from machine gun if ammunition has not been expended. <b>WARNING:</b> <u>If ammunition belt has been expended, inspect chamber for possible live cartridge, spent cartridge case, and/or empty link and remove.</u>	
24	Raise feed tray, slide safety to F (fire) position and pull charger handle rearward until barrel extension is in open position.	3-5/C, D
25	Pull charger handle rearward, depress manual firing trigger and allow charger handle to go forward slowly.	3-5/D
26	Place safety in S (safe) position and close cover.	3-5/B, E
27	Perform after operation preventive-maintenance checks and services (table 4-1, steps 125 and 126).	
<b>3-11</b>		

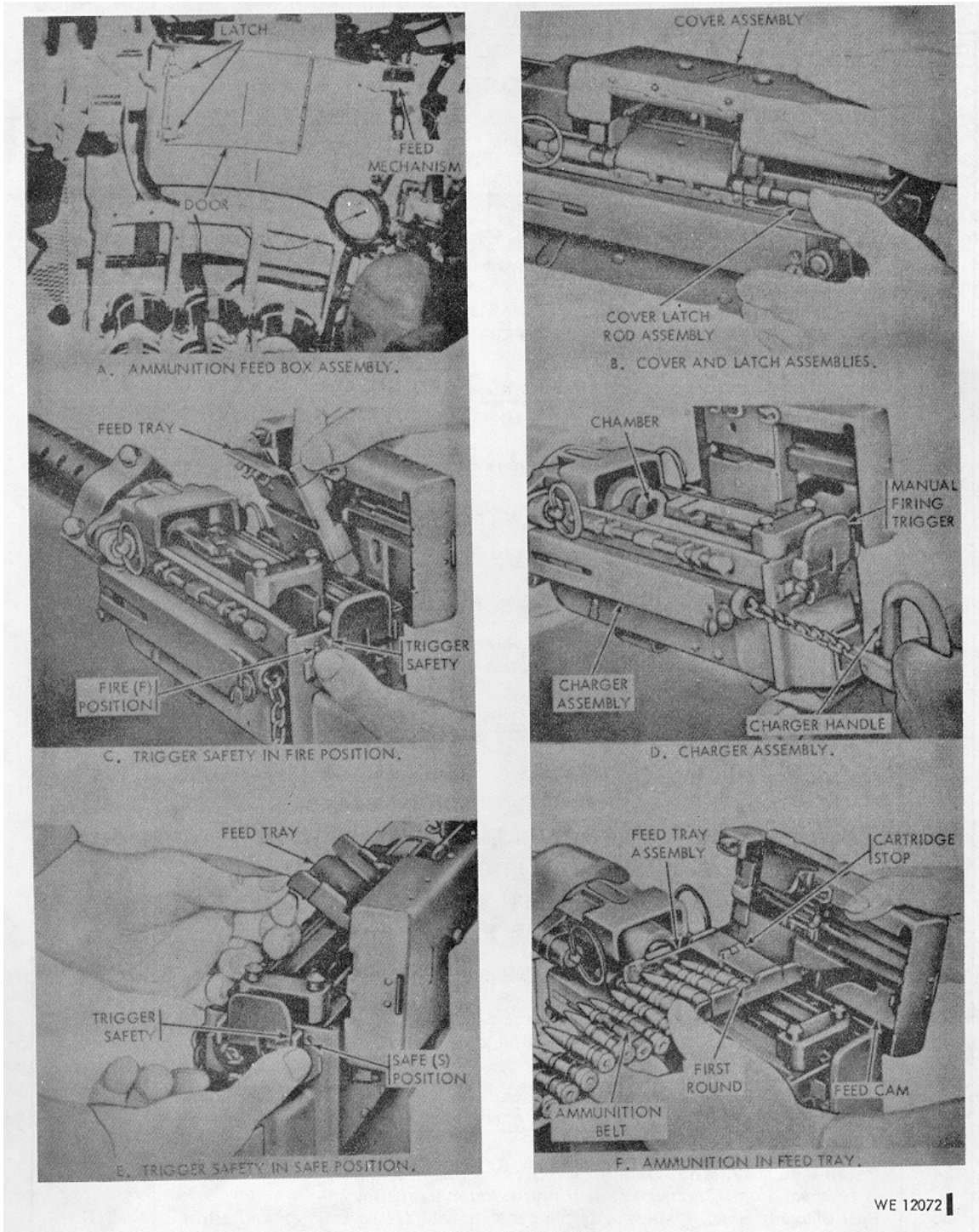

WE 12072

Figure 3-5. 7.62 mm machine gun controls



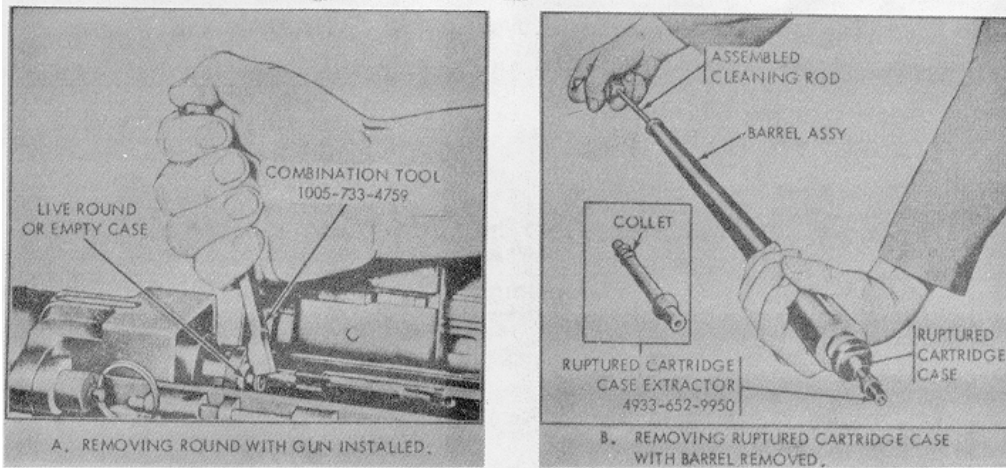

STEP	PROCEDURE
1.	MAKE CERTAIN SAFETY IS IN SAFE "S" POSITION.
2.	POSITION TOOL ON CARTRIDGE CASE HEAD AND PRESS FORWARD TO REMOVE.
:	<b>WARNING</b> <u>INSPECT CHAMBER TO INSURE PROJECTILE WAS NOT SEPARATED FROM CASE DURING REMOVAL.</u>

STEP	PROCEDURE
1.	INSERT EXTRACTOR THROUGH RUPTURED CARTRIDGE INTO BARREL UNTIL COLLET ENGAGES FORWARD END OF CASE.
2.	INSERT ASSEMBLED CLEANING ROD THROUGH MUZZLE END OF BARREL AND DRIVE EXTRACTOR AND RUPTURED CARTRIDGE CASE FROM CHAMBER.

Figure 3-6. Removing live round of, ruptured cartridge case from 7.62 mm machine gun

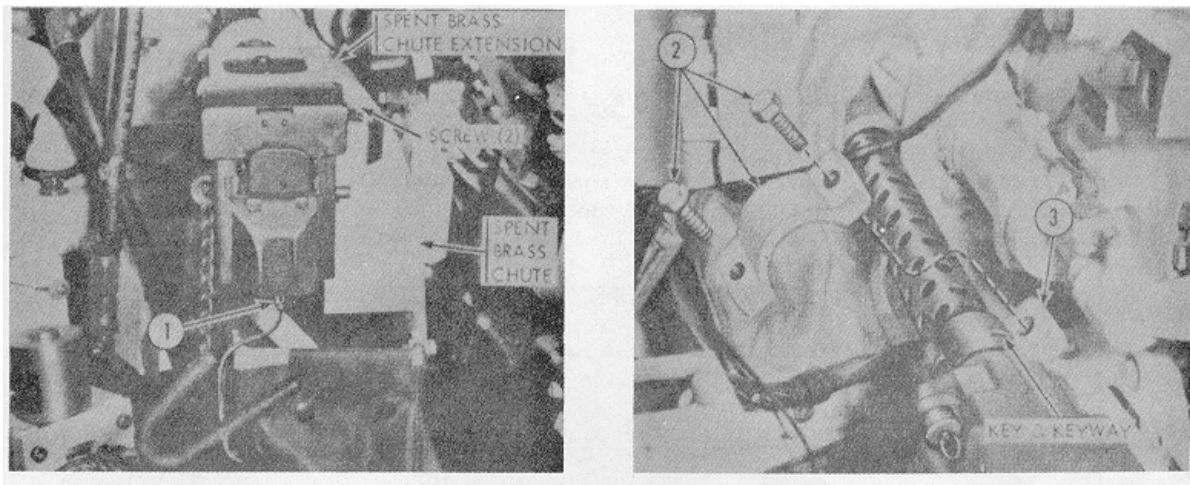

**REMOVAL**

1. DISCONNECT MACHINE GUN ELECTRICAL LEAD.
2. REMOVE 2 SCREWS, MACHINE GUN MOUNT CAP, AND LIFT MACHING GUN OFF MOUNT.

**INSTALLATION**

3. MATCH KEYS ON GUN WITH KEYWAYS IN MOUNT AND REVERSE REMOVAL PROCEDLIRE

**SPENT BRASS EJECTION CHUTE EXTENSION**

INSTALL ON MACHINE GUN COVER AS SHOWN IN ILLUSTRATION, AND TIGHTEN TWO SCREWS. LOOSEN SCREWS TO REMOVE EXTENSION.

WE 120741

Figure 3-7. Removal/installation - 7.62 mm machine gun

Section 3-4. CAL. .50 MACHINE GUN, M2, HB

3-5. Firing Procedure

The following tables and illustrations provide Cal. .50 machine gun, M2, HB firing procedure.

**NOTE.** Before operation the crew should be familiarized with the location and operation of all controls (figs. 3-8 through 3-14).

TABLE 3-6. LOADING, FIRING AND UNLOADING CAL. .50 MACHINE GUN

STEP	PROCEDURE	FIG/ITEM
<b>PREPARATION FOR FIRING</b>		
1	Perform before-operation preventive-maintenance checks and services (table 4-1, steps 24 through 28).	
2	Check headspace and timing. Adjust if required (tables 3-7 and 3-8).	
3	Install flash hider.	3-13
4	Install carrier assembly.	3-10
5	Remove ammunition box cover and place box in ammunition tray. <b>NOTE:</b> <u>The double loop end of ammunition belt must be leading.</u>	3-8/A
<b>LOADING</b>		
6	Open machine gun cover and insert double loop end of ammunition in feedway until first round is held by belt holding pawl.	3-8/B, C
<b>HALF-LOAD GUN</b>		
7	Retract the retracting slide handle, pulling bolt all the way to the rear. Release handle.	3-8/B
8	Position bolt latch release lock to engage bolt latch release when depressed.	3-8/D
9	Push retracting slide handle all the way forward.	3-8/E
10	Press down on bolt latch release, bolt will go forward.	3-8/D
11	To FULLY LOAD gun, repeat steps 6 through 9.	
12	Close gun cover.	3-8/B
<b>SEMI-AUTOMATIC FIRING</b>		
13	Turn bolt latch release lock clockwise to allow bolt latch release to be in raised position. Fire gun by pressing trigger. <b>WARNING:</b> <u>When bolt latch release and trigger are both held down, machine gun will fire automatically.</u>	3-8/D
<b>AUTOMATIC FIRING</b>		
14	Lock bolt latch release down by engaging in bolt latch release lock. Fire gun by pressing trigger. <b>WARNING:</b> <u>For immediate action in case of failure to fire, refer to table 3-3.</u>	3-8/D



TABLE 3-6. LOADING, FIRING AND UNLOADING CAL. .50 MACHINE GUN - CONTINUED

STEP	PROCEDURE	FIG/ITEM
	<p><b>REMOVING RUPTURED CARTRIDGE CASE REMOVAL/INSTALLATION OF BARREL</b></p> <p><b>WARNING:</b> Use asbestos gloves if barrel is hot.</p> <p>(1) Remove barrel from gun.                      (2) Remove carrier assembly and install on spare barrel.                      (3) Remove flash hider and install on spare barrel.                      (4) Install spare barrel.</p> <p><b>NOTE:</b> Carrier assembly must be in 5 or 7 o'clock position on barrel to prevent damage to antenna when cupola is rotated.</p>	<p>3-9</p> <p>5-14/1 3-10 3-13 5-14/1</p>
	<p><b>REMOVAL/INSTALLATION OF MACHINE GUN AFTER FIRING</b></p>	<p>3-14</p>
15	Raise cover and remove ammunition belt.	3-8/B
16	Close cover.	3-8/B
17	Retract bolt and lock in rearward position.	3-8/D, E
18	Raise cover and inspect chamber.	3-8/B
19	Hold handle, release bolt, and allow bolt to move slowly forward.	3-8/D, E
20	Perform after-operation preventive-maintenance checks and services (table 4-1, step 105).	

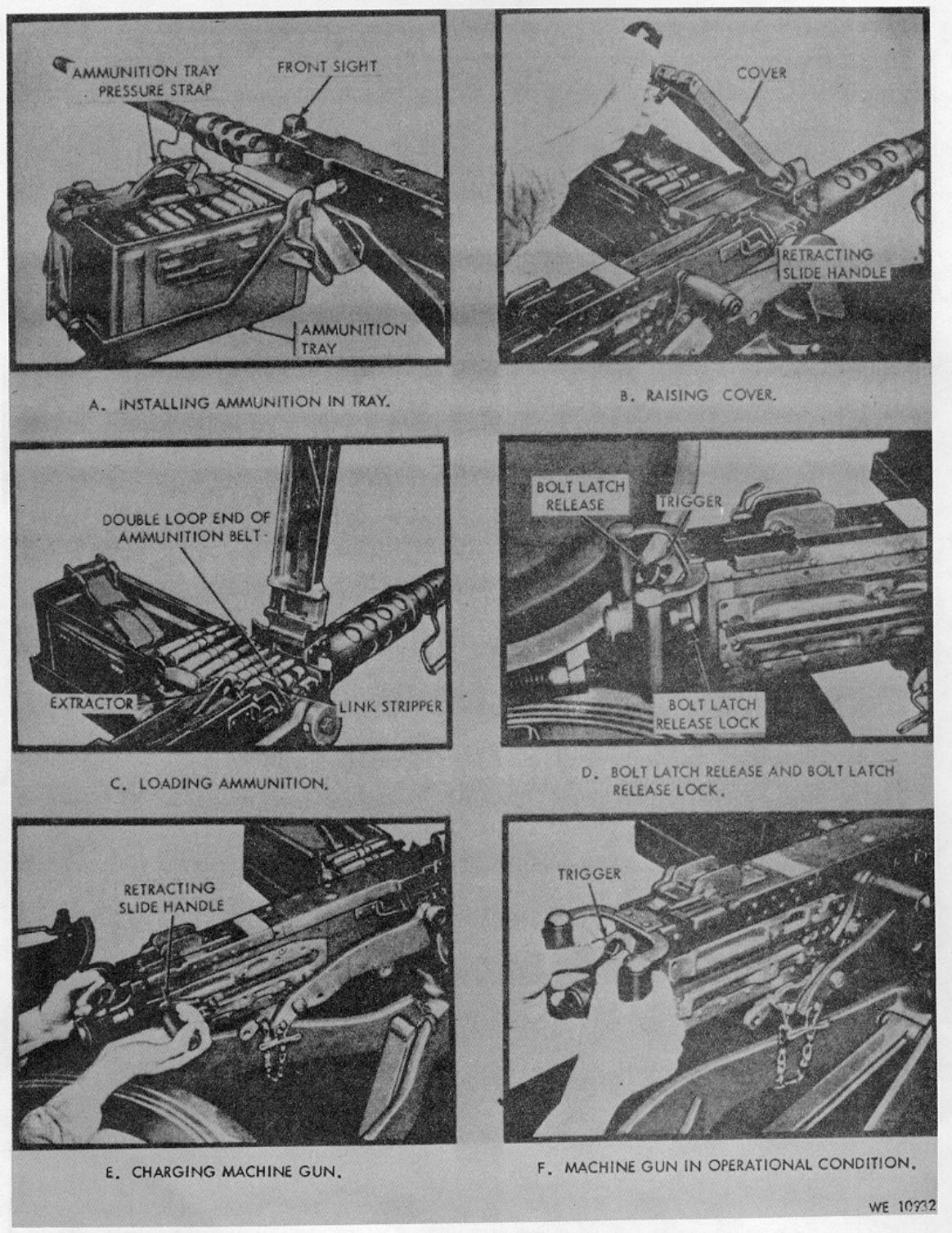

Figure 3-8. Cal..50 machine gun, M2, HB, controls

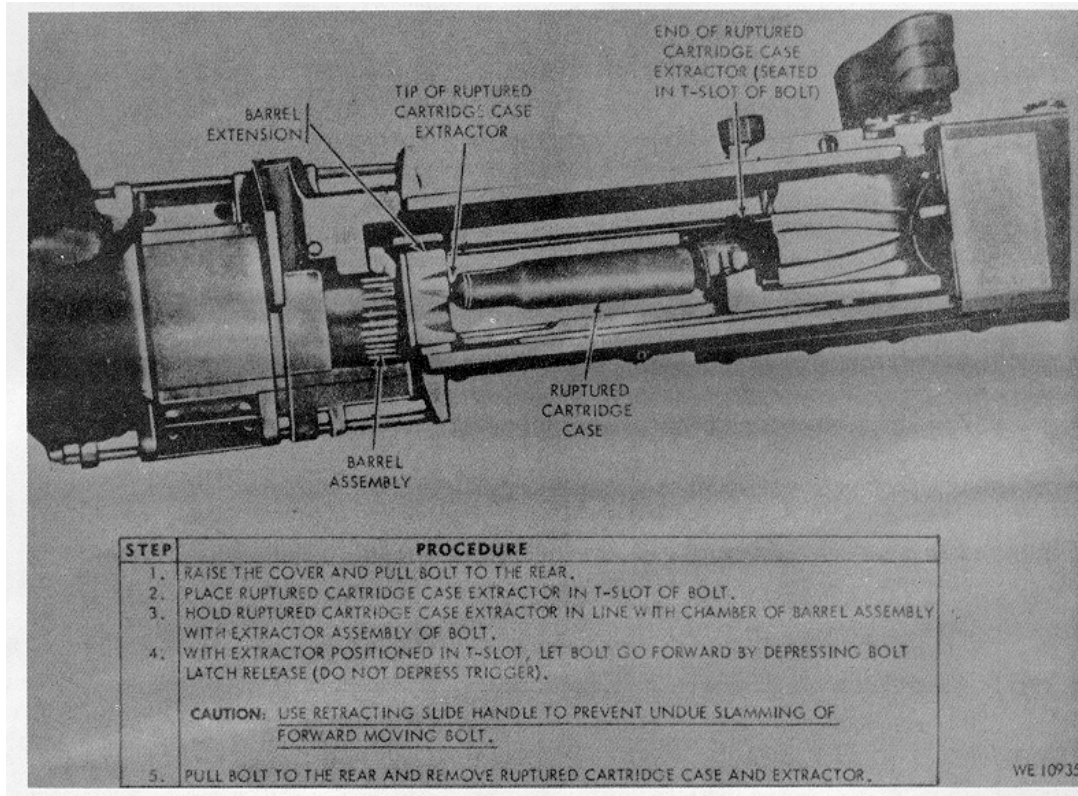

Figure 3-9. Remove ruptured cartridge case from chamber of cal. .50 machine gun

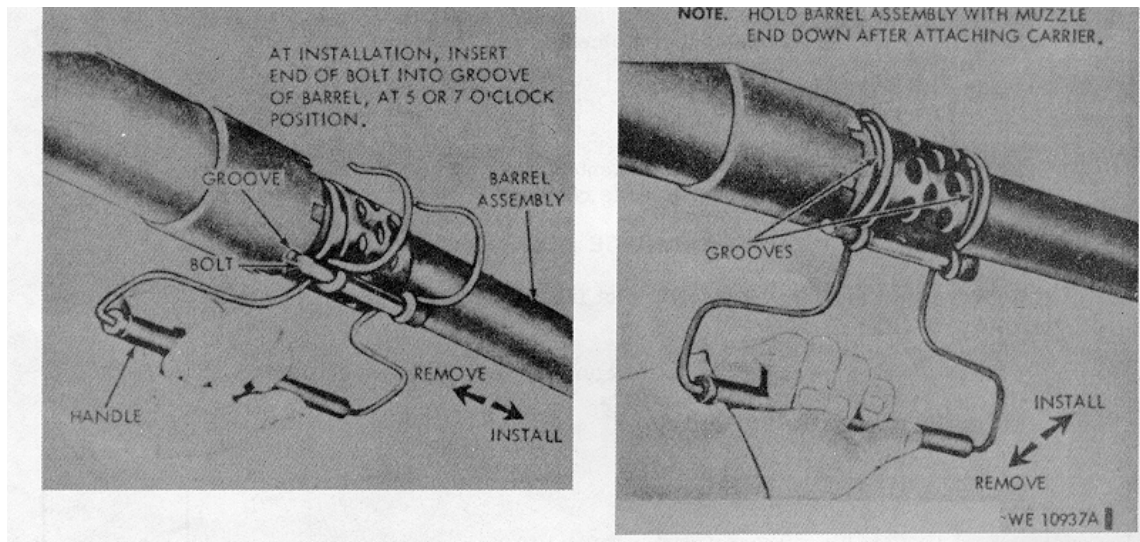

Figure 3-10. (Superseded) Removal/Installation - cal. .50 machine gun carrier assembly/

TABLE 3-7. CHECKING AND ADJUSTING HEADSPACE - CAL. .50 MACHINE GUN

STEP	PROCEDURE	FIG/ITEM
	<p><b>NOTE:</b> <u>Headspace must be checked and/or set prior to firing, after assembling gun and when barrel or any group in the receiver is replaced.</u></p> <p><b>CAUTION:</b> <u>Improper headspace can cause malfunctioning of the gun and frequent damage to parts and/or injury to personnel.</u></p>	
1	Raise cover.	3-8/B
2	Retract bolt (approximately 3/8 inch) using retracting slide handle until locking lug on barrel locking spring is centered in hole of right side plate of receiver.	5-14
3	Hold bolt in above position and screw barrel fully into barrel extension. <b>NOTE:</b> <u>Should handle be released, the recoiling parts will remain out of battery position (a separation will exist between barrel extension and trunnion block).</u>	5-14
4	With handle retracted, unscrew barrel two notches (clicks). Release handle.	5-14
5	Cock machine gun. <b>NOTE:</b> <u>With machine gun cocked, firing pin is withdrawn into face of bolt allowing headspace gage to be inserted into T-slot on bolt.</u> <b>CAUTION:</b> <u>Do not fire gun when headspace gage is in T-slot.</u>	3-8/B 3-11
6	Hold handle, release bolt and allow bolt to return to battery position slowly to prevent bolt slamming.	3-8/D, E
7	Retract recoiling parts approximately 1/16 inch to insure that locking surfaces of breech lock and bolt are in proper contact.	3-11
8	Raise extractor.	3-11
9	Insert GO end of headspace gage into center of T-slot between face of bolt and barrel. <b>CAUTION:</b> <u>Do not force gage.</u>	3-11/A
10	If GO end of gage enters T-slot, to center ring of gage, and the NO GO end will not enter, headspace is correct.	3-11
	<b>HEADSPACE TOO TIGHT</b>	
	If GO end of gage will not enter T-slot freely, perform following procedures:	
11	Retract bolt, step 2 above.	
12	Unscrew barrel one notch (click). Return parts to battery position.	5-14
13	Retract recoiling parts, step 7 above.	
14	Check headspace, step 10 above.	

TABLE 3-7. CHECKING AND ADJUSTING HEADSPACE-CAL. .50 MACHINE GUN - CONTINUED

STEP	PROCEDURE	FIG/ITEM
<p>15 16 17 18</p>	<p style="text-align: center;"><b>HEADSPACE TOO LOOSE</b></p> <p>If NO GO end of gage enters T-slot, perform following procedures:</p> <p>Retract bolt, step 2 above.</p> <p>Screw barrel into barrel extension one notch (click). Return parts to battery position.</p> <p>Retract recoiling parts, step 7 above.</p> <p>Check headspace, step 10 above.</p> <p><b>NOTE.</b> <u>If proper headspace adjustment cannot be obtained, notify organizational maintenance personnel.</u></p>	<p>5-14</p>

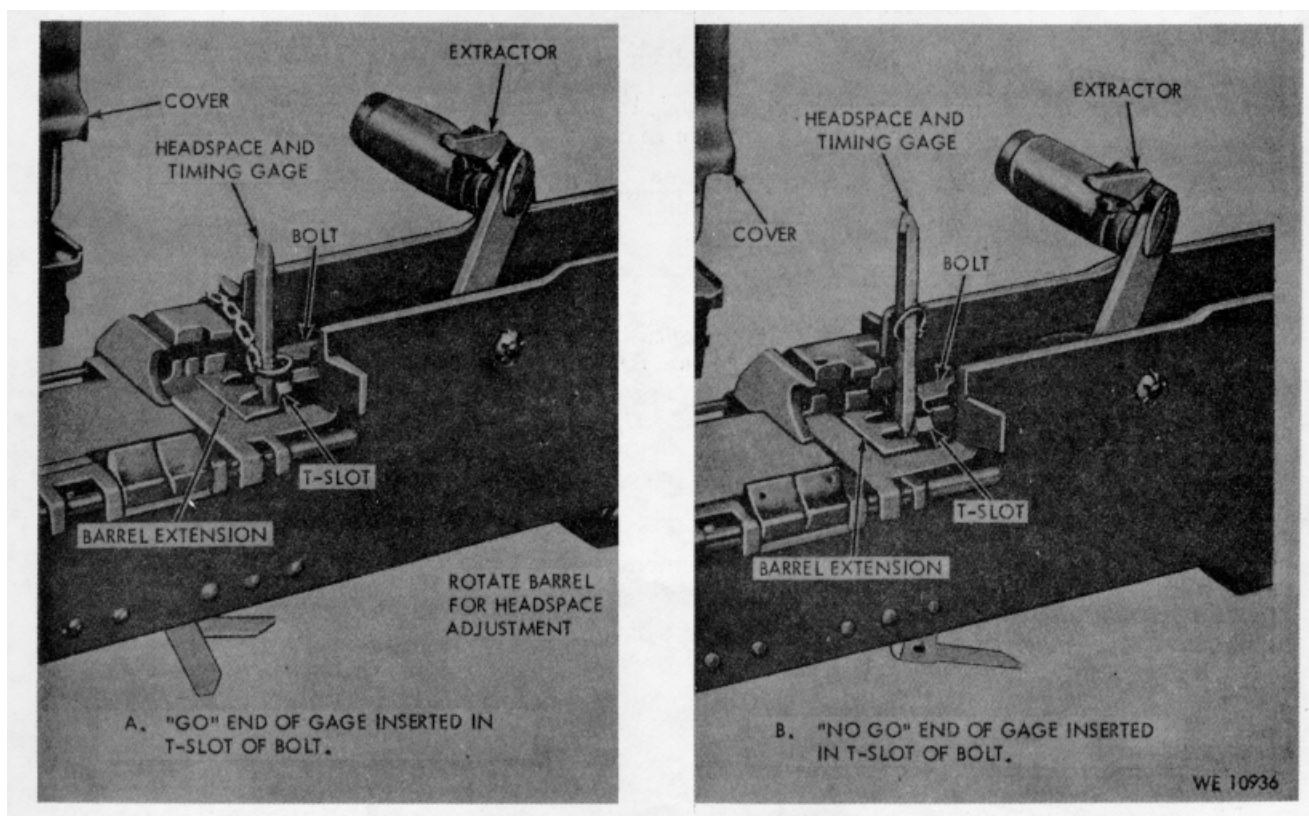

Figure 3-11. Checking and adjusting headspace on cal. .50 machine gun, M2, HB

TABLE 3-8. CHECKING AND ADJUSTING TIMING - CAL. .50 MACHINE GUN, M2, HB

STEP	PROCEDURE	FIG/ITEM
1	Insure headspace is correct (table 3-7).	
2	Cock machine gun. (Retract bolt assembly to rear position and slowly release to forward position. )	3-8/E
3	Raise extractor	3-12/A
4	Retract bolt sufficiently to insert NO FIRE (0. 116-inch) gage between trunnion block and barrel extension group. Release retracting slide handle.	3-12/A
5	Depress the trigger. The firing pin SHOULD NOT RELEASE. In the event it does release repeat steps 2 and 3. <b>WARNING</b> <u>Do not attempt to remove back plate unless the bolt is in forward position. Do not attempt to cock machine gun without the back plate assembled to machine gun.</u>	3-8/F
6	Remove back plate	5-14/4
7	Screw the timing adjustment nut all the way down (counterclockwise)	3-12/B
8	Place the FIRE (0. 020-inch) gage between trunnion block and barrel extension group. Release retracting slide handle.	3-12/D
9	Attempt to release firing pin by lifting up on rear end of trigger lever	13-12/C
10	Screw up (clockwise) on timing adjustment nut one click at a time and attempt to release firing pin after each click until the firing pin does release. When the firing pin does release move the adjusting nut two more clicks clockwise (up).	13-12/C
11	Replace back plate assembly	5-14/19
12	Repeat steps 2 through 5. The firing pin SHOULD NOT RELEASE.	
13	Repeat steps 2 and 3.	
14	Place FIRE gage between trunnion block and barrel extension and attempt to release firing pin by pressing the trigger. The firing pin SHOULD RELEASE.	3-12/D
	<b>NOTE</b> <u>If proper timing adjustment cannot be obtained, notify organizational maintenance personnel.</u>	



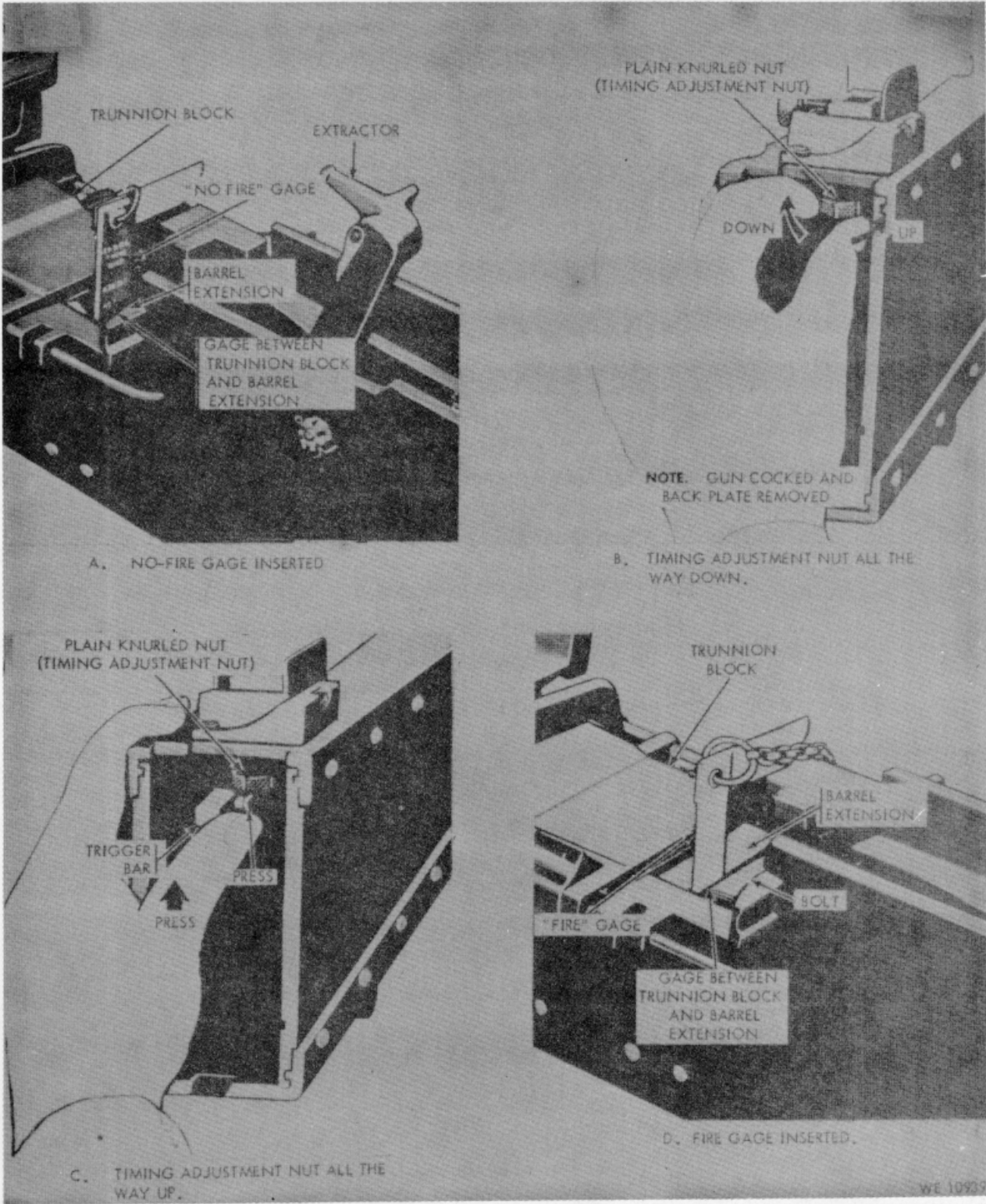

Figure 3-12. Checking and adjusting timing on cal. .50 machine gun M2, HB

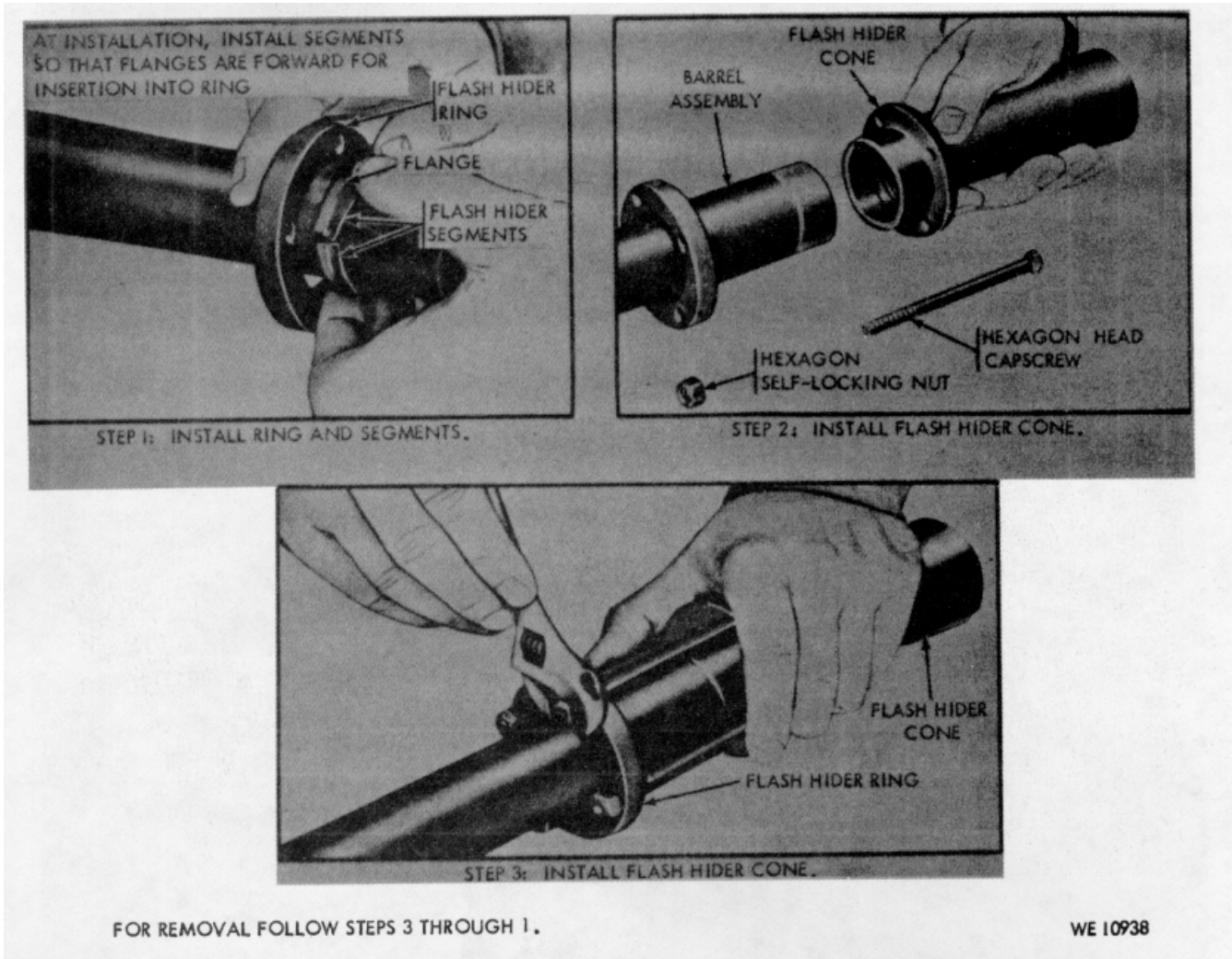
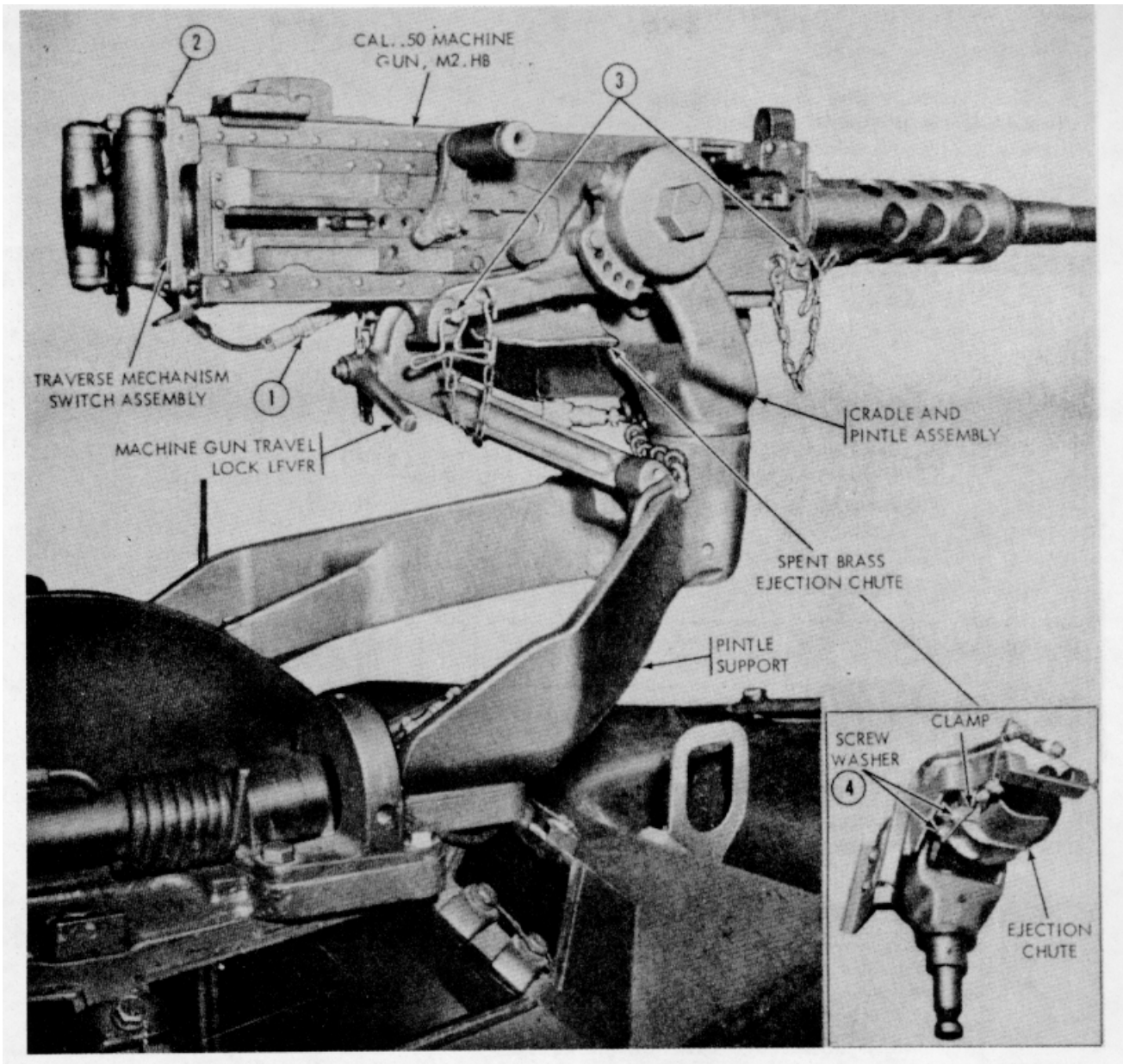

Figure 3-13. Installation/removal - cal. .50 machine gun flash hider





**REMOVAL**

1. DISCONNECT CUPOLA TRAVERSE MECHANISM SWITCH ASSEMBLY QUICK DISCONNECT.
2. REMOVE 4 SCREWS AND SWITCH ASSEMBLY.
3. PULL OUT 2 LOCKING PINS AND REMOVE MACHINE GUN .
4. REMOVE 2 SCREWS AND WASHERS TO REMOVE EJECTION CHUTE AND CLAMP.

**INSTALLATION**

REVERSE REMOVAL PROCEDURE. REFER TO FIGURE 2-4 FOR INSTALLATION OF PINTLE SUPPORT, CRADLE AND PINTLE ASSEMBLY.

WE 12075

*Figure 3-14. Removal/Installation - cal. .50 machine gun and spent brass ejection chute.*

**Section 3-5. (SUPERSEDED) SMOKE DEVICE SYSTEM  
WITH XM176 GRENADE PROJECTOR**

**3-6. Firing Procedure**

The following tables and illustrations provide XM176projector firing system circuit continuity check procedure, immediate action in case of failure to fire, and firing procedure.

**NOTE.** Before operation the crew should be familiarized with the location and operation of all controls (figs. 3-15 through 3-17).

*TABLE 3-9. CHECKING XM176 GRENADE PROJECTOR ELECTRICAL SYSTEM CONTINUITY*

STEP	PROCEDURE	FIG/ITEM
1	<p><b>WARNING:</b> <u>Make certain that projector mounts DO NOT contain grenade projector assemblies.</u></p> <p>Remove control box MASTER switch safety wire and FIRE switch safety safety pin.</p>	3-15/A
2	<p>With vehicle master switch turned on, turn on grenade projector control box MASTER switch. MASTER switch indicator lamp will illuminate. FIRE switch ready lamp will illuminate after short warm-up.</p> <p><b>NOTE.</b> <u>Turn rims of MASTER and FIRE switch indicator lights counter-clockwise for "bright" illumination. Adjust intensity as required after system check-out.</u></p>	3-15/A
3	<p>Through vehicle serial no. 699 remove protective caps from solenoids</p>	3-15/B
3a	<p>On vehicles after serial no. 699, open inspection cover and lift solenoid guard to expose solenoid plunger.</p>	
4	<p>Select LEFT SALVO, RIGHT SALVO, SALVO, and individual positions with control box selector knob and actuate FIRE switch at each position. Visually or physically inspect solenoid action in each position. If not operating properly, notify organizational maintenance personnel.</p> <p><b>NOTE.</b> <u>Approximately four (4) seconds is required between each firing operation to recharge the system power supply.</u></p>	3-15/A, B
5	<p>After checking electrical continuity and solenoid actuation, turn control box MASTER switch to OFF position and install safety wire. Insert safety pin through FIRE switch guard.</p>	3-15/A

**3-7. Hangfire and Misfire**

**a. Misfire.** A misfire is the failure of a grenade projector to fire due to a faulty propellant charge or firing circuit. A misfire is not dangerous but cannot be immediately distinguished from a hangfire. Refer to table 3-10.

**b. Hangfire.** A temporary failure or delay in the action of percussion primer, or propellant charge after FIRE switch has been actuated. Momentarily this delay cannot be distinguished from a misfire or complete failure.

**3-8. Non-Ignited Grenades (Duds)**

The number and precise location of all grenade duds which have failed to function will be recorded and EOD personnel notified of their locations.

**3.9. Storage, Shipment, and Handling**

Refer to TM 3-250.

**3-10. Shipping Container and Stencil Marking**

Refer to figure 3-16.

TABLE 3-10. IMMEDIATE ACTION IN CASE OF FAILURE TO FIRE

STEP	PROCEDURE	FIG/ITEM
1	When misfire or hangfire occurs, wait ten (10) seconds and repeat attempt to fire two additional times.	3-15/A
	<b>NOTE.</b> <u>Approximately four (4) seconds is required between each firing operation to recharge the system power supply.</u>	
2	Should projector(s) fail to fire after three attempts, replace safety pin in FIRE switch guard and turn grenade projector MASTER switch to OFF position and lock wire.	
3	Remain buttoned up in vehicle for 15 minutes (minimum) and advise ground personnel to remain 100 yards to rear of direction of fire.	
4	Release rubber retaining strap and remove projector(s) from mount.	
5	Notify EOD Personnel.	

TABLE 3-11. LOADING, FIRING, AND UNLOADING XM176 GRENADE PROJECTOR

STEP	PROCEDURE	FIG/ITEM
	<b>INSPECTION</b>	
1	Check grenade projector electrical system continuity, table 3-9.	3-16/A
2	Remove grenade projectors from shipping containers <b>WARNING:</b> <ol style="list-style-type: none"> <li>1. <u>Exert caution when handling and loading XM176 grenade projectors.</u></li> <li>2. <u>Under no circumstances attempt to disassemble the XM176 grenade projectors.</u></li> <li>3. <u>Projectors having external cracks, dents or other deformities must not be used. Notify Explosive Ordnance Disposal Personnel (EOD).</u></li> </ol>	
	<b>LOADING GRENADE PROJECTORS INTO MOUNT THROUGH VEHICLE S/N 699</b>	
	<b>CAUTION:</b> <u>Make sure FIRE switch safety pin is installed and box MASTER switch is safety wired.</u>	3-15/A
3	Place projector in mount and engage groove in end of projector with retaining springs in mount. Solenoid plunger must be in contact with face of propellant cartridge when projector is properly positioned.	3-15/C
4	Secure projector in mount with rubber retaining strap. Make sure that crossbar on retainer strap hook is properly engaged in mount.	3-15/C

TABLE 3-11. LOADING, FIRING, AND UNLOADING XM176 GRENADE PROJECTOR-Continued

STEP	PROCEDURE	FIG/ITEM
<b>LOADING GRENADE PROJECTORS INTO MOUNTS AFTER VEHICLE S/N 699</b>		
	<b>CAUTION:</b> <u>Open inspection covers and check tubes for foreign matter before loading. Close inspection covers.</u>	
3a	Rotate locking lever ring at top of tube to release locking levers (figure 3-15. 1) and place grenade projector in tube.	
4a	Rotate ring to locked position.	
<b>FIRING GRENADE PROJECTORS</b>		
5	Secure all hatches before firing projectors	2-6, 2-20
6	Keep ground personnel at least 100 yards to rear of direction of fire.	
7	Using selector knob, select individual grenade projector, LEFT SALVO, SALVO, OR RIGHT SALVO firing.	3-15/A
8	Remove safety wire and turn on grenade projector control box MASTER switch. Green lamp will illuminate.	3-15/A
9	Remove FIRE switch safety pin and double check area for unauthorized personnel.	3-15/A
10	When red "ready" lamp illuminates, press FIRE switch and fire projector(s).	3-15/A
	<b>NOTE.</b> <u>Approximately four (4) seconds is required between each firing operation to recharge the system power supply.</u>	
	<b>WARNING:</b> <u>An installed projector is a loaded weapon and must be treated as such.</u>	3-15/C
<b>MISFIRE AND/OR HANGFIRE</b>		
	<b>WARNING:</b> <u>For immediate action in case of a misfire or hangfire, refer to table 3-10.</u>	
<b>UNLOADING UNFIRED GRENADE PROJECTORS</b>		
	<b>WARNING:</b> <u>When mission is interrupted or completed, all unfired projectors shall be removed from the mounts. Follow steps listed below in exact order to properly disarm and remove projectors.</u>	
11	Install safety pin in FIRE switch guard on control box	3-15/A
12	Turn grenade projector MASTER switch to OFF position and safety wire	3-15/A

TABLE 3-11. LOADING, FIRING, AND UNLOADING XMI76 GRENADE PROJECTOR - CONTINUED

STEP	PROCEDURE	FIG/ITEM
13	Vehicle through serial no. 699: Release retaining straps. Vehicle serial no. 700 or later: Open locking levers.	
14	Remove unfired launchers from tube assemblies and store as live ammunition.	
15	Vehicle through serial no. 699: Install protective caps on solenoids and stow retaining straps.	
15a	Vehicles after serial no. 699: Leave spent launchers in tube assemblies until ready to reload.	

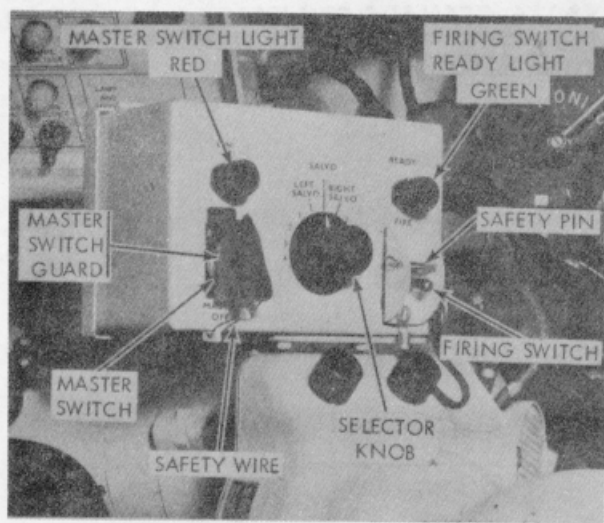

A. GRENADE LAUNCHER CONTROL BOX

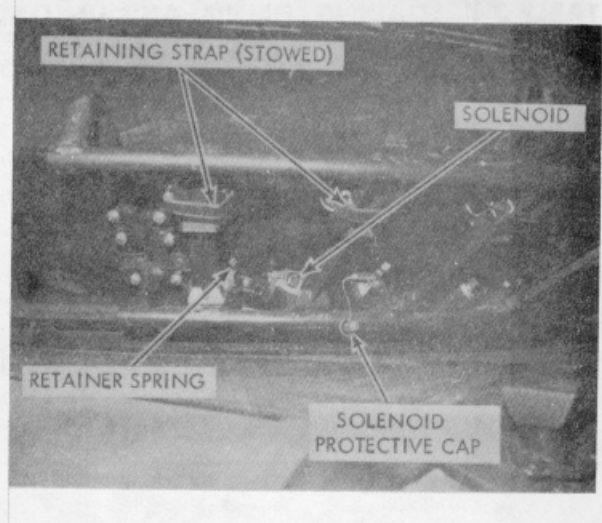

8. GRENADE LAUNCHER MOUNT.  
(EARLY VEHICLES ONLY)

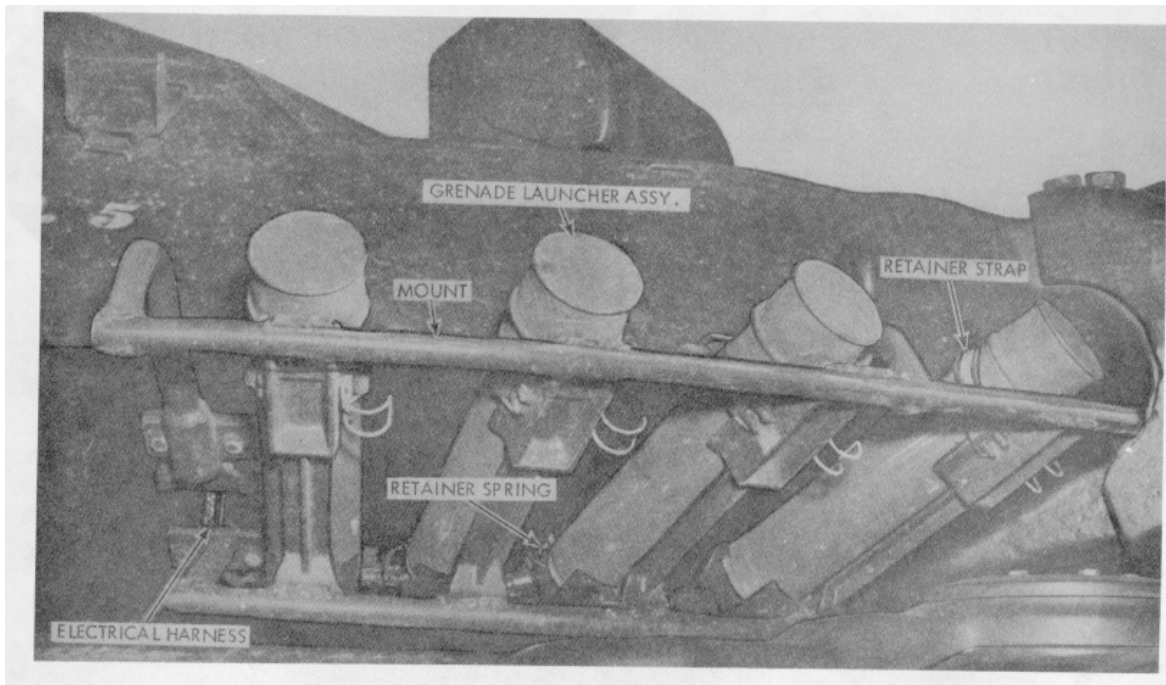

C. GRENADE LAUNCHER ASSEMBLIES INSTALLED IN MOUNT (RIGHT SIDE SHOWN,  
LEFT SIDE SIMILAR. (EARLY VEHICLES ONLY)

WE 66684

Figure 3-15. Grenade launcher mounts and control box  
3-28

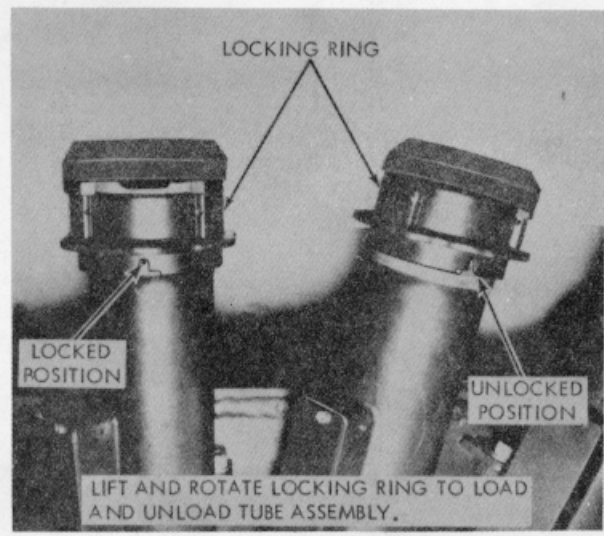
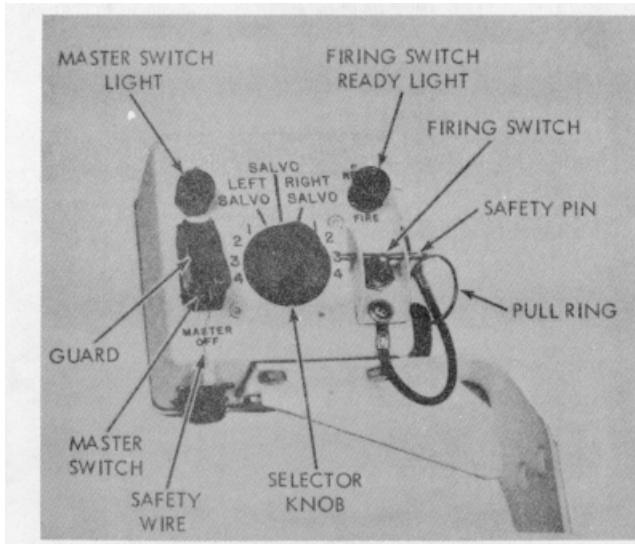

GRENADE LAUNCHER CONTROL BOX

TUBE ASSEMBLY LOCKING LEVER RING

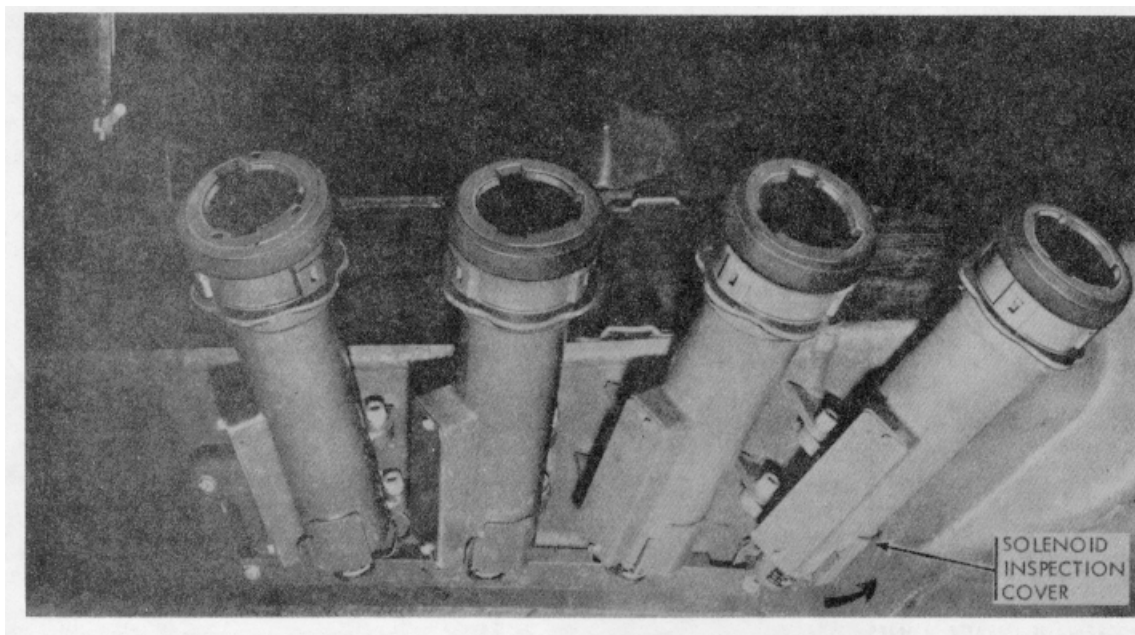

GRENADE LAUNCHER TUBE ASSEMBLIES ON TURRET (RIGHT SIDE SHOWN, LEFT SIDE SIMILAR).

Figure 3-15.1. Grenade launcher tube assemblies and control box.

WE 70042

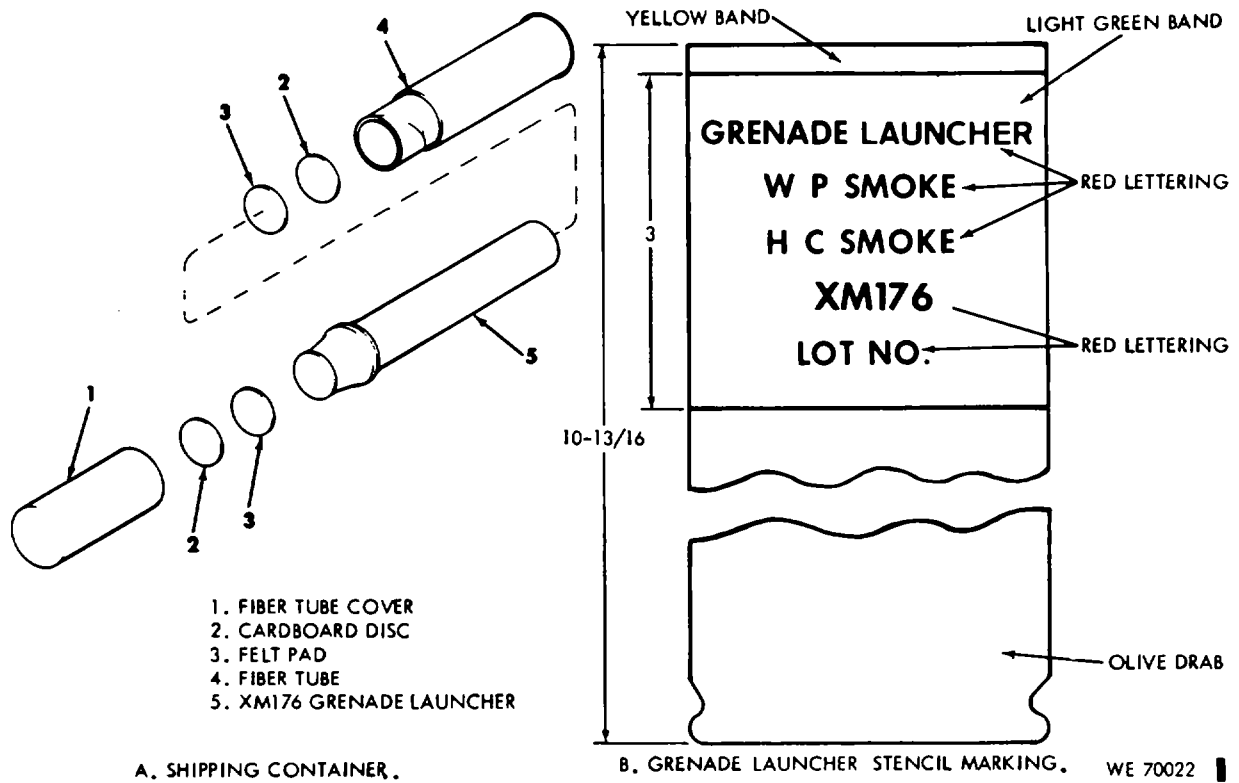

A. SHIPPING CONTAINER.

B. GRENADE LAUNCHER STENCIL MARKING. WE 70022

Figure 3-16. XM176 grenade launcher shipping container and stencil marketing.

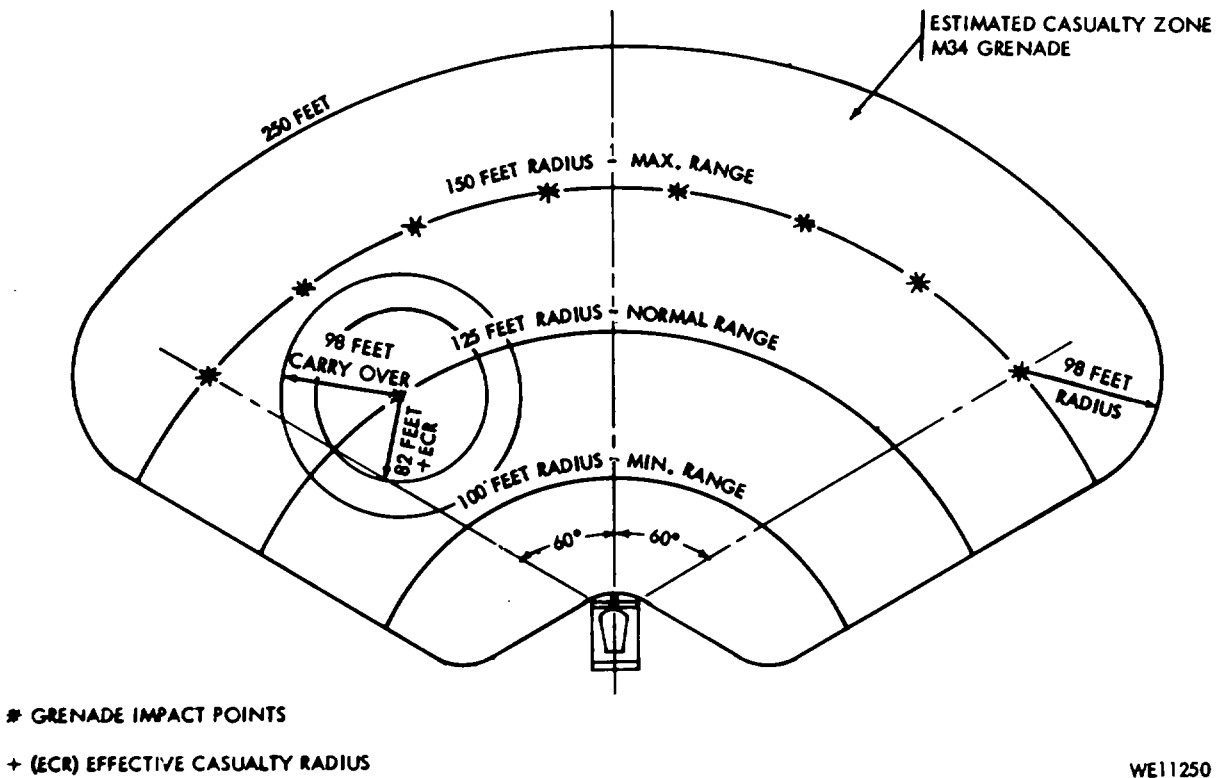

Figure 3-17. XM176 grenade launcher M34 WP estimated casualty zone (flat terrain).



## CHAPTER 4 CREW PREVENTIVE-MAINTENANCE SERVICES

### Section 4-1. PREVENTIVE-MAINTENANCE SERVICES

#### 4-1. Specific Procedures (Normal Conditions)

a. General. This section contains specific preventive-maintenance checks and services of materiel to be performed by the crew. Checks and services will be performed in numerical sequence as indicated in table 4-1. Refer to TM 38-750 for instructions on use of forms pertaining to preventive-maintenance services.

b. Responsibility. Perform all before, during, and after-operation preventive-maintenance checks and services each day that vehicle is operated, in order to detect first signs of failures and to take corrective action before extensive repairs are required. While operating the vehicle, the crew should be alert for any unusual noises, odors, abnormal instrument readings, steering irregularities or any other vehicle malfunction indication.

The crew should be familiar with quarterly organizational preventive-maintenance service requirements, and assist in the accomplishment of these services.

#### 4-2. Specific Procedures (Unusual Conditions)

a. Vehicles exposed to extreme-cold or hot weather will require more frequent servicing. Materiel subjected to salt-water immersion should be evacuated to organizational maintenance as soon as possible after exposure.

b. The letter "C" following the numerical sequence number in the interval column indicates services to be performed when operating under cold weather environment.

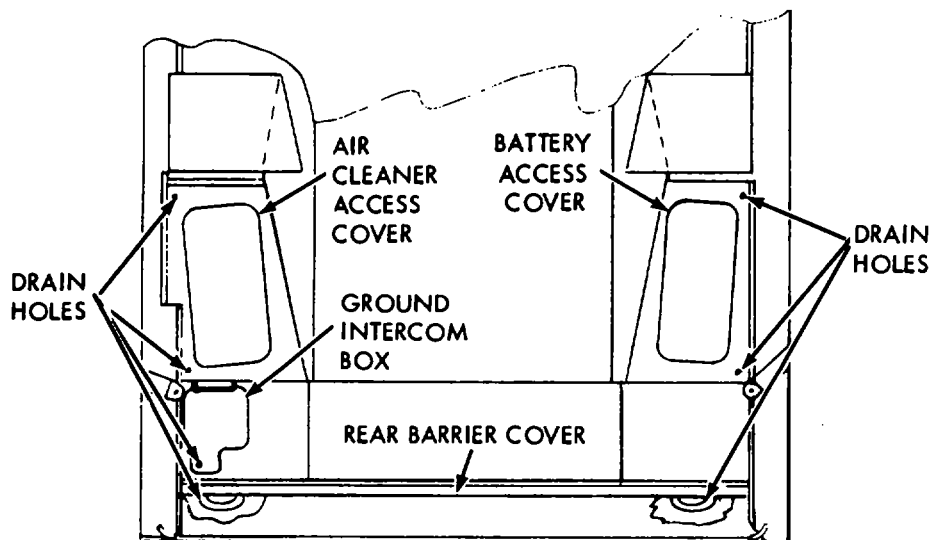

WE 11931

Figure 4-1. Hull drain holes

### Section 4-2. LUBRICATION

#### 4-3. Service Intervals (Normal-Unusual Conditions)

a. Service Intervals (Normal Conditions). LO 9-2350-230-12 (Appendix IV).

b. Service Intervals (Unusual Conditions). Reduce lubrication intervals to compensate for abnormal

operation and extreme conditions, such as high or low temperatures, prolonged periods of high-rate operation, continued operation in sand or dust, or exposure to moisture, any one of which may quickly destroy the protective qualities of the lubricant. Lubrication intervals may be extended during inactive periods.

Table 4-1. PREVENTIVE-MAINTENANCE CHECKS AND SERVICES

INTERVAL AND SEQUENCE			B - BEFORE OPERATION D - DURING OPERATION A - AFTER OPERATION		REFERENCE
B	D	A	ITEM TO BE INSPECTED	PROCEDURE	
		74	Vehicle	Clean interior and exterior, removing dirt, mud, and excess grease. Use water hose on vehicle exterior only, avoid directing stream in areas where it might enter fire control or armament openings, vehicle interior, engine exhaust system or personnel heater outlet.  <b>NOTE.</b> <u>Visually inspect for evidence of lubricant and fuel leaks.</u>	Table 4-2
1		75	Components	Inspect entire suspension system for tampering, excessive wear, damage, or looseness.	Figs. 1-1, 2
	64	76	Wheel Hubs and Shock Absorbers	a. Feel wheel hubs cautiously for noticeable variations of temperature between like components An overheated hub indicates a maladjusted, inadequately lubricated, or damaged bearing. Shock absorbers should feel warmer than the hull. If cold, shock absorbers are not working.	Fig. 5-4
2		77		b. Check grease in road wheel and idler hubs, or check for lubricant leaks	Figs. 9-64 and 9-69
		78	Torsion Bars	Pry up each road wheel to detect broken torsion bars Broken front torsion bars may be detected by the absence of the sharp angle of track as it passes under the road wheel. Check if torsion bar covers are secure.	Fig. 5-4
3		79	Track	Check track tension. Adjust if required  <b>NOTE.</b> 50 miles after initial break-in or whenever track pin nuts have been disturbed, retorque track pin retaining nuts to 120-130 lbs. -ft.	Fig. 5-4
				<b>HULL (EXTERIOR)</b>	
4		80	Driving Lights	Check operation. Inspect for broken or discolored lenses Turn on infrared lights and check operation by placing hand on lens. Heat will be noticeable if light is operating. Replace damaged lamps if authorized.	Figs. 2-8 and 5-6
		81	Towing Shackles	Must be secure	Fig. 2-15
		82	Personnel Heater, Bilge Pump, Exhaust outlets, and Hull Drain Holes	Remove any mud or debris. Clean drain holes with wire or suitable tool	3, 17, Fig. 1-1 and 4, Fig. 1-2 Fig. 4-1
5			Fixed Fire Extinguisher Exterior Control	Check condition of fixed fire extinguisher exterior actuating handle. Safety wire must be intact.	18, Fig. 1-1

Table 4-1. PREVENTIVE-MAINTENANCE CHECKS AND SERVICES

INTERVAL AND SEQUENCE			B - BEFORE OPERATION D - DURING OPERATION A - AFTER OPERATION		REFERENCE
B	D	A	ITEM TO BE INSPECTED	PROCEDURE	
6		83	Exterior Stowage	Check condition and secure stowage of basic-issue items	Figs. 1-1 and 1-2
		84	Access Plugs	Make sure all access plugs are installed and secure on underside of hull.	Fig. 5-7
		85	Batteries	Check battery electrolyte level; electrolyte level should be up to split ring as indicated on battery filler opening. Inspect lugs, terminals and cables for corrosion. Check for loose battery hold-downs and brackets. If electrolyte level is repeatedly low or batteries excessively hot and boiling, notify organizational maintenance personnel.	Fig. 5-0 D, Fig. 5-3
6.1	64.1	86	Air Cleaner	<p>Check air restriction indicator. If indicator is red, clean filter element</p> <p><b>CAUTION:</b> <u>Do not hold element to exhaust for cleaning as diesel oil film will make it unserviceable. Handle element carefully to prevent denting or damage.</u></p> <p><b>NOTE:</b> <u>Under severe dust conditions, engine power loss or excessive black exhaust smoke may indicate need for more frequent cleaning. During operation in severe dust, check air restriction indicator frequently.</u></p> <p style="text-align: center;"><b>ENGINE COMPARTMENT</b></p> <p><b>CAUTION:</b> <u>Before starting engine, make sure of adequate coolant, and adequate oil supply in engine and transmission.</u></p>	<p>Fig. 5-1 Fig. 5-0</p> <p>Fig. 4-6</p>
7			Engine	With engine off, check connections and inspect for lubricant leaks. Start engine, observe if it develops adequate cranking speed and starts without excessive noise. Listen for unusual noises in engine that might indicate improper operation or lack of lubrication.	A, Fig. 5-2
8		87	Surge Tank	Check coolant level. Add if required to fill mark on tank	A, Fig. 5-2
9		88	Engine Oil Level Indicator	Check oil level. Add oil as required (LO 9-2350-230-12),	A, Fig. 5-2
		89	Engine Breather Drain Collector Box	Check for visible signs of overflow or spattering of oil from box. Drain if such signs are found.	B, Fig. 5-3
9.1		89.1	Coolant Pump Drive Belts	Check for proper belt tension	Fig. 5-1.1
		89.2	Coolant Radiator	Check cleanliness of radiator fins and tubes. Clean with low pressure air radiator cleaning system.	Fig. 4-6
		90	Generator/Fan Drive Belts	Check drive belts tensioner. If pin is less than 1/4-inch from bracket, notify organizational maintenance personnel,	A, Fig. 5-2

Table 4-1. PREVENTIVE-MAINTENANCE CHECKS AND SERVICES

INTERVAL AND SEQUENCE			B - BEFORE OPERATION D - DURING OPERATION A - AFTER OPERATION		REFERENCE
B	D	A	ITEM TO BE INSPECTED	PROCEDURE	
10		90.1	Fuel Filters	Drain condensation into suitable container	C, Fig. 5-2
11C			Engine Air Box (Flame) Heater	Check accumulator pressure. If pressure is not maintained notify organizational maintenance.	Fig. 2-14
12		91	Transmission Oil Level Indicator	Check oil level. Add oil as required (LO 9-2350-230-12),	A, Fig. 5-2
<b>DRIVER'S COMPARTMENT</b>					
13		92	Fixed Fire Extinguisher	Visually inspect fire extinguisher for evidence of any defect in cylinder mounting brackets, control mechanism, discharge lines, or damaged seals (safety wire).	B, Fig. 2-18
14C	65C	93C	Personnel Heater	Check for proper operation. Inspect for fuel and exhaust leaks.	Fig. 2-17
		94	Driver's Hatch Cover	Must lock securely in open and closed positions. Check latches and seals for damage or deterioration.	B, Fig. 2-6
		95	Driver's Seat	Examine seat for loose nuts and screws and proper operation.	A, Fig. 2-6
		96	Ammunition Racks	Check for broken latches and hinge pins	Fig. 3-3
15		97	Bilge Pumps	Check operation and service	Fig. 2-13
16	66	98	Switch and Indicator Panels	Check panels for proper mounting and loose connections Observe for normal readings and operation of gages, instruments, warning lights, and indicator lights. Check selector knob setscrews.	Figs. 2-9 and 2-10
17		99	Fuel Gage	Check fuel level	Fig. 2-9
				<b>NOTE.</b> <u>Refill tank immediately after operation to avoid condensation.</u>	
	67		Driving Controls	Inspect and operate steer, shift, accelerator, and brake controls. Note any binding or excessive play in linkage. Check brake for ability to hold on steep grades.	Fig. 2-5
18			M47 and M48 Periscopes	a. Check that all components of the wiper assembly are functioning properly.	Fig. 2-7
19		100		b. Check periscope washer fluid reservoir and refill	Fig. 2-7

Table 4-1. PREVENTIVE-MAINTENANCE CHECKS AND SERVICES

INTERVAL AND SEQUENCE			B - BEFORE OPERATION D - DURING OPERATION A - AFTER OPERATION		REFERENCE
B	D	A	ITEM TO BE INSPECTED	PROCEDURE	
<b>TURRET (EXTERIOR)</b>					
20		101	Exterior Stowage	Check condition and stowage of exterior basic-issue items	Figs. 1-1, 2
21			Gun-Launcher Tube	a. Wipe dry before firing	5, Fig. 1-1
22		102		b. Check for powder fouling, corrosion, and other damage.	
				c. Check equipment log book (Form 2408-4)	App. I
23		103	Bore Evacuator Chamber	Check for dents and improper seals. Assure that bore evacuator is secure to tube.	
		104	Deleted		
23.1		104.1	Grenade launcher mount (thru veh. SN 699)	Check wiring harness and connectors. Check operation of solenoids. Notify organizational maintenance if defects are found.	Table 3-9 Fig. 3-15
23.2		104.2	Grenade launcher tubes (eff. Veh. SN 700)	On vehicles SN 700 and above, check for bent, dented, corroded or damaged tubes. Check operation of solenoids. Notify organizational maintenance if defects are found. Clean tubes and leave a light film of oil on inside of tube. Assure solenoids are left oil-free.	Table 3-9 Fig. 3-15.1
<b>CAL. .50 MACHINE GUN</b>					
<b>WARNING:</b> Clear machine gun before initiating inspection.					
24			Barrel	Assure that bore and chamber are dry and free of obstruction.	
25			Back Plate Assy	Assure positive functioning of latch, latch lock, and safety.	Fig. 5-14
26			Cover Group	Assure positive engagement of latch	B, Fig. 3-8
27			Feed Mechanism	Ascertain free movement of latch and feed mechanisms.	
		105	Retracting Slide Group Assy.	Operate slide to assure freedom of movement	E, Fig. 3-8
28			Headspace and Timing	Check and/or adjust	Tables 3-7, 8
<b>COMMANDER'S CUPOLA</b>					
29		106	Hatch Covers and Seals	Check to insure split hatch covers lock securely in all positions and have a watertight seal.	B, Fig. 2-20
		107	Vision Blocks	Inspect for signs of ineffectual sealing, clouding, objectionable scratches, or pits on surface of glass.	2, Fig. 2-21
29.1		1071	Slip Ring and Brushes	Inspect. Clean as necessary with dry cloth.	

Table 4-1. PREVENTIVE-MAINTENANCE CHECKS AND SERVICES

INTERVAL AND SEQUENCE			B - BEFORE OPERATION D - DURING OPERATION A - AFTER OPERATION		REFERENCE
B	D	A	ITEM TO BE INSPECTED	PROCEDURE	
30		108	Traverse Mechanism	<p>Rotate full 360 degrees manually to determine that ring gear is free and backlash is not excessive. Power traverse cupola 360 degrees in each direction with traverse mechanism switch assembly buttons on machine gun spade grips and rotation switch on cupola control assembly. Cupola should not coast after release of buttons or rotation switch.</p> <p style="text-align: center;"><b>TURRET (INTERIOR)</b></p> <p><b>NOTE</b> Check selector knob setscrews.</p>	Figs. 2-4, 2-21, 2-22 Table 2-8
31		109	Loader's Hatch Cover	Check seal and crash pad for damage or deterioration Hatch cover must lock securely in open and closed positions.	D, Fig. 2-20
32			Turret Seats and Pads	Check for ease of operation and adjustment Inspect cushions and pads for secure mounting and serviceable condition.	A, C, F, Fig. 2-20
33		110	Turret Traverse Lock	Check for effective operation	C, Fig. 2-20
34			Ammo Racks and Protective Screens	Check pin safety clips securing vertical ammo rack and screens to turret ring to be sure they are installed.	Fig. 2-27
35		111	Ammo Racks	Check ammo arms and catches for shell holding tension Determine if shell pads are present and properly installed.	Fig. 3-3 and 3-3.1
		112	Stowage Boxes	Clean miscellaneous boxes of corrosion and debris	C, Fig. 2-20
35.1	67.1	112.1	Floor Access	Clean debris from under turret floor as necessary	Fig. 4-3
36			Fuel Tank(Center)	Drain condensation	A, Fig. 5-3
37		113	Interior Basic-Issue-Items	Check condition and stowage.	
38		114	Turret Ventilating Fan	Check operation	E, Fig. 2-20
39		115	Dome Lights	Check operation. Replace lamps if defective	D, Fig. 2-6
40		116	Turret Traverse Mechanism	With vehicle on level ground, traverse turret full 360 degrees manually and with power. Effort required to manually traverse should be uniform and must not have over 1-1/2 mils of backlash. If manual control shaft binds, coat with PL.	Table 2-7

Table 4-1. PREVENTIVE-MAINTENANCE CHECKS AND SERVICES

INTERVAL AND SEQUENCE			B - BEFORE OPERATION D - DURING OPERATION A - AFTER OPERATION		REFERENCE
B	D	A	ITEM TO BE INSPECTED	PROCEDURE	
41		117	Elevating Mechanism	<p><b>TURRET (INTERIOR) - Continue</b></p> <p>Elevate and depress through entire range manually and electrically. Check operation for smoothness, ease of operation, and for not more than 1-1/2 mile of backlash.</p>	Table 2-7
42			Control Handle Trim Button	Adjust for any elevation or azimuth drift	Figs. 2-19, 21
41.1			Power Control Handle	Clean between heel of palm switch and control handle with the thin bladed tool, as required, to prevent build-up of dirt.	Fig. 2-19
43			M8A3 Air Filter Unit	Check operation of filter unit and listen for unusual noises. Inspect all components for damage, wear, missing components, and tightness. Inspect air flow control cape for tightness. Report deficiencies to organizational maintenance personnel.	Table 2-6
44	118		Radio Equipment	<p>a. Check the completeness and general condition of the equipment.</p> <p>b. Use a clean lint-free cloth to remove dust, dirt, moisture, and grease from the antenna, antenna matching unit, front panel controls of the components and audio accessories. If necessary, wet the cloth with cleaning compound 7930-395-9542. Wipe the parts with a clean dry cloth.</p> <p><b>WARNING:</b> <u>Cleaning compound (Federal Stock No. 7930-395-9542) is flammable and its fumes are toxic. Do not use near a flame; provide adequate ventilation.</u></p> <p>c. Check to see that all controls work smoothly, are tight on the shaft, and do not bind.</p> <p>d. Check for normal operation.</p> <p>e. Inspect cords and cables for cuts, kinks, breaks, fraying, and undue strain.</p> <p>f. Inspect for loose connectors.</p> <p>g. Clean dial windows with a clean, dry cloth.</p> <p>h. Replace lamps if defective.</p> <p><b>152MM GUN-LAUNCHER</b></p> <p><b>WARNING:</b> Clear weapon before starting inspection.</p>	Figs. 7-4, 5
44.1	67.2	118.1	Detent Assembly and Check Valve	<p>Notify Organizational Maintenance to service:</p> <p>a. Check valve after each 100 rounds</p> <p>b. Type I or n detent assembly</p> <p>(1) After each day's firing - not to exceed 40 rounds between cleaning</p> <p>(2) Upon completion of firing when no more firing is anticipated (Detent will be cleaned three consecutive days in conjunction with cannon tube per L09-2350-230-12. )</p> <p>(3) Every 90 days when not firing</p> <p><b>4-7</b></p>	For detent assembly identification refer to para 3-3, 4

Table 4-1. PREVENTIVE-MAINTENANCE CHECKS AND SERVICES

INTERVAL AND SEQUENCE			B - BEFORE OPERATION D - DURING OPERATION A - AFTER OPERATION		REFERENCE
B	D	A	ITEM TO BE INSPECTED	PROCEDURE	
				<b>152MM GUN-LAUNCHER</b>	
44.1	67.2	118.1	Detent Assembly and Check Valve	<b>WARNING:</b> Clear weapon before starting inspection. Notify Organizational Maintenance to service detent each 40 rounds and check valve each 100 rounds.	
45		119	Electrical Lead	Check for positive connection	E, Fig. 3-1
		119.1	Gun-Launcher Tube	After firing, gun-launcher tube must be cleaned daily (M81 tubes must also have bore evacuator valves and chamber cleaned daily).	Table 5-8. 1
46	68	120	Breech Mechanism Assembly	a. Open and close breech both manually and electrically to assure smoothness of operation and that no binding exists. Check the fully closed position for alignment of scribe marks on breech chamber with index mark on coupling. b. On the opening cycle, check operation of missile cap ejector when ejector trigger lever is in the eject (down) position. Just prior to ejection, check missile case detent in gun tube chamber to insure it is completely withdrawn. At full open breech position, the detent should protrude into chamber.	E, Fig. 3-1  D, E, Fig. 3-1
46.1	68.1	120	CO2 Bore Scavenging System	After each 10 rounds, check CO2 bottle weight	Fig. 3-2.1 and 3-2. 2
47		121	Obturator Seal	Check to insure seal is not damaged and is in proper position in gun tube Clean as specified in Table 5-8. 1	Fig. 5-101 Table 5-8.1
47.1	68.2		Firing Probe	<b>CAUTION:</b> <u>When firing conventional ammo clean firing probe every 5-10 rounds.</u> Clean probe with rough cloth or steel wool (FSN 5350-242-4404). Check firing probe continuity	Fig. 4-4
47.2			CBS Pressure Gage and System Operation	<b>NOTE:</b> <u>Every 200 conventional rounds interval, notify organizational maintenance to remove, clean, and inspect probe and seal seat on breechblock face.</u> <b>CLOSED BREECH SCAVENGING SYSTEM</b> a. Check pressure gage if pressure is below 2700 PSI start vehicle engine and operate compressor to charge system to 3100 + 100 PSI. <b>CAUTION:</b> <u>Avoid damage to air cylinders, which are under very high pressure.</u>	Fig. 3-9 3
		121.1	Compressor	b. Momentarily actuate manual discharge lever to check operation of system. a. Inspect compressed air lines, oil lines and mounting hardware for loose connections or leakage. Notify organizational maintenance to correct defects. b. Clean finned tubes and fan screen as required. c. Inspect cooling tubes for distortion, cracks, dents and loose connections. Inspect fan for dents, bent blades, looseness or other defects. Notify organizational maintenance to correct defects.	Fig. 3-2.4
<b>4-8</b>					



Table 4-1. PREVENTIVE-MAINTENANCE CHECKS AND SERVICES

INTERVAL AND SEQUENCE			B - BEFORE OPERATION D - DURING OPERATION A - AFTER OPERATION	REFERENCE	
B	D	A	ITEM TO BE INSPECTED	PROCEDURE	
	68.3		Compressor	<p><b>CLOSED BREECH SCAVENGING SYSTEM - Continued</b></p> <p>d. Remove any object obstructing moving parts.</p> <p>e. After each day of operation check oil level Clean area around filler hole. Add oil to full mark. Under extreme operating conditions, such as excessively high or low temperatures, prolonged operating periods, operation in sand or dust, or immersion in water, notify organizational maintenance for additional service.</p> <p>Monitor compressor for: unusual noises, vibration, smoking, or overheating. If cause of abnormal operation cannot be located and corrected, shut down compressor and notify organizational maintenance.</p>	Fig. 3-2.4
		121.2	Compressor	Visually Inspect compressor for obvious signs of damage, oil leaks, looseness or wear. Notify organizational maintenance to correct defects.	
47.3		121.3	CBS Hoses	Check CBS hoses for air blisters under outer cover Bleed air from blisters larger than dime-size.	Fig. 4-5
				<b>MOUNT</b>	
48	69	122	Mount	Elevate and depress weapon throughout entire range, observing performance.	
49	70	123	Recoil Mechanism	a. Check for leakage Notify organizational maintenance if leak is evident.	Fig. 3-2
	71			b. Check for smooth operation and complete return to battery without undue shock.	
	72	124	Counter-recoil Buffer	a. Check for leakage	Fig. 5-9
50				b. Check oil level (Mounts without buffer bleed line <u>only</u> ).	Fig. 5-9
51			Mount Reservoir	Check fittings for loose connections Check hydraulic fluid level.	Fig. 3-2
52	73		Safe-to-Fire Mechanism	Check to insure that indicator rod is within operating range	Fig. 3-2
				<b>7.62MM MACHINE GUN,</b>	
				<b>WARNING: Clear weapon before initiating inspection.</b>	
53			Feed components, safety and manual trigger	Use dummy cartridges to assure positive functioning Assure that electrical connectors are intact and solenoid functions properly.	Figs. 3-5 and 3-7
		125	Components and Assemblies	Replace defective parts authorized or notify organizational maintenance.	
54			Barrel Assembly	Assure bore is dry and free of obstructions.	
				<b>4-8.1</b>	

Table 4-1. PREVENTIVE-MAINTENANCE CHECKS AND SERVICES

INTERVAL AND SEQUENCE			B - BEFORE OPERATION D - DURING OPERATION A - AFTER OPERATION	REFERENCE	
B	D	A	ITEM TO BE INSPECTED	PROCEDURE	
55		126	Coaxial Machine Gun	Ascertain components are not damaged or missing.	
56			M13A1C Quadrant	<p align="center"><b>SIGHTING AND FIRE CONTROL</b></p> <p>a. Inspect for general condition and completeness. Note legibility of scales and indices; clean as required. Check that level vial rotating cover is in a protected position when quadrant is not in use.</p> <p>b. Check for tightness of screws, binding, legibility of scales, condition of level vial and cover. Check adjustment.</p>	Fig. 2-28 Fig. 2-28
57			Azimuth Indicator	<p>a. Inspect for general condition and completeness. Replace lamp if defective.</p> <p>b. Check for slippage and/or accuracy</p>	Table 5-6 Fig. 2-27
58			M119 or M127 Telescope and M149 Telescope Mount	<p>a. Inspect general condition and completeness. Check that locking lever is in detent position. Inspect headrest. Check operation of diopter adjustment and scale, filter selector lever bore sight knobs, slip scales, and locking lever. Inspect lens and windows for dirt, chips, cracks, and fungus growth. Check electrical connections. Replace lamp if defective.</p> <p>b. Check for parallax and adjust to eliminate if found</p> <p>c. M127 telescope only: Check that dual power selector lever is operable and seats firmly against stops.</p>	Fig. 2-25 Table 5-6 Table 2-9
59			XM44 Series Periscope and	Inspect general condition and completeness. Check operation of knobs and levers. Inspect lens and Control Panel windows for dirt, cracks, and chips. Check electrical connections. Replace lamps if defective. Check periscope washer fluid reservoir and refill.	Fig. 2-26 and Table 5-6
60			Night Vision Sight	<p>a. Inspect all components for dirt, loose, damaged, or worn parts. Focus knobs must operate freely. Objective lens focus knob locking device must have positive locking action. Check eyepiece focus ring for free operation and focusing. If defective, notify organizational maintenance personnel.</p> <p>b. In darkened area, turn rotary control switch clockwise to reticle (second click-stop) position and check for reticle illumination. Continue to rotate rotary control switch clockwise through remaining three reticle lamp positions and check for increasing brightness at each position. If weak or no illumination, replace battery and/or reticle lamp. If no light variation, report condition to organizational maintenance personnel.</p>	Fig. 2-29 and Table 5-6
<b>4-8.2</b>					

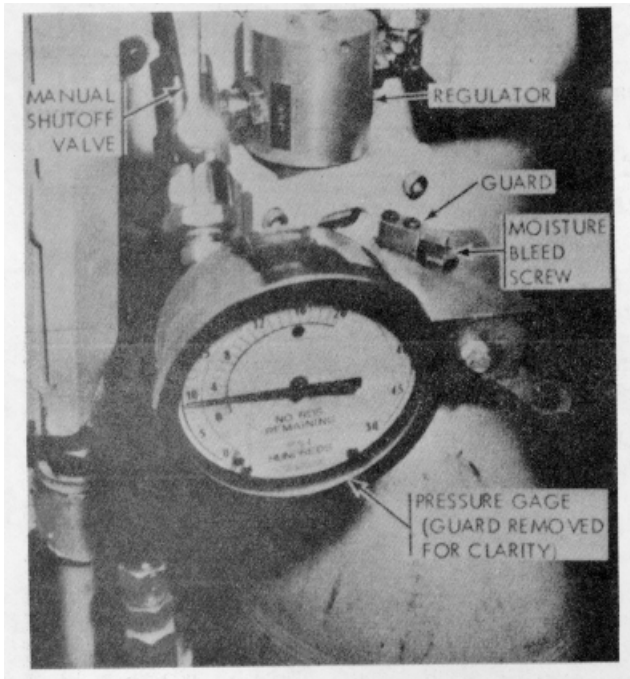

Figure 4-2. Bleeding closed breech scavenger system.

BLEEDING MOISTURE FROM AIR CYLINDERS

1. FOLLOW STEPS 1 THROUGH 4 BELOW FOR BLEEDING AIR PRESSURE FROM SYSTEM.
2. LOOSEN BLEED SCREWS ON TOP OF EACH CYLINDER MANIFOLD TO BLEED MOISTURE FROM CYLINDERS.

**CAUTION:** DO NOT REMOVE OR LOOSEN BLEED SCREW GUARD.

BLEEDING AIR PRESSURE FROM SYSTEM

1. TURN COMPRESSOR SWITCH OFF (FIG. 3-2.3).
2. MANUAL SHUT-OFF VALVE IS TO BE IN OPEN POSITION (FIG. 3-2.4).
3. MAKE SURE GUN-LAUNCHER BREECH IS CLOSED.
4. DEplete AIR SUPPLY BY USING MANUAL LEVER ON THE SOLENOID DISCHARGE VALVE (FIG. 3-234) UNTIL PRESSURE IS REDUCED TO 500 PSI.
5. CONTINUE TO CYCLE MANUAL DISCHARGE LEVER UNTIL PRESSURE IS COMPLETELY DEPLETED.

LEGEND

1. SCREW (2)
2. WASHER (2)
3. ACCESS COVER

USE 9/16" SOCKET TO REMOVE 2 SCREWS. REMOVE 2 WASHERS AND ACCESS COVER TO PROVIDE ACCESS TO HULL FLOOR UNDER TURRET. TRAVERSE TURRET MANUALLY AND REMOVE SPENT BRASS AND OTHER DEBRIS FROM HULL FLOOR. REINSTALL ACCESS COVER AND TIGHTEN SCREWS SECURELY.

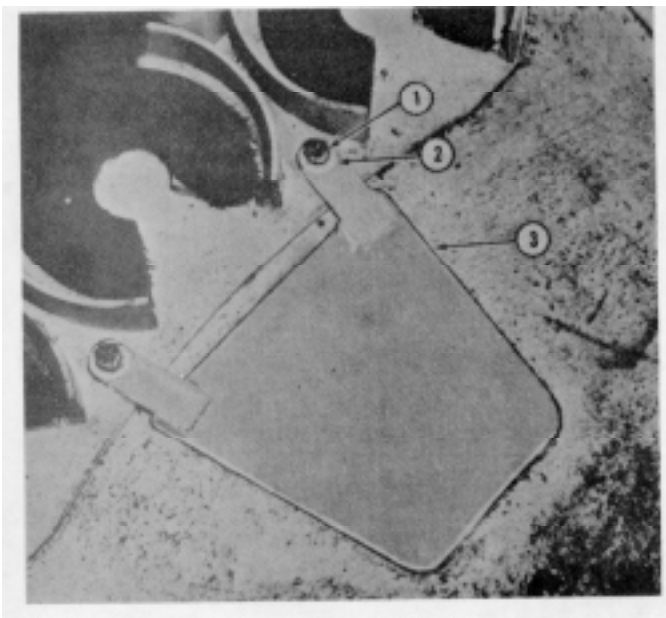

Figure 4-3. Turret floor access cover.

TABLE 4-2. CLEANING CREW COMPARTMENT

STEP	PROCEDURE
1	During cold weather, operate vehicle engine and personnel heater as required to thaw frozen liquids.
2	Remove loose debris from driver's compartment. Remove turret floor access cover if present and remove debris from hull under turret floor (Fig. 4-3).
3	Scrub floor and other dirty areas with detergent and a minimum of water.  <b>CAUTION:</b> 1. <u>Do not use water hose or steam in vehicle interior.</u> 2. <u>Protect all electrical items against wetness (water or solvent).</u>
4	Front bilge pump is normally used to remove liquids from the cleaning operation. However, if front bilge pump is inoperative or inadequate, rear bilge pumps and/or hull access plugs may be used by following steps 5 through 7.
5	Assure that engine bulkhead drain holes are open.
6	Elevate front of vehicle slightly (6 to 10 inches) by driving up an incline or onto timbers or refuse.
7	Operate rear bilge pumps or remove one or more hull access plugs (Fig. 5-7) to evacuate liquids from engine compartment.  <b>CAUTION:</b> Follow instructions in Figure 5-7 when installing access plugs. <b>NOTE:</b> Make sure turret area under compressor is kept clean. Mud or debris in this area can cause compressor motor to short out, resulting in malfunction or damage.

**OPERATING PROCEDURE**

1. COCK ACTUATOR BY PRESSING BUTTON (VIEW A).
2. OPEN BREECH AND INSTALL ACTUATOR FIRMLY SEATED ON FIRING PROBE (VIEW B). CLOSE BREECH.
3. TURN VEHICLE MASTER SWITCH AND TURRET CONTROL SWITCH ON.

**WARNING:** MAKE SURE PERSONNEL ARE CLEAR OF TURRET.

4. TURN FIRE CONTROL SELECTOR TO MISSILE POSITION (FIGURE 2-19).
5. "FIRE" WEAPON ELECTRICALLY WITH COMMANDER'S OR GUNNER'S TURRET CONTROL HANDLE TRIGGER.
6. OPEN BREECH AND CHECK ACTUATOR BUTTON. IF FIRING CIRCUIT IS OPERATING PROPERLY THE BUTTON WILL BE IN TRIPPED POSITION (VIEW C). IF NOT, NOTIFY ORGANIZATIONAL MAINTENANCE.
7. COCK ACTUATOR, CLOSE BREECH, AND REPEAT STEPS 5 AND 6 WITH SELECTOR IN CONV POSITION.
8. COCK ACTUATOR, CLOSE BREECH, AND "FIRE" WEAPON WITH BLASTING MACHINE (F, FIG. 3-1). REPEAT STEP 6, AND REMOVE AND STOW ACTUATOR.

**CAUTION:** ACTUATOR IS DESIGNED FOR USE WITH WEAPONS SYSTEM POWER SOURCES ONLY (MISSILE MODE, CONVENTIONAL MODE, AND BLASTING MACHINE). DO NOT SUBJECT ACTUATOR TO ANY OTHER POWER SOURCE.

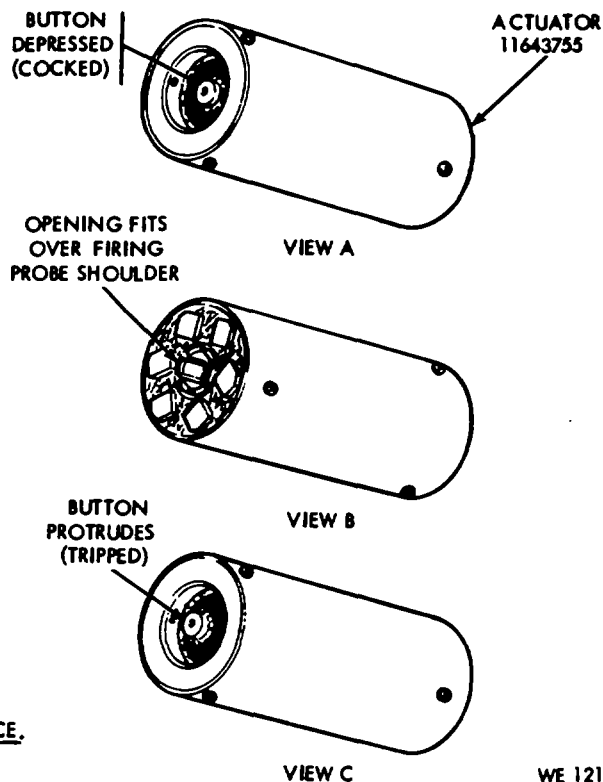

Figure 4-4. Checking firing probe continuity

WE 12170

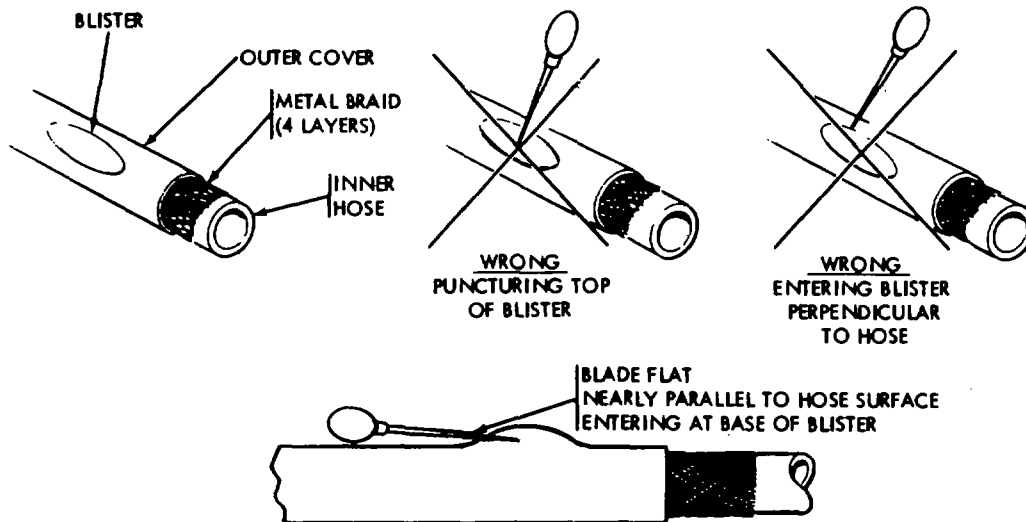
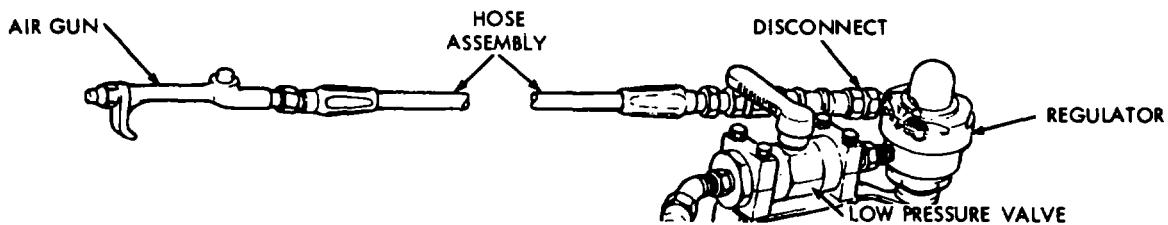

Figure 4-5. Deflating blisters on CBS hose.



**OPERATION OF LOW PRESSURE AIR SYSTEM**

THE LOW PRESSURE AIR SYSTEM IS USED TO CLEAN ENGINE AIR FILTER AND TO CLEAN DEBRIS FROM ENGINE RADIATOR.

OPERATING PROCEDURE IS AS FOLLOWS:

1. CHECK PRESSURE IN CBS SYSTEM. RUN VEHICLE ENGINE AT FAST IDLE AND OPERATE COMPRESSOR TO BUILD SYSTEM PRESSURE TO 3100 PSI (FIG. 3-2.3).

**CAUTION: DO NOT OPERATE ENGINE WITH ENGINE AIR FILTER ELEMENT REMOVED.**

2. CONNECT HOSE TO QUICK-DISCONNECT FITTING ON REGULATOR.
3. TURN CBS AIR SHUTOFF VALVE ON (D, FIG. 3-2.4) AND LOW PRESSURE AIR VALVE ON (HANDLE PARALLEL TO VALVE BODY).

**CLEANING RADIATOR**

1. IF VEHICLE IS EQUIPPED WITH BULKHEAD ACCESS PANEL, OPEN PANEL (FIG. 4-7). OTHERWISE OPEN ENGINE INTAKE GRILLE.
2. BRUSH DEBRIS AND DIRT FROM FACE OF RADIATOR BEFORE APPLYING AIR.
3. HOLD AIR NOZZLE AT APPROXIMATELY 30° ANGLE TO FACE OF RADIATOR FOR BEST RESULTS. PRESS BUTTON ON AIR GUN TO OPERATE.

**CLEANING ENGINE AIR FILTER**

1. ROUTE HOSE THROUGH LOADER'S HATCH TO GROUND AT SIDE OF VEHICLE.

2. REMOVE AND CLEAN ENGINE AIR FILTER (FIG. 5-1)

**CAUTION: AVOID BLOWING DUST INTO ENGINE COMPARTMENT WITH FILTER REMOVED.**

3. AFTER USE, TURN OFF LOW PRESSURE AIR VALVE. DISCONNECT AND STOW HOSE ASSEMBLY IN BATTERY ACCESS COMPARTMENT.

WE 66610

Figure 4-6. Operation of low pressure air radiator cleaning kit

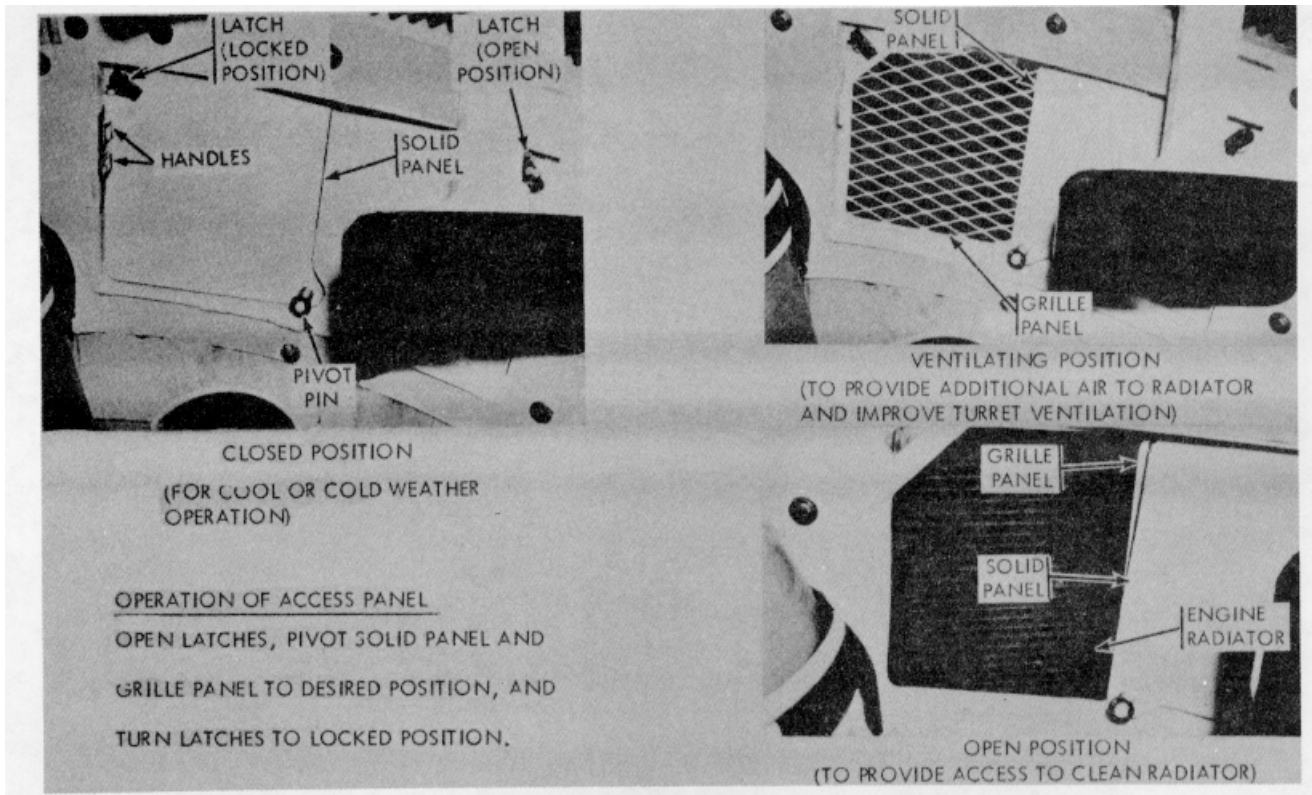

Figure 4-7. Operation of engine bulkhead access panels

4-13/(4-14 Blank)

**CHAPTER 5  
CREW MAINTENANCE**

**Section 5-1. REPAIR PARTS, TOOLS, AND EQUIPMENT**

**5-1. Repair Parts, Tools, and Equipment**

Refer to Appendix II

**Section 5-2. TROUBLESHOOTING**

**5-2. scope**

The following table contains crew troubleshooting of materiel in case of malfunction and the corrective action to be taken.

*Table 5-1. Troubleshooting*

<b>Malfunction</b>	<b>Probable causes</b>	<b>Corrective action</b>
<p>1. Fails to crank, or cranks slowly, when starter is actuated</p> <p>2. Engine cranks but fails to start</p> <p>3. Does not maintain constant speed</p> <p>4. Accelerating improperly</p>	<p>NOTE. For corrective action of malfunctions not listed in this table, refer to organizational maintenance personnel.</p> <p><b>ENGINE</b></p> <p>a. Vehicle MASTER SWITCH not on</p> <p>b. Batteries discharged</p> <p>c. Transmission shift lever not in N (neutral) position</p> <p>d. Loose or corroded battery cable terminals.</p> <p>e. Incorrect oil viscosity for prevailing ambient temperatures</p> <p>f. Internal engine seizure</p> <p>a. Restricted fuel tubes or hoses</p> <p>b. Fuel tanks empty</p> <p>c. Main fuel hose disconnected</p> <p>d. Fuel tank shut-off valves closed</p> <p>e. Fuel shut-off control knob pulled out</p> <p>a. Insufficient fuel</p> <p>b. Water in fuel</p> <p>a. Improper fuel</p> <p>b. Insufficient fuel</p> <p>c. Insufficient air</p>	<p>a. Turn vehicle MASTER SWITCH on (Fig. 2-10)</p> <p>b. Use an external power to start engine (Table 2-5).</p> <p>c. Move to N (neutral) position (F, Fig. 2-6).</p> <p>d. Clean and tighten (0, Fig. 5-3).</p> <p>e. Drain (Fig. 5-7) and refill (A, Fig. 5-2) as specified in LO 9-2350-230-12.</p> <p>f. If engine cannot be rotated one complete revolution, notify organizational maintenance personnel.</p> <p>a. Check for plugged, kinked, or pinched fuel tubes or hoses.</p> <p>b. Check fuel tank gage (Fig.2-9).</p> <p>c. Connect fuel hose (C, Fig. 5-2).</p> <p>d. Open one or both (A, Fig. 5-3).</p> <p>e. Push in fuel shut-off control knob.</p> <p>a. Check fuel lines and filters (Fig. 5-2)</p> <p>b. Drain condensation from fuel filters (C, Fig. 5-2) and fuel tanks (A, Fig. 5-3).</p> <p>a. Drain fuel tanks (Table 5-4) and refill (C, Fig. 5-3) with correct fuel (Par. 1-6).</p> <p>b. Check fuel lines and filters(Fig. 5-2) for leaks.</p> <p>c. Check air cleaner restriction indicator (Fig. 5-1).</p>

Table 5-1. Troubleshooting-Continued

Malfunction	Probable causes	Corrective action
5. Engine overheats	<p><b>ENGINE - Continued</b></p> <p>a. Restricted air passages</p> <p>b. Cooling fan not operating properly</p> <p>c. Drive belts slipping</p> <p>d. Low coolant level</p> <p>e. Malfunction of lubrication system as specified in LO 9-2350-230-12.</p> <p>f. Coolant pump inoperative</p>	<p>a. Check grilles (5,6, Fig. 1-2) and radiator for clogging.</p> <p>b. Check fan operation (Item 2, Fig. 2-9).</p> <p>c. Check tensioner (A, Fig. 5-2).</p> <p>d. Check for leaks and surge tank coolant level (A, Fig. 5-2).</p> <p>e. Check 4U level (A, Fig. 5-) and fill</p>
6. Low or no oil pressure	<p>a. Low oil level</p> <p>b. Improper lubricating oil</p> <p>c. Oil leaks</p>	<p>f. Check belt tensioner (Fig. 5-1.1)</p> <p>a. Replenish (A, 1* 5-2).</p> <p>b. Drain (Fig. 5-7) and refill as specified in LO 9-2350-230-2-1-</p> <p>c. Examine engine compartment Fl.'5-2, for evidence of oil leaks.</p>
7. Transmission does not drive in any range	<p><b>TRANSMISSION</b></p> <p>Low main oil pressure</p>	<p>Check oil level (A, Fig. 5-2) and replenish (LO 9-2350-230-12).</p>
8. No current in battery circuit	<p><b>BATTERIES AND GENERATING SYSTEM</b></p> <p>a. Loose cable connections</p> <p>b. Dead batteries</p> <p>c. Discharged batteries</p>	<p>a. inspect, clean, and tighten cables and connection at battery O), Fig. 5-3) and master relay.</p> <p>b. Replace or charge batteries.</p> <p>c. Check batteries (D, Fig. 5-3).</p>
9. Batteries do not stay charged	<p>Excessive use of electrical equipment when engine is not running</p>	<p>Discourage prolonged usage of electrical equipment without engine running</p>
10. Vehicle MASTER SWITCH indicator lamp does not light.	<p>a. MASTER 8W1TCH not on</p> <p>b. Lamp burned out</p> <p>c. Loose electrical leads</p>	<p>a. Turn MASTER SWITCH on (Fig. 2-10).</p> <p>b. Replace (Table 5-3).</p> <p>c. Inspect and tighten connection if required</p>
11. Vehicle pulls to one side with Steer bar in center position.	<p><b>TRACKS AND SUSPENSION</b></p> <p>a. Improper track tension</p>	<p>at Adjust (Fig. 5-4).</p>
12. Vehicle thrown track	<p>b. Build-up of mud or dirt on one track</p> <p>a. Improper driving or operation of vehicle</p> <p>b. Excessively loose or worn track</p>	<p>b. Clean.</p> <p>a. Improper driving methods. Do not make high speed turns.</p> <p>b. Adjust track tension (Fig. 5-4).</p>
13. Heater fails to start	<p><b>PERSONNEL HEATER</b></p> <p>Incorrect operating procedure</p>	<p>Refer to operating procedure (Fig. 2-17 .</p>
14. Heat exchanger load up with soot and carbon	<p>a. Too heavy grade of fuel oil for ambient condition</p> <p>b. Restriction in exhaust</p>	<p>a. Improper grade of fuel oil (LO 9-2350-2330-12).</p> <p>b. Remove restriction (4, Fig. 1-2).</p>



Table 5-1. Troubleshooting-Continued

Malfunction	Probable causes	Corrective action
15 Bilge pump does not operate with bilge pump switch turned on	<p align="center"><b>BILGE PUMP</b></p> <p>a. Vehicle MASTER SWITCH off b. Loose electrical leads at circuit breaker, relay, or switch panel</p>	<p>a. Turn MASTER SWITCH on (fig 2-10). b. Inspect and tighten connectors if required.</p>
16 Failure to fire conventional ammunition or missile (READY lamps on).	<p align="center"><b>152tM GUN-LAUNCHER</b></p> <p>Defective ammunition or electrical malfunction</p>	<p>Refer to immediate action in case of failure to fire (table 3-1).</p>
17 Failure of loader's control box or reticle dimmer box READY lamps to illuminate high or too low.	<p>a. READY lamp defective inoperative (fig 2-25 and A, fig 3-1). b. Recoil mechanism pressure too</p>	<p>a. Press to test lamp and replace if in- b. Adjust pressure (fig 3-2).</p>
17.1 Smoke and fumes discharging from cover of breech.	<p>c. Gun out of battery</p>	<p>c. Check safe-to-fire indicator rod (fig 3-2) Increase pressure if required. Notify organizational maintenance.</p>
17.2. Smoke and/or flame discharging from tube lock key or detent assembly vent	<p>Erosion past firing probe</p>	<p>Notify supporting maintenance.</p>
18. Breech chamber will not rotate into fully closed position	<p>Malfunctioning seal; erosion or corrosion of detent assembly or cannon detent hole.</p>	
18. Replenisher hand pump does not increase recoil mechanism pressure 30. Gun-Launcher returns to battery with excessive force	<p align="center"><b>152MM GUN-LAUNCHER MOUNT</b></p> <p>a. Obstruction or foreign material between buttress threads or between chamber and tube face. b. Foreign material inside of breech chamber</p>	<p>a. Manually open breech and remove obstruction or foreign material. b. Manually open breech and clean Interior of breech chamber. Check operation of scavenging system. Replenish reservoir (Fig. 3-2) and check for excessive recoil oil leak- age.</p>
19. Replenisher hand pump does not increase recoil mechanism pressure	<p>Insufficient fluid in reservoir</p>	<p>Add fluid (Fig. 5-9).</p>
21. Excessive effort required to manually elevate or depress	<p>Insufficient fluid in counter-recoil buffer.</p>	
22. Elevating system electric drive inoperative with palm switch depressed	<p align="center"><b>GUN-LAUNCHER ELEVATING AND TURRET TRAVERSING SYSTEMS</b></p> <p>a. Excessive load due to binding or obstruction in shield area or gear box. b. Contaminated lubricant on elevating mechanism pivots.</p>	<p>a. Remove obstruction. b. Clean and lubricate (LO 9-2350-230-12).</p>
23. Creeps excessively, after war up, in elevation, depression, and azimuth with control handles in neutral position.	<p>a. Vehicle MASTER SWITCH not on b. TURRET CONTROL POWER switch not on. c. Loose electrical connectors Elevation and/or azimuth trim buttons out of adjustment</p>	<p>Turn MASTER SWITCH on(Fig. 2-10). b. Turn POWER switch on (Fig. 2-19). c. Tighten electrical connectors. Adjust gunner's and/or commander's trim button (Figs. 2-19, 21).</p>
24. Excessive "dead" space in either control handle when elevating or depressing.	<p>a. Excessive load, due to binding or obstruction in shield area. b. Contaminated lubricant on elevating mechanism pivots.</p>	<p>a. Remove obstruction. b. Clean and lubricate (LO9-2350-230-12)</p>
24. 1. Palm switch energized without being depressed	<p>Dirt collected under heel of palm switch</p>	<p>Depress palm switch and remove dirt with thin bladed tool</p>

Table 5-1. Troubleshooting-Continued

Malfunction	Probable causes	Corrective action
<p>25. Traversing system electric drive inoperative with palm switch depressed.</p> <p>26. Turret will not power traverse in either direction.</p> <p>27. Traverse or elevation servo motors overheat during operation.</p> <p>28. Motor-Generator does not operate with control handle palm switches depressed</p> <p>c. Loose wiring harness connections at motor-generator.</p> <p>29. Cupola sluggish in electrical power position</p> <p>30. Power rotation in one direction only with or without pushing direction switch.</p> <p>31. No rotation</p> <p><b>CAUTION: If humming noise is heard from motor with POWER switch in ON position turn to OFF position, and notify organizational maintenance.</b></p> <p>32. Failure to feed</p> <p>33. Failure to chamber</p>	<p><b>GUN-LAUNCHER ELEVATING AND TURRET TRAVERSING SYSTEMS - Continued</b></p> <p>a. Vehicle MASTER SWITCH not on</p> <p>b. TURRET CONTROL POWER switch not on.</p> <p>c. Loose electrical connectors Turret traverse lock engaged</p> <p>Excessive load, due to obstructions or foreign matter in turret ring gear.</p> <p>a. Vehicle MASTER SWITCH not on</p> <p>b. TURRET CONTROL POWER switch not on.</p> <p>c. Tighten connections (F, Fig. 2-20).</p> <p><b>POWER ASSIST CUPOLA</b></p> <p>Excessive foreign matter in bearing or ring gear.</p> <p>Loose connections at control assembly</p> <p>a. No electrical power</p> <p>b. Foreign matter in slip ring</p> <p>c. Loose connections at control assembly (Table 5-9).</p> <p><b>7.62MM MACHINE GUN</b></p> <p>a. Defective link or ammunition</p> <p>b. Defective driving stud,</p> <p>c. Cover unlatched</p> <p>d. Feed system improperly loaded</p> <p>e. Gun improperly loaded</p> <p>a. Defective ammunition.(Short-round)</p> <p>b. Ammunition belt installed upside down.</p> <p>c. Defective driving springs</p> <p>d. Defective cartridge rammer</p> <p>e. Obstruction by foreign substances or material in chamber.</p> <p>f. Defective rammer actuator roller</p>	<p>a. Turn MASTER SWITCH on (Fig. 2-10).</p> <p>b. Turn POWER switch on (Fig. 2-19).</p> <p>c. Tighten electrical connectors. Disengage (C, Fig. 2-20).</p> <p>Remove obstructions.</p> <p>a. Turn MASTER SWITCH on (Fig. 2-10).</p> <p>b. Turn POWER switch on (Fig. 2-19).</p> <p>Clean (B, Fig. 2-20).</p> <p>Check (3, Fig. 2-21).</p> <p>a. Turn cupola control assembly POWER switch to ON position (3, Fig. 2-21) .</p> <p>b. Remove matter and clean.</p> <p>c. Check (3, Fig. 2-21).</p> <p>a. Remove faulty link and/or round.</p> <p>b. Replace barrel extension assembly.</p> <p>c. Close cover.</p> <p>d. Open door on ammunition feed box (A, Fig. 3-5) and make sure link belt is properly looped and is not kinked.</p> <p>e. Load according to Table 3-5.</p> <p>a. Replace faulty round.</p> <p>b. Install belt properly.</p> <p>c. Replace springs.</p> <p>d. Replace barrel extension assembly.</p> <p>e. Remove obstructing matter.</p> <p>f. Replace barrel extension assembly.</p>

Table 5-1. Troubleshooting-Continued 6,

Malfunction	Probable causes	Corrective action
<b>7.62MM MACHINE GUN Continued</b>		
34. Failure to lock	a. Breechblock assembly incorrectly installed.	a. Install properly.
	b. Defective breechblock roller and/or shaft.	b. Replace breechblock assembly.
	c. Barrel Installed incorrectly. Not engaged in barrel extension or upside down.	c. Install barrel properly.
	d. Defective lever actuator (breech - closing) roller.	d. Replace barrel extension assembly.
35. Failure to fire	a. Fire control selector not in CQAX position.	a. Turn to COAX position (Fig. 2-19).
	b. Defective barrel extension assembly	b. Replace.
	c. Defective firing pin	c. Replace breechblock assembly.
	d. Defective firing pin extension	Replace barrel extension assembly.
	e. Loose connector	e. Inspect electrical harness.
	f. Safety in ('S" position	f. Slide safety to ("F" position.
	g. Defective ammunition	g. Remove faulty round.
36. Failure to unlock	Defective lever actuator (breech - opening) roller.	Replace barrel extension assembly.
37. Failure to extract	a. Defective cartridge case (rim ruptured)	a. Remove spent case (Fig. 3-6).
	b. Defective extractor	b. Replace barrel extension assembly.
	c. Defective cartridge rammer	c. Replace barrel extension assembly.
	d. Defective extractor spring	d. Replace barrel extension assembly.
	e. Pitted chamber	e. Replace barrel assembly.
	f. Short recoil	f. Investigate for binding parts, clean and lubricate (LO 9-2350-230-12).
38. Failure to eject	Defective barrel extension assembly	Replace.
39. Failure to cock	Defective barrel extension assembly	Replace.
40. Uncontrolled automatic fire	a. Defective barrel extension (sear notches).	a. Replace.
	b. Defective receiver tabs	b. Notify organizational maintenance.
41. Improper rate control	Missing rate control pawl	Replace barrel extension assembly.
42. Failure to load	a. Ammunition placed in feedway incorrectly.	a. Reposition ammunition belt.
	b. Link from previous belt in feedway	b. Remove expended (last) link.
43. Failure to feed	<b>CAL. .50 MACHINE GUN, M2 (Table 5-10)</b> Defective ammunition belt	Remove damaged link or reposition rounds.
44. Failure to chamber	Damaged round, obstruction in T-slot, or ruptured case.	Remove round and clean T-slot.
45. Failure to lock	a. Broken or damaged parts	a. Examine for broken parts, battered breech lock or rough breech lock cam.

Table 5-1. Troubleshooting-Continued

Malfunction	Probable cause	Corrective action
	<b>CAL 50 MACHINE GUN, M2 (Table 5-10) Continued</b>	
45. Failure to lock - Continued	b. Insufficient headspace	b. Adjust (Table 3-7).
46. Failure to fire	a. Defective ammunition	a. Remove and insert new ammunition.
	b. Incorrect timing	b. Adjust (Table 3-8).
47. Failure to extract	a. Dirty chamber	a. Clean.
	b. Broken extractor	b. Replace bolt assembly.
48. Failure to cock	a. Broken sear	a. Replace bolt assembly.
	b. Worn sear notch	b. Replace bolt assembly.
	c. Weak sear spring	c. Replace bolt assembly.
	d. Worn hooked notch on firing pin extension.	d. Replace bolt assembly.
49. Failure to eject	a. Defective ejector	a. Replace bolt assembly.
	b. Obstructed T-slot in bolt assembly	b. Remove obstruction.
	<b>M37, M47 AND M48 PERISCOPES</b>	
50. Poor visibility	a. Dirty optical surface	a. Clean optical surfaces with lens tissues (A, Fig. 5-8).
	b. Condensation (M47 and M48 only)	b. Refer to TM 750-116
	<b>M48 PERISCOPE</b>	
51. Foggy or no infrared vision	a. Periscope power switch not on	a. Check power switch on periscope (A, Fig. 5-8).
	b. Weak or dead cell if operating from battery.	b. Replace 1-1/2 volt cell (A, Fig. 5-8)
	c. No infrared illumination	c. Check target area with another IR viewing instrument .
52. No fluid from periscope washer assembly	a. No fluid in reservoir	a. Refill reservoir (Fig. 2-7).
53. Periscope loose after installation.	b. Clogged tubing	b. Clean tubing or nozzle.
	Loose mount assembly	Tighten mount assembly bolts (2-12).
54. Flickering infrared image	a. Loose or poor connection	a. Check electrical connection (Fig. 2-7).
	b. Flickering infrared illumination	b. Report condition to organizational maintenance personnel.
	<b>XM44 SERIES PERISCOPE</b>	
55. Loss of boresight	Boresight knobs not fully engaged	Check knobs to insure firm engagement with clutch teeth (Fig. 2-26).
56. Poor or no reticle illumination	a. Periscope power supply ON, OFF switch in OFF position	a. Turn power supply switch to ON position (17, Fig. 2-26).
	b. Defective lamp)	b. Replace lamp (Table 5-6).
	c. Loose or broken connection	c. Check all connections on control panel.

Table 5-1. Troubleshooting-Continued

Malfunction	Probable cause	Corrective action
<b>XM44 SERIES PERISCOPE - Continued</b>		
56. Poor or no reticle illumination - Continued	d. RETICLE LOGHT intensity control rheostat knob on control panel is in OFF position.	d. Rotate RETICLE LIGHT rheostat knob (4, Fig. 2-26).
57. Daylight vision foggy	a. Dirt or fingerprints on optical elements. b. Condensation	a. Clean with lens tissue. b. XM44: Refer to TM 750-116. XM44E Series: Notify Organizational Maintenance.
58. Foggy image in focal plane at screen end of image intensifier tube	a. Dirt or fingerprints on optical elements. b. Improper focus	a. Clean with lens tissue. b. Make initial adjustment of image at image intensifier tube by turning diopter knob. Make final focal adjustment by turning focus knob.
58. 1 Inability to focus	c. Insufficient light in field of view d. Filter aperture not suitable for proper illumination of image Image intensifier tube with related parts improperly assembled and/or installed.	c. Resight periscope and/or main gun to obtain more light in field of view. d. Adjust filter lever to proper catch on adapter (21, Fig. 2-26). Notify organizational maintenance.
59. Control panel indicator light does not illuminate.	Defective lamp	Replace lamp (Table 5-6).
60. No image	a. Vehicle MASTER SWITCH turned off b. Periscope ON/OFF switch in OFF position.	a. Turn MASTER SWITCH on (Fig. 2-10). b. Turn to ON position (17, Fig. 2-26).
61. Excessive illumination in image	Wrong filter aperture	Adjust filter lever to obtain proper filter aperture (21, Fig. 2-26).
<b>M119 OR M127 TELESCOPE</b>		
62. Poor definition of field of view (image not sharp and clear)	a. Eyepiece not focused correctly for operator b. Dirty external optics c. Condensation	a. Rotate diopter knob until image is sharp and clear (2, Fig. 2-25). b. Clean external optics. c. Refer to TM 750-116.
63. Poor or no reticle illumination	a. Improperly adjusted reticle light control b. Defective lamps c. Lack of electrical power to telescope	a. Adjust reticle light rheostat (1, Fig. 2-25). b. Replace lamps (Table 5-6). c. Check plugs and receptacle from instrument to reticle dimmer box and power source for proper mating. Replace checksight lamp (Table 5-6).
64. No checksight light beam	Burned out or defective lamp	Replace checksight lamp (Table 5-6).
<b>AZIMUTH INDICATOR</b>		
65. Scales not illuminated	a. Lack of electrical power b. Defective lamp	a. Check electrical connections (Fig. 2-27). b. Replace lamp (Table 5-6).

Table 5-1. Troubleshooting-Continued

Malfunction	Probable cause	Corrective action
<b>M13A1C QUADRANT</b>		
66. Zero graduations on elevation scale and micrometer scale do not coincide	a. Loose elevation knob  b. Loose elevation scale mounting screws.	a. Level gun with M1A1 quadrant and align M13A1C quadrant micrometer (Fig. 2-28), and tighten screws.  b. Align scale (Fig. 2-28) and tighten screws.
67. With level bubble centered, elevation scale and micrometer scale readings are not zero.	Scales improperly adjusted	Adjust scales (Fig. 2-28).
<b>MISSILE SUBSYSTEM TEST CHECKOUT PANEL</b>		
68. All lamps do not illuminate when LAMP AND METER TEST switch is held.	Defective lamps	Replace lamps (Table 5-6).
69. SIG DATA CONV lamp glows at end of self-test (Table 2-12).	a. ALIGN and ERROR levers in wrong position or tracker not aligned  b. Checksight lamp defective	a. Place levers in correct position and/or perform tracker alignment  b. When performing tracker alignment make certain checksight light is visible. Replace lamp if necessary and repeat subsystem checkout procedures (Tables 2-12 and 5-6).
70. POWER SUPPLY lamp glows at end of self-test	Low power from vehicle	If vehicle engine is off, start engine, set idle speed to 750-rpm and repeat subsystem checkout procedures (Table 2-12).
71. TRACKER lamp glows at end of self-test	Tracker not properly aligned	Perform tracker alignment procedure (Table 2-12). Repeat subsystem checkout procedure.
<b>NIGHT VISION SIGHT</b>		
72. No illumination of reticle	a. Weak or dead battery  b. Defective reticle lamp	a. Replace battery (B, Fig. 5-8).  b. Replace lamp (Table 5-6).
73. Weak or no illumination of image intensifier tube or image blurred.	a. Objective lens or eyepiece lens dirty or fogged.  b. Objective lens out of focus c. Eyepiece out of focus d. Dead or weak battery	a. Clean lenses.  b. Adjust lens focus (Table 2-11). c. Adjust eyepiece focus (Table 2-11). d. Replace battery (B, Fig. 5-8).

## Section 5-3. MAINTENANCE OF HULL

## 5-3. Crew Maintenance Instructions

The following tables and illustrations provide hull maintenance instructions to be performed by the crew.

TABLE 5-2. CREW MAINTENANCE - HULL

ITEM	INSPECT	SERVICE	ADJUST	INSTALL	REPLACE
Engine Air Cleaner and Restriction Indicator	Fig. 5-1	Fig. 5-1			
Generator "V" Belt Tensioner	A, Fig. 5-2				
Coolant Pump Belt Tensioner	Fig. 5-1.1				
Fuel System:					
Fill		C, Fig. 5-3			
Drain		Table 5-4			
Center Fuel Tank		A, Fig. 5-3			
Engine Lubricant:					
Fill (LO 9-2350-230-12)		A, Fig. 5-2			
Drain		3, Fig. 5-7			
Transmission Lubricant:					
Fill (LO 9-2350-230-12)		A, Fig. 5-2			
Drain		5, Fig. 5-7			
Coolant System:					
Fill		A, Fig. 5-2			
Drain		Table 5-4			
Battery		D, Fig. 5-3			
Lamps					Table 5-3
Engine Fuel Filters		C, Fig. 5-2			
Track			Fig. 5-4	Fig. 5-5	
Engine Breather Drain Collector Box		B, Fig. 5-3			
Driver's Periscope Washer Liquid Reservoir		Fig. 2-7			
Accumulator		Fig. 2-14			
Bilge Pump		Fig. 2-13			

**NOTE.** For General Cleaning Procedure, refer to TM 9-208-1 and TM 9-247.

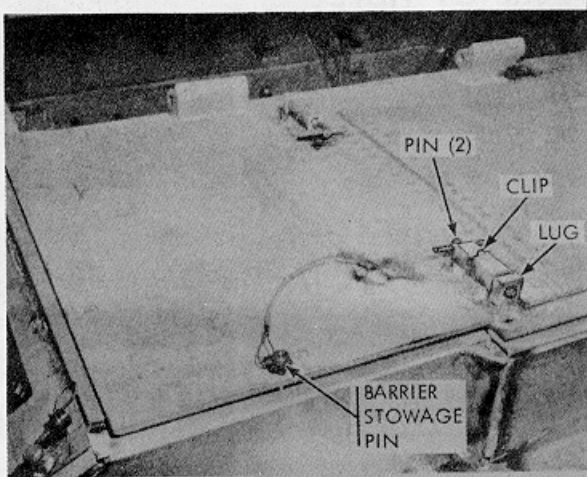

COVER DOORS EFFECTIVE VEHICLE SN 1293

TO OPEN COVER DOOR.

1. PULL BARRIER STOWAGE PIN.
2. EARLY VEHICLES: PULL PIN COMPLETELY OUT OF LUGS AND BLOCKS.  
LATER VEHICLES: PULL PINS OUT OF LUGS (DO NOT REMOVE CLIP).
3. FOLD COVER DOOR AT HINGES.

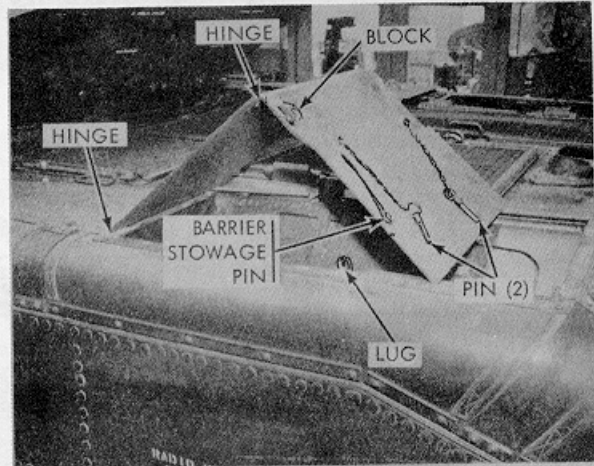

COVER DOORS - VEHICLES PRIOR TO SN 1293

TO LOCK COVER DOOR

1. CLOSE DOOR.
2. INSERT PINS THROUGH BLOCKS AND LUGS (EARLY VEHICLES) OR PUSH PINS THROUGH LUGS (LATER VEHICLES).
3. INSTALL BARRIER STOWAGE PIN.

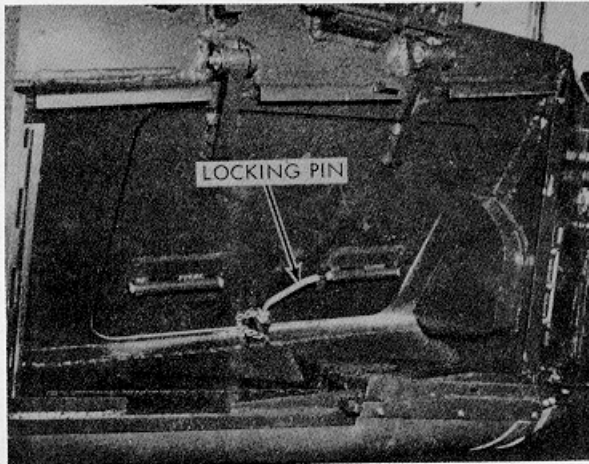

AIR CLEANER ACCESS DOOR

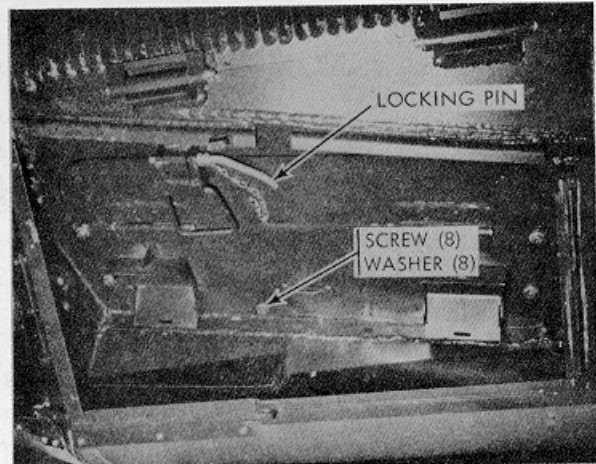

BATTERY ACCESS DOOR

TO SERVICE AIR CLEANER, PULL LOCKING PIN AND OPEN HINGED DOOR.

**NOTE.** RESTRICTION INDICATOR (FIG. 5-1) CAN ALSO BE CHECKED BY OPENING ENGINE LEFT EXHAUST GRILLE.

CLOSE DOOR AND INSTALL LOCKING PIN AFTER SERVICING.

TO SERVICE BATTERY, PULL LOCKING PIN AND OPEN HINGED SECTION OF DOOR.

TO REMOVE BATTERIES NOTIFY ORGANIZATIONAL MAINTENANCE.

CLOSE DOOR AND INSTALL LOCKING PIN AFTER SERVICING.

WE 66598

Figure 5-0. Battery and air cleaner cover and access doors



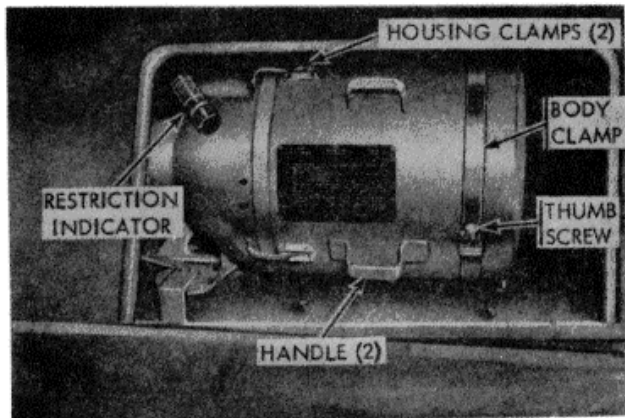

EARLY VEHICLES

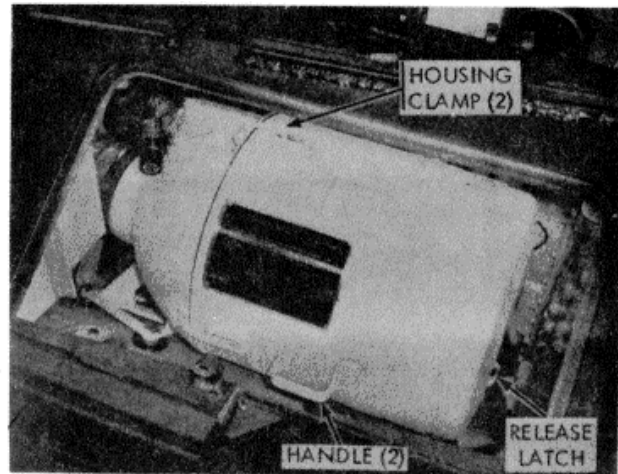

LATER VEHICLES

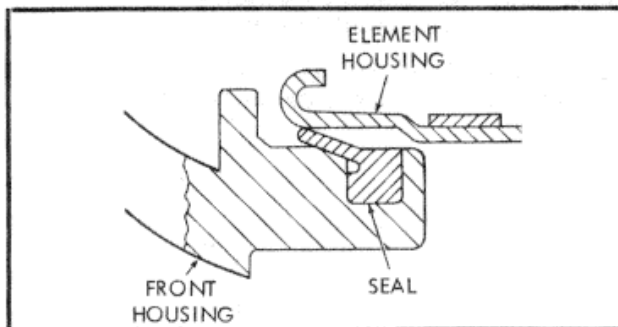

ALL VEHICLES

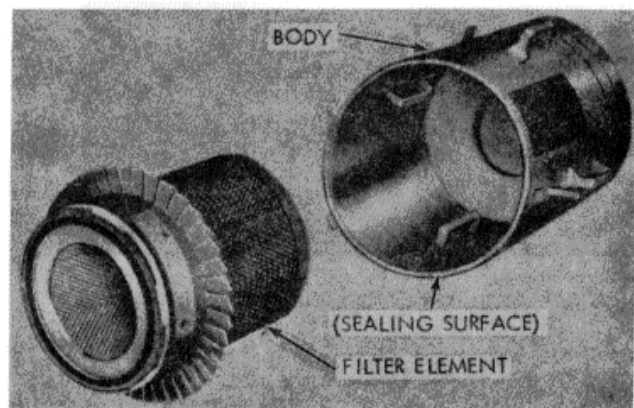

ALL VEHICLES

PRELIMINARY STEPS

- A. RESTRICTION INDICATOR MAY BE CHECKED FROM ENGINE COMPARTMENT BY OPENING LEFT ENGINE COMPARTMENT EXHAUST GRILLE.
- B. IF SERVICE IS REQUIRED, OPEN AIR CLEANER ACCESS DOORS (FIG. 5-0).
- C. FOLLOW INSTRUCTIONS ON HOUSING TO REMOVE FILTER FOR SERVICING.

AIR CLEANER SERVICING PROCEDURE

1. AIR CLEANER SHOULD BE SERVICED WHENEVER RESTRICTION INDICATOR LOCKS IN TOP-MOST RED POSITION. NOTE THAT INDICATOR WILL SHOW A LITTLE RED WHEN AIR CLEANER IS PARTLY RESTRICTED AND WILL SHOW MAXIMUM RED INDICATING FULL RESTRICTION AND REQUIRED SERVICING.
2. EMERGENCY SERVICING OF AIR CLEANER IN ABSENCE OF COMPRESSED AIR OR WATER CAN BE ACCOMPLISHED BY EMPTYING LOWER PORTION (DUST CUP) AND GENTLY TAPPING AIR CLEANER ELEMENT (CARTRIDGE) WITH HANDS. IT IS NOT NECESSARY TO POUND ELEMENT AS ENOUGH DUST WILL BE REMOVED BY TAPPING TO ALLOW VEHICLE TO PROCEED TO A SOURCE OF COMPRESSED AIR OR A FACILITY TO WASH ELEMENT.
3. NORMAL SERVICING OF THE AIR CLEANER IS ACCOMPLISHED BY EMPTYING LOWER PORTION AND CLEANING ELEMENT WITH COMPRESSED AIR (100 PSI MAX.) AS FOLLOWS:
  - a. DIRECT A STREAM OF COMPRESSED AIR AGAINST INSIDE (DOWN STREAM SIDE) OF ELEMENT USING BACK AND FORTH MOTION.
  - b. REPEAT PROCEDURE FOR OUTSIDE (UP STREAM SIDE) OF ELEMENT.
  - c. COMPLETE THE CLEANING BY REPEATING PROCEDURE FOR INSIDE OF ELEMENT TO REMOVE ANY DIRT ON THE CLEAN AIR SIDE THAT MAY HAVE BLOWN IN WHEN OUTSIDE OF ELEMENT WAS CLEANED.
4. OPTIONAL SERVICING OF AIR CLEANER WHEN COMPRESSED AIR IS NOT AVAILABLE OR WHEN ELEMENT HAS BECOME CAKED WITH DUST OR SOILED WITH SOOT IS ACCOMPLISHED BY EMPTYING LOWER PORTION AND CLEANING ELEMENT WITH WATER AS FOLLOWS:
  - a. SUBMERGE AND AGITATE ELEMENT IN A WATER AND NON-SUDSING DETERGENT OR SOAP SOLUTION.
  - b. RINSE THOROUGHLY, PARTICULARLY IF SOAP IS USED.
  - c. DRY BEFORE INSTALLING IN AIR CLEANER. UNDER EMERGENCY CONDITIONS ELEMENT CAN BE REINSTALLED IN AIR CLEANER AFTER ONLY A FIVE MINUTE DRIP PERIOD. ENGINE SHOULD BE IDLED FOR A SHORT TIME TO COMPLETE THE DRYING PRIOR TO OPERATION UNDER DUSTY CONDITIONS.
5. ELEMENT MUST NOT BE CLEANED IN GASOLINE OR OTHER PETROLEUM SOLVENTS.
6. BEFORE REASSEMBLY, ELEMENT SEAL, BODY SEAL, AND ELEMENT FABRIC SHOULD BE CHECKED FOR DAMAGE AND REPLACED IF REQUIRED.

WE 66597

Figure 5-1. Servicing engine air cleaner

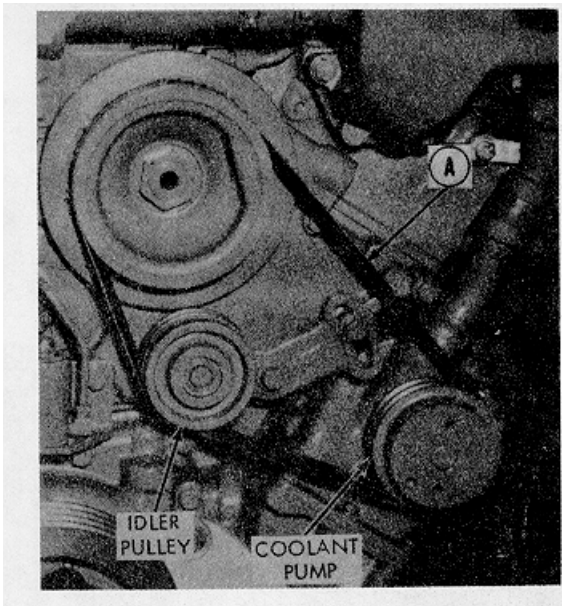

CHECK BELTS FOR BREAKS AND FOR EXCESSIVE WEAR.

CHECK BELT TENSION. PROPERLY ADJUSTED BELTS CAN BE DEPRESSED APPROXIMATELY 1/4 INCH BY APPLYING 5 TO 10 POUNDS PRESSURE AT POINT "A".

IF BELTS ARE BROKEN OR EXCESSIVELY WORN, OR ARE IN NEED OF ADJUSTMENT, NOTIFY ORGANIZATIONAL MAINTENANCE.

WE 119501

*Figure 5-1.1. Checking coolant pump belts*

**5-10.2**

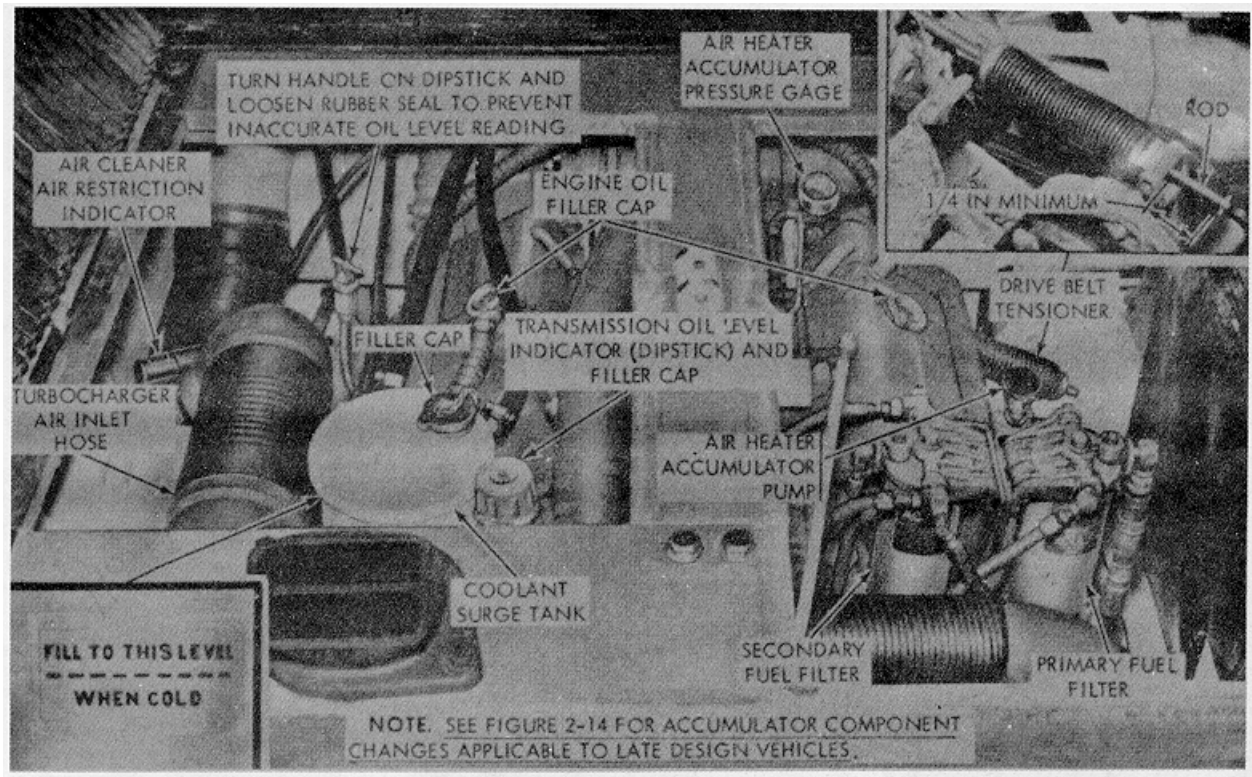

A. ENGINE COMPARTMENT

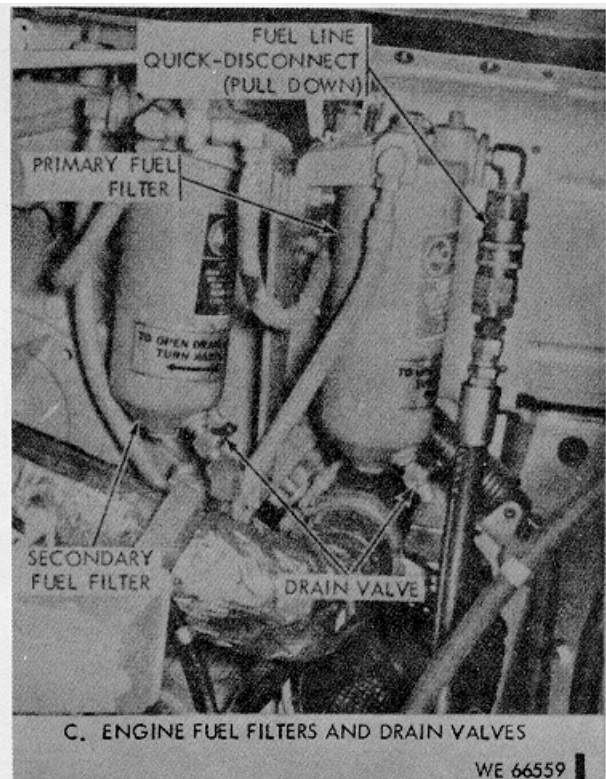
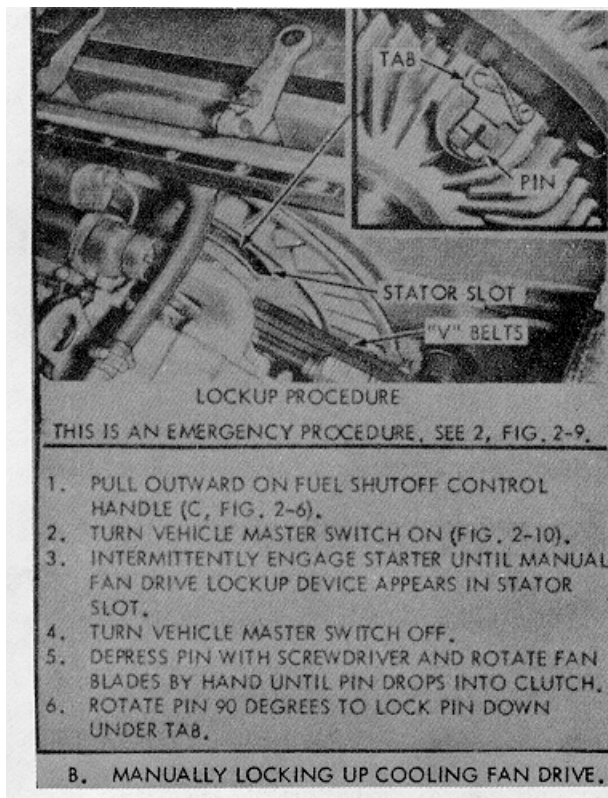
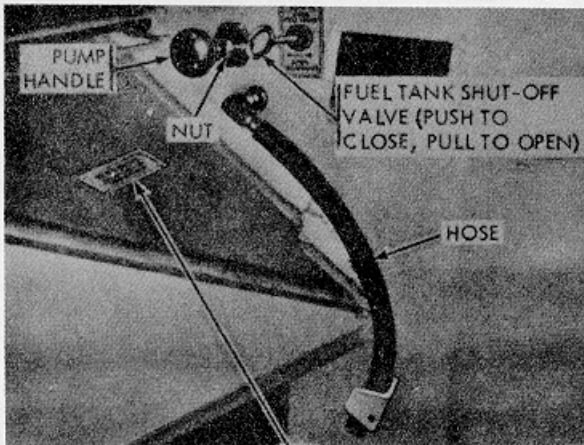
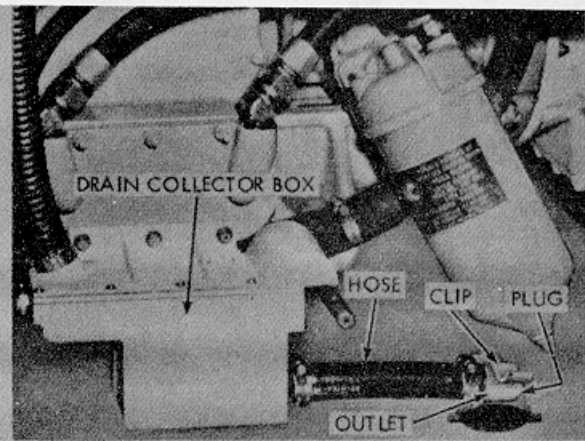

Figure 5-2. Engine compartment, fan drive manual lockup device, and engine fuel filters



**FUEL DRAIN PUMP**  
 REMOVE NUT AT BASE OF HANDLE TO OPERATE. PLACE HOSE IN CONTAINER BEFORE PUMPING. IMPORTANT - STORE HOSE AND TIGHTEN NUT WHEN FINISHED.

A. DRAINING CONDENSATION FROM CENTER FUEL TANK. IF PUMP FAILS TO OPERATE PROPERLY, NOTIFY ORGANIZATIONAL MAINTENANCE TO CHECK FUEL DRAIN PUMP FILTER AND PUMP ASSEMBLY (FIGURE 9-18, ITEMS 15 AND 6).



B. DRAINING ENGINE BREATHER DRAIN COLLECTOR BOX.

STEP	PROCEDURE
1	REMOVE ENGINE OIL FILTER ACCESS PLUG FROM BOTTOM OF HULL (3, FIG. 5-7).
2	REMOVE OUTLET FROM CLIP.
3	REMOVE OUTLET PLUG AND DRAIN CONDENSATION FROM DRAIN COLLECTOR BOX.

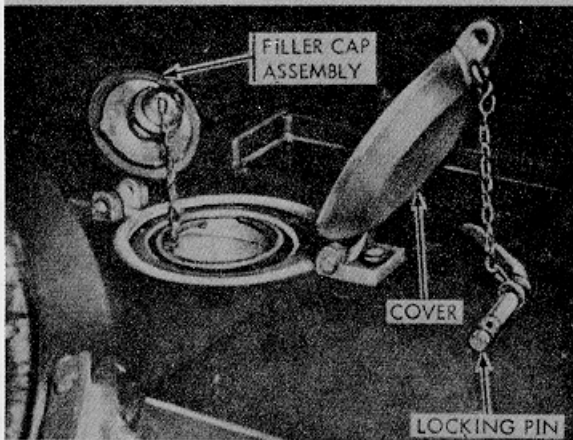

**NOTE.** 1. LEFT AND RIGHT FUEL FILLER CAPS MUST BE REMOVED TO INSURE PROPER VENTING.  
 2. REFER TO PARAGRAPH 1-6, C FOR FUEL TANK ACCEPTANCE RATE AND TYPES OF FUEL USED.

C. ADDING FUEL.

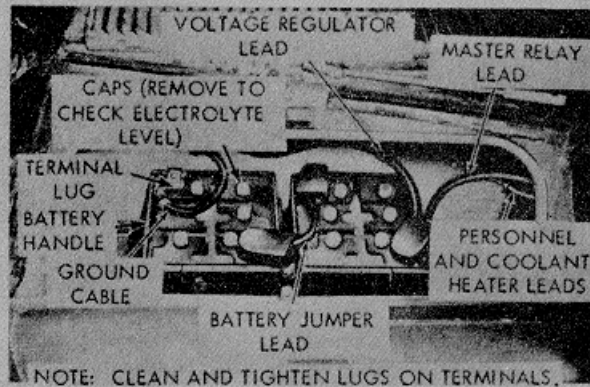

**NOTE:** CLEAN AND TIGHTEN LUGS ON TERMINALS.

D. CHECKING AND SERVICING BATTERIES.

STEP	PROCEDURE
1.	PULL OUT 2 PINS AND OPEN ACCESS DOOR COVER, FIG. 1-2.
2	PULL OUT LOCKING PIN AND OPEN BATTERY ACCESS DOOR.

WE 108948

Figure 5-3. Fuel filler cap, batteries, center fuel tank drain pump, and engine breather drain collector box



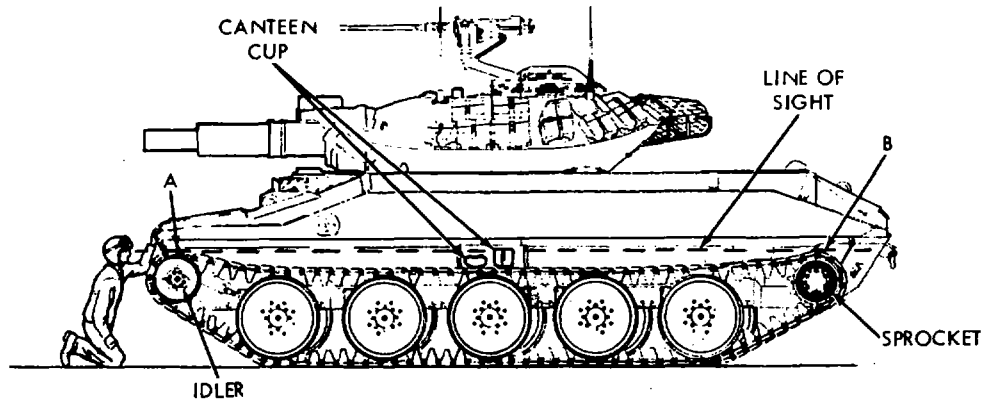

A. CHECKING TRACK TENSION

### CHECKING TRACK TENSION

SAG IN TRACK BETWEEN IDLER AND SPROCKET MUST BE KEPT BETWEEN 3-1/2 AND 4 INCHES. CHECK TRACK TENSION BEFORE AND AFTER VEHICLE OPERATION AS FOLLOWS:

1. PLACE CANTEEN DRINKING CUP FLAT (3-1/2" DIMENSION) ON TRACK DIRECTLY OVER NO. 3 ROADWHEEL.
2. LIFT FRONT MUD GUARD AND SIGHT FROM POINT A (TOP OF TRACK ON IDLER) TO POINT B (TOP OF TRACK ON SPROCKET).
  - a. IF TOP OF CANTEEN CUP COINCIDES WITH LINE OF SIGHT, TRACK ADJUSTMENT IS CORRECT.
  - b. IF TOP OF CANTEEN CUP OBSCURES LINE OF SIGHT, TRACK IS TOO TIGHT. DECREASE TRACK TENSION AS REQUIRED.
  - c. IF TOP OF CANTEEN CUP IS BELOW LINE OF SIGHT, TRACK MAY BE TOO LOOSE. CHECK BY FOLLOWING STEP 3.
3. PLACE CANTEEN CUP UPRIGHT (4" DIMENSION) ON TRACK DIRECTLY OVER NO. 3 ROADWHEEL.
  - a. IF CANTEEN CUP OBSCURES LINE OF SIGHT, TRACK TENSION IS WITHIN ACCEPTABLE LIMITS.
  - b. IF TOP OF CANTEEN CUP IS ON OR BELOW LINE OF SIGHT, TRACK IS TOO LOOSE. INCREASE TRACK TENSION AS REQUIRED, AND REPEAT STEP 2 TO MAKE SURE TRACK IS NOT TOO TIGHT.

### INCREASING TRACK TENSION

PUMP GREASE INTO PRESSURE INPUT FITTING WITH GREASE GUN UNTIL TENSION IS ADJUSTED AS INDICATED IN STEPS 1 THROUGH 3.

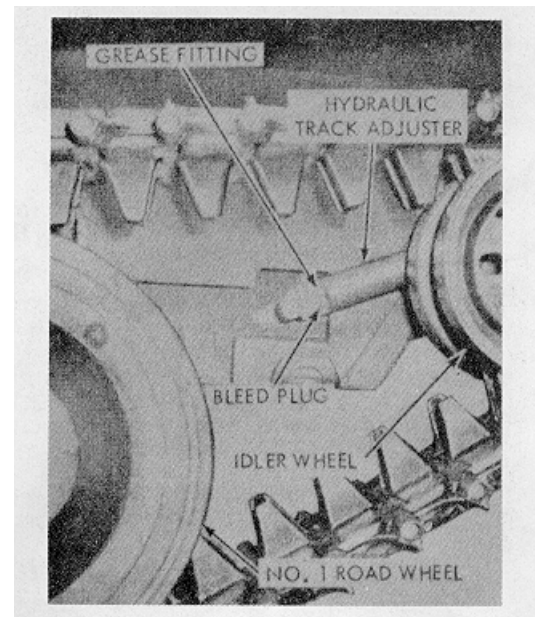

B. ADJUSTING TRACK TENSION

**NOTE:** IF TRACK SAG CANNOT BE TAKEN UP, DECREASE TRACK TENSION, REMOVE 1 TRACK SHOE (FIG. 5-5) AND READJUST TRACK TENSION.

### DECREASING TRACK TENSION

OPEN PRESSURE BLEED PLUG ON TRACK HYDRAULIC ADJUSTER AND REDUCE PRESSURE UNTIL TENSION IS ADJUSTED AS INDICATED IN STEP 3. TIGHTEN PLUG AND GREASE FITTING TO 12-16 POUND-FEET.

Figure 5-4. Checking and adjusting track tension

WE 12134

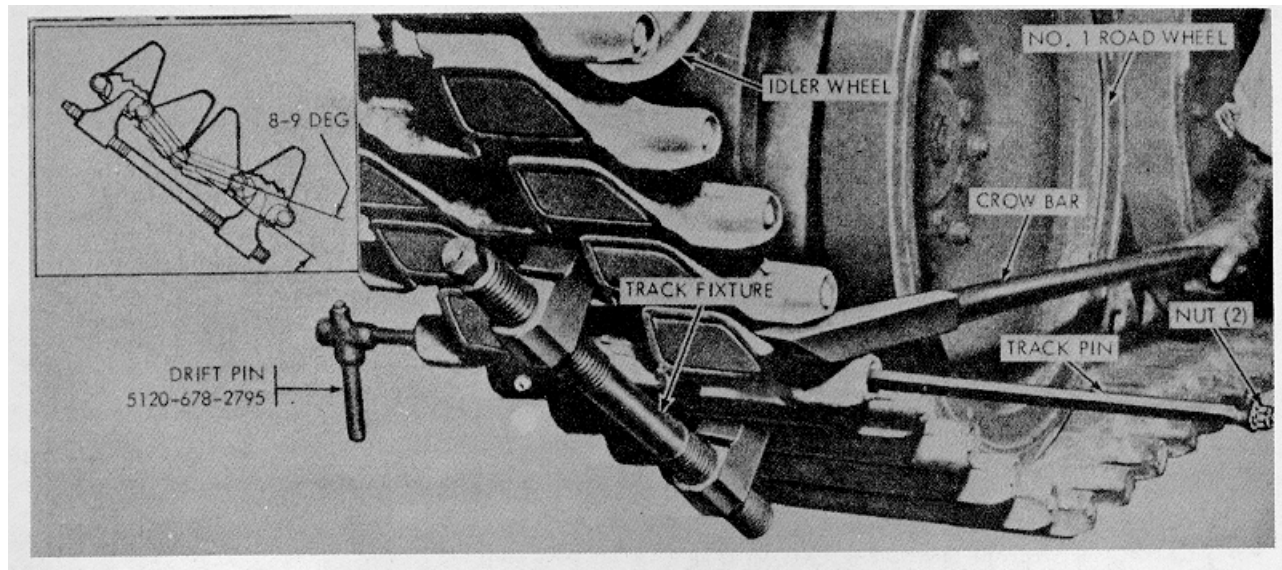

### REMOVAL

1. BRING VEHICLE TO A COASTING STOP ON LEVEL GROUND WITHOUT APPLYING BRAKE.
2. LOOSEN PRESSURE RELIEF VALVE ON TRACK ADJUSTER TO RELIEVE TRACK TENSION.
3. INSTALL TRACK FIXTURE BETWEEN IDLER WHEEL AND NO. 1 ROAD WHEEL AND TIGHTEN TO RELIEVE TENSION FROM TRACK PIN, USING WRENCH 5120- 288-9681 AND HANDLE 5120-449-7042.
4. REMOVE 1 TRACK PIN NUT AND CAREFULLY DRIVE TRACK PIN OUT, USING DRIFT PIN 5120-678-2795.
5. REMOVE TRACK FIXTURE AND DRIVE VEHICLE SLOWLY REARWARD UNTIL VEHICLE IS CLEAR OF TRACK.

### INSTALLATION

1. DRIVE VEHICLE FORWARD SLOWLY ONTO TRACK UNTIL REAR END OF TRACK ON GROUND MAY BE RAISED OVER AND ENGAGED WITH DRIVE SPROCKET.
2. CONTINUE DRIVING FORWARD GUIDING TRACK OVER ROAD WHEELS AND STOP WHEN END OF TRACK ON GROUND IS MIDWAY BETWEEN IDLER WHEEL AND NO. 1 ROAD WHEEL.

**NOTE.** SHUT OFF ENGINE AND LEAVE PARKING BRAKE OFF.

3. INSERT CROW BAR THROUGH TRACK AND PRY FORWARD OVER IDLER WHEEL TO PULL TRACK TAUT.
4. INSTALL TRACK FIXTURE AND TIGHTEN UNTIL TRACK PIN HOLES ARE ALIGNED, USING WRENCH 5120-288-9681 AND HANDLE 5120-449-7042.
5. DRIVE DRIFT PIN FROM BEHIND, THROUGH TRACK PIN HOLES UNTIL FLUSH WITH FRONT FACE OF SHOE.
6. DEPRESS CONNECTING SHOES 8 TO 9 DEGREES WITH CROW BAR TO PROPERLY ALIGN HEX IN SHOES AND DRIVE TRACK PIN IN PLACE (SEE INSERT ABOVE).
7. INSTALL 1 NUT AND TIGHTEN.
8. REMOVE TRACK FIXTURE AND ADJUST TRACK TENSION (FIG. 5-4).

**NOTE .** IF EXCESSIVE TRACK SAG CANNOT BE TAKEN UP WHEN ADJUSTING TRACK, REMOVE 1 TRACK SHOE AND READJUST TRACK TENSION.

9. USE PAINT TO MARK TRACK SHOES WHERE NUTS HAVE BEEN DISTURBED.
10. NOTIFY ORGANIZATIONAL MAINTENANCE TO TORQUE NUTS DISTURBED TO 120-130 POUND- FEET AS SOON AS POSSIBLE, AND AGAIN AFTER 50 MILES.

WE 12079 1

Figure 5-5. Removal/installation of track



A VEHICLE WITH TRACK BLOWN OFF, DAMAGED ROADWHEELS, OR WITH BROKEN IDLER WHEELS MAY BE SHORT-TRACKED ON ONE SIDE AND STILL BE ABLE TO MANEUVER AT RESTRICTED SPEED SO LONG AS 1 DRIVE SPROCKET AND ANY COMBINATION OF ROADWHEELS INDICATED IN STEP 1 . ARE INTACT

### SHORT-TRACKING PROCEDURE

- THE FOLLOWING ARE ROADWHEEL AND SPROCKET COMBINATIONS W/TRACK SHOE REQUIRED (O INDICATES REMOVED ROADWHEEL).
 

1-2-3-4-5-S (89R OR 91L)*	0-2-3-4-0-S (73R OR 75L)
0-2-3-4-5-S (74R OR 76L)	0-2-4-0-S (73R OR 75L)
0-0-3-0-5-S (59R OR 61 L)	0-2-0-0-5-S (73R OR 75L)
0-0-3-4-5-S (60R OR 62L)	1-0-0-5-S (88R OR 90L)
0-2-0-4-5-S (74R OR 76L)	1-0-0-4--S (88R OR 90L)
0-2-3-0-5-S (74R OR 76L)	1-0-0-4-5-S (47R OR 49L)

\* LEFT TRACK REQUIRES 2 MORE SHOES THAN RIGHT TRACK DUE TO OFFSET OF TORSION BARS.
- SELECT SECTION OF TRACK TO BE USED (STEP 1). IF TRACI IS DAMAGED, SELECT LEAST DAMAGED SHOES. REMOVE REMAINDER OF TRACK AND STOW ON VEHICLE.
- MANEUVER AND ALIGN THE SPECIFIED SHOE SECTION IN FRONT OF ROADWHEELS.
 

**NOTE.** IT MAY BE NECESSARY TO BREAK TRACK INTO SMALLER SECTIONS FOR HANDLING. RECONNECT THE SECTIONS.
- DRIVE VEHICLE SLOWLY FORWARD ONTO TRACK.
- AS SOON AS VEHICLE POSITION ON TRACK PERMITS, GUIDE REAR END OF TRACK OVER SPROCKET SO SPROCKET TEETH ENGAGE TRACK(USE TRACK PIN OR DRIFT PIN TO GUIDE TRACK).
- DRIVE VEHICLE SLOWLY FORWARD, GUIDING TOP OF TRACK TO +30-5: 00 O'CLOCK POSITION AT FRONT OF LEAD WHEEL (SEE ILLUSTRATION ABOVE).
- USING TRACK FIXTURE, PULL ENDS OF TRACK TOGETHER AND INSTALL TRACK PIN (FIG. 5-5).
 

**NOTE.** IN ORDER TO CONNECT TRACK, SOME SLACK MAY BE REMOVED BY BLOCKING BEHIND LEADING ROAD- WHEEL, BETWEEN WHEEL AND TRACK. STEER AWAY FROM SHORT-TRACKED SIDE, AND VERY CAREFULLY APPLY:POWER IN FORWARD GEAR TO TIGHTEN TRACK.
- TIE UP ANY REMAINING ROADWHEEL ARMS TO AVOID INTERFERENCE WITH OBSTACLES AND DAMAGE TO SPINDLES AND ARMS.

### OPERATION OF SHORT-TRACKED VEHICLE

- DO NOT EXCEED 10 MPH FORWARD, 4 MPH REVERSE, OR 2 MPH OVER EARTHEN MOUND OBSTACLE. PIVOT STEER AND OBSTACLE CROSSING IS NORMAL EXCEPT AS IN- DICATED IN EXAMPLES ILLUSTRATED IN FIGURE 5-5.2.
- AVOID PIVOT TURNS TOWARD SHORT-TRACKED SIDE WHENEVER POSSIBLE.
- GEARED STEER WILL REACT SLOWLY WHEN STEERING TOWARD FULL TRACKED SIDE, AND QUICKLY TOWARD SHORT-TRACKED SIDE.

Figure 5-5.1. Emergency short-tracking procedure. (1 of 2)

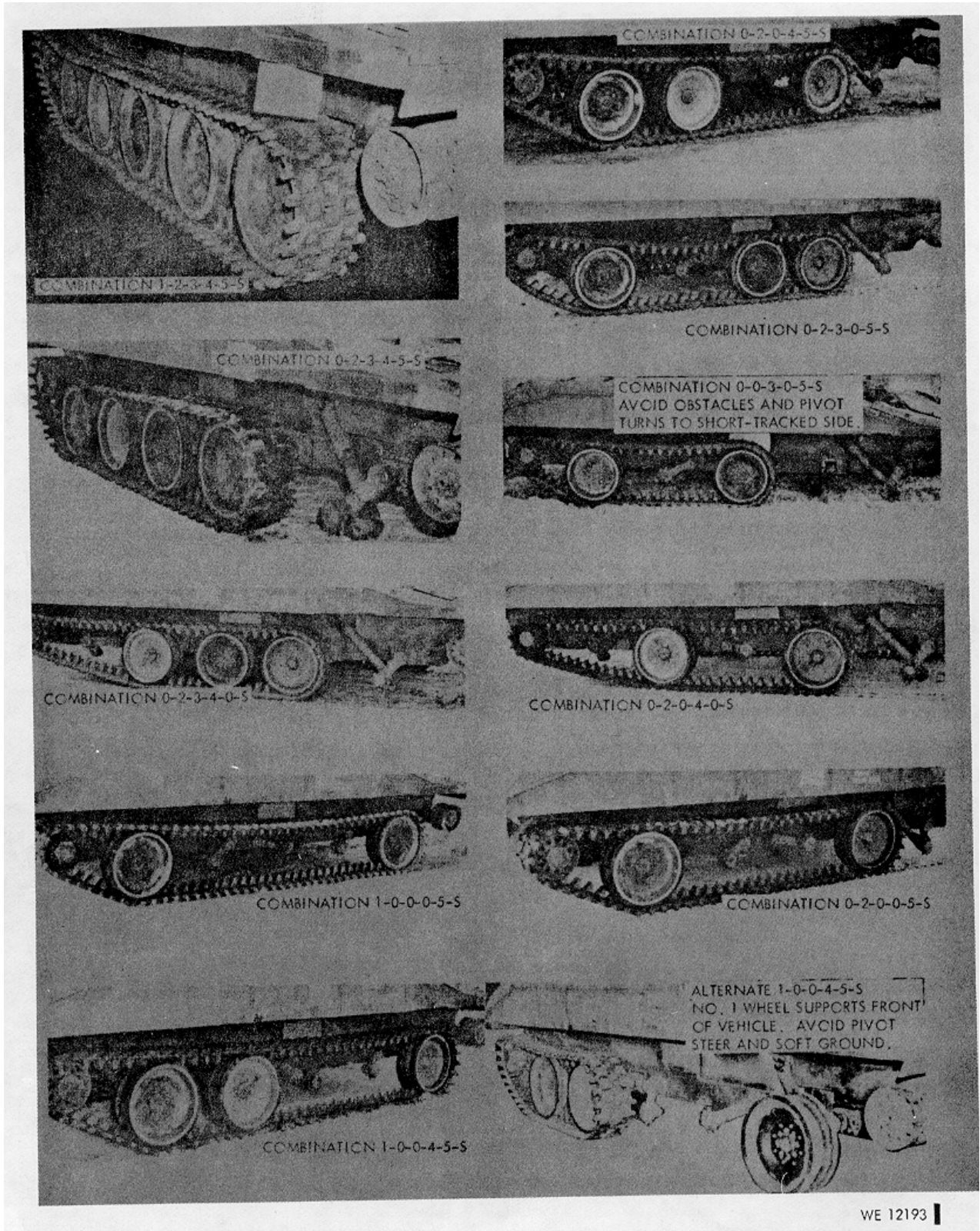

Figure 5-5.2. Emergency short-tracking procedure (2 of 2)



TABLE 5-3. SPARE LAMPS - HULL

WHERE USED-	FED.STOCK NO	FIG/ITEM
* Driver's Indicator Panel (MS 25237-327)	6240-155-7836	2-9
* Driver's Switch Panel (MS 25237-327)	6240-155-7836	2-10
Dome Light (Red Lens) (MS 15570-623)	6240-019-3093	5-6/A
Dome Light (White Lens) (MS 35478-1691)	6240-295-2668	5-6/A
* C-2296/VRC Intercom Set Control (8168874)	6240-155-7967	5-6/C
* C-2297/VRC Intercom Set Control (8168874)	6240-155-7967	2-6/E
* Personnel Heater Control Box (11621411)	6240-950-1678	2-17
Coolant Heater- Control Box (11621411)	6240-950-1678	2-17
Blackout Stoplight (MS 15570-1251)	6240-019-0877	5-6/D
Blackout Marker Light (4 places) (MS 15570-1251)	6240-019-0877	5-6/B, C, D
Service Taillight (MS 15570-1251)	6240-019-0877	5-6/C
Service Stoplight (MS 35478-1683)	6240-044-6914	5-6/C
Blackout Drive Light (MS 35478-1683)	6240-044-6914	5-6/B
* Turn lens counterclockwise and remove. Remove lamp from lens.		

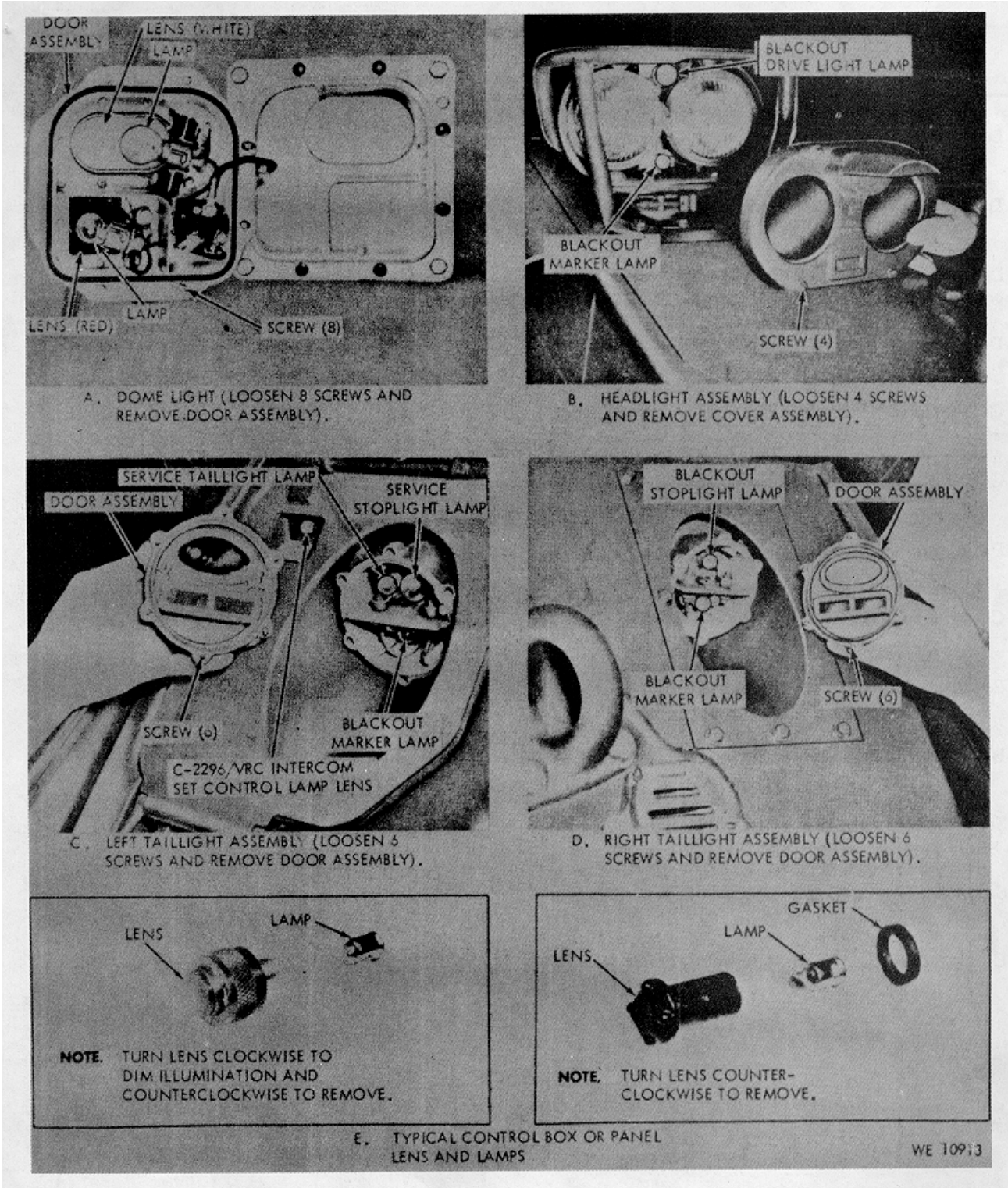

Figure 5-6. Replacement of lamps - hull

TABLE 5-4. DRAINING COOLANT AND FUEL SYSTEMS

STEP	PROCEDURE	FIG/ITEM
<b>DRAINING COOLANT SYSTEM (NORMAL TEMPERATURES TO -400F)</b>		
1	Traverse turret sideways and open engine left exhaust grille.	1-2/5
2	Remove surge tank filler cap. CAUTION: If vehicle was previously operated, open surge tank filter cap slowly to allow steam to escape.	5-2/A
3	Remove coolant drain plug hull access plug.	5-7/10
4	Remove coolant drain plug.	5-7/1
<b>NOTE.</b>		
1. <u>In temperate areas where the local ambient temperature is between +80° and +32°, use 50% water and 50% antifreeze. Refer to paragraph 1-6c for proper antifreeze to be used. If, and only if, the recommended antifreeze is not available, use rust inhibitor FSN 6850-753-4967 with clean soft water.</u>		
2. <u>When operating vehicle with expected temperatures between +32°F to -40°F, coolant system mixture is 50%water and 50%; antifreeze. Start engine immediately after refilling to mix water and antifreeze. Refer to paragraph 1-6c for proper antifreeze to be used.</u>		
3. <u>When operating in temperatures of +80°F or over, fill with 6 gallons of clear water. Dissolve 22-1/2 ounces of inhibitor (6850-753-4967) in 1 gallon of warm water and add to system while engine is idling. Add sufficient water to fill system to operating level. Record contents of coolant system on DD Form 1397 tag.</u>		
<b>DRAINING COOLANT SYSTEM (-40°F. TO -650F TEMPERATURE)</b>		
1	Open engine left and right exhaust grilles.	1-2/5
2	Follow steps 2 through 4 above.	
<b>NOTE.</b> <u>Allow system to drain, then proceed to following steps.</u>		
3	Remove engine oil filter hull access plug and open drain cock on bottom of oil cooler.	5-7/9, 10
4	Reach down over engine and open engine block left and right drain cocks.	5-7/8
5	Open thermostat housing drain cock.	5-7/7
<b>NOTE.</b> <u>When operating vehicle with expected temperatures between -40°F. to -65°F., use full strength antifreeze; refer to paragraph i-6c.</u>		
<b>DRAINING FUEL SYSTEM</b>		
1	Open 2 fuel tank valves.	5-3/A
2	Remove fuel tank drain hull access plug.	5-7/10
3	Remove fuel tank outlet hose drain plug, and drain fuel into suitable container.	5-7/4

**LEGEND**

1. COOLANT DRAIN PLUG
2. ENGINE OIL DRAIN PLUG
3. ENGINE OIL FILTER AND ENGINE DRAIN COLLECTOR BOX DRAIN PLUGS.
4. FUEL TANK OUTLET HOSE DRAIN PLUG
5. TRANSMISSION DRAIN PLUG
6. ENGINE MOUNT SCREW (2)
7. THERMOSTAT HOUSING DRAIN COCK
8. ENGINE BLOCK DRAIN COCK (1 ON EACH SIDE OF ENGINE)
9. OIL COOLER DRAIN COCK

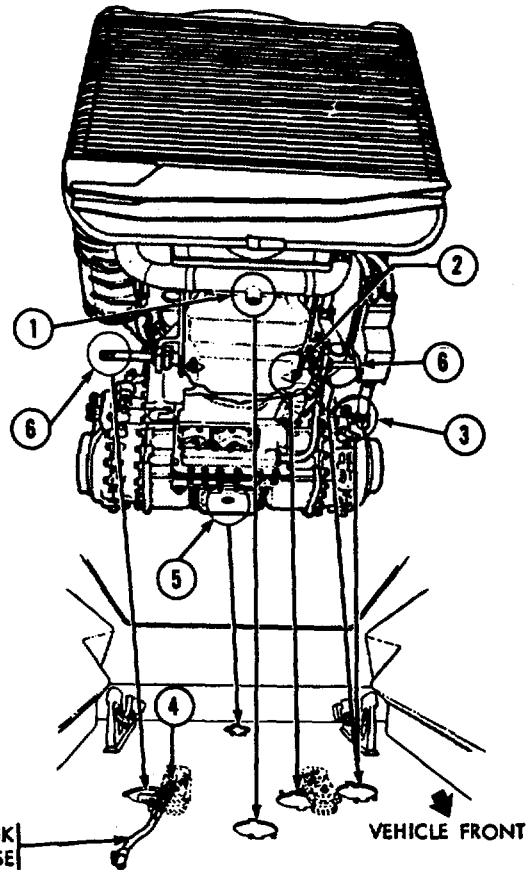
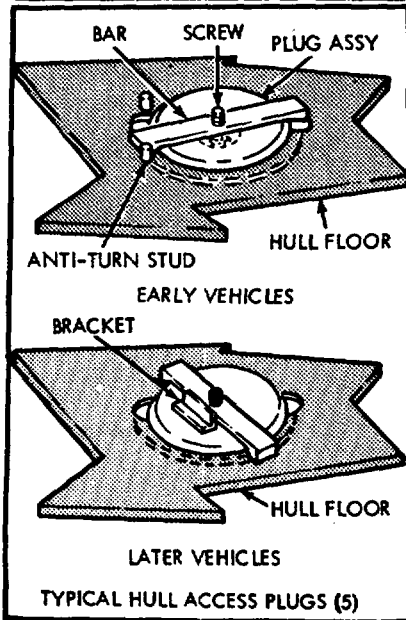
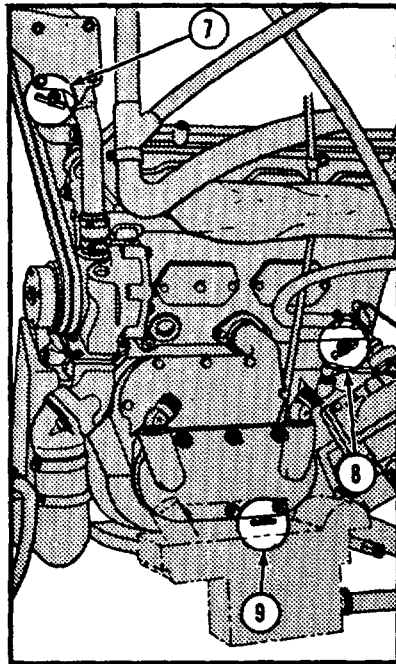

**HULL ACCESS PLUG REMOVAL**

USE 9/16 INCH SOCKET TO TURN SCREW COUNTERCLOCKWISE TO LOOSEN BAR (TAP SCREW HEAD LIGHTLY IF REQUIRED TO LOOSEN BAR FROM HULL FLOOR).

EARLY VEHICLES - BAR WILL TURN WITH SCREW AND DROP THROUGH SLOTS OF ACCESS HOLE.

LATER VEHICLES - ROTATE ACCESS PLUG TO ALIGN BAR WITH SLOTS.

**HULL ACCESS PLUG INSTALLATION**

**CAUTION: ACCESS PLUGS MUST SEAL TIGHTLY TO PREVENT LEAKAGE DURING WATER OPERATION. NOTIFY ORGANIZATIONAL MAINTENANCE TO REPLACE WORN OR DAMAGED PACKING.**

LOOSEN SCREW UNTIL FLUSH WITH TOP OF BAR AND INSERT PLUG IN ACCESS HOLE.

EARLY VEHICLES - TURN SCREW CLOCKWISE UNTIL BAR IS AGAINST BUT NOT ON ANTI-TURN STUD. TIGHTEN SCREW TO 33-37 POUNDS- FEET. IF REPLACEMENT SCREW IS REQUIRED USE ONLY MS90727-63 (5305-269-3239).

LATER VEHICLES - PUSH PLUG INTO PLACE AND TURN PLUG APPROXIMATELY 90°. HOLD PLUG IN POSITION WHILE TIGHTENING SCREW TO 33-37 POUNDS- FEET.

WE 12023

Figure 5-7. Hull access plugs, power plant and fuel tank drain plugs

**Section 5-4. MAINTENANCE OF TURRET, CUPOLA, SIGHTING AND FIRE CONTROL, AND MISSILE SUBSYSTEM UNITS**

**5-4. Crew Maintenance Instructions**

The following tables and illustrations provide maintenance instructions to be performed by the crew.

*TABLE 5-5. CREW MAINTENANCE - TURRET, CUPOLA, SIGHTING AND FIRE CONTROL, AND MISSILE SUBSYSTEM*

ITEM	INSPECT	TEST	SERVICE	ALIGN	REPLACE
Azimuth Indicator	Table 4-1 and Fig. 2-27		Table 5-7		
M13A1C Elevation Quadrant	Table 4-1 and Fig. 2-28		Table 5-7		
Missile Subsystem Units Lamps	Table 4-1	Table 2-12	Table 5-7	Table 2-12	Table 5-6
XM44 Series Periscope Fig. 2-26	Table 4-1 and Fig. 5-8		Table 5-7 and B, Fig. 5-8		A, Fig. 5-8
M47 Periscope	Table 4-1 and Fig. 5-8		Table 5-7		A, Fig. 5-8
M48 Periscope	Table 4-1 and Fig. 5-8		Table 5-7		A, Fig. 5-8
M1A1 Quadrant	Fig. 2-28		Table 5-7		
M119 or M127 Telescope	Table 4-1 and Fig. 2-25		Table 5-7		

*TABLE 5-6. SPARE LAMPS - TURRET*

WHERE USED	FED.STOCK NO.	FIG/ITEM
** Azimuth Indicator (MS 25236-8623)	6240-155-7864	2-27
* Cupola Control Assembly (MS 25237-327)	6240-155-7836	2-21
Dome Light (Red Lens) (MS 15570-623)	6240-019-3093	5-6/A
Dome Light (White Lens) (MS 35478-1691)	6240-295-2668	5-6/A
* Grenade Launcher Control Panel (MS 25237-327)	6240-155-7836	3-15
* Gun and Turret Control Selector (MS 25237-327)	6240-155-7836	2-19
* Loader's Control Box (MS 25237-327)	6240-155-7836	3-1/A

TABLE 5-6. SPARE LAMPS - TURRET - Continued

WHERE USED	FED.STOCK NO.	FIG/ITEM
Night Vision Sight PVS2 (for Cal 50 Machine Gun) (MS35478-87) Removal: Place rotary control switch in OFF position, unscrew reticle lamp cap, and remove lamp.	6240-196-4519	2-29
* Radio Equipment (Call) (MS 25237-327)	6240-155-7836	7-4
Radio Equipment (Channel Dial) (MS 25237-327)  Removal: Turn lamp access cover counterclockwise and remove. Remove lamp.	6240-155-7836	7-4
* Missile Subsystem Test Checkout Panel (MS 25237-327)	6240-155-7836	2-30
* XM44 Series Periscope Control Panel (MS25237-327)	6240-155-7836	2-26/6
XM44 Series Periscope Reticle (MS25231-316)  Removal: Unscrew receptacle assembly and remove lamp.	6240-817-9803	2-26/25
* M119 or M127 Telescope Missile Reticle (8624583)  Removal: Press in and rotate reticle lamp housing counterclockwise and remove. Press in and rotate reticle lamp and remove.	6240-921-4493	2-25/8
M119 or M127 Telescope Conventional' Reticle (86Z4583)  Removal: Release latch and open cover. Press and rotate reticle lamp counterclockwise and remove.	6240-921-4493	2-25/5
* M119 or M127 Telescope Reticle Dimmer Box (MS25237- 327)  <b>CAUTION: Be sure lamp of correct voltage rating is used when replacing.</b>	6240-155-7836	2-25
<p>* Turn lens or jewel counterclockwise and remove. Remove lamp.</p> <p>** Turn lamp counterclockwise and remove.</p>		

TABLE 5-7. CLEANING AND INSPECTION - SIGHTING AND FIRE CONTROL AND MISSILE SUBSYSTEM UNITS

COMPONENT	INSPECTION AND CLEANING
<p><b>SIGHTING AND FIRE CONTROL EQUIPMENT:</b></p> <p>Metal Parts</p> <p>Rubber Parts</p> <p>Optical Surfaces</p>	<p style="text-align: center;"><b>INSPECTION</b></p> <p><b>NOTE.</b> <u>Check that all components are free from grease, dirt, foreign matter, rust, corrosion, and excessive wear.</u></p> <p style="text-align: center;"><b>CLEANING</b></p> <p>Use dry-cleaning solvent or mineral spirits to remove grease, oil, and dry thoroughly. Avoid rubber parts. Apply a light grade of lubricating oil to polished surfaces.</p> <p>Use soap and warm water. Apply coating of powdered technical talcum to preserve.</p> <p>Brush lightly with artists's clean camel hair brush. To remove oil or grease below +320°F, moisten lens tissue paper with alcohol and clean.</p> <p><b>CAUTION:</b> <u>Do not use polishing liquids, pastes, abrasives, or cleaning cloths for cleaning lenses.</u></p>
<p><b>MISSILE SUBSYSTEM UNITS:</b></p> <p>Metal Parts</p> <p>Optical, Surfaces</p> <p>Transmitter Door</p>	<p style="text-align: center;"><b>INSPECTION</b></p> <p><b>NOTE.</b> <u>Check that all components are free from grease, dirt, foreign matter, rust, corrosion, and excessive wear.</u></p> <p style="text-align: center;"><b>CLEANING</b></p> <p>Wipe equipment with a clean cloth to remove dust, dirt, or grease at regular intervals and especially after operating in muddy, sandy, or dusty terrain.</p> <p>Refer to cleaning optical surfaces above.</p> <p>Lubricate hinge and actuating rod (LO 9-2350-230-12).</p>

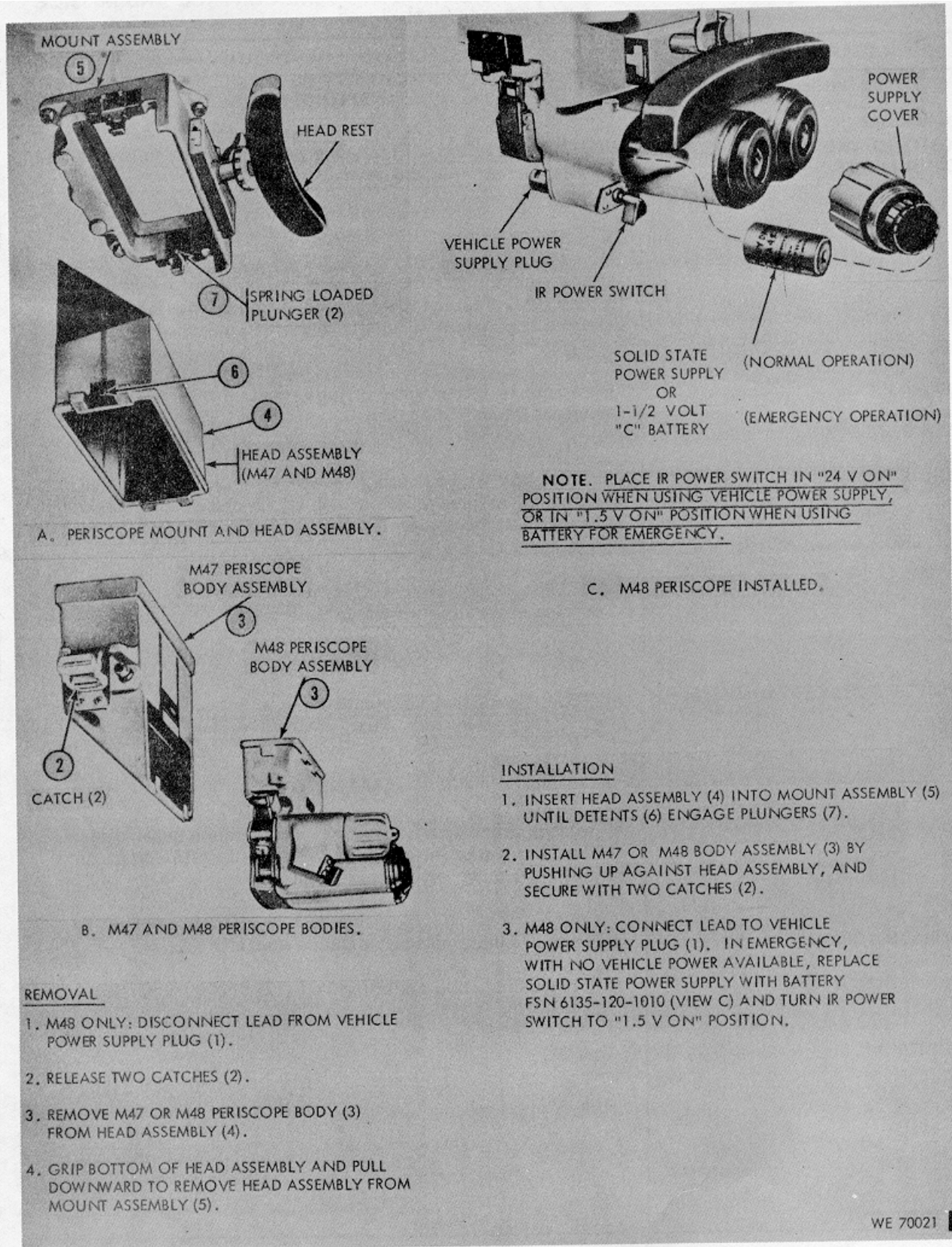

Figure 5-8. Removal/installation - M47 and M48 periscopes.  
 Figure 5-8.1 - deleted.



**Section 5-5. MAINTENANCE OF ARMAMENT**

**5-5. Crew Maintenance Instructions**

**a. General.** The following tables and illustrations provide maintenance instructions to be performed by the crew.

**b. Inspection.** During maintenance of the components listed in table 5-8, inspect all parts for damage and proper functioning.

TABLE 5-8. CREW MAINTENANCE - ARMAMENT

ITEM	SERVICE	ADJUST	REPLACE
<b>CAUTION:</b> Avoid damage to air cylinders, which are under very high pressure.			
152MM Gun-Launcher and Mount: Breech Actuating Mechanism Group Bore and Breech Chamber Obturator Seal  Evacuator Cylinder Cleaning and Lubrication Recoil Mechanism Counterrecoil Buffer Assembly 7.62MM Machine Gun Mount Recoil Mechanism Reservoir	Fig. 3-1 Fig. 3-1 Fig. 5-10. 1, 10. 2 and Table 5-8. 1  Table 5-8.1 Table 5-8.1 Fig. 5-9 Fig. 2-24 Fig. 3-2	Fig. 5-10  Fig. 3-2	
7.62MM Machine Gun and Flash Hider Cal..50 Machine Gun	LO 9-2350-230-12 and Figs. 5-11 through 5-13 LO 9-2350-230-12 and Figs. 5-14, 15, 16 17		Fig. 3-7  Fig. 3-14

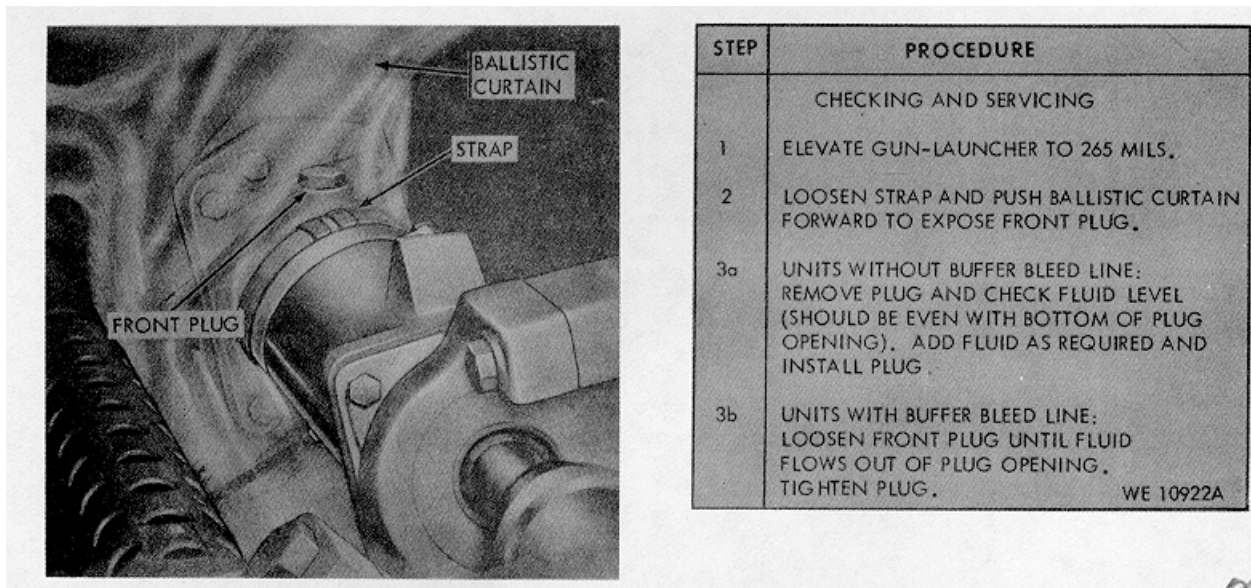

Figure 5-9. Checking and servicing counterrecoil buffer

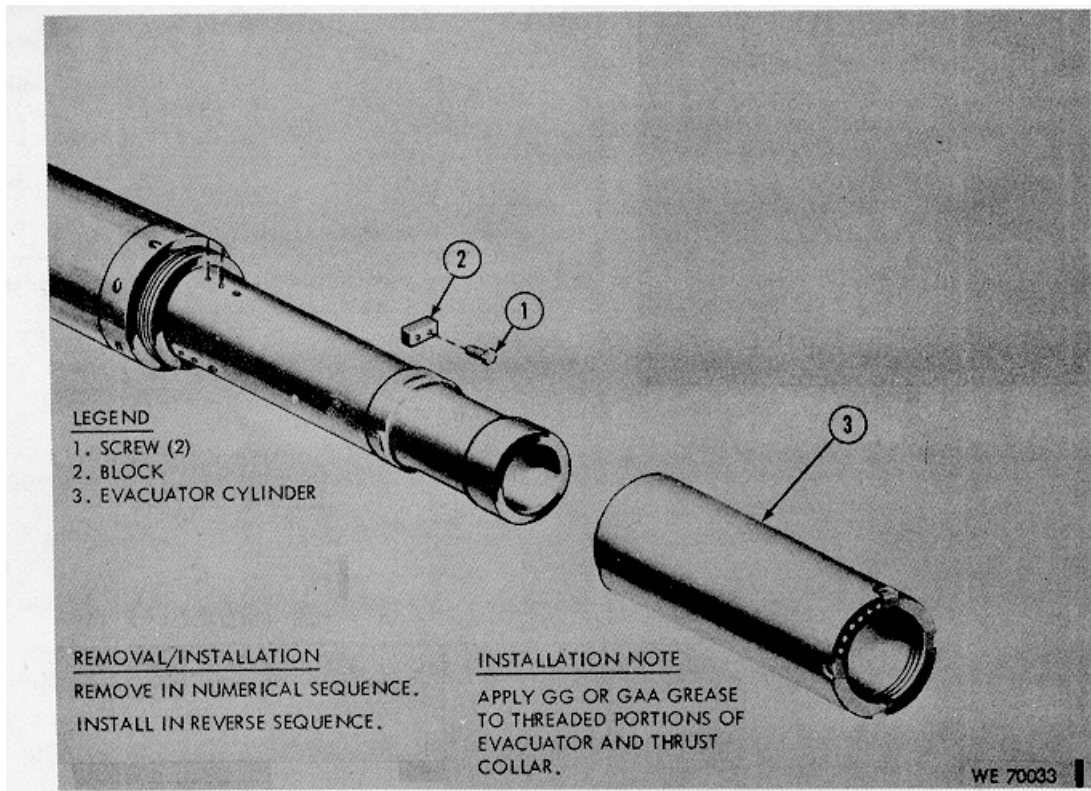

Figure 5-10. Removal/installation - evacuator cylinder

TABLE 5-8.1. CLEANING AND LUBRICATION OF GUN LAUNCHER (REFER TO FIG. 5-10.2)

DAILY CLEANING AND LUBRICATION (AT COMPLETION OF DAYS FIRING SCHEDULE)

1. Open breech and remove obturator seal (Fig. 5-10.1).
  2. Using a soft rag, wipe residue, dirt, and foreign material from obturator seal, rear face of gun tube, seal cavity, breech chamber front face, coupling and breech chamber buttress threads, and all exposed surfaces. **DO NOT USE STEEL WOOL.**
  3. Visually inspect all areas for cleanliness and reinstall obturator seal.
  4. Apply coating of lubricating oil(PL-S) to all cleaned areas. Spread evenly with a clean saturated rag or brush. Blow out detent cavity with dry compressed air. Make sure that coupling and breech chamber buttress threads are well lubricated.
  5. Hand crank breech chamber open and closed several times to check for smooth and normal operation. Leave breech backed out but not rolled over to permit air circulation and reduce condensation. Return hand crank to an approximate 12:00 o'clock lockout position.
  6. Before firing, wipe dry all areas except coupling and breech chamber buttress threads. Maintain lubricant on these threads at all times.
  7. Clean gun/launcher tube with RBC (M81 tube - also clean evacuator valves and chamber, Fig. 5-10).
  8. Notify organizational maintenance to service detent as necessary after days firing but not to exceed 40 rounds. Additional checking and cleaning is recommended if a prolonged period between firing missions exists.
- NOTE.** After firing 200 rounds, notify organizational maintenance to remove firing probe and inspect probe and breech chamber for erosion (Table 5-1).
9. (M81E1 and M81 Modified) Notify organizational maintenance to service check valve at least every 100 rounds. More frequent cleaning is recommended if carbon buildup or decrease in CBS air volume is suspected,

CLEANING AND LUBRICATION AT COMPLETION OF FIRING MISSION AND WHEN WEAPON WILL NOT BE USED FOR EXTENDED PERIODS

1. Immediately after firing and on next two following days thereafter, open breech, remove obturator seal, and thoroughly clean bore and breech chamber with RBC, (MIL-C-372) insuring that all powder-contacting surfaces (including rifling) are well coated. Do not wipe dry.
2. On third day after firing, clean bore with RBC, using RBC and a non-scratch pad or stiff bristle brush, wash obturator seal, breech chamber, front face and exposed surfaces, gun tube rear surface and seal cavity, and coupling threaded area. **DO NOT USE STEEL WOOL..**

(M81 only) On third day after firing or monthly if cannon is not being fired, remove evacuator and valves (Fig. 5-10). Clean all powder contacting surfaces with RBC. Wipe dry and apply a thin coating of PL-S. Apply GG at temperatures above 0°F and GAA below 0°F to threaded portions of evacuator and thrust collar before assembling.

TABLE 5-8.1. CLEANING AND LUBRICATION OF GUN LAUNCHER - CONT'D.

3. Wipe dry with clean, lint-free cloth and blow out detent cavity with dry compressed air.
 

**NOTE.** On vehicles equipped with closed breech scavenger system, close breech and activate scavenge system manually to clear check valve discharge port in tube.
4. Visually inspect for complete removal of residue, rust, and foreign matter.
5. Coat all cleaned surfaces with lubricating oil PL-S. Spread oil with a clean saturated cloth or brush. Leave breech backed out but not rolled over to permit air circulation and reduce condensation.
 

**NOTE.** If cannon will not be fired for one month or longer, use grease, aircraft and instrument GIA (MIL-G-23827).
6. Monthly thereafter, when cannon is not being fired, clean with RBC, wipe dry and relubricate as indicated in Step 5.
- 6A. In geographical areas where temperature variations create excessive moisture by condensation, crew maintenance should include WEEKLY removal of gun launcher dust shield, drying of all affected components and assuring that exposed portion of recoil mechanism sleeve is free of corrosion or rust. External surface of exposed sleeve may be thinly coated with Silicone Compound MIL-S-8660.
7. Wipe dry before firing all areas except breech chamber and coupling buttress threads. Maintain lubricant on these threads at all times.
8. Notify organizational maintenance to service check valve and/or detent (table 8-17. 1).

TABLE 5-9. DISASSEMBLY/ASSEMBLY - 7.62MM MACHINE GUN

DISASSY STEP	ASSY STEP	PROCEDURE	FIG/ITEM
1	13	Removal/installation of machine gun from vehicle.	Fig. 3-7
		<p><b>WARNING:</b> <u>Ammunition belt must be removed from the machine gun and chamber cleared.</u></p> <p><b>NOTE.</b> <u>White arrows in figures 5-11 through 5-12 indicate disassembly sequence, black arrows, assembly sequence.</u></p> <p>Barrel extension assembly is in rear position (charged), place trigger safety in the fire "F" position. Pull charger handle rearward and, while keeping tension on handle, depress manual firing trigger, allowing barrel extension to go forward slowly. Charge the machine gun, then place safety in safe "S" position. Depress the manual firing trigger. If the barrel extension assembly is released, notify organizational maintenance personnel.</p> <p><u>Functional Check</u> - Check the functioning several times by pulling charger to rear, and while maintaining tension on handle, depress the manual firing trigger. Barrel extension must release with safety in fire "F" position.</p>	Fig. 5-11

TABLE 5-9. DISASSEMBLY/ASSEMBLY - 7.62MM MACHINE GUN - Continued

DISASSY STEP	ASSY STEP	PROCEDURE	FIG/ITEM
		<b>NOTE.</b> <u>Use dummy cartridges to check functioning of machine gun.</u>	
2	12	Pull right side disconnecter pull ring rearward, rotate jacket assembly with bearing group counterclockwise until mounting block is free of receiver assembly. Push jacket assembly with bearing group forward and remove from receiver assembly.	Fig. 5-11.1
		<b>NOTE.</b> <u>When installing, position jacket assembly mounting block, hold on one disconnecter pull ring, pull out on opposite disconnecter pull ring, rotate the group into position, release ring.</u>	
3	11	To remove, pull barrel assembly from jacket assembly with bearing group. When installing, position barrel assembly into rear of jacket assembly with bearing until slot in barrel is aligned with barrel locator. Push barrel forward until stopped by locator.	Fig. 5-11.1
		<b>WARNING:</b> <u>Turn barrel assembly to make certain barrel locator enters barrel slot.</u>	
4-5	9-10	Remove cover assembly from receiver assembly. When installing position cover assembly on cover latch rod assemblies, then press down on cover until it locks in position.	Fig. 5-11.2
		<b>NOTE.</b> <u>Cover latch rod assemblies in locked (forward) position. Locks are released automatically by cover assembly when installed.</u>	
6	8	Lift up and remove feed tray group. When installing position feed tray group with cartridge stop on the right of the receiver.	Fig. 5-11.2
		<b>NOTE.</b> <u>Feed tray group may be removed or installed with cover assembly.</u>	
		<b>WARNING:</b> <u>Make certain that the barrel extension assembly is in forward position to prevent injury to personnel.</u>	
7	7	Push guide rod assemblies forward, rotate 1/4 turn counterclockwise to unlock, then remove rod assemblies and compression helical springs from holes in back plate assembly with solenoid. To install, position springs on guide rods, insert in holes in back plate, and into holes in rear of barrel extension, compress and rotate clockwise until secure.	Fig. 5-11.2
8	6	Slide back plate assembly with solenoid upward and remove from receiver assembly. To install, aline grooves on back plate with flanges on receiver assembly and push downward.	Fig. 5-11.2

TABLE 5-9. DISASSEMBLY/ASSEMBLY - 7.62MM MACHINE GUN - Continued

DISASSY STEP	ASSY STEP	PROCEDURE	FIG/ITEM
9	5	<p><b>CAUTION:</b> <u>Slamming of the back plate during installation will lower the receiver tabs and create a "runaway" gun.</u></p> <p>Pull rearward on charger handle of charger assembly until barrel extension group is fully retracted.</p> <p><b>WARNING:</b> <u>Use the hand charger assembly handle to retract barrel extension assembly. Never use the hands.</u></p> <p><b>NOTE.</b> <u>Depress right- or left-hand buffer support lever to release and/or install the barrel extension group.</u></p>	Fig. 5-11.2
10	4	<p>Grasp top portion of barrel extension assembly, depress buffer support lever, then pull rearward and slide barrel extension group from receiver assembly. To assemble, align barrel extension assembly camway with barrel extension rail on receiver, depress buffer support lever, then push barrel extension fully forward.</p>	Fig. 5-11.2
11	3	<p>Slide top portion of breechblock assembly left to center of barrel extension channel in barrel extension assembly, then lift straight up to remove. To install, position top portion of breechblock assembly in center of barrel extension channel, lower to align with breechblock camways, then slide breechblock to right.</p> <p><b>NOTE.</b> <u>Right top edge of breechblock assembly must align (flush) with right top edge of barrel extension assembly when installing in the machine gun.</u></p>	Fig. 5-12
12	2	<p>Remove retaining ring from charger mounting stud on receiver assembly that secures the charger assembly to receiver assembly.</p>	Fig. 5-12
13	1	<p>Pull hand charger off charger mounting stud and disengage front end of charger from buffer pivot pin on receiver assembly. To install, position the forward end of charger on pivot pin, slide in position on charger mounting stud, then secure charger to stud with retaining ring.</p>	Fig. 5-12

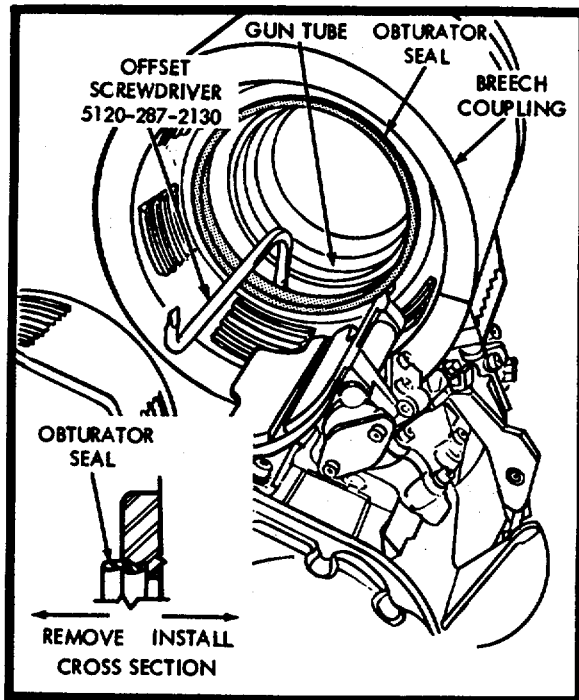

REMOVAL

INSERT SCREWDRIVER 5120-287-2130 BETWEEN GUN TUBE AND OBTURATOR GAS SEAL AND PULL TO SNAP SEAL OUT OF SEAT IN GUN TUBE.

CLEANING

REFER TO TABLE 5-8.1.

INSTALLATION

POSITION SEAL IN GUN TUBE AND SNAP INTO PLACE IN SEAT IN GUN TUBE.

**CAUTION:** USE PROPER TOOL AND EXTREME CARE DURING REMOVAL AND INSTALLATION TO AVOID DAMAGE TO THE SEAL.

WE 12162

Figure 5-10.1. Removal/installation - obturator seal

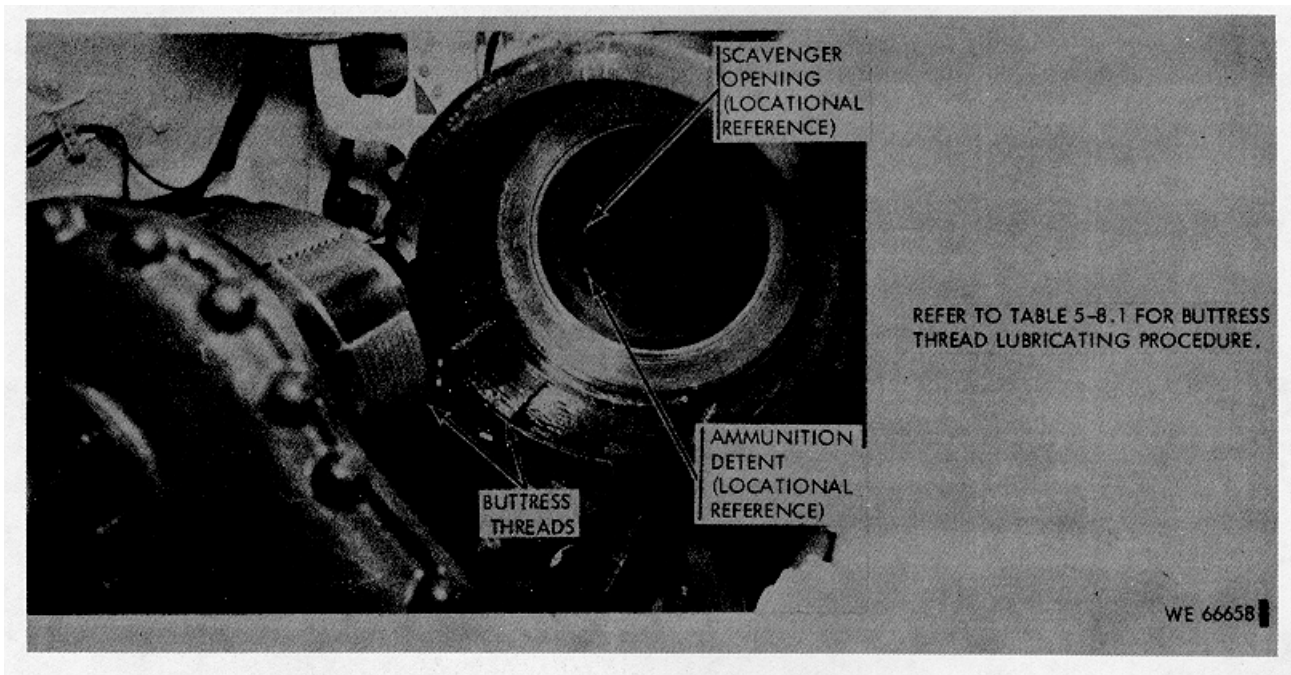

Figure 5-10.2. Gun-launcher buttress threads, and ammunition detent and scavenger openings

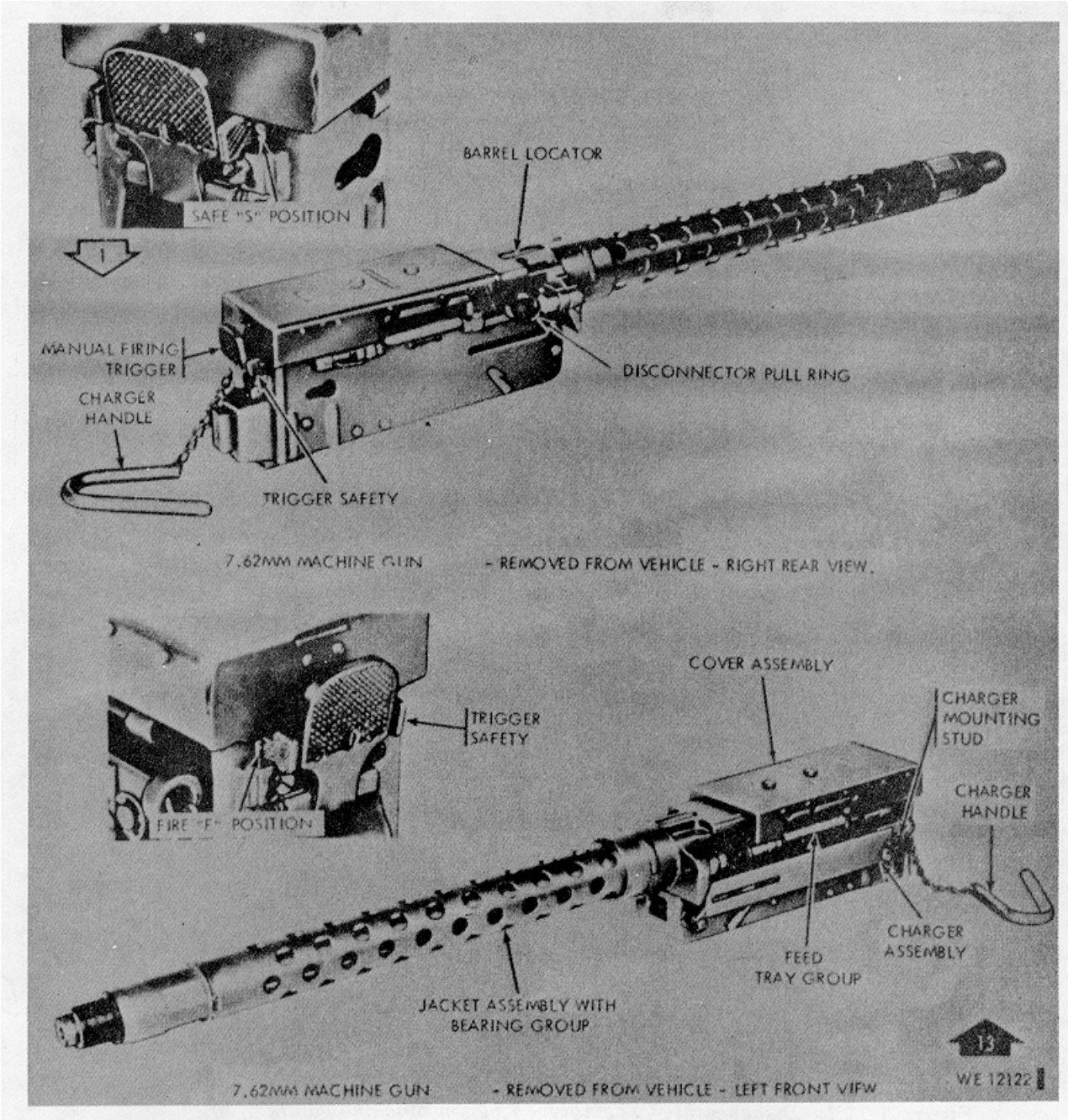

Figure 5-11. Disassembly/assembly - 7.62 mm machine gun (1 of 4)



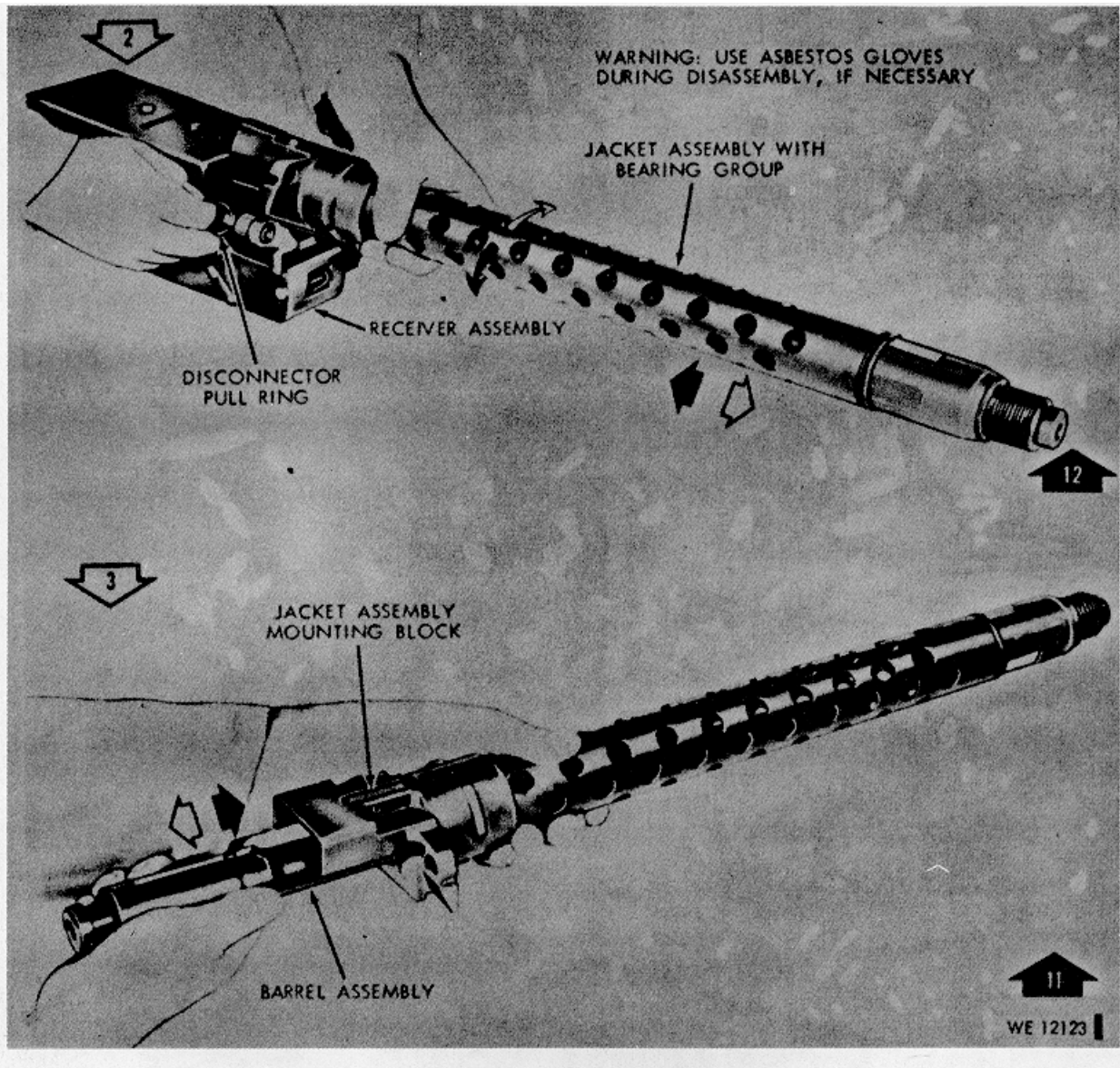

Figure 5-11.1. Disassembly/assembly - 7.62mm machine gun (2 of 4).

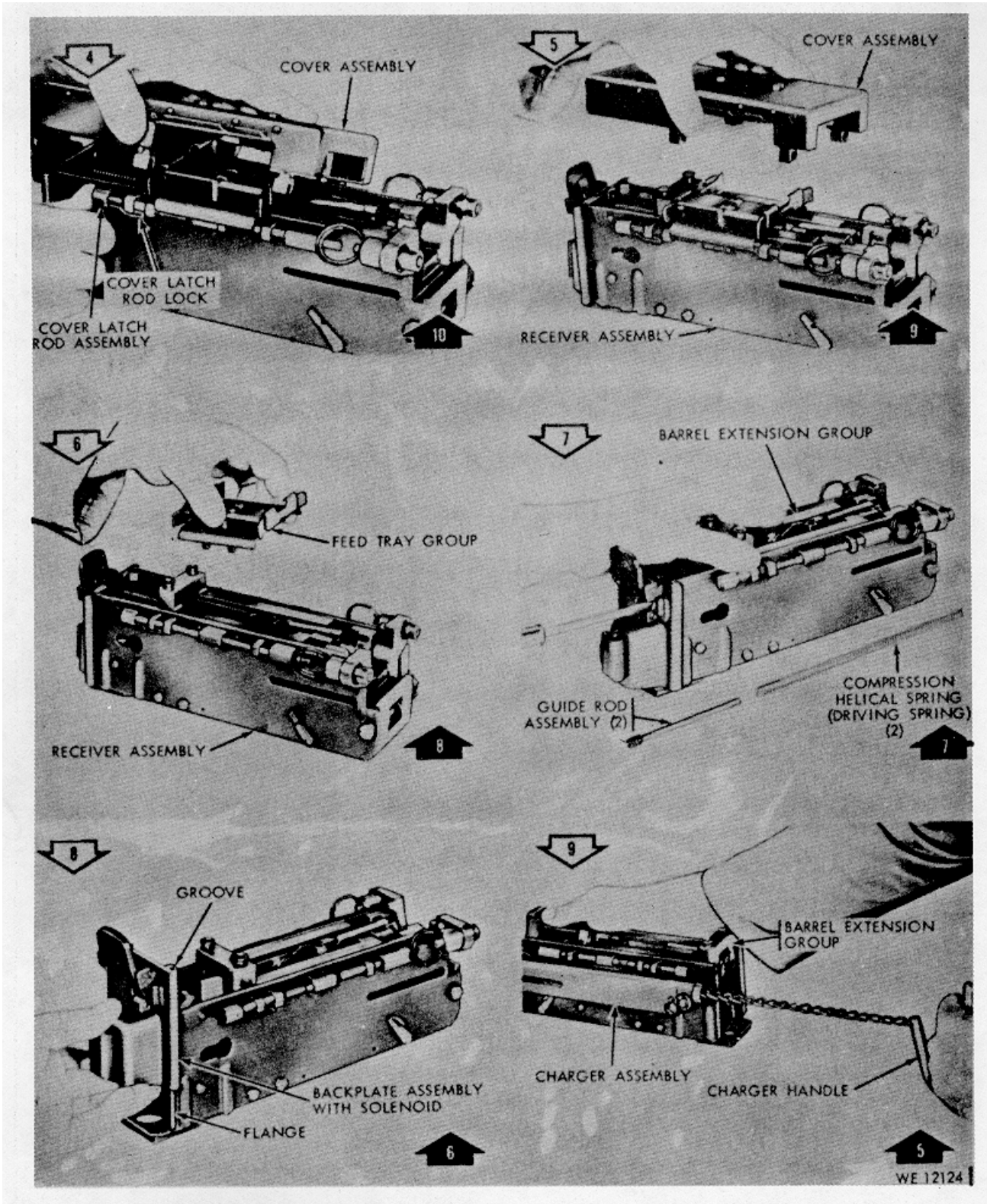

Figure 5-11.2. Disassembly/assembly - 7.62mm machine gun (3 of 4).

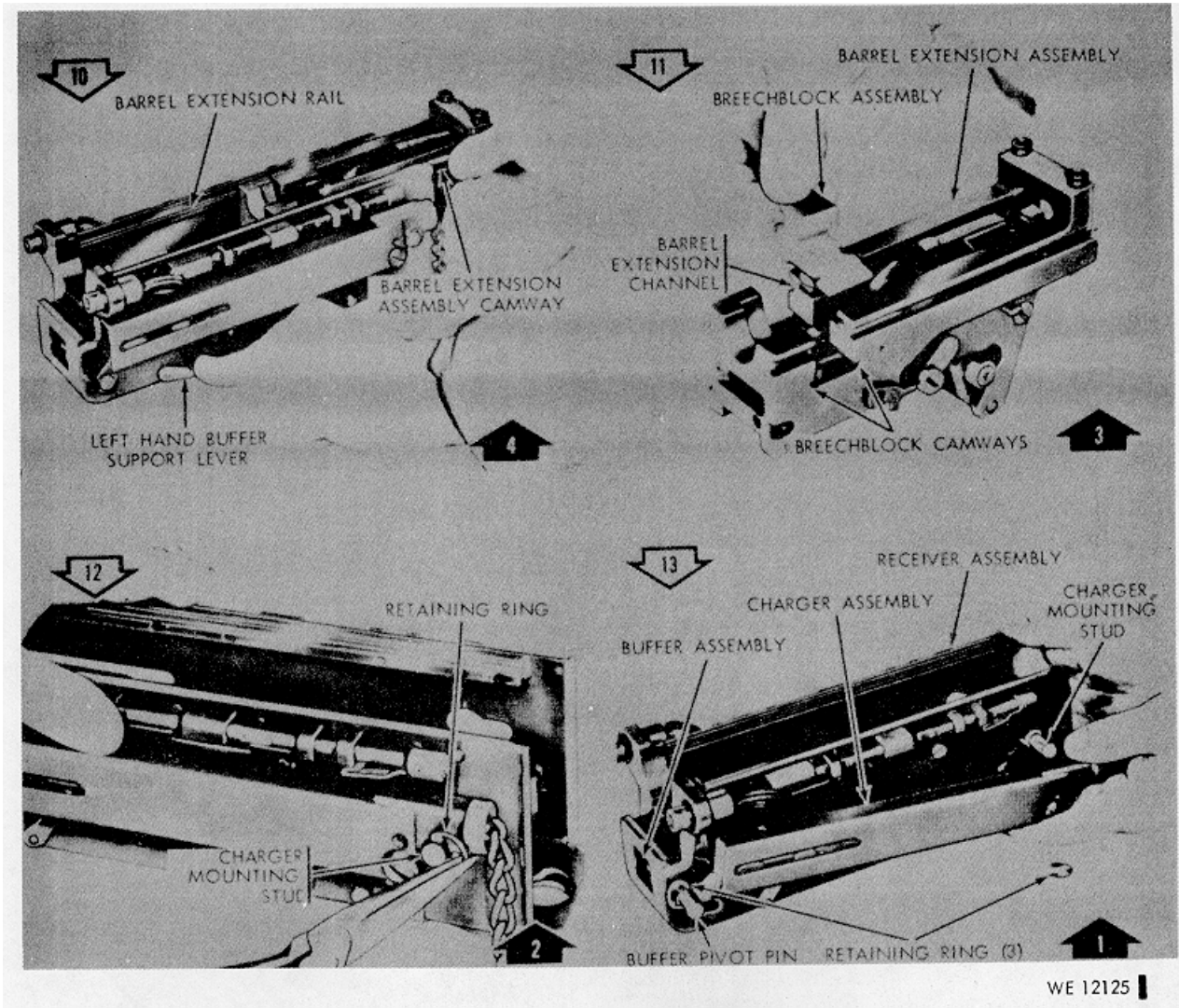

Figure 5-12. Disassembly/assembly - 7.62 mm machine gun (4 of 4)

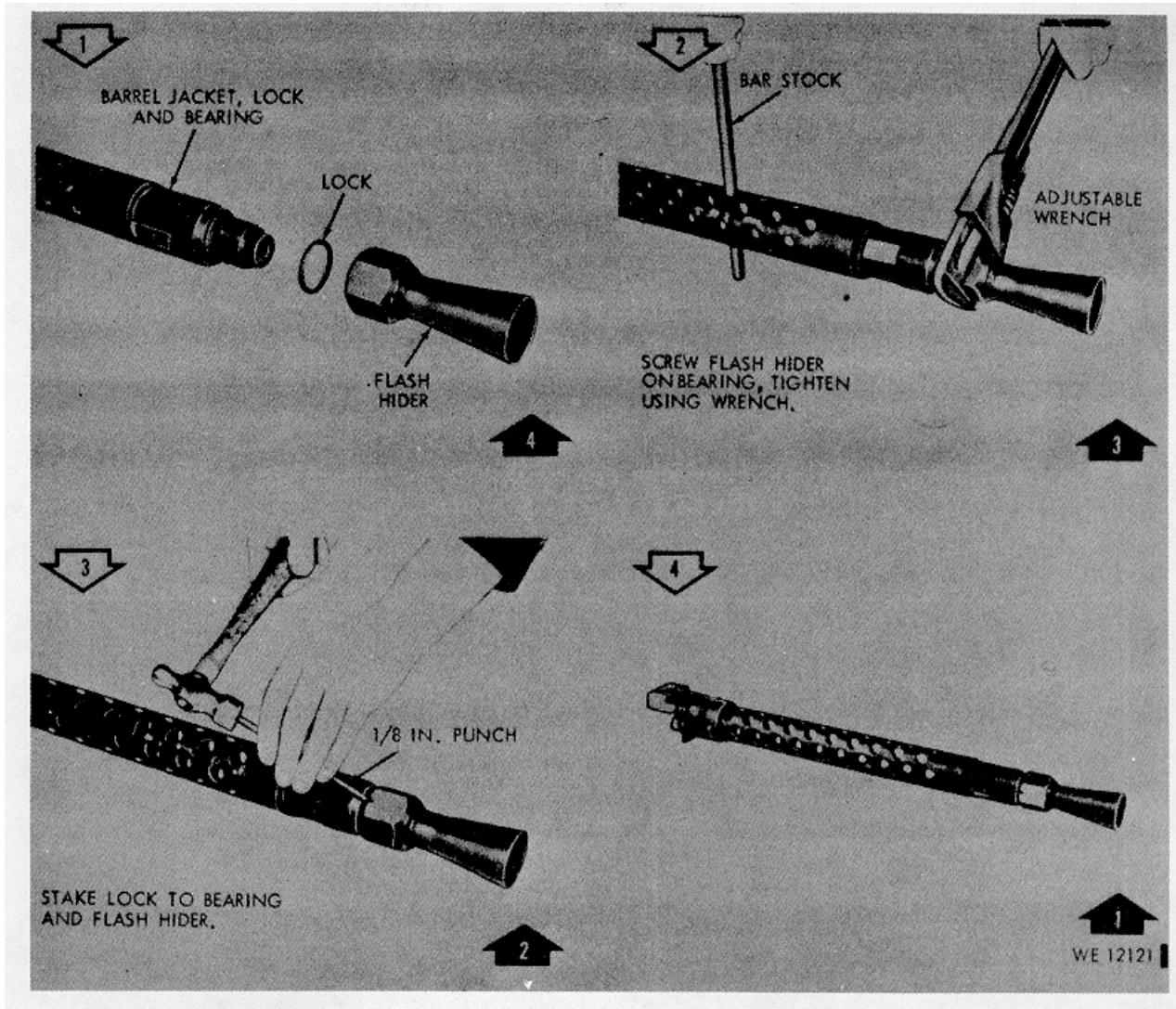

Figure 5-13. Removal/installation - 7.62 mm machine gun flash hider

5-27  
(5-28 Blank)

TABLE 5-10. DISASSEMBLY/ASSEMBLY OF CAL..50 MACHINE GUN, M2, HB

DISASSY STEP	ASSY STEP	PROCEDURE	FIG/ITEM
1	22	Pull retracting slide handle to rear until lug on barrel locking spring is visible and centered. Twist barrel and remove.	5-14
2	21	Raise cover and remove belt holding pawl pin and link stripper.	5-14
3	20	Remove belt holding pawl pin, belt holding pawl, and springs.	5-14
	*	<b>CAUTION:</b> <u>Make certain bolt is in forward position before next step.</u>	
4	19	Pull outward on lock, upward on latch and slide back plate from receiver grooves.	5-14
5	18	Push driving spring rod assembly forward and to the left until free from hole in side of receiver.	5-14
6	17	Retract retracting slide handle until headless shoulder pin (bolt 5-14 stud) is aligned with slot in receiver and remove bolt stud.	
7		Push bolt to the rear and remove. 5-15	
	16	Raise bolt latch and push bolt into receiver.	
	15	Make certain cocking lever is forward and push bolt into receiver until bolt latch engages notches in top of bolt.	
	*	<b>CAUTION:</b> <u>When installing bolt in next step, do not trip accelerator.</u>	
8		Remove bolt assembly extractor and bolt switch. 5-15	
	14	Install bolt assembly extractor and bolt switch so that grooves 5-15 in switch align with grooves of bolt for left-(L) hand feed.	
9	13	Release bolt assembly firing pin spring by depressing plunger. 5-15	
10	12	Remove bolt assembly cocking lever pin using punch and remove cocking lever.	
11		Remove bolt assembly accelerator stop lock by depressing and rotating to center of bolt. Pry up by using thin end of cocking lever and remove.	5-15
	11	Install accelerator stop lock by placing in position.	5-15
12		Push accelerator stop from opposite side shown, using cocking lever, then pry stop from bolt.	
10		Install accelerator stop and press into position.	5-16
13	9	Remove sear slide, sear, and sear spring.	5-16
	*	<b>CAUTION:</b> <u>Seat sear spring properly.</u>	
14	8	Remove firing pin extension with firing pin and separate.	5-16
15	7	Depress buffer body lock and push barrel extension to the rear. Remove buffer assembly with barrel extension assembly.	5-16
16		Push forward on tips of accelerator and disconnect buffer assembly from barrel extension assembly.	5-16
	6	Hold buffer assembly with accelerator tips up, engage depressor in notch and push forward to engage.	5-16
17	5	Remove buffer assembly from barrel buffer body.	5-16
18	4	Remove accelerator pin and accelerator from buffer body.	5-17
19	3	Remove breech lock pin and breech lock from barrel extension.	5-17
20	2	Remove belt feed lever group and belt feed slide.	5-17
21	1	Turn trigger bar pin assembly, pull out and remove trigger bar.	5-17

**NOTE.** Reverse disassembling step action, as necessary, when assembling.



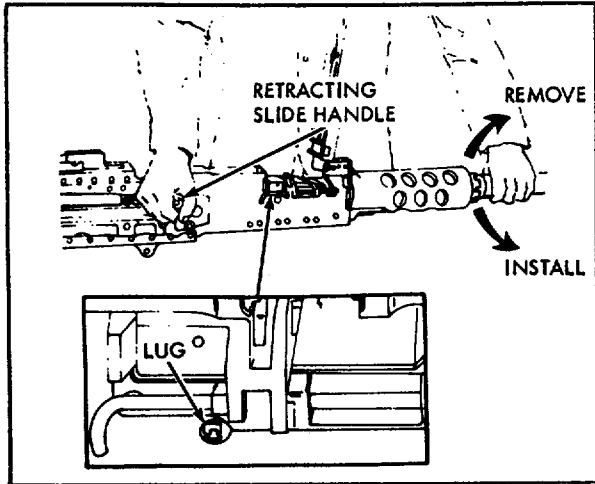

DISASSEMBLE (STEP 1)/ASSEMBLE (STEP 22)

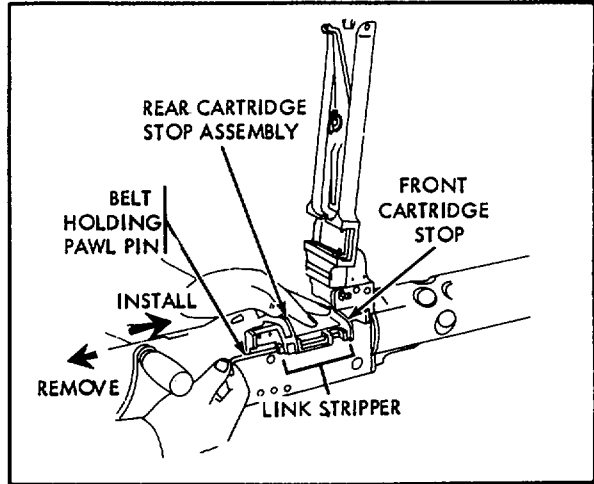

DISASSEMBLE (STEP 2)/ASSEMBLE (STEP 21)

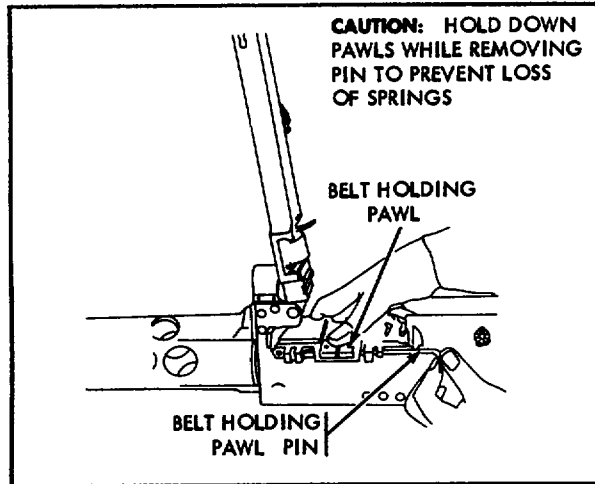

DISASSEMBLE (STEP 3)/ASSEMBLE (STEP 20)

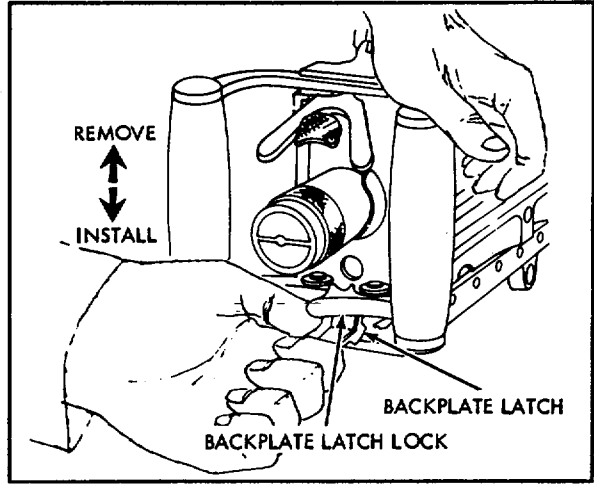

DISASSEMBLE (STEP 4)/ASSEMBLE (STEP 19)

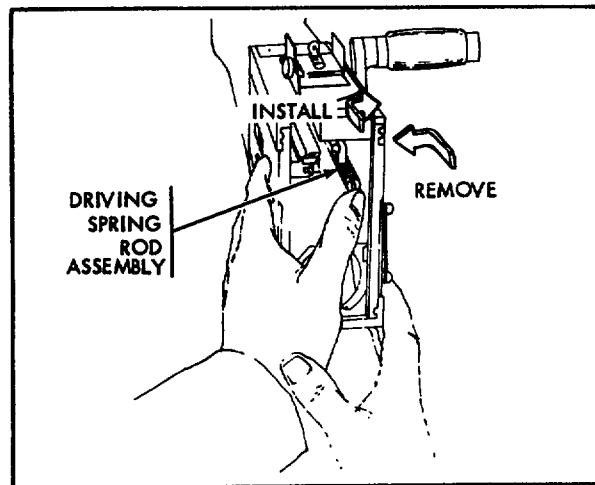

DISASSEMBLE (STEP 5) / ASSEMBLE (STEP 18)

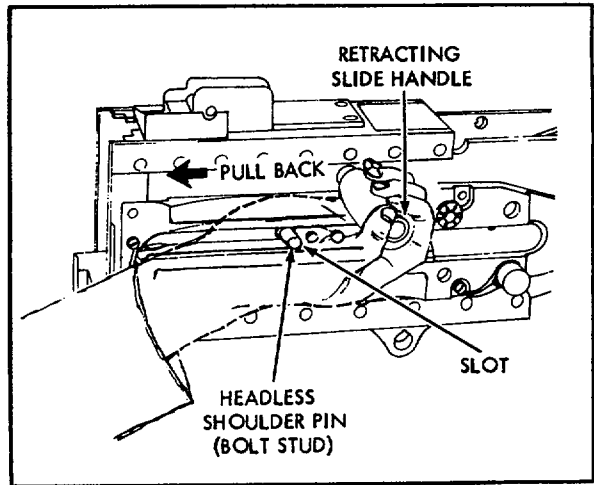

DISASSEMBLE (STEP 6) / ASSEMBLE (STEP 17)

WE 10928

Figure 5-14. Disassembly/assembly - cal..50 machine gun, M2, HB (1 of 4)

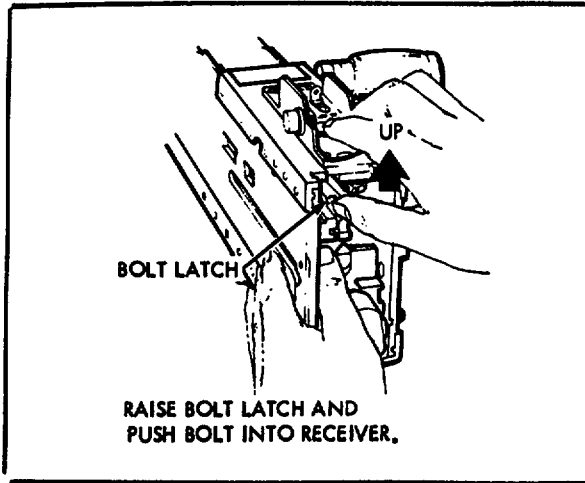

ASSEMBLE (STEP 16)

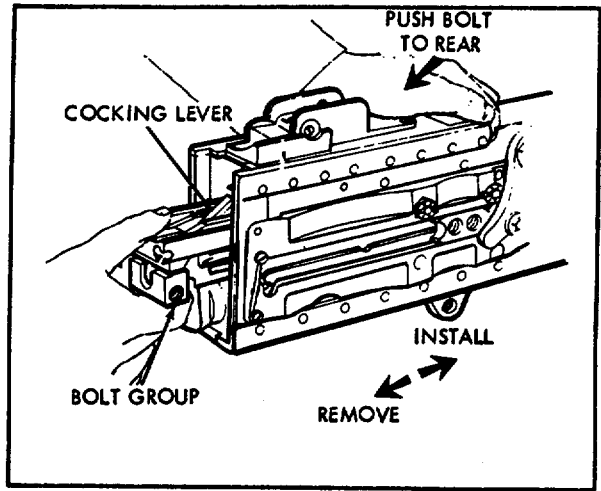

DISASSEMBLE (STEP 7)/ASSEMBLE (STEP 15)

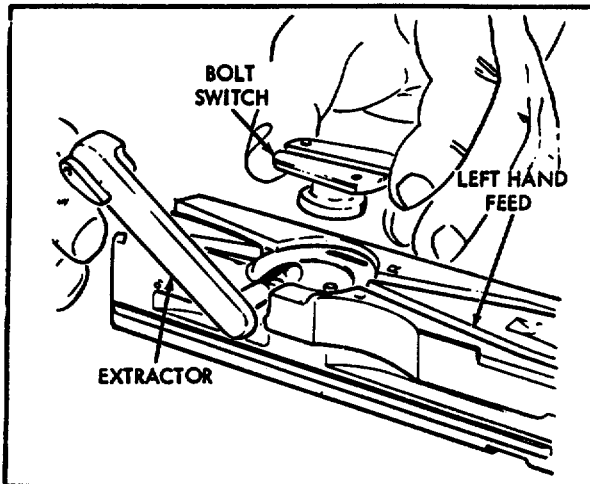

DISASSEMBLE (STEP 8)/ ASSEMBLE (STEP 14)

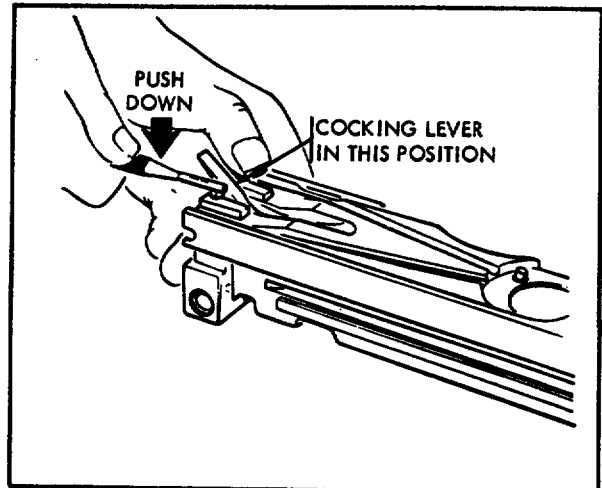

DISASSEMBLE (STEP 9)/ ASSEMBLE (STEP 13)

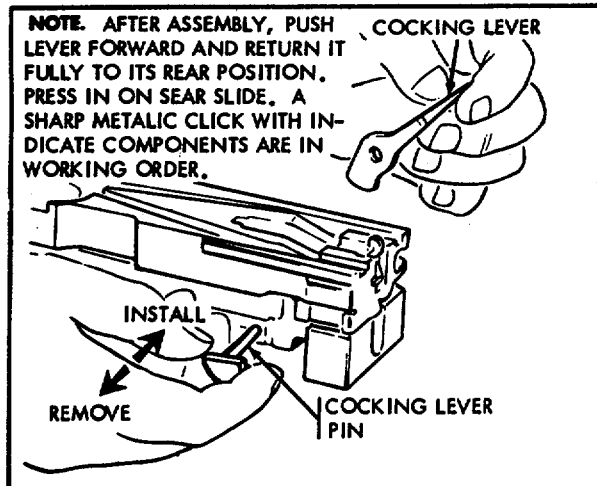

DISASSEMBLE (STEP 10) / ASSEMBLE (STEP 12)

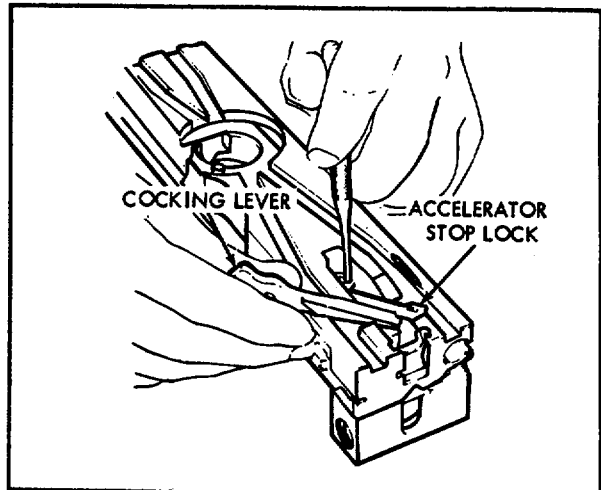

DISASSEMBLE (STEP 11)/ASSEMBLE (STEP 11)

WE 10929

Figure 5-15. Disassembly/assembly - cal..50 machine gun, M2, HB (2 of 4)

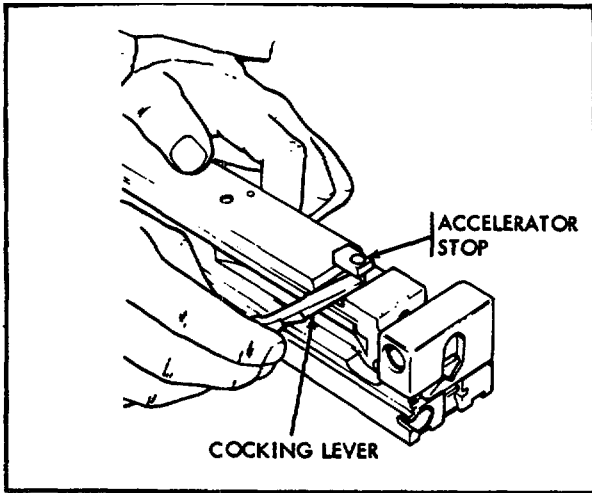

DISASSEMBLE (STEP 12)/ASSEMBLE (STEP 10)

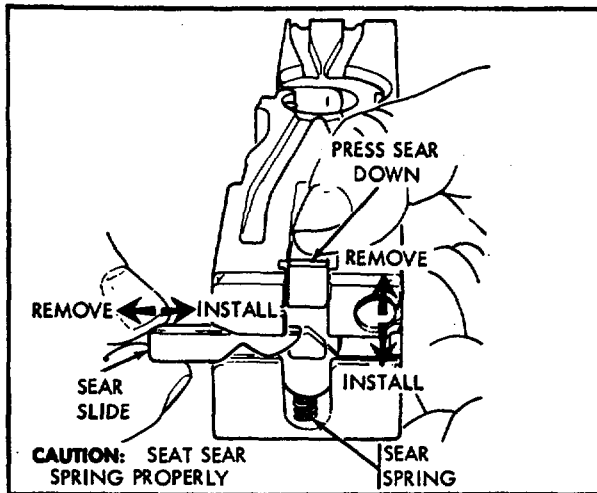

DISASSEMBLE (STEP 13) / ASSEMBLE (STEP 9)

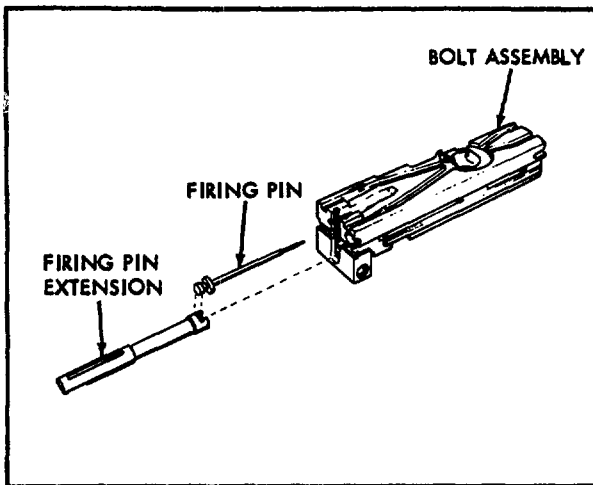

DISASSEMBLE (STEP 14) / ASSEMBLE (STEP 8)

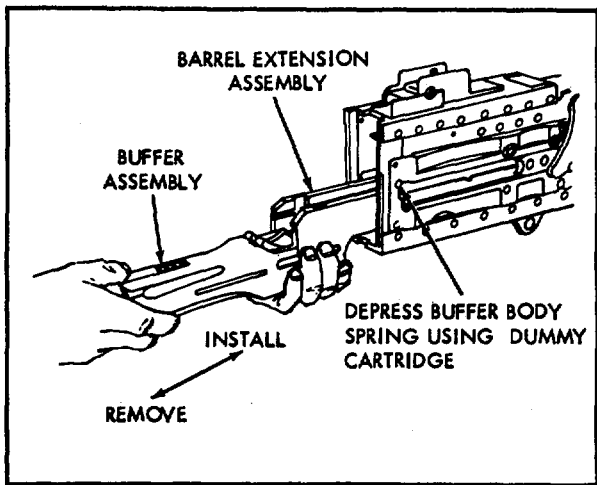

DISASSEMBLE (STEP 15) / ASSEMBLE (STEP 7)

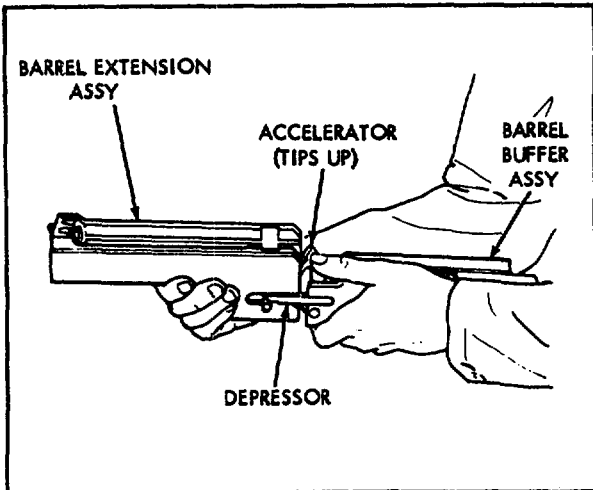

DISASSEMBLE (STEP 16) / ASSEMBLE (STEP 6)

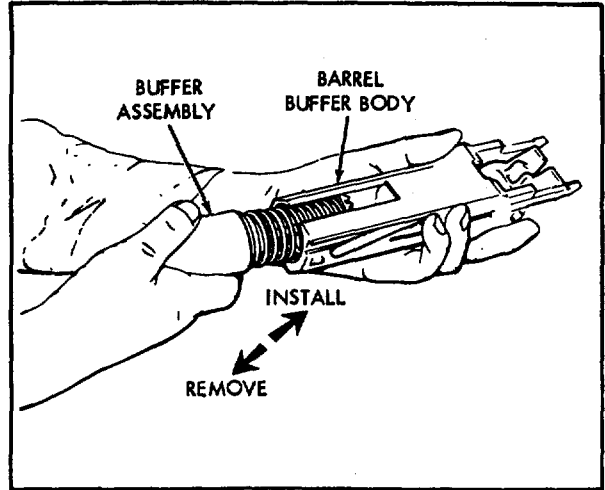

DISASSEMBLE (STEP 17) / ASSEMBLE (STEP 5)

WE 10930

Figure 5-16. Disassembly/assembly - cal. .50 machine gun, M2, HB (3 of 4)



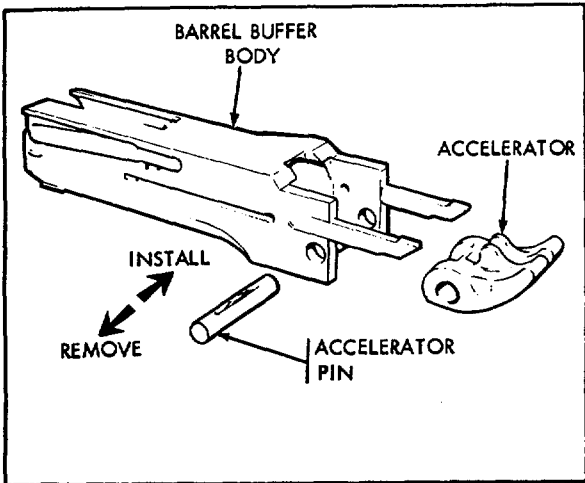

DISASSEMBLE (STEP 18) ASSEMBLE (STEP 4)

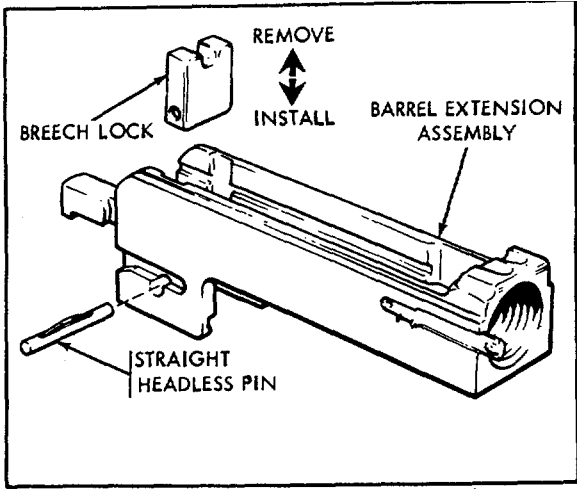

DISASSEMBLE (STEP 19)/ASSEMBLE (STEP 3)

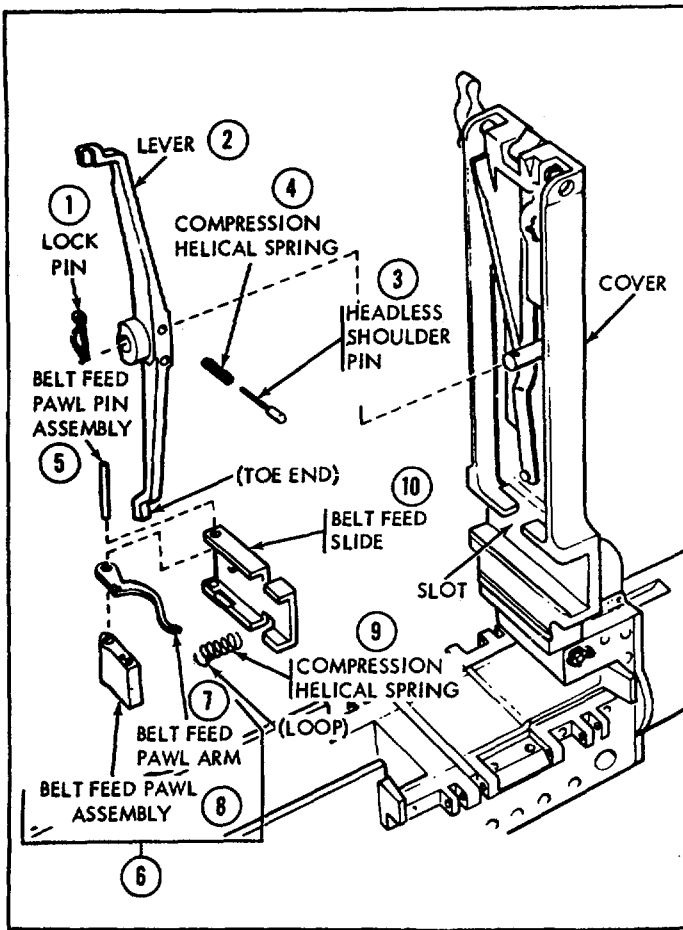

DISASSEMBLE (STEP 20) /ASSEMBLE (STEP 2)

ITEM	NOTE.
2	ALIGN LEVER (TOE END) WITH COVER (SLOT). <b>CAUTION:</b> MAKE CERTAIN THAT ITEM (3) AND (4) DO NOT FLY OUT. <b>NOTE:</b> USE SCREW DRIVER TO HOLD ITEM (3) AND (4) IN PLACE WHEN INSTALLING.
9	PROJECTING OVAL (LOOP) MUST BE AWAY FROM ITEM (7)

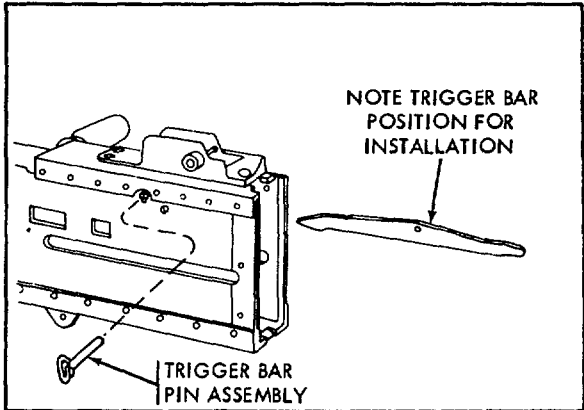

DISASSEMBLE: (STEP 21)/ASSEMBLE (STEP 1)

WE 1093I

Figure 5-17. Disassembly/assembly - cal. .50 machine gun, M2, HB (4 of 4)

**This page is left blank intentionally.**

**CHAPTER 6**  
**PREPARATION FOR AIR-DELIVERY STORAGE,**  
**AND DESTRUCTION OF MATERIEL TO**  
**PREVENT ENEMY USE**  
**Section 6-1. PREPARATION FOR AIR-DELIVERY**

**6-1. Preparation for Air-Delivery**

The crew will lubricate vehicle (LO 9-2350-230-12) and perform all before and/or after operation preventive-

maintenance checks and services. The crew may assist Air Force personnel in preparation of vehicle for air delivery.

TABLE 6-1. PREPARATION FOR AIR-DELIVERY

STEP	PROCEDURE	FIG/ITEM
	<b>CAUTION:</b> <u>Vehicles with serial number 1 through 69 will require blocking under turret rotatable floor prior to air drop.</u>	6-2
1	Disconnect 3 wiring harness quick-disconnectors from cupola traverse control switch assembly.	2-4/2, 4, 6
2	Remove 50 cal.. ammunition tray.	2-4
3	Stow ammunition tray.	6-1
4	Remove machine gun and cradle and pintle assembly.	3-14
5	Stow machine gun and cradle and pintle assembly. Place cushion material in ammunition tray to support machine gun barrel when in stowed position.	
6	Remove 4 screws and flat washers securing pintle support and remove pintle support.	2-4/1
7	Place screws and flat washers in a bag with a 15/16 socket tee wrench and secure to pintle support. Stow support. Place cushion material under pintle support travel lock to prevent damage.	6-1
8	Raise cupola left and right hatch covers, remove 10 screws and hatch covers. Place screws in a bag with 3/4 socket tee wrench, and secure to right hatch cover.	2-4
9	Stow hatch covers and tie down antennas. 6-1	
10	Turn turret control system on (table 2-7).	
11	Depress palm switch of either control handle. Keep handle centered within the system neutral zone.	2-19 and 2-22/11
11.1	On vehicles equipped with spring clips behind air drop knobs, remove spring clips and stow. <u>Clips must be reinstalled</u> after drop.	
12	With palm switch depressed, turn 2 air drop knobs on elevating mechanism clockwise until firm resistance is met, One knob is located beneath handwheel and the other diametrically opposite.	2-19
13	After air drop knobs are firmly in place, release palm switch and turn turret control system off (table 2-7).	
	<b>NOTE.</b> <u>The gun-launcher should be free to move into air-drop padding by applying pressure to end of gun tube. If gun-launcher is not free, follow steps 14 through 17, turn manual elevation handwheel one complete turn and repeat steps 10 through 13.</u>	

TABLE 6-1. PREPARATION FOR AIR-DELIVERY--CONTINUED

STEP	PROCEDURE	FIG/ITEM
<b>AFTER AIR-DELIVERY</b>		
14	Turn turret control system on, table 2-7.	
15	Depress palm switch of either control handle keeping it centered within system neutral zone.	2-19 and 2-21/11 2-19
16	With palm switch depressed, turn 2 air drop knobs on the elevating mechanism counterclockwise until firm resistance is met.	
17	Release palm switch and turn turret control system off, table 2-7.	
<p><b>NOTE.</b> <u>The weapon system is now in manual mode and ready for operation.</u></p>		
18	Install items removed in steps 1 through 9, and 11.1.	
<p><b>NOTE.</b> <u>Remove air drop blocking from under turret rotatable floor prior to operation on vehicles serial No. 1 through 69Y.</u></p>		

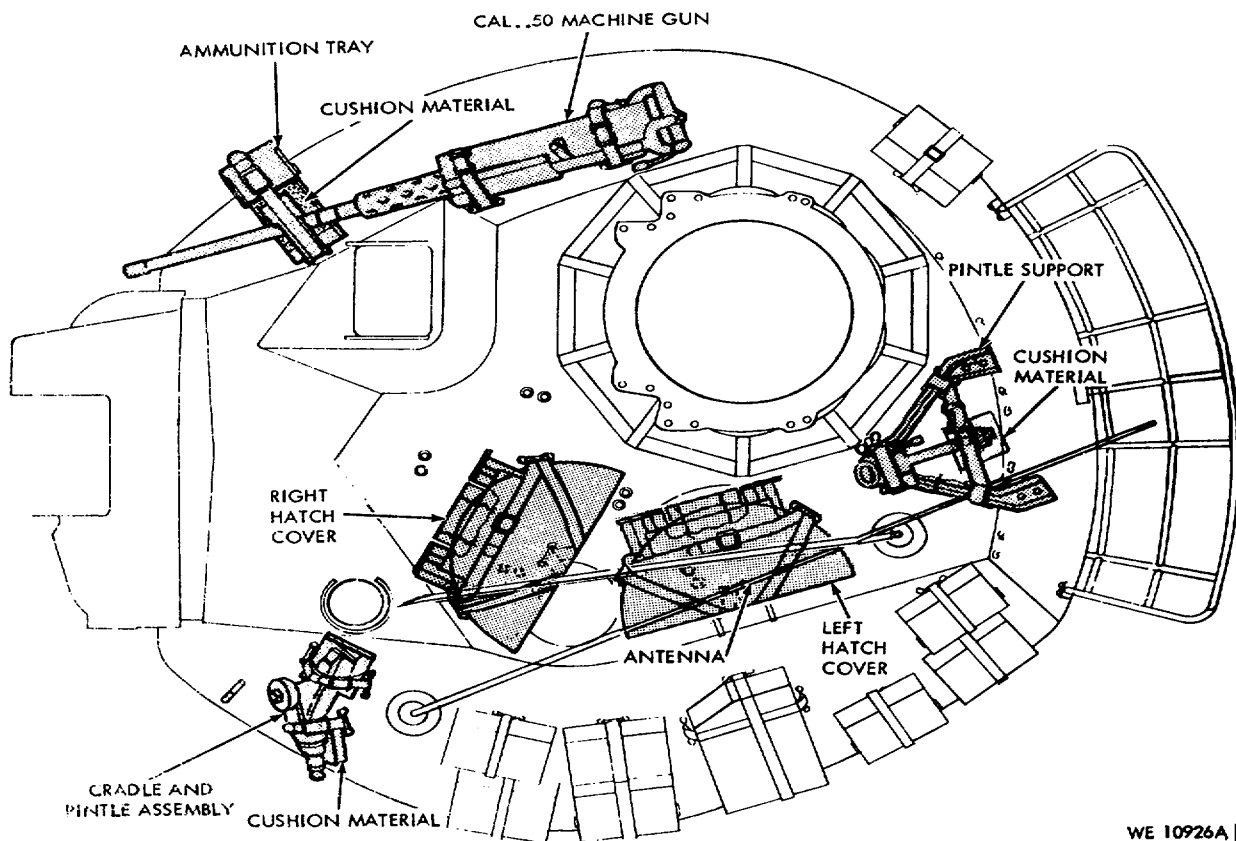

WE 10926A

Figure 6-1. (Superseded) Stowage locations of items removed for air-delivery

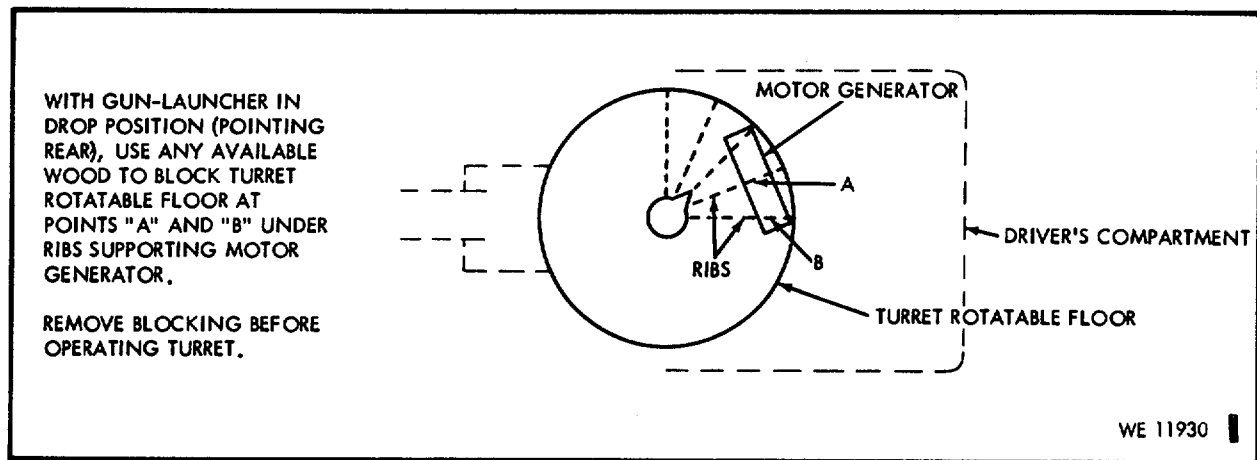

Figure 6-2. (Added) Blocking under turret rotatable floor for air-delivery (vehicles serial no. 1 through 69 only)

## Section 6-2. STORAGE

### 6-2. Servicing and Processing Vehicle for Storage

a. Servicing Vehicle. Perform all before and/or after-operation preventive-maintenance checks and services and lubricate in accordance with LO 9-2350-230-12 (Appendix IV).

b. Processing Vehicle for Storage. Reverse deprocessing vehicle procedure (table 2-1).

### 6-3. Missile Subsystem Shipment and Storage

a. Shipment of Missiles. The shipping and storage container provides adequate shock and vibration protection for the SHILLELAGH missile during transit, provided the containers are securely tied down and braced on the transporting vehicle. During air shipment, a self-operating pressure relief valve protects the missile and container.

#### b. Storage of Missiles.

- (1) Missiles should be stored in buildings designed, designated, and isolated for the specific purpose of storing ammunition as specified in TM 9-1300-206. Explosives and ammunition will not be stored in buildings which are used for other purposes. When specially constructed magazines (as specified in TM 9-1300-206) are not available, the building used must offer

good protection against moisture and must have adequate ventilation.

- (2) Outside storage sites may be utilized when adequate buildings are not available. Missiles stored outside must be stacked 6 inches off the ground on dunnage and covered with paulins or other suitable covering. The covering must allow free circulation of air among the containers. Suitable trenches should be dug to prevent water from running under the stacks.
- (3) Missiles should be stored with NOSE END pointing in the direction which offers the minimum hazard to personnel and property in event of accidental ignition.
- (4) Do not stack more than six-containers high.
- (5) The storage temperature limits on the containers must not be exceeded.
- (6) Missiles must be stored in accordance with quantity-distance classification and storage compatibility group (table 7-1). Distance must be computed using the total explosive weight of the missile (table 7-1).

c. Inspection of Stored Missiles. Missiles stored or held at the organizational unit must be inspected at least weekly (more often if stored outside during bad weather) to insure that the humidity indication does not exceed the "40" level. If the indication exceeds this level, the dessicant and humidity indicator card must be replaced.

d. Shipment of Missile Subsystem Units. Items which are repairable at direct support and general support activities should be provided adequate mechanical and physical protection in transit between the

using and supporting activities. This can be accomplished by a Method m package which provides mechanical and physical protection only. Items to be packaged as follows: Wrap item in chemically neutral paper (FSN 8135-558-1245). Overwrap item in cushioning material (FSN 8135-584-3114) and place in fiberboard container (FSN listed in SB 38-100 by box size). Fill all voides with cushioning material, seal container with tape (FSN 8135-297-6655). Materials are identified in SB 38-100.

**Section 6-3. DESTRUCTION OF MATERIEL TO PREVENT ENEMY USE**

**6-4. Destruction Methods and Priority**

Attempt to salvage sighting and fire control equipment and short supply items prior to destruction.

Destruction must be extensive and by methods and priorities listed in following table so as to prevent repair of cannibalization by the enemy.

TABLE 6-2. DESTRUCTION OF MATERIEL

<b>METHODS:</b>	
Burning.....	Gasoline, oil or incendiary grenades.
Mechanical.....	Axe, crowbar, pick mattock, sledge, or other heavy implement.
Demolition.....	Ammunition or demolition charges.
Gunfire.....	Artillery, hand grenades, or anti-tank rockets.
<b>PRIORITY:</b>	
Missile Sub-system.....	Transmitter
.....	Tracker (mounted on M149 telescope mount).
.....	Signal Data Converter
.....	Modulator
Sighting and Fire Control Equip-ment.....	XM44 Periscope
.....	M119 Telescope
.....	Night Vision Sight (Cal. .50 Machine Gun)
.....	M48 Periscope
152MM Gun-launcher.....	Breech Mechanism
Turret Electric Drive Control.....	Accessory Box
.....	Amplifier Integrator
.....	Power Supply Assembly
.....	Gyro Selector
Missiles.....	Fire in direction of enemy or destroy in conjunction with vehicle.
Machine Guns.....	Receiver
Power Plant.....	Destroy in conjunction with vehicle.

**CHAPTER 7**  
**MATERIEL USED IN CONJUNCTION WITH MAJOR ITEM**

**Section 7-1. 152MM GUN-LAUNCHER GUIDED MISSILES**

**7-1. Firing Tables and Precautions**

a. Firing Tables. DA Pam 310-3.

b. General Firing Precautions. TM 9-1300-206 and AR 385-63.

*TABLE 7-1. SHILLELAGH AMMUNITION DATA CHART*

NOMENCLATURE SURFACE ATTACK	GUIDED MISSILE PRACTICE			GUIDED MISSILE		
	MGM-51A	MGM-51B	MGM-51C	MTM-51A	MTM-51B	MTM-51C
FSN <sup>1</sup>	1410-999-0857	1410-878-7219	1410-878-7219	1410-999-0132	1410-878--7218	1410-878-7218
Part Number	10070000	10154031	10153399	10121359	10153071	10153400
Missile color data; Rocket motor section <sup>2</sup>	Olive drab			Olive drab		
Color of data markings	Yellow			White		
Color code markings of nose cone	Black with 2-inch yellow band over black			Olive drab with 2-inch blue band over olive drab <sup>3</sup>		
Container color data:						
Basic overall color	Olive drab			Olive drab		
Four inch corner squares <sup>4</sup>	Yellow			Brown		
Data marking color	Yellow			White		
ICC shipping name on container	ROCKET AMMUNITION WITH EXPLOSIVE PROJECTILE			ROCKET AMMUNITION WITH INERT LOADED PROJECTILE		
Shipping classification	CLASS A EXPLOSIVE			CLASS B EXPLOSIVE		
ICC placard type	EXPLOSIVE			DANGEROUS		
Quantity distance classification	7			2		
group	F			F		

<sup>1</sup> FSN applies to the missile and container as a unit of issue.

<sup>2</sup> Live rocket motor will have a 2-inch brown band around the motor case.

<sup>3</sup> The word INERT is stamped on the blue band in four places, 90 degrees apart.

<sup>4</sup> Container corner markings are on diagonally opposite corners.

TABLE 7-2. SERVICE UPON RECEIPT OF MISSILES

ITEM	ACTION REQUIRED
<p><b>MISSILE CONTAINERS:</b>            Data Marking and Color Coding .....            Lead Seals.....            Surfaces. ....            Humidity Indicator .....</p>	<p>Make sure correct type of missiles has been received.            Must not be broken from latches.            Must not be punctured.            "40" and "50" dots must not be pink.</p> <p><b>NOTE.</b> <u>If containers are defective do not open. Return MISSILES to ammunition supply point. Report discrepancies on DA Form 2415.</u></p>
<p><b>MISSILES</b>.....</p>	<p style="text-align: center;"><b>REMOVAL</b></p> <p><b>NOTE.</b> <u>Except to perform inspections required in Table 7-2. 1, missile containers must not be opened until immediately prior to stowing missiles in vehicle.</u></p> <ol style="list-style-type: none"> <li>1. Depress pressure relief valve on container lid to relieve any pressure.</li> <li>2. Cut seals, unlatch and remove container lid.</li> <li>3. Remove missile from container.</li> </ol> <p><b>NOTE.</b> 1. <u>Exercise care in unpacking missiles from containers to avoid denting or damaging missiles.</u>            2. <u>If humidity indicator "40" or "50" dot is pink return missile and container to ammunition supply point.</u></p> <ol style="list-style-type: none"> <li>4. Replace lid on container.</li> <li>5. Return all containers that are excess to unit requirements to the ammunition supply point.</li> </ol>
<p>Surface .....</p>	<p>Must not be dented, cracked, scratched, or corroded.</p> <p><b>WARNING:</b> <u>Reject all HEAT warhead missiles that have dented nose cones.</u></p> <p><b>NOTE.</b> <u>Scratches that have not displaced metal are permitted.</u></p>
<p>Shorting Connector.....</p>	<p>Must fit tight and its surface must not be higher than surface of missile skin. FWD arrow must point toward nose cone.</p>
<p>Assembly Attachment Points.....</p>	<p>All must fit tight and joints at attachment points must not be loose.</p>
<p>Nose Cone Seam .....</p> <p>Color Coding and Data Markings .....</p>	<p>Must not be separated.            Make sure correct type of missiles have been received.</p>



TABLE 7-2. SERVICE UPON RECEIPT OF MISSILES - Continued

ITEM	ACTION REQUIRED
<b>MISSILE AFT COVER:</b>	
Shear Screws	Must be tight.
Ejector Rim	Must not be dented.
Adapter Stop	Must not be dented.
Cushioning Pads	Not rolled or defaced.
Observation Windows	Tight and not cracked. No evidence of internal moisture.
Firing Contractor	Must fit tight.
Diaphragm	Sealed and has no punctures.
<b>NOTE.</b> IF missile fails to pass any of the above checks, repack missile in its container and return to ammunition supply point. Report discrepancy on DA Form 2415.	

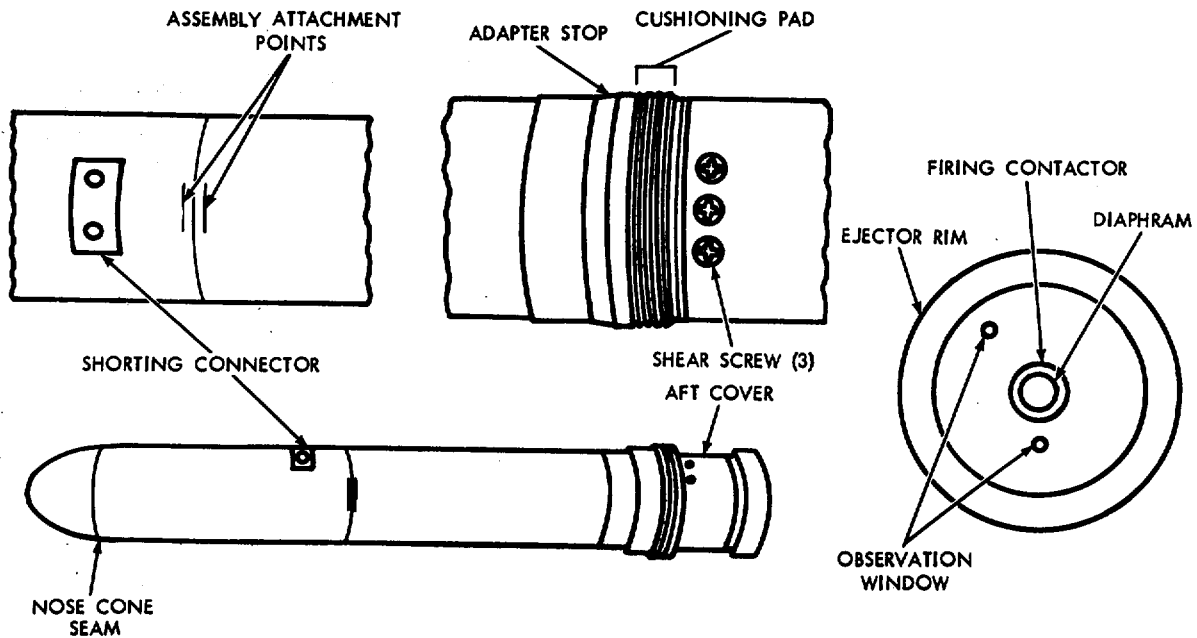

WE 10910

Figure 7-1. Missile inspection points

TABLE 7-2.1. SHILLELAGH AMMUNITION PERIODIC INSPECTION REQUIREMENTS

ITEM	INSPECT
<p><b>NOTE.</b> <u>Semiannual inspection will be performed by a contact team from the ammunition company. Notify the supporting organization where inspections can be scheduled.</u></p>	
<p><b>MISSILE CONTAINERS:</b></p> <p>Humidity Indicator</p>	<p>Inspect the humidity indicator on all containers on a monthly basis, in accordance with table 7-2.</p>
<p><b>MISSILE AND CONTAINER:</b></p> <p>Dummy Guided Missile M29 and M29A</p>	<p>Semiannual visual inspection on a sampling basis of basic load stock.</p> <p>Annual missile test on a sampling basis of basic load stock.</p> <p>Semiannual visual inspection will be performed on all dummy missiles.</p>

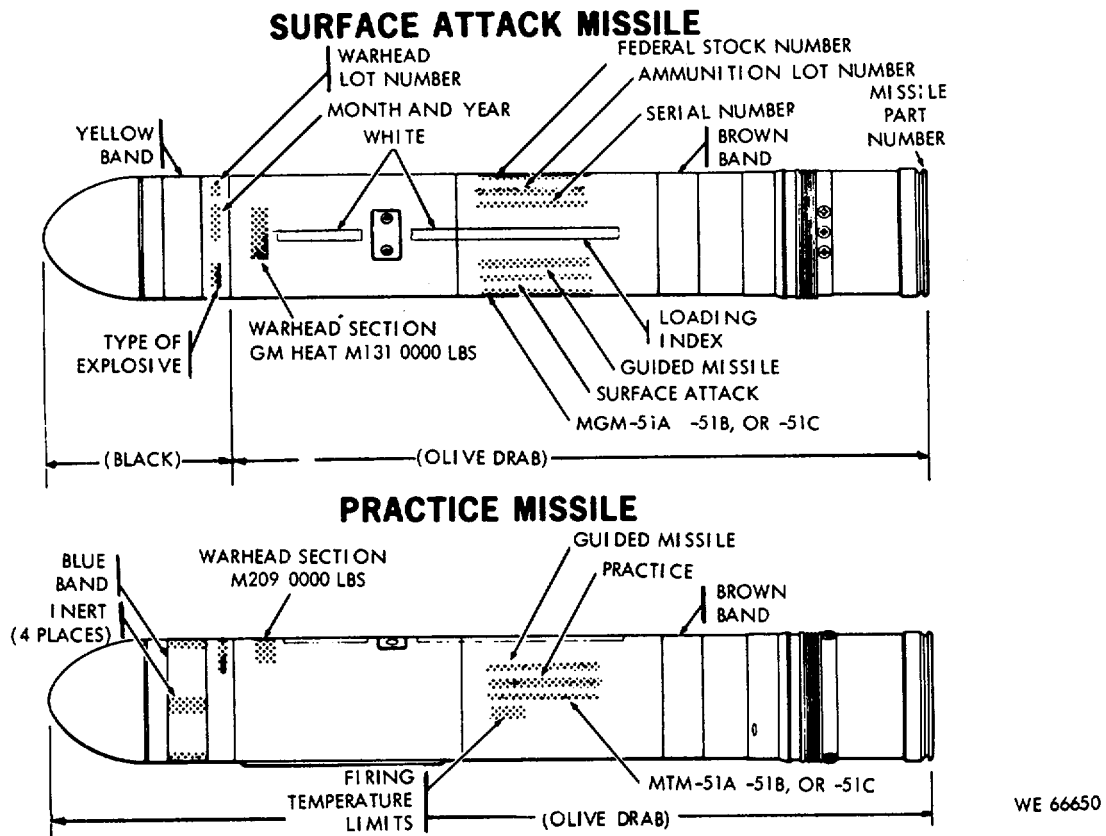

Figure 7-2. Missile identification

**Section 7-2. CONVENTIONAL AMMUNITION FOR  
152MM GUN-LAUNCHER M81 SERIES**

**7-2. General**

a. Conventional ammunition for 152MM Gun-Launcher M81/M81E1 is classified as fixed ammunition. The complete round is issued with projectile assembled to the cartridge case. The propelling charge is not adjustable.

b. A complete round of ammunition consists of all components required to fire the weapon once. These components consist of a primed cartridge case containing the propelling charge and a projectile, fuzed or unfuzed depending on type. The complete round is loaded into the weapon as a unit. Dummy round, a one piece inert round made of cast aluminum, is used for training in loading and handling.

c. Authorized cartridges, round types and fuze types are given in table 7-3, and illustrated in figures 7-3.1 through 7-3.4.

**7-3. Firing Tables**

Refer to FT 152-A-1.

**7-4. Identification**

a. General. Ammunition, ammunition components, and packing containers are identified by painting and marking. Complete rounds are identified by color scheme and marking.

- (1) Model. A model designation, assigned to identify a particular design, is included in the marking. Model designations consist of M or XM and an arabic numeral. Modifications are indicated by adding A or E and an arabic numeral. M1A1, for example, indicates the first modification of an item for which the original designation was M1. XM 409E5, as another example indicates the fifth modification of an item originally designated XM409.
- (2) Ammunition lot number. When ammunition is manufactured, an ammunition lot number, consisting of the manufacturer's symbol and a number, is assigned.

b. Painting. Artillery projectiles are painted to prevent rust and to provide a ready means of

identification. Color codes used are given in table 7-3.

**7-5. Authorized Rounds**

Only authorized cartridges will be used in this weapon. Specific information, Federal Stock Numbers and other pertinent data are listed in SC 1305/30-IL and SC 1340/98-IL.

**7-6. Preparation for Loading**

a. General. Cartridges for 152MM Gun-Launcher M81 series are fixed rounds and require no preparation for firing except unpacking and inspection. Rounds are marked for identification as shown in figure 7-3.1 through 7-3.4.

b. Firing Temperature Limits. Observe the following safe temperature limits:

For all models except HE-T cartridge XM657E2:

Upper limit ..... +1250F  
Lower limit ..... -40 F

For HE-T cartridge XM657E2 only:

Upper limit ..... +1250F  
Lower limit ..... t40 F

**NOTE.** Ammunition kept clean, dry, and at uniformly moderate temperatures gives greater accuracy of fire. Successive firing of cartridges from the same lot minimizes dispersion at the target.

c. Special Instructions for Cartridge Canister, M625 Series.

**WARNING:** Before firing, assure that all personnel are clear of dispersion area proper and are under cover in immediate vicinity.

Canister cartridge M625 series is a flechette-loaded, beehive type which functions immediately in front of the weapon. The flechettes are dispersed in a conical pattern (fig. 7-3.5). This presents no hazard to personnel except in the cone area and immediate vicinity.

**NOTE.** Before firing canister cartridge, adjust telescope reticle for a range of 1400 meters. This assures desired gun elevation of 17 mils.

d. Unpacking and Stowing.

**NOTE.** Retain packing materials for repackaging, as required.

(1) Packaging.

(a) In order to protect the nonmetallic cartridge case from moisture, each round is packed in an elastomeric (stretchy rubber) or neoprene barrier bag as follows:

(1) Rounds with cartridge cases M205 (table 7-3) are packed in elastomeric barrier bags. These cover the cartridge case and extend flat up the projectile body beyond the rotating band.

(2) Rounds with cartridge cases M157 series (table 7-3) are packed in neoprene barrier bags. This bag covers the cartridge case and is drawn tight around the base of the projectile, with a cuff folded back. On cartridge M625 XM625) ONLY, the bag extends flat up the projectile body.

(b) A warning stenciled on each bag advises the user to "REMOVE THIS BAG IMMEDIATELY PRIOR TO FIRING."

(2) Marking of packaging. Markings on outer and inner pack are given in table 7-3.1.

(3) Procedure.

(a) Examine ammunition box markings to determine identification.

**CAUTION:** Do not use axes, crow- bars or other implements which may damage inner pack or ammunition.

(b) Open outer pack.

(c) Remove bagged fiber container.

(d) Remove laminated barrier bag covering fiber container.

(e) Open fiber container and remove bagged cartridge and desiccant bags.

(f) Immediately inspect projectile and outside of barrier bag for moisture. Reject rounds which fail to pass this inspection and return to ASP for disposition. Do not use humidity indicator card on bag as I inspection criterion,

**CAUTION.** Do not remove barrier I bag which covers cartridge case until round is being chambered.

(g) Check markings on projectile to confirm identification of round.

(h) Before placing round in stowage rack, fit protective cover (issued with vehicle) over cartridge case. Unfold cuff of barrier bag so that it extends flat, covering projectile rotating band inside protective cover.

**NOTE.** This protective cover is used over elastomeric and neoprene barrier bags as additional protection for ammunition stowed on board vehicle.

Figure 7-3-deleted.

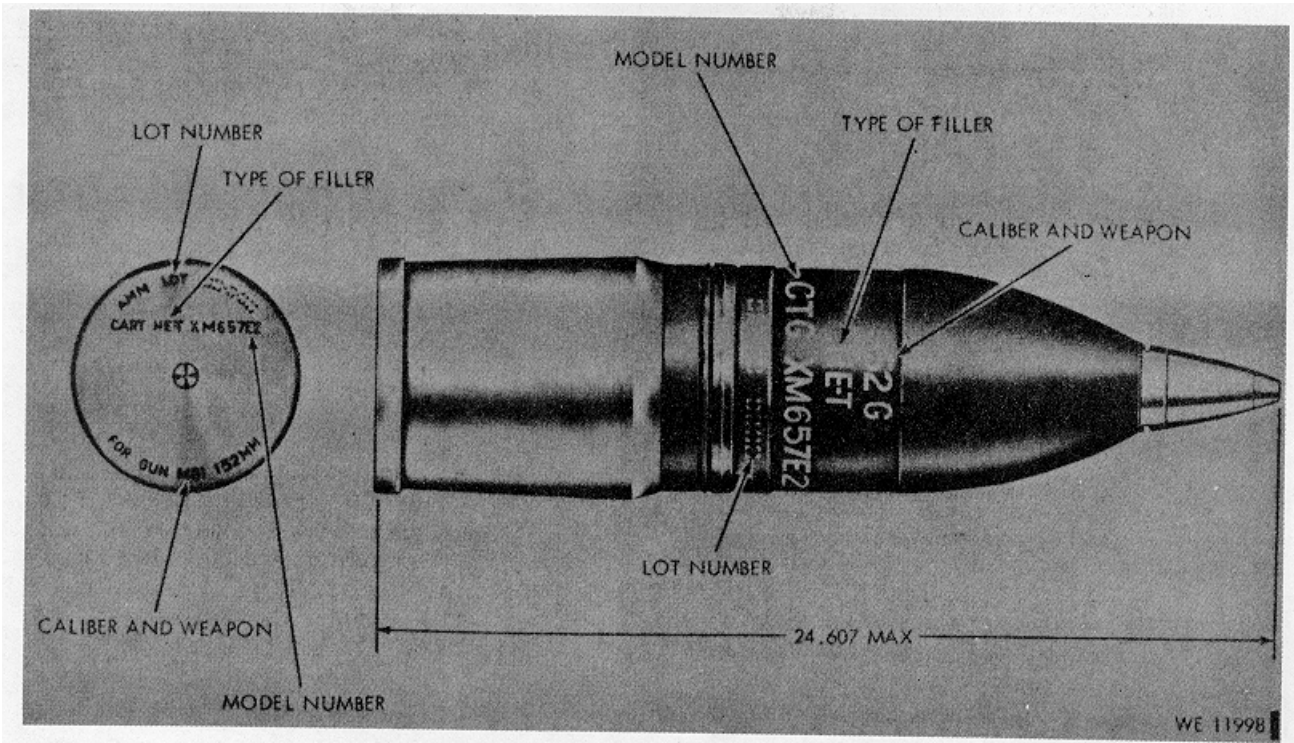

Figure 7-3.1. 152MM HE-T cartridge XM657E2

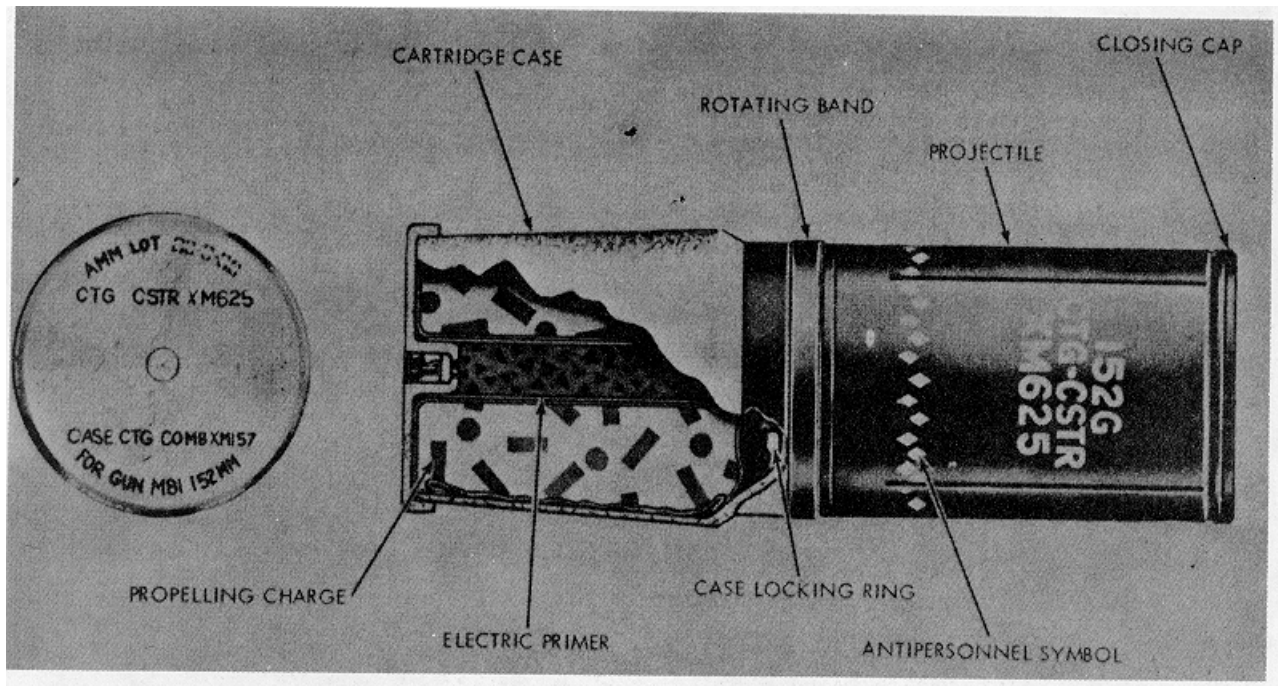

Figure 7-3.2. 152MM canister cartridge XM625

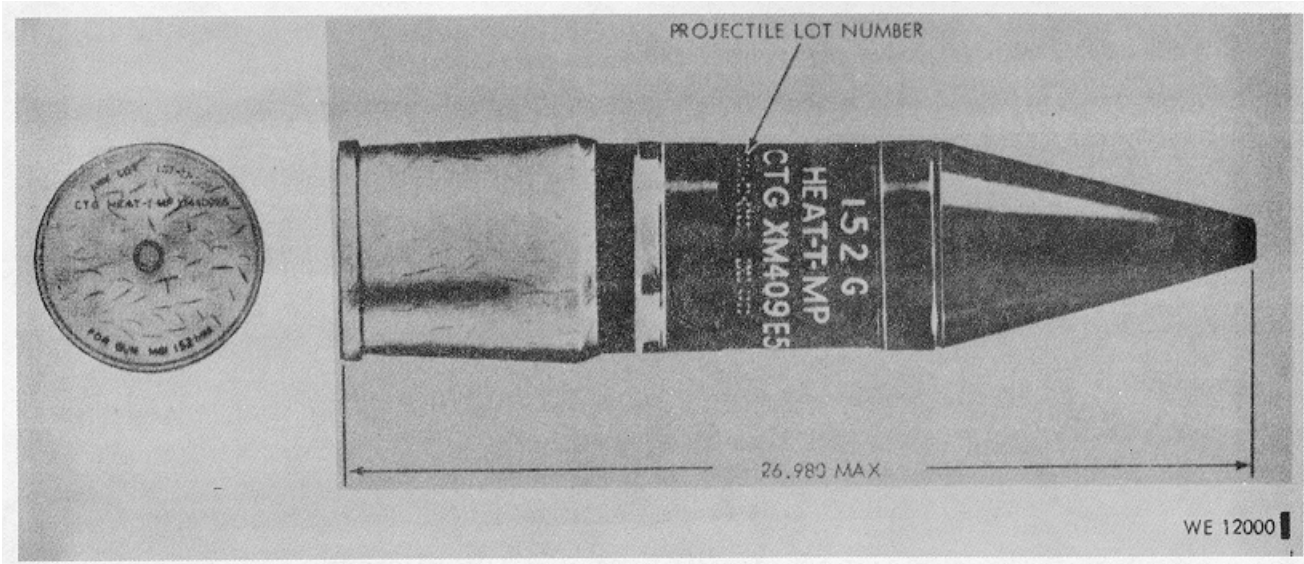

Figure 7-3.3. 152MM HEAT-T-MP cartridge XM409E5

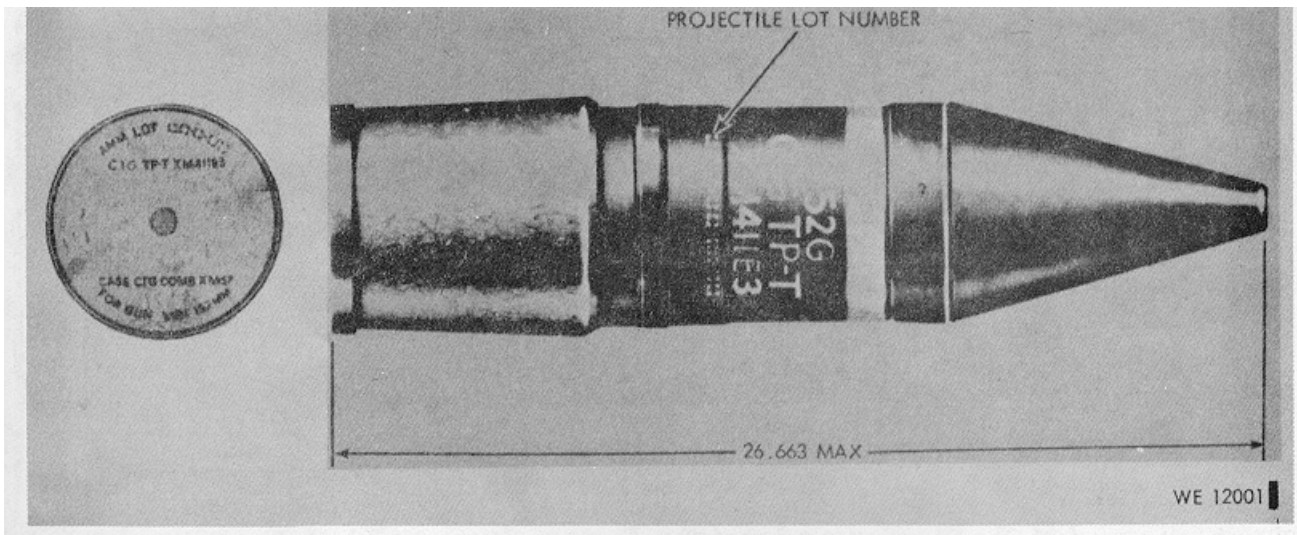

Figure 7-3.4. 152MM TP-T cartridge XM411E3

7-4.4

TABLE 7-3. ROUND TYPES AVAILABLE FOR 152MM GUN-LAUNCHER M81 SERIES

ROUND	IDENTIFICATION		MARK	LOADING OF ROUND	ACTION OF FUZE	TACTICAL USE
	CARTRIDGE CASE	COLOR OF PROJ				
Cartridge, 152-mm: HE-T, XM657E2 w/ Fuze, PD: XM720E1	XMI57	Olive drab	Yellow	High explosive, TNT	Super-quick	Antipersonnel, antimateriel
Cartridge, 152-mm: HEAT-T-MP, M409A1 w/Fuze, PIBD: M539	M205	Black quick	Yellow	High explosive, shaped charge (Comp B), tracer	Super-	Armor defeating, anti-personnel, antimateriel
Cartridge, 152-mm: HEAT-T-MP, M409 (XM409E5) w/Fuze, PIBD: M539 (XM539E4)	M157	Same	Same	Same	Same	Same
Cartridge, 152-mm: Canister, M625A1	M205	Olive drab	White (white diamonds indicate flechettes)	Flechette	Unfuzed	Antipersonnel (effective in dense foliage)
Cartridge, 152-mm: Canister, M625 (XM625)	M157	Same	Same	Same	Same	Same
Cartridge, 152-mm: TP-T, M411A3	M205	Blue	White	Inert projectile with tracer	Unfuzed	Target practice
Cartridge, 152-mm TP-T, M411A2	M157	Same	Same	Same	Same	Same
Cartridge, 152-mm: TP-T, M411A1 (XM411E4)	M157	Same	Same	Same	Same	Same
Cartridge, 152-mm:	M157	Same	White with one yellow band	Inert projectile w/ live fuze, tracer, and spotting charge	Super quick	Same
Cartridge, 152-mm: Dummy M596	Blue	White	Inert	Unfuzed	Training	

**NOTE. APPROXIMATELY A 10.5-METER INCREASE IN ARC WIDTH RESULTS FOR EACH ADDITIONAL 50 METERS OF RANGE.**

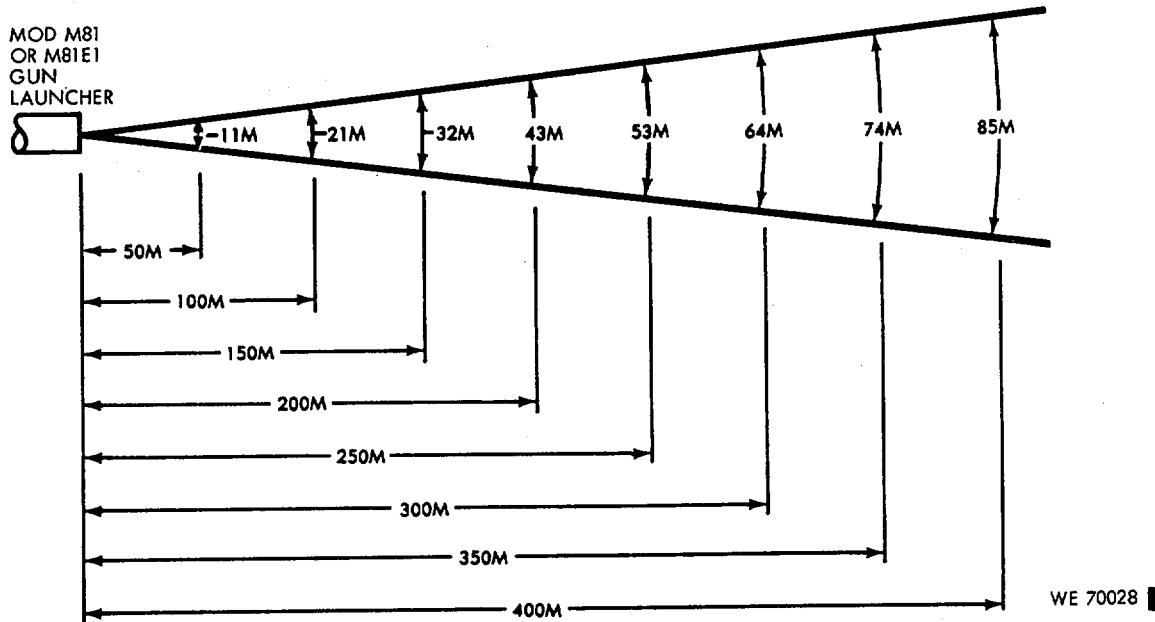

Figure 7-3. 5. Dispersion pattern - canister cartridge M625 series.

Table 7-3.1. Marking of Packaging

Markings	Outer Pack	Inner Pack (Fiber Container)
Department of Transportation (DOT) Shipping Designation	X	
Federal Stock Number (FSN) and Department of Defense Identification Code (DODIC)	X	
Department of Defense Ammunition Code (DODAC)	x	
Ammunition Lot Number	X	X
Gross weight of packing container and contents	X	
Cubical displacement of packing container	x	
Date manufactured	X	
Descriptive nomenclature of packed item	x	x
Caliber and weapon designation	X	X



**7-7. Preparation for Firing**

- a. Remove ballistic protective cover. Remove round from rack.
- b. Assure that round is free of sand, mud, snow, ice, grease or other foreign matter. Contamination may result in hot residue in gun chamber.
- c. Check cartridges visually for damage to projectile body, ogive, rotating band and band coating which might result in difficulty in chambering the round.
- d. Do not use firing mechanism adapter when firing rounds assembled with cartridge cases M205.
- e. Assure that area to rear of forcing cone in tube and chamber is clear of residue.
- f. Assure that internal portion of breech U (including firing mechanism) and chamber of cannon are dry.
- g. Remove barrier bag as cartridge is shoved into gun tube, checking for obvious case and primer damage which might result in difficulty in chambering the round.
- h. If any pieces of smoldering residue are visible after firing, do not remove barrier bag of subsequent round until residue is extinguished and gun tube cleared.
- i. In case of misfire, check for dirty firing mechanism. Clean firing mechanism before replenishing main gun ammunition.

**WARNING:** Inspect unpacked cartridges which have been dropped for separation of cartridge case from projectile; separation of base of case from case body; open cracks in cartridge case; dented projectiles; and loose windshields (nose caps). Return rejected cartridges to ASP for disposition.

\_\_\_\_j. Strict observance of firing temperature limits is mandatory (para 7-6b).

**NOTE.** Barrier bags may be difficult to remove at -250F or below.

- k. If firing is interrupted, remove round From chamber of hot weapon promptly to prevent cook-off. (See chapter 3).

**NOTE.** Repeated loading and unloading of the same round may result in a misfire.

**7-8. Cartridges Prepared for Firing But Not Fired**

**CAUTION:** Do not reuse cartridges which have been ejected from weapons by ramming. Ejection difficulty may have been caused by some nonstandard condition in the ammunition and, also, the fuze may have been damaged during the ramming process.

- a. Assure that detent pin is in the retracted position prior to any removal action. (Detent pin must be held in retracted position while round is being dechambered).
- b. Do not use missile cap extractor to remove round from chamber. (Extractor is intended only for fired missile cap.) Ram cartridge gently if it cannot be removed by hand. Take care to catch rammed round before it drops to floor of vehicle.
- c. Holding round securely replace barrier bag and ballistic protective cover. Stow in appropriate rack and use first in subsequent firings.
- d. If ammunition is subsequently returned to ASP, repack in original packing, including barrier bag.

**7-9. Maintenance****WARNING:**

1. Do not expose ammunition to extreme temperatures. Do not expose to direct sunlight, flame or other sources of heat. (Non-metallic cartridge cases used with this ammunition are easily ignited by cigarette embers, smoldering residue, etc.)
2. Handle explosive ammunition with utmost care. Do not drop, drag, throw, tumble or strike packaged or unpackaged ammunition. (Explosive elements in primers and fuzes are sensitive to shock.)
3. Do not expose ammunition to rain, excessive humidity or ground moisture. (Otherwise, short ranges and excessive residue may result.) Protect electric primer from sources of electricity to preclude accidental functioning.

a. Care.

- (1) Ammunition is packed to with stand conditions ordinarily encountered in the field. Keep packing boxes from becoming broken or damaged.
- (2) Since ammunition is impaired by moisture, frost, extreme temperatures and foreign matter (mud, oil, etc.), observe the following:
  - (a) Do not break moisture-resistant seal on container until ammunition is to be used or stowed in vehicle.
  - (b) Shield ammunition from sources of high temperatures (e.g., direct rays of sun).

b. Handling.

- (1) Cartridge cases are damaged easily; protect from hard knocks and blows.
- (2) Protect cartridge during handling from moisture and foreign matter. Do not remove barrier bag until round is being chambered.
- (3) Protect fuzes, primers) and rotating bands at all times from foreign matter and impact.

c. Maintenance.

**WARNING:** Never alter ammunition or components.

- (1) Procedures.

**CAUTION:** Do not remove barrier bag during inspection of unpacked ammunition.

- (a) Inspect packaged ammunition stored in dry, cool and well ventilated indoor storage at least once a year. Inspect packaged ammunition protected only against direct rain and sunlight (e.g., tarp covered, outdoor storage) at least once a month. Inspect unpackaged ammunition in storage and outside of packaged ammunition exposed to direct rain or sunlight once a day. Open boxes or containers which show evidence of severe contamination or deterioration, and inspect ammunition. Do not open sealed boxes or containers for inspection purposes only.

- (b) Inspect tank-stowed or other unpacked ammunition every three months (preferably during vehicle quarterly maintenance inspection). Conduct as below:

1. Examine barrier bag for nicks, tears, and loose fit.
2. Without removing barrier bag, examine each round. Reject for separation of cartridge case from projectile or separation of base of case from case body.
3. Repack rejected rounds (see below, paragraph 7-9\_(3)), marking container to indicate type of damage. Return rejected rounds to ASP for disposition. ASP or higher echelon may remove bag and visually inspect round for disposition purposes.

- (c) Protect bagged cartridge cases from exposure to water or oil as follows:

1. Fix oil and water leaks in vehicle promptly.
2. Close hatches before hosing down outside of vehicle.
3. Take care, when lubricating internal parts of hull or turret, to prevent oil or grease contamination of either ammunition or stowage racks.

- (2) Ammunition prepared for firing. But not fired.

- (a) Return such ammunition to original condition and packing.
- (b) Include barrier bag and laminated barrier bag as part of repacking operation.
- (c) Mark appropriately and use first in subsequent firings in order to keep stocks of open packings to a minimum.

(3) Unserviceable ammunition.

- (a) Conspicuously mark unserviceable - ammunition or explosive components UNSERVICEABLE, and return to ammunition supply personnel for disposition.
- (b) Repackage ammunition in original - containers. If original container is unsuitable, use expended packing material and transfer all markings. Conspicuously mark all layers of packing UNSERVICEABLE.

c. Provisions.

- (1) Use heavy, well supported dunnage to keep bottom tier of stack off ground and to prevent it from sinking into ground.

**NOTE.** A hard stand of blacktop or gravel and sand is preferable to excessive use of dunnage.

Allow at least 6 inches of space beneath pile for air circulation. Dig suitable trenches to prevent water from flowing under pile.

- (2) Provide nonflammable or fire resistant covers (e.g., tarpaulin) for all ammunition. Maintain an air space of approximately 18 inches between cover and ammunition. Keep cover at least 6 inches from pile on ends and at sides, to permit circulation of air.
- (3) Store ammunition containers with top sides up. (Labels or markings on boxes and containers indicate which side should be up.)
- (4) Minimum distances permitted between given quantities of 152MM rounds and inhabited buildings, etc., for ammunition in quantity-distance class 5 (TP-T and canister) and class 7 (HE-T and HEAT-T-MP) are indicated in TM 9-1300-206.

Paragraphs 7-11 and 7-12 - deleted.

**7-10. Storage**

**WARNING:** Avoid exposure of ammunition and ammunition components to direct sunlight. (Ammunition exposed directly to sunlight, or in unventilated containers, inclosures, shelters, freight cars, closed vehicles and similar structures exposed to direct sunlight, may reach temperatures exceeding upper storage limits.)

a. Storage Temperature Limits. Except as otherwise specified, observe the following limits;

Lower limit: -650F.  
Upper limit: +1450F.

b. Sites.

**WARNING:** Do not store ammunition under trees or adjacent to towers or other structures that attract lightening.

When ammunition must be stored in the open, select a storage site free of power lines, electric cables and readily ignitable and flammable materials. Sites should not be adjacent to reservoirs, water mains or sewer lines. Sites should be level and well drained.

(7-4. 10 blank)/7-4. 9

**Section 7-3. COMMUNICATIONS EQUIPMENT****7-13. Communications Data**

The following tables and illustrations provide data for communications equipment. Additional information will be found in TM 11-5820-401-10 and TM 11-5820-498-10.

a. Radio Set AN/VRC-12. The AN/VRC-12 can monitor two channels simultaneously, or one channel can be monitored while transmitting on the other, and has ten (10) preset channels.

b. Radio Set AN/VRC-46. The AN/VRC-46 is similar to the AN/VRC-12, except that monitoring an additional channel is not possible. Also, the receiver-transmitter is manually tuned; no preset channels are available.

c. Radio Set AN/VRC-47. The AN/VRC-47 is used in installations where preset channels are not required. Two channels can be monitored simultaneously or one channel can be monitored while transmitting on the other channel.

d. Radio Set AN/VRC-53. The AN/VRC-53 consists of receiver-transmitter RT- 505/PRC- 25 and amplifier-power supply OA-3633/GRC, and provides short range communication with crew served vehicles and other support elements.

e. Amplifier, Audio Frequency AM-1780/ VRC. The AM-1780/VRC is used to select the mode of operation, to provide connections to an external field telephone, and to amplify the intercom and radio signals.

f. Universal Communications Harness for AR/AAV, FT, 152MM, M551. The universal communications harness consists of antennas, adapters, cables, mounts, the AN/VIC-1 (VC), control boxes, and is installed equipment.

g. Controls, Intercommunication Set C-226/V RC, C-2297/VRC, and C-2298/VRC. The C-2297/VRC and C-2298/VRC are used to provide intercom facilities and to extend use of the radio set to crew members. The C-2296/VRC includes a handset which permits personnel outside the vehicle to communicate with those inside and to use the facilities of the radio set.

TABLE 7-4. RADIO SETS AN/VRC (BASIC UNITS) AND INTERCOMMUNICATION EQUIPMENT

MAIN ITEMS COMPRISING AN OPERABLE EQUIPMENT	QUANTITY PER RADIOSET			
	12	46	4	53
Receiver-Transmitter Radio RT-246/VRC (fig. 7-4)	1	0	0	0
Receiver-Radio R-442/VRC (fig. 7-4)	1	0	1	0
Cover CW-649/VRC	1	0	1	0
Receiver-Transmitter, Radio RT-524/VRC	0	1	1	0
Cover CW-653/VRC	1	1	1	1
Amplifier-Power Supply AM-2060/VR	0	0	0	1
Receiver-Transmitter RT-505/PRC-25	0	0	0	1
Universal Communications Harness	(1)	(1)	(1)	(1)
Installed Equipment Consisting of:				
Mounting Mt - 1029/VRC	1	1	1	1
Mounting Mt - 1089/VRC	1	1	1	1
Amplifier Audio Frequency AM1780/VRC	1	1	1	1
Control C-2296	1	1	1	1
Control C-2297/VRC	1	1	1	1
Control C-2298/VRC	3	3	3	3
Cable Assy R. F. CG-1773/U (4-ft)	1	1	1	1
Cable Assy R. F. CG-1773/U (12-ft)	1	1	1	1
Cable Assy S. P. Elect CX-4722/VRC (5-ft)	1	1	1	1
Cable Assy S. P. Elect CX-4732/VRC (5-ft)	1	1	1	1
Cable Assy S. P. Elect CX-5058/VRC (9-ft)	1	1	1	1
Cable Assy S. P. Elect CX-4723/VRC (2-ft)	1	1	1	1
Cable Assy S. P. Elect CX-4723/VRC (3-ft)	1	1	1	1
Cable Assy S. P. Elect CX-4723/VRC (14-ft)	1	1	1	1
Cable Assy Power CX-4721/VRC (2 ft 6 in)	1	1	1	1
Cable Marker Kit	1	1	1	1
Mast Base AB-558 (see note)	1	1	1	1
Antenna Matching Unit MX-2799/VRC	1	1	1	1
Base, Antenna Support AB-719/VRC	1	1	1	1
Adapter UG-306B/U	1	1	1	1
Adapter UG-273/U	1	1	1	1
<b>STOWED ITEMS:</b>				
Antenna, Element, AT-1095( )/VRC	1	1	1	1
Antenna, Element, AT-1096( )/VRC	1	1	1	1
Mast Section MS-116	2	2	2	2
Mast Section MS-117	2	2	2	2
Mast Section MS-118	2	2	2	2
Antenna Tie Down Kit	2	2	2	2
Bag CX-870 (SC-D-279907)	1	1	1	1
Antenna Sleeve (Commercial Item)	1	1	1	1
Installation Instructions	1	1	1	1
<b>NOTE.</b> All M551 Vehicles are equipped with Universal Communication Harness. Mast Base AB-15/G, FSN 5985-221-5544 is substituted for Mast Base AB-558/GR when not available.				

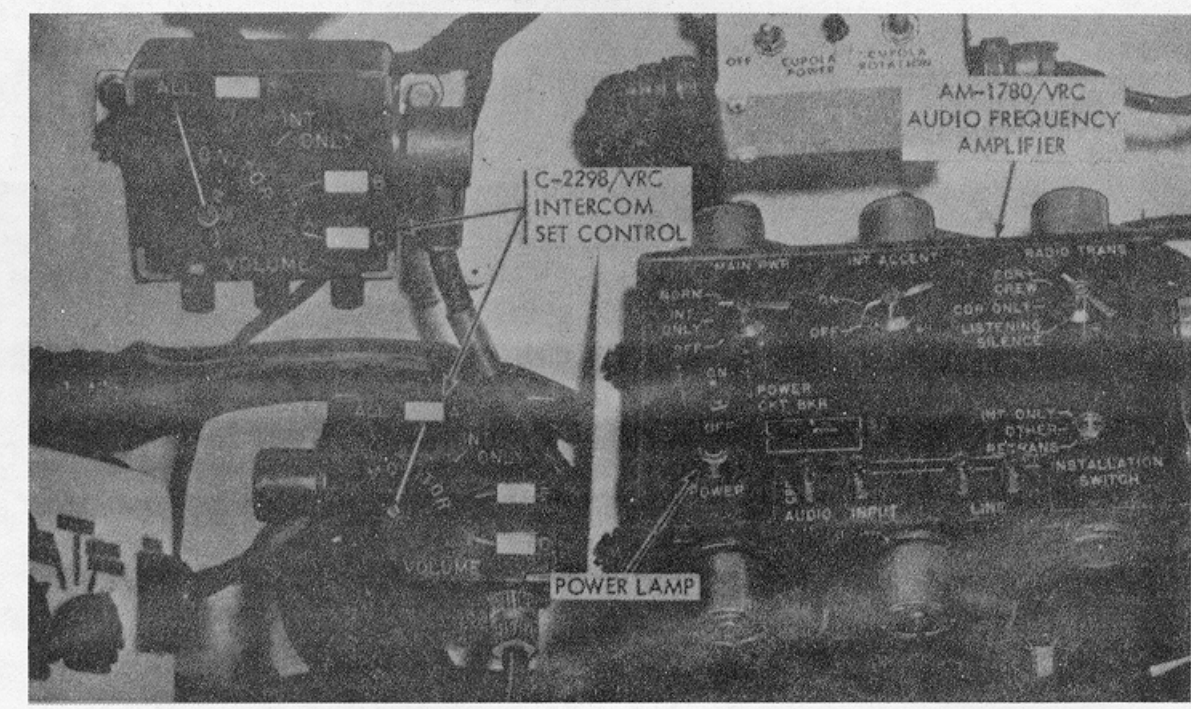

A. INTERCOM CONTROLS AND AMPLIFIER UNIT.

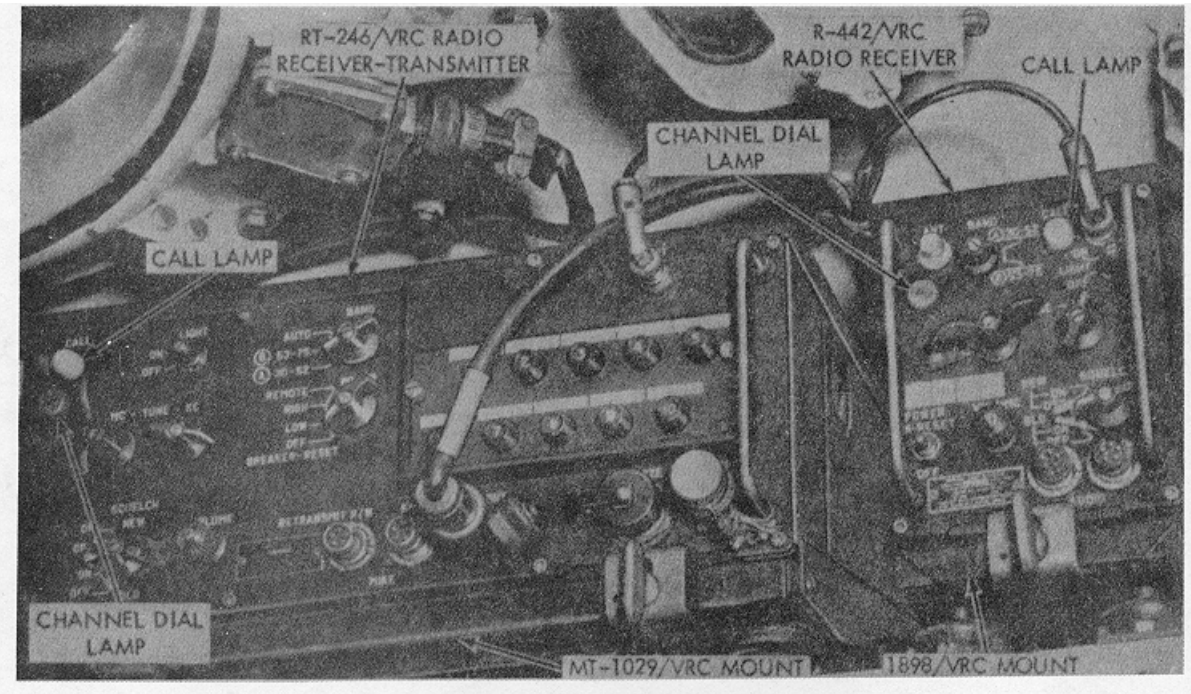

B. COMMUNICATIONS TRANSMITTER, RECEIVER, AND MOUNTS.

WE 10899

Figure 7-4. Radio set AN/VRC-12 installed

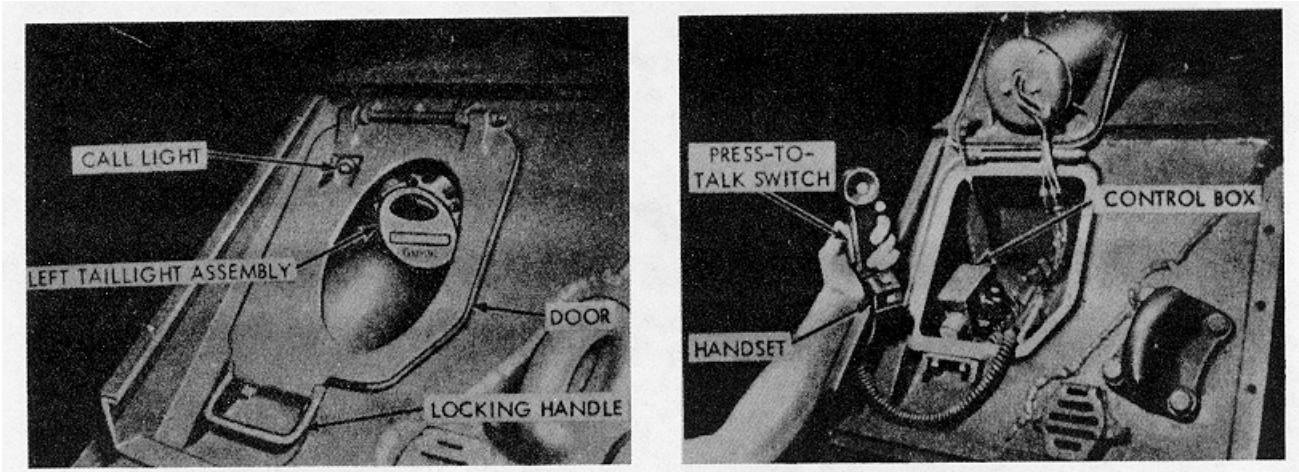

A. INTERCOMMUNICATION SET ACCESS DOOR.

B. INTERCOMMUNICATIONS SET CONTROL BOX

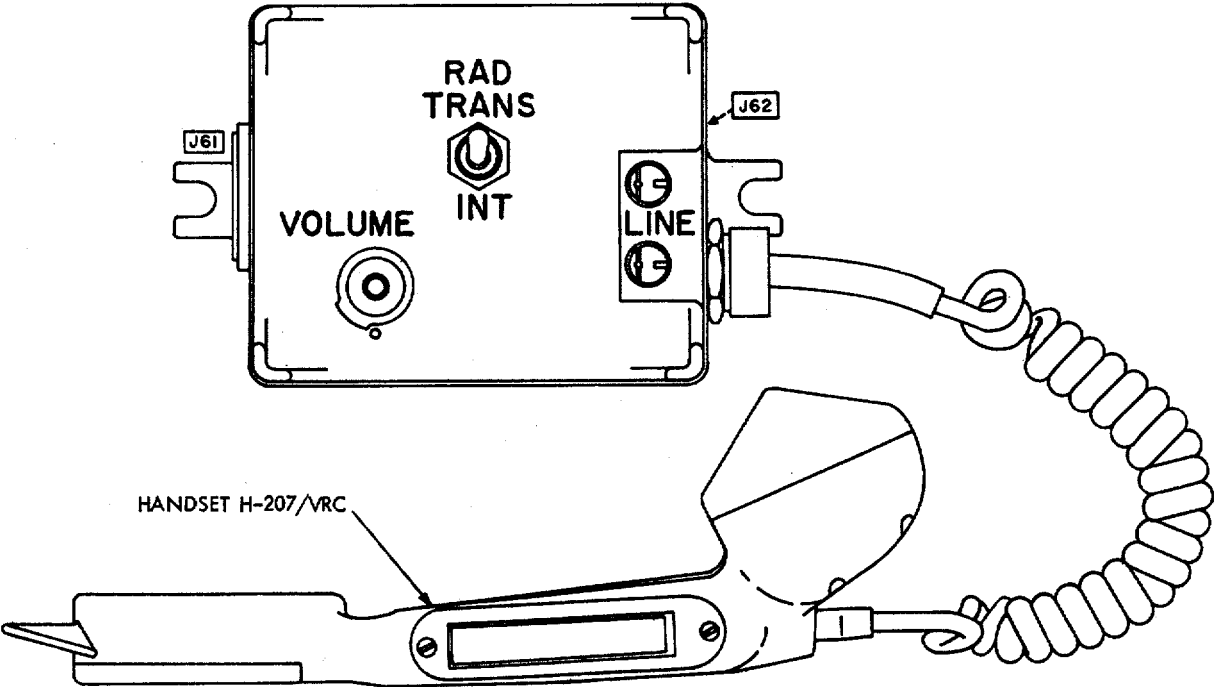

C. INTERCOMMUNICATION SET C-2296/VRC CONTROL.

WE 10881

Figure 7-5. Intercommunication set C-2296/VRC control installed

## CHAPTER 8 ORGANIZATIONAL MAINTENANCE INSTRUCTIONS

---

### Section 8-1. GENERAL

a. Chapters 8, 9, 10, and 11 contain organizational maintenance instructions for hull, power plant and turret components. When the nature of repair, modification or adjustment is beyond the scope of organizational maintenance, material will be referred to support maintenance.

b. Illustrated maintenance procedures follow one of three basic categories:

- (1) Removal/installation by numerical sequence.
- (2) Descriptive step-by-step removal/installation.
- (3) Exploded view with legend for replacement of unserviceable components as required.

c. Refer to LO 9-2350-230-12 for organizational lubrication instructions.

#### 8-2. Preventive Maintenance Services

These services are performed by organizational maintenance personnel with the assistance of the vehicle crew. The intervals and items to be checked by organizational maintenance personnel are listed under pertinent assembly or component in table 8-17.

#### 8-3. Repair Parts

a. Repair parts, tools, and equipment are available to the organizational mechanic to perform those maintenance functions allocated to organizational maintenance personnel.

b. Remove preservative material from all spare parts before installing.

#### 8-4. Special and Improvised Tools and Equipment

a. Special tools and equipment will be found in table 8-1. Standard and commonly used tools and equipment having general application to this

material are authorized for issue by tables of allowances (TA) and tables of organization and equipment (TOE).

b. An improvised tool (gage) to facilitate control cable adjustment is illustrated in figure 8-0.

#### 8-5. Painting and Restencilling Vehicle Markings

a. Painting Instructions. Preparation of the material for painting, methods of painting, and material to be used are contained in TB 746-93-1 and TM 9-213. Instructions for camouflage painting are contained in FM 5-20.

b. Restencilling Vehicle Markings. When required to insure legibility, restencil in accordance with instructions contained in table 8-2.

#### 8-6. Application of Adhesives

a. Clean surfaces to be bonded with toluol cleaner (FSN 6810-257-2486). Surface must be free of grease, paint, talc, soapstone or any other foreign substance.

b. Stir adhesives until fluid. Apply an even coat of adhesive to each mating surface. Let dry to touch. (In any event, no less than 1/2 hour -24 hours is optimum - temperature and humidity will be a controlling factor in drying time.)

c. Apply another even coat of adhesive to both previously coated surfaces. Let dry until tacky (approx. 20 min.), but no longer transfers to the finger when touched lightly.

d. Press rubber or fabric to metal or other mating surface applying pressure by using a roller or other suitable tool to insure full contact between surfaces.

**CAUTION: Do not attempt to pull or pry on either bonded surface after mating.**



TABLE 8-1. SPECIAL TOOLS AND EQUIPMENT

ITEM NO	ITEM	IDENTIFYING NUMBER	FIG. REF.	USE
<b>HULL, SUSPENSION, AND POWER PLANT</b>				
1	ADAPTER: brake spline	5120-906-1051 (8355955)	9-39	To adjust vehicle brakes.
2	ADAPTER: torsion bar puller	5120-901-6181 (10954004)	9-62	Used with PULLER 5120-313-9496 to remove and install No's. 2 and 3 torsion bars.
3	FIXTURE: track	4910-906-1053 (10955739)	9-80 9-81	Used to disconnect and connect track.
4	GAGE: pressure kit	4910-572-8612 (8356176)	8-1	Used to check transmission oil pressure.
5	GAGE: sprocket wear	5210-906-3706 (10954023)	9-72	Used to check sprocket for wear.
6	HANDLE	5120-034-0884 (10914196)		Used with removers and replacers.
7	INSTALLER: bearing cone	4910-906-1064 (10954367)	9-64	Used to install road wheel arm spindle inner bearing cone.
8	PIN: drift	5120-678-2795 (10861180)	9-80 9-81	Used to remove and install track pin.
9	PUNCH	5120-910-3738 (10954017)	9-65	Used to remove road wheel housing inner seal.
10	REGULATOR, accumulator charging	4910-766-3354	9-16	Check or recharge air box accumulator nitrogen pressure.
11	REMOVER	5120-907-0696 (10954000)	9-63 9-74	Used to remove shock absorber; with screw removed, use as torsion bar cover and anchor cover wrench.
12	REPLACER: bearing	5120-906-1062 (10954006-1)	9-73	Used with handle 5120-034-0884 to replace sprocket hub inner bearing cup.
13	REPLACER: bearing cup	5120-906-1063 (10954006-2)	9-73	Used with handle 5120-034-0884 to replace sprocket hub outer bearing cup.
14	REPLACER: oil seal	5120-906-1057 (10954007-1)	9-65 9-69 9-73	Used with handle 5120-034-0884 to replace idler hub oil seal; road wheel arm support housing outer oil seal; sprocket hub outer oil seal.

TABLE 8-1. SPECIAL TOOLS AND EQUIPMENT - CONTINUED

ITEM NO	ITEM	IDENTIFYING NUMBER	FIG. REF.	USE
<b>HULL, SUSPENSION, AND POWER PLANT - CONTINUED</b>				
15	REPLACER: oil seal	5120-906-1056 (10954007-2)	9-73	Used with handle 5120-034-0884 to replace sprocket hub inner oil seal.
16	REPLACER: oil seal	5120-906-1055 (10954007-3)	9-65	Used with handle 5120-034-0884 to replace road wheel arm support housing inner oil seal.
17	REPLACER: oil seal	5120-906-1054 (10954007-4)	9-64	Used with handle 5120-034-0884 to replace road wheel arm spindle oil seal.
18	REMOVER	5120-999-4055 11604833		Used with puller 5120-313-9496 to remove road wheel arm and torsion bar anchor.
18.1	REMOVER ASSY: road wheel spindle	11643803	9-64	Used to remove road wheel spindle.
19	REMOVER AND REPLACER	5120-906-1058 (10954003-3)	9-65 9-73	Used with handle 5120-034-0884 to remove sprocket hub inner bearing cone and oil seal; replace road wheel arm support housing inner bearing (use with thrust collar).
20	REMOVER AND REPLACER	5120-906-1059 (10954003-2)	9-65 9-69	Used with handle 5120-034-0884 to remove idler hub inner bearing cone and oil seal; replace No. 2 and 3 road wheel support housing outer bearing.
21	REMOVER AND REPLACER	5120-906-1060 (10954003-1)	9-64	Used with handle 5120-034-0884 to remove road wheel arm hub outer oil seal and bearing cone; replace road wheel arm hub inner bearing cup.
22	REMOVER AND REPLACER	5120-906-1061 (10954005)	9-64 9-73	Used with handle 5120-034-0884 to remove sprocket hub outer oil seal and bearing cone; replace road wheel arm hub outer bearing cup.
23	SLING: lifting	4910-907-8990 (10954024)	9-5	Used to remove and install power plant. (May also be used to remove and install grille and access cover.)

TABLE 8-1. SPECIAL TOOLS AND EQUIPMENT - CONTINUED

ITEM NO	ITEM	IDENTIFYING NUMBER	FIG. REF.	USE
<b>HULL, SUSPENSION, AND POWER PLANT - CONTINUED</b>				
24	WRENCH: fan pulley	5120-907-0698 (10954016)	9-32	Used to remove and install fan pulley retaining nut.
25	WRENCH: idler hub	5120-901-4282 (10954002-2)	9-69	Used to remove and install idler hub retaining nut.
26	WRENCH: spindle	5120-901-4283 (10954002-1)	9-76	Used to remove and install road wheel arm retaining nuts.
27	WRENCH: sprocket hub	5120-901-4294 (10954002-3)	9-73	Used to remove and install sprocket hub retaining nut.
<b>SPECIAL EQUIPMENT FOR OPERATING POWER PLANT OUT OF VEHICLE (FIG. 9-10)</b>				
	KIT: Consisting of items 28 through 34	11643870		
28	ADAPTER: coupling to hose	4730-921-3242	9-10	Four (4) required. Fuel inlet and return lines.
29	CABLE: ground	4910-084-0789 (10913655)	9-10	One (1) required From power plant-to-vehicle ground.
30	CABLE: power	5180-245-4280 10954635	9-10	One (1) required From generator harness-to-vehicle voltage regulator.
31	CABLE: power	4910-045-4275 10954664	9-10	One (1) required From power plant harness-to-vehicle harness.
32	COUPLING: quick disconnect	4730-738-8571 (7388571)	9-10	Two (2) required. Used with hose assembly MS 28741-8-1200.
33	HOSE: fuel	4720-803-7667 MS 28741-8-1200	9-10	Two (2) required. Fuel inlet and return lines.
34	LEAD: engine starter	2720-059-5777 C-11605661	9-10	One (1) required Main power cable-power plant starter-to-battery circuit.

TABLE 8-1. SPECIAL TOOLS AND EQUIPMENT - CONTINUED

ITEM NO	ITEM	IDENTIFYING NUMBER	FIG. REF.	USE
<b>TURRET ELECTRIC DRIVE, MISSILE, ARMAMENT, AND SIGHTING AND FIRE CONTROL</b>				
	TOOL KIT, GUN AND TURRET: supplemental, organizational maintenance	4933-921-7335 5910335		
	Consisting of:			
34.1	PROD TEST: test-electrical connector	6625-678-0657 10394564-010		Used with multimeter.
34.2	ADAPTER: socket wrench 1/2 x 3/4	5120-227-8088 GGG-W-641	11-13	Used with wrench assy. 4933-915-8560 to remove/
34.3	MULTIMETER:	6625-553-0142		install firing probe.
35	Deleted. (See ETHYL ALCOHOL, Sect. B-3 App. II)			
36	Deleted - See item 51			
37	SOCKET WRENCH ATTACHMENT SOCKET HEAD SCREW: 3/16 hex plug end size	5120-683-8597	11-13	Used to install firing probe cover and guard.
38	SOCKET WRENCH ATTACHMENT SOCKET HEADSCREW: 1/4 hex plug end size	5120-596-8508 5120-821-3441	10-26	Used with TORQUE WRENCH to remove or install optical tracker.
39	SOCKET WRENCH ATTACHMENT-SOCKET HEAD SCREW: 5/16 plug end size	5120-243-1674	10-21 10-22	Used with TORQUE WRENCH 5120-821-3441 to remove or install optical transmitter.
39.1	SOCKET WRENCH ATTACHMENT SOCKET HEAD SCREW: 3/8 hex end	5120-596-1199		
39.2	SOCKET WRENCH ATTACHMENT SOCKET HEAD SCREW: 1/2" sq dr, 3/8 hex plug end size	5120-585-6237		
40	PLIERS: slip-joint	5120-624-8065		Removing and installing electrical harness connectors as required.
40.1	PLIERS:	5120-247-5177		Use as required.
40.2	PLIERS: retaining ring (check valve)	5120-464-4777 11578314	11-10.2	Used to remove snap ring when disassembling check valve
		<b>8-5</b>		

TABLE 8-1. SPECIAL TOOLS AND EQUIPMENT

ITEM NO	ITEM	IDENTIFYING NUMBER	FIG. REF.	USE
	<b>TURRET ELECTRIC DRIVE, MISSILE, ARMAMENT, AND SIGHTING AND FIRE CONTROL-CONT.</b>			
40.3	PULLER TOOL: check valve	4933-117-9351 11578228	11-10.1	Used to remove check valve assembly from gun tube.
40.4	SCREWDRIVER: jewelers	5120-180-0728		To adjust balance potentiometer in accessory box, amplifier-integrator, and relay boxes.
40.5	ALIGNMENT TOOL:	5120-227-7291 GG-A-450		To adjust balance potentiometer in accessory box, amplifier-integrator, and relay boxes.
40.6	SOCKET, SOCKET WRENCH: 3/4 drive, 1-5/8 opening	5120-261-2823	11-13	Used to remove/install firing probe outer nut.
41	TEST SET: electrical drive	4933-909-9356 (11586473)	10-3	Used to check out turret electric drive control system.
42	Deleted			
42.1	SERVICING TOOL, CHECK VALVE:	4933-464-4776 11578313	11-10.2 11-10.3	Used to disassemble and clean check valve.
43	Deleted (See TOLUENE, Sect. B-3 App. II)			
44	Deleted			
45	WRENCH, SPANNER:	5120-915-8572 11577226	11-14	To remove and replace breech mechanism drive motor.
46	WRENCH, ASSEMBLY:	4933-915-8560 11576797	11-13	To remove and replace breech mechanism firing probe nut.
46.1	WRENCH: check valve plug	4933-111-6734 11578063	11-10.1	Used to remove/install check valve plug.
47	Deleted			
48	WRENCH, TORQUE: (0 - 350 ft-lb)	5120-242-3263	As required.	
49	WRENCH, TORQUE: (100 - 750 in. -lb)	5120-821-3441	As required.	

TABLE 8-1. SPECIAL TOOLS AND EQUIPMENT - CONTINUED

ITEM NO	ITEM	IDENTIFYING NUMBER	FIG. REF.	USE
50	Deleted			
<b>MISCELLANEOUS SPECIAL EQUIPMENT</b>				
51	RIVER: hex head (1/8")	5120-596-0934	10-21 10-22	Used with TORQUE WRENCH 5120-598-6906 to remove or install optical transmitter.

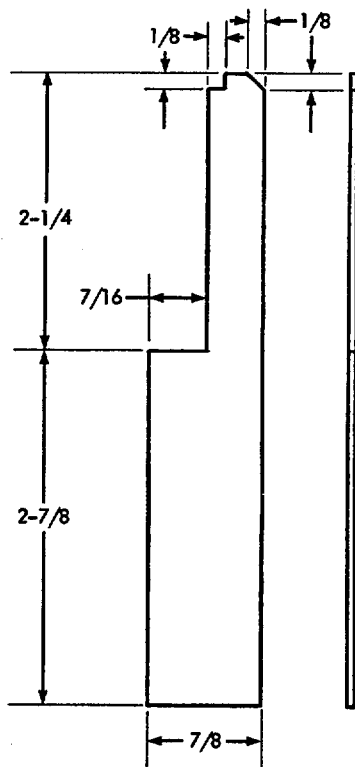

TOOL MAY BE FABRICATED FROM 1/16 OR 1/8 INCH ALUMINUM, STEEL, PLEXIGLASS, OR FIBERBOARD.

TOLERANCE ON ALL DIMENSIONS IS ± 1/32 INCH.

REFER TO FIGURES 9-53 AND 9-53.1 FOR USE OF TOOL

WE 12150

Figure 8-0. Improvised tool for adjusting land steer control cables and linkage.

8-6.1

TABLE 8-2. STENCIL LOCATIONS AND SPECIFICATIONS

STENCIL	LOCATION
	<p><b>NOTE 1.</b> <u>Stencils maybe one or more lines as space permits, with 1/4-inch spacing between lines and each letter to be 0.100 thick x 1/2 inch high.</u></p> <p><b>NOTE 2.</b> <u>Paint exterior letters white and interior letters black (SPEC-TT-E-48).</u></p>
	<p style="text-align: center;"><b>TURRET EXTERIOR</b></p> <p>Between Cal. .50 ammunition footmans loops on turret upper slope plate (6 stencils on left side and 1 on right side).</p>
WATER CAN	Between water can footman loops at front of turret ventilating fan.
	<p><b>NOTE.</b> <u>The following stencils are located on turret rear upper slope plate and are for O.E.M. equipment which is carried in turret stowage rack.</u></p>
BEDROLL	Left center portion of rack.
3 BEDROLL	Below FIELD PACK stencil.
FIELD PACK	Right center portion of stowage rack.
3 FIELD PACK	Below BEDROLL stencil.
FLAG SET	Below SPARE ANTENNA stencil.
HELMET (4)	Evenly spaced across top portion of turret stowage rack.
PAULIN	Below SPARE BARREL stencil.
RATIONS	Below 3 FIELD PACK stencil.
SPARE BARREL	Right of stowage rack center net strap and at lower portion of slope plate.
SPARE ANTENNA	Left of stowage rack center net strap and at lower portion of slope plate.
	<p style="text-align: center;"><b>TURRET INTERIOR</b></p>
AMMO 7.62MM	Left front on turret floor under ammunition box.
BINOCULARS	On front of binoculars bracket which mounts to left side of commander's sub-floor.
CANTEEN	<p>One on left front leg bracket of commander's sub-floor.</p> <p>One on vertical ammunition rack front support.</p> <p>One on rear side of 7.62-MM ammunition feed box.</p>
FLASHLIGHT	Above flashlight holder to right of commander.
GAS MASK	<p>One at left front of loader on turret lower slope plate.</p> <p>One at left front of loader on turret upper slope plate.</p>

TABLE 8-2. STENCIL LOCATIONS AND SPECIFICATIONS - CONTINUED

STENCIL	LOCATION
<b>TURRET INTERIOR - Continued</b>	
GRENADES	One above grenade bag to right of commander. One on protective screen frame above grenade bag to left of loader.
7.62-MM SPARE BARREL	On turret roof above loader.
M37 PERISCOPE	On bottom of M37 periscope rack which is mounted to left front of turret roof.
NIGHT VISION DEVICE	Above night vision device cover which mounts to turret upper slope plate - left front.
ODDMENT BOX	One on each door of oddment box located under loader's seat.
<b>HULL EXTERIOR</b>	
AXE	Above bracket which secures axe head to engine access cover.
BORE BRUSH	Rearward on battery access cover just below hinged portion of cover.
CLEANING STAFFS	Centered between two brackets which secure cleaning staffs on lower portion of engine access cover.
CROWBAR	Centered between two brackets which secure crowbar on engine access cover.
MATTOCK	Left of strap which secures mattock on engine access cover.
MATTOCK HANDLE	Between two brackets which secure mattock handle on engine access cover.
RAMMER	Forward on battery access cover just below hinged portion of cover.
SHOVEL	On bracket which secures shovel blade on engine access cover.
TOW CABLE	To right of strap which secures tow cable eyes at top center of engine access cover.



TABLE 8-2. STENCIL LOCATIONS AND SPECIFICATIONS - CONTINUED

STENCIL	LOCATION
TRACK FIXTURE	<p align="center"><b>HULL EXTERIOR - Continued</b></p> <p>Centered on battery access cover just below hinged portion of cover.</p>
	<p align="center"><b>HULL INTERIOR</b></p>
CAL .50 AKLO	On torsion bar tunnel at rear center of driver's seat.
CANTEEN	On bulkhead below canteen bracket, left rear of driver.
COOK STOVE	On bracket which secures stove to bulkhead, left rear of driver.
GASMASK	On hull upper right slope plate, to right of driver.
7.62-M4 A4MO	One on hull floor, right rear of driver in back of torsion bar tunnel. One on torsion bar tunnel, right rear of driver's seat.
PAMPHLET BAG	On hull upper right slope plate, to right of driver.
PERISCOPE AND SPARE HEAD	On periscope box attached to hull roof, right of driver.
RATIONS	On torsion bar tunnel at rear center of driver's seat.
SUBMACHINE GUN	On bracket which secures gun to hull roof, left rear of driver.
SUBMACHINE GUN AMMO	On bracket which secures ammo to hull roof, left of driver.

## Section 8-2. TROUBLESHOOTING

*NOTE. All references to M55IA1 in this section pertain to vehicles equipped with laser range finder.*

### 8-7 Scope

a. This section contains troubleshooting information and provides tests for locating and correcting some of the troubles which may develop in the vehicle, armament, or sighting and fire control materiel. Each symptom of trouble or malfunction given for an individual unit or system is followed by a list of probable causes and corrective actions necessary to remedy the malfunction.

b. If a specific trouble, test, or remedy is not covered in this manual, proceed to isolate the system in which the trouble occurs; then locate the trouble. Do not neglect the use of any test instruments such as ohmmeter, voltmeter, ammeter, multimeter, test lamp, hydrometer, or pressure and vacuum gages that are available. Standard automotive theories and principles of operation apply in troubleshooting the vehicle. Standard armament procedures apply in trouble-

shooting the armament. Question the vehicle crew to obtain the maximum number of observed symptoms. The greater the number of symptoms of trouble that can be evaluated, the easier will be the isolation of the defect.

c. Tests and remedies provided in this section are governed by the scope of organizational level of maintenance.

d. Troubleshooting information is listed in table 8-4 which gives the symptoms of troubles usually encountered, with the necessary corrective action. If the corrective action does not remedy the trouble, notify support maintenance.

e. Refer to table 10-3 for additional information on testing, malfunctions, and remedies for the turret electric drive control system.

(8-8.2 blank)/8-8.1

TABLE 8-2.1. TROUBLESHOOTING INDEX

COMPONENT	TABLE REFERENCE	COMPONENT	TABLE REFERENCE
Transmission	8-3; 16, 8-4	Turret Elec. Drive Control	82, 8-4
Engine	1, 8-4	Turret Traverse Mechanism	99, 8-4
Hull Electrical	41, 8-4	Elevating Mechanism	103, 8-4
Generating System	42, 8-4	Conventional Weapons Elect.	110, 8-4
Tracks and Suspension	46, 8-4	Missile Subsystem	115, 8-4
Personnel Heater	51, 8-4	M81 Gun-Launcher	122, 8-4
Winterization Kit	60, 8-4	Gun-Launcher Mount	131, 8-4
Bilge Pump	67, 8-4	Sighting & Fire Control	136, 8-4
Turret Elec. Accessories	72, 8-4	Ohmmeter Method of Electrical Troubleshooting	8-5
Commander's Cupola	78, 8-4		

**8-8. Engine**

a. Starting, fuel, lubrication, coolant, and oil cooling systems are all regarded as being part of the engine, and will be treated as such in this manual. Trouble in any one of these systems will be reflected in engine performance; therefore, corrective action for these troubles is contained in the engine section of the troubleshooting table.

b. When troubleshooting the engine or one of the systems mentioned in a. above, open the power plant exhaust grilles for access to components of the engine or its various systems.

c. During all tests, observe pressure and temperature warning lights on driver's indicator panel.

d. Check engine oil and water, and transmission oil levels before starting the engine. Add if necessary.

e. Warm up engine to operating temperature before conducting tests.

f. Check engine stall speed (table 8-17, sequence 64).

**8-9. Transmission**

a. Transmission Oil Level. Before making pressure tests, check transmission oil level and add oil if necessary. The cross drive transmission does not burn or use oil as an engine does. Consequently, if transmission oil level is found to be low at frequent checking periods, the cause is due to leakage.

Source of leakage must be determined and the condition corrected to avoid damage to transmission. Notify support maintenance.

**CAUTION:** Remove drive shafts (fig. 9-71) when pressure checking transmission in vehicle.

b. Pressure Check Points. To aid in troubleshooting and testing, a number of plugged openings are provided for checking operating pressures (fig. 8-1). These plugs can be removed for connection of pressure gage 4910-572-8612. Use these pressure test points to locate abnormal pressures that indicate transmission malfunctions.

**CAUTION:** Stop engine each time before re-moving or installing pipe plugs and attaching gage adapter. Install plug as soon as gage adapter is removed. Remove only the plug necessary to perform the desired test.

c. The chart in table 8-3 lists normal hydraulic pressures under various operating conditions with an engine speed of 1500 rpm or as specified in table. Small variations in pressure from those given in the chart do not necessarily mean that malfunctions exist. Malfunctions will cause radical changes in pressure. Table 8-4 will furnish probable causes of any abnormal test results.

**NOTE:** Should any of the pressure or temperature warning lights indicate malfunctions, the engine must be stopped and the cause determined.

d. Use of the intercommunication set (fig. 7-5) will facilitate communication with the driver.

TABLE 8-3. XGT-250-1A TRANSMISSION PERFORMANCE TESTS (FIG. 8-1)

NORMAL PRESSURES - NEUTRAL STEER									
Single Figures are Minimums - Two Figures Indicates Range									
Plug (Fig. 8-1)	Pressure Check Point	Input RPM	Transmission Selector Positions						
			Neutral	1st Gear	2nd Gear	3rd Gear	4th Gear	Reverse 1	Reverse 2
1	Lockup clutch (engaged)	2400	150-180	150-180	150-180	150-180	150-180	150-180	150-180
2	Right-steer clutch	1500	180	180					
3	Right-output clutch	1500			165	165	165		
4	Low clutch	1500		180	180			130	
5	Main	1500	190-215	190-210	190-210	190-210	190-210	140-175	190-210
6	Left-reverse clutch	1500						130	180
7	Right-reverse clutch	1500						130	180
8	Left-output clutch	1500			165	165	165		
9	Left-steer clutch	1500	180	180					
10	Intermediate clutch	1500				180			180
11	High clutch	1500					177		
12	Lubrication (from cooler)	1800					20-40		

  

RIGHT AND LEFT STEER PRESSURE TESTS					
Minimum Pressures at Input RPM 1500					
Direction of Steer	Plug No. (Fig. 8-1)	Land Steer			
		Neutral 1st	2nd - 3rd 4th	Reverse 1	Reverse 2
Right	4		150	130	150
Right	9	150			
Left	11		150	130	150
Left	8	150			

PITOT (GOVERNOR) RPM TESTS		
No Load - Both Output Shafts Disconnected		
	* RPM at Transmission Output	* RPM at Odometer Drive Shaft
Lockup Engages - Full TV	250-295	770-910
Lockup Releases - No TV	105-160	325-490

\* RPM may be measured at transmission output or at odometer drive flexible shaft (fig. 9-116), whichever is more convenient.

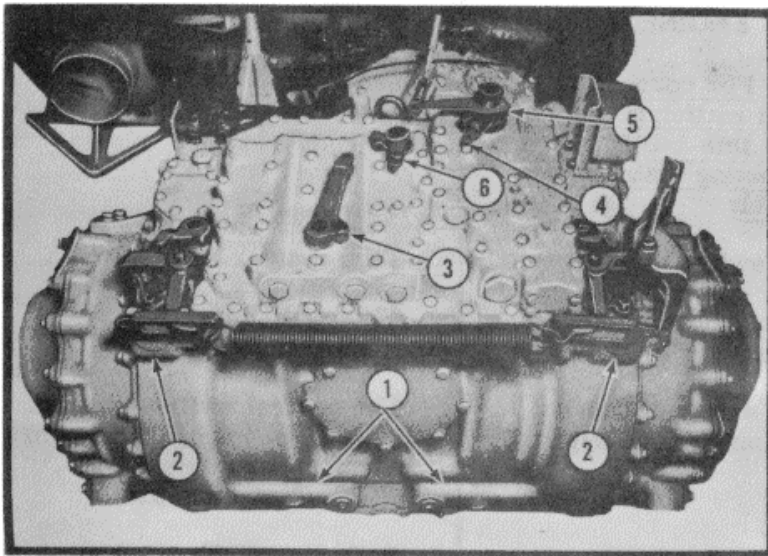

TRANSMISSION SHOWN WITH CONTROLS REMOVED FOR CLARITY

LEGEND

- 1. BRAKE COOLANT MANIFOLDS (REF.),
- 2. FOOT BRAKE LINKAGE (REF.),
- 3. STEER LEVER
- 4. SHIFT LEVER
- 5. THROTTLE LEVER
- 6. WATER STEER LEVER

CONTROLS MAY BE OPERATED FROM DRIVER'S COMPARTMENT DURING PRESSURE TESTS. USE OF INTERCOMMUNICATION SET WILL FACILITATE COMMUNICATION.

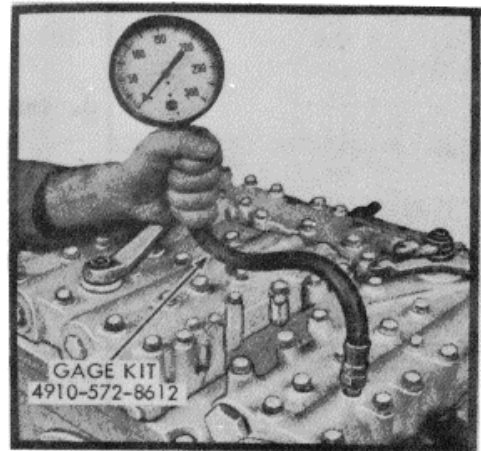

LEGEND - PRESSURE CHECK POINTS

- 1. LOCKUP CLUTCH
- 2. RIGHT-STEER CLUTCH
- 3. RIGHT-OUTPUT CLUTCH
- 4. LOW CLUTCH
- 5. MAIN
- 6. LEFT-REVERSE CLUTCH
- 7. RIGHT-REVERSE CLUTCH
- 8. LEFT-OUTPUT CLUTCH
- 9. LEFT-STEER CLUTCH
- 10. INTERMEDIATE CLUTCH
- 11. HIGH CLUTCH
- 12. LUBRICATION (FROM COOLER)

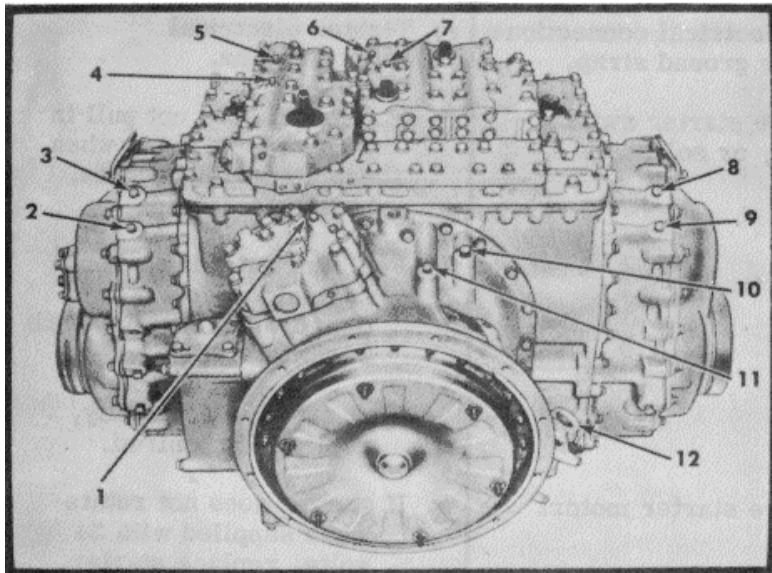

REFER TO PARAGRAPH 8-9 BEFORE STARTING PRESSURE TESTS.

WE 66619

WE 666191

Figure 8-1. XTG250-1A transmission oil pressure check points - locational reference



Table 8-3. TROUBLESHOOTING - CONTINUED

Malfunction	Probable cause	Corrective action
<b>ENGINE - Continued</b>		
<p>3. Engine will not rotate - Continued</p>	<p><u>b.</u> Internal seizure</p>	<p><u>b.</u> Notify support maintenance.</p>
<p>4. Low engine crank speed</p>	<p><u>a.</u> Low battery voltage vehicle.</p>	<p><u>a.</u> Replace batteries or slave</p>
	<p><u>b.</u> Loose or corroded battery cable terminals or electrical connections</p>	<p><u>b.</u> Clean and tighten battery cable terminals and electrical connections.</p>
	<p><u>c.</u> Incorrect oil viscosity for prevailing temperature</p>	<p><u>c.</u> Consult LO 9-2350-230-12 for proper grade of oil.</p>
<p>5. Engine cranks but fails to start</p>	<p><u>a.</u> Check fuel tanks, add fuel if required.</p>	
	<p><u>b.</u> Fuel shut-off control is closed.</p>	<p><u>b.</u> Open fuel shut-off.</p>
	<p><u>c.</u> Fuel shut-off valves on fuel tanks are closed.</p>	<p><u>c.</u> Open fuel tank valves.</p>
	<p><u>d.</u> Main fuel line disconnected</p>	<p><u>d.</u> Connect fuel line,</p>
	<p><u>e.</u> Fuel injector racks not in full fuel position due to defective injector or bind in control linkage.</p>	<p><u>e.</u> Refer to support maintenance.</p>
	<p><u>f.</u> Defective engine fuel pump</p>	<p><u>f.</u> Replace fuel pump (fig. 9-19).</p>
	<p><u>g.</u> Restriction in air inlet</p>	<p><u>g.</u> Remove restriction.</p>
	<p><u>h.</u> Defective engine air blower drive.</p>	<p><u>h.</u> Notify support maintenance.</p>
	<p><u>i.</u> Low engine compression gaskets defective. Notify support maintenance.</p>	<p><u>i.</u> Exhaust valves, rings, or</p>
	<p><u>j.</u> Air in fuel system and tighten.</p>	<p><u>j.</u> Check fuel lines for leaks</p>
<p>6. Engine fails to start in low ambient temperature.</p>	<p><u>a.</u> Low engine crank speed be at least 100 rpm.</p>	<p><u>a.</u> Engine crank speed should</p>
	<p><u>b.</u> Battery power low</p>	<p><u>b.</u> Replace batteries or slave vehicle.</p>
	<p><u>c.</u> Improper oil viscosity for prevailing temperature.</p>	<p><u>c.</u> Refer LO 9-2350-230-12.</p>

Table 8-3. TROUBLESHOOTING - CONTINUED

Malfunction	Probable cause	Corrective action
<p>6. Engine fails to start in low ambient temperature - Continued</p>	<p style="text-align: center;"><b>ENGINE - Continued</b></p> <p><u>d.</u> Air box heater inoperative</p> <p><u>e.</u> Accumulator defective 9-15).</p> <p><u>f.</u> Hand pump will not develop sufficient pressure to charge accumulator.</p> <p><u>g.</u> Damaged high tension lead damaged, replace.</p> <p><u>h.</u> Defective ignition coil</p> <p><u>i.</u> Improper grade of fuel</p> <p><u>j.</u> Improper start procedure</p> <p><u>k.</u> Winterization kit inoperative.</p>	<p><u>d.</u> Check accumulator pressure. Recharge accumulator with hand pump if fuel pressure gage is not in cold start band.</p> <p><u>e.</u> Replace accumulator (fig. 9-15).</p> <p><u>f.</u> Inspect, repair, or replace pump.</p> <p><u>g.</u> If high tension lead is cut or</p> <p><u>h.</u> Replace ignition coil.</p> <p><u>i.</u> Consult fuel specification (par. 1-6) for proper grade of fuel,</p> <p><u>j.</u> Consult cold weather start procedure (fig. 2-14). Proper starting is a result of experience and development of a "feel" for cold starting.</p> <p><u>k.</u> Consult troubleshooting procedure for winterization kit (later in this table).</p>
<p>7. Lack of engine power</p>	<p><u>a.</u> Improper control linkage adjustment,</p> <p><u>b.</u> Insufficient fuel</p>	<p><u>a.</u> Determine full engine and transmission throttle control lever travel, Adjust linkage (fig. 9-44).</p> <p><u>b.</u> Fuel supply low or shut-off valve closed. Add fuel or open shut-off valves.</p> <p>Inspect fuel strainer and filter for water, foreign matter, or damage.</p> <p>Clean, repair, or replace as required.</p> <p>Measure fuel return flow (par. 9-9).</p>



Table 8-3. TROUBLESHOOTING - CONTINUED

Malfunction	Probable cause	Corrective action
<p>7. Lack of engine power - Continued</p> <p>8. Uneven operation, frequent stalling, or rough idle</p> <p>9. Pre-detonation,</p>	<p style="text-align: center;"><b>ENGINE - Continued</b></p> <p><u>c.</u> Insufficient air</p> <p><u>a.</u> Low coolant temperature</p> <p><u>b.</u> Insufficient fuel</p> <p><u>c.</u> Faulty injectors</p> <p><u>d.</u> Governor instability</p> <p><u>a.</u> Oil in combustion air stream.</p> <p><u>b.</u> Faulty injectors</p>	<p><u>c.</u> Check air cleaner indicator for restriction (fig. 5-1) and clean or replace element as required,</p> <p>Check the turbocharger and engine blower for foreign object damage and proper operation. If defective, notify support maintenance.</p> <p><u>a.</u> if engine coolant temperature is not between 1600F and 210F, troubleshoot coolant system.</p> <p><u>b.</u> Check fuel return flow (par. 9-9).</p> <p><u>c.</u> Erratic engine operation may be caused by leaking fuel injector spray tips. Notify support maintenance.</p> <p><u>d.</u> Hunting may be caused by bind in the governor-to-injector linkage. Notify support maintenance.</p> <p>Buffer in governor out of adjustment. Notify support maintenance.</p> <p><u>a.</u> Check the engine for blocked air box drains (fig. 9-13).</p> <p>Inspect for excessive oil in the air inlet. Cause may be due to oil leak at turbocharger or blower-to-block gasket. Notify support maintenance.</p> <p><u>b.</u> Notify support maintenance.</p>

Table 8-3. TROUBLESHOOTING - CONTINUED

Malfunction	Probable cause	Corrective action
<p>10. Engine overheats</p>	<p style="text-align: center;"><b>ENGINE - Continued</b></p> <p>a. Restricted cooling air passages</p> <p>b. Low coolant level</p> <p>c. Improper coolant fan operation</p> <p>d. Pressure cap defective</p> <p>e. Thermostat inoperative</p> <p>f. Coolant pump drive belt slipping</p> <p>g. Coolant pump failure damaged impeller.</p> <p>h. Malfunction of lubrication system</p>	<p>a. The exterior of the radiator core may be plugged, restricting normal air flow. Clean radiator with air, water, or steam.</p> <p>b. Check coolant level and fill as required. If abnormal amount of water is required to fill the coolant system, inspect for loose connections or source for leakage. Notify support maintenance if cause is other than the coolant system.</p> <p>c. Check the coolant fan drive belts for proper tension. Adjust as required.</p> <p>If fan does not operate with a coolant temperature of 185°F, lock up clutch (fig. 5-2) and notify support maintenance.</p> <p>d. Replace cap.</p> <p>e. The thermostat may be defective and not open at normal operation temperature. Remove and test in hot water bath (167-192°F). If defective, replace.</p> <p>f. Tighten or replace belt (Fig. 9-36).</p> <p>g. Inspect the coolant pump for If defective, replace (Fig. 9-36).</p> <p>h. The oil filter may be clogged causing a restriction in circulation of lubricant. Inspect filter. Check oil level in accordance with LO 9-2350-230-12. If oil level drops continually, notify support maintenance.</p>

Table 8-3. TROUBLESHOOTING - CONTINUED

Malfunction	Probable cause	Corrective action
11. High oil consumption	<p style="text-align: center;"><b>ENGINE - Continued</b></p> <p><u>a.</u> External leakage</p> <p><u>b.</u> Internal leakage</p> <p><u>c.</u> Breather restriction</p> <p><u>d.</u> High crankcase pressure</p>	<p><u>a.</u> Inspect oil filter, hose connections, and valve cover gasket for leakage. Tighten or replace as required.</p> <p><u>b.</u> Remove air inlet elbow and inspect turbocharger for evidence of oil. Notify support maintenance personnel if internal leakage exists.</p> <p><u>c.</u> Clean and repair or replace crankcase breather assembly (fig. 9-13).</p> <p><u>d.</u> Clean engine breather air box collector drain and inspect for restriction.</p>
12. Low oil pressure	<p><u>e.</u> Internal engine damage</p> <p><u>a.</u> Pressure indicator inoperative</p> <p><u>b.</u> Oil quantity may be low</p> <p><u>c.</u> Improper oil for prevailing temperature</p> <p><u>d.</u> Poor oil circulation</p>	<p><u>e.</u> Notify support maintenance.</p> <p><u>a.</u> Check for loose electrical connections at transmitter and gage.</p> <p>Check oil pressure with positive pressure gage and replace transmitter if faulty.</p> <p><u>b.</u> Fill to proper level in accordance with LO 9-2350-230-12.</p> <p><u>c.</u> Consult LO 9-2350-230-12 for proper grade of oil.</p> <p><u>d.</u> Replace oil filter element if clogged. A plugged oil cooler is indicated by high oil temperature.</p>
13. Black or gray exhaust a. smoke	<p><u>a.</u> Incomplete combustion</p>	<p><u>a.</u> Exhaust back pressure or restricted air inlet causes insufficient combustion air. Locate and clear the obstruction.</p> <p>Check for obstruction in exhaust duct or muffler.</p>

Table 8-3. TROUBLESHOOTING - CONTINUED

Malfunction	Probable cause	Corrective action
13. Black or gray exhaust smoke - Continued	<p style="text-align: center;"><b>ENGINE - Continued</b></p> <p><u>a.</u> Incomplete combustion - Continued</p> <p><u>b.</u> Excessive fuel or irregular fuel distribution.</p> <p><u>c.</u> Improper grade of fuel grade (par. 1-6).</p>	<p>Check turbocharger for foreign object damage and free spin. Notify support maintenance if turbocharger is defective.</p> <p>Check air inlet for obstruction.</p> <p><u>b.</u> Notify support maintenance.</p> <p><u>c.</u> Check fuel supply for proper</p> <p>NOTE: Engine exhaust will tend to be blacker when using CITE fuel than with standard grades of fuel.</p>
14. Blue exhaust smoke	<p><u>a.</u> Condensation in fuel</p> <p><u>b.</u> Low coolant temperature</p> <p><u>c.</u> Lubrication oil not burned in cylinder (blown through cylinder during scavenging period)</p> <p><u>d.</u> Engine breather drain collector box needs draining.</p>	<p><u>a.</u> Drain condensate from filters Wig. 5-2) and center fuel tank (fig. 5-3).</p> <p><u>b.</u> Blue smoke should clear up after coolant temperature reaches a minimum of 160°F.</p> <p><u>c.</u> Internal lubrication oil leaks present. Consult high oil consumption (above). Notify support maintenance. Drain (Fig. 5-3).</p>
15. White exhaust smoke	<p>Misfiring cylinders</p>	<p>Notify support maintenance.</p>
<b>TRANSMISSION</b>		
16. Vehicle will not move in any range	<p><u>a.</u> Shift control linkage disconnected, bent, broken or out of adjustment.</p> <p><u>b.</u> Low transmission oil level</p> <p><u>c.</u> Low main oil pressure</p>	<p><u>a.</u> Inspect and repair or adjust (fig. 9-47).</p> <p><u>b.</u> Consult LO 9-2350-230-12 for proper oil level.</p> <p><u>c.</u> Check for proper main oil system pressure (ar. 8-9).</p>

Table 8-3. TROUBLESHOOTING - CONTINUED

Malfunction	Probable cause	Corrective action
17. Vehicle will travel in only one range regardless of the range selected.	<p align="center"><b>TRANSMISSION - Continued</b></p> Shift control linkage faulty	Inspect and repair or adjust shift control linkage (fig. 9-47).
18. Oil high-temperature warning light comes on during normal operation	<u>a.</u> Temperature indicator faulty.  <u>b.</u> Low oil level  <u>c.</u> High oil level  <u>d.</u> Brakes improperly adjusted <u>e.</u> Oil cooler clogged	<u>a.</u> Check for loose electrical connections or replace.  <u>b.</u> Check oil level on dipstick-type gage (LO 9-2350-230-12). Fill as required. <u>c.</u> Check oil level on dipstick-type gage (LO 9-2350-230-12). Drain to proper level. <u>d.</u> Readjust brakes (fig. 9-39). <u>e.</u> Remove and steam-clean oil cooler.
19. Low lubrication pressure warning light comes on during normal operation	<u>a.</u> Pressure indicator inoperative  <u>b.</u> Low oil level  <u>c.</u> Regulator valve open or faulty.	<u>a.</u> Check for loose electrical connections, or replace transmitter if faulty.  <u>b.</u> Check oil level (LO 9-2350-230-12). <u>c.</u> Notify support maintenance.
20. Vehicle will travel in all ranges except fourth gear.	High-range clutch failed	Notify support maintenance.
21. Vehicle will travel in all ranges except reverse.	Reverse range clutch failed	Notify support maintenance.
22. Shift control selector will not move	<u>a.</u> Shift control linkage disconnected, bent, broken, or out of adjustment. <u>b.</u> Downshift inhibitor faulty <u>c.</u> Selector valve faulty	<u>a.</u> Inspect and repair or adjust (fig. 9-47).  <u>b.</u> Notify support maintenance. <u>c.</u> Notify support maintenance.

Table 8-3. TROUBLESHOOTING - CONTINUED

Malfunction	Probable cause	Corrective action
23. Steer control will not move	<p><b>TRANSMISSION - Continued</b></p> <p><u>a.</u> Steer control linkage binding, bent, or incorrectly adjusted.</p>	<p><u>a.</u> Inspect and repair or adjust (fig. 9-53).</p>
24. Converter lockup clutch will not release.	<p><u>b.</u> Steer valve faulty The lockup clutch failed</p>	<p><u>b.</u> Notify support maintenance. Notify support maintenance.</p>
25. Converter lockup clutch will not engage	<p>Low governor pressure</p>	<p>Check piton governor pressure (par. 8-9). Notify support maintenance.</p>
26. Converter lockup clutch does not engage and release at proper speeds	<p><u>a.</u> Linkage out of adjustment</p> <p><u>b.</u> Low governor pressure</p>	<p><u>a.</u> Adjust throttle control linkage (fig. 9-44).</p> <p><u>b.</u> Check piton governor pressure (par. 8-9). If incorrect, notify support maintenance.</p>
27. Brakes are hard to operate and do not stop vehicle effectively	<p><u>a.</u> Linkage out of adjustment</p> <p><u>b.</u> Brake control cable length incorrect</p> <p><u>c.</u> Bind on brake apply lever</p> <p><u>d.</u> Brake clutch not adjusted properly</p>	<p><u>a.</u> Adjust brake linkage (fig. 9-48).</p> <p><u>b.</u> Adjust brake control cable (fig. 9-48).</p> <p><u>c.</u> Eliminate bind on brake-apply lever.</p> <p><u>d.</u> Adjust brake clutch (fig. 9-39).</p>
28. Vehicle travels in first reverse range, first and second forward range, but stalls in any other range. Vehicle moves in neutral.	<p>Low-range clutch failed (will not release).</p>	<p>Notify support maintenance.</p>
29. Vehicle travels in third forward range and second reverse, but stalls in any other range. Vehicle moves in neutral.	<p>Intermediate-range clutch failed (will not release).</p>	<p>Notify support maintenance.</p>

Table 8-3. TROUBLESHOOTING - CONTINUED

Malfunction	Probable cause	Corrective action
30. Vehicle travels in fourth range but stalls in any other range. Vehicle moves in neutral.	<p align="center"><b>TRANSMISSION - Continued</b></p> High-range clutch failed (will not release).	Notify support maintenance.
31. Vehicle travels in first range but stalls in all other ranges. Vehicle is free in neutral.	<u>a.</u> Right-steer clutch failed <u>b.</u> Left-steer clutch failed	<u>a.</u> Notify support maintenance. <u>b.</u> Notify support maintenance.
32. Vehicle travels in second, third, and fourth range, but stalls in first range and reverse ranges. Vehicle does not move in neutral.	<u>a.</u> Left-output clutch faulty <u>b.</u> Right-output clutch faulty	<u>a.</u> Notify support maintenance. <u>b.</u> Notify support maintenance.
33. Vehicle travels in reverse ranges but stalls out in forward ranges. Vehicle does not move in neutral.	<u>a.</u> Left-reverse-range clutch faulty. <u>b.</u> Right-reverse-range clutch faulty.	<u>a.</u> Notify support maintenance. <u>b.</u> Notify support maintenance.
34. Vehicle has only land steer.	Steer relay valve faulty	Notify support maintenance.
35. Vehicle has only water steer.	Steer relay valve faulty	Notify support maintenance.
36. Vehicle pulls to left or right in first range. No steer applied	<u>a.</u> Steer clutch faulty <u>b.</u> Piston seal ring leakage (par. 8-9).	<u>a.</u> Notify support maintenance. <u>b.</u> Check steer clutch pressure
37. Vehicle pulls to left or right in second, third and fourth ranges. No steer applied.	<u>a.</u> Output-clutch seal ring leak (par. 8-9). <u>b.</u> Output-clutch faulty	<u>a.</u> Check output clutch pressure <u>b.</u> Notify support maintenance.
38. Vehicle pulls to left or right in reverse range. No steer applied	<u>a.</u> Reverse-range clutch seal ring leak <u>b.</u> Reverse-range clutch faulty.	<u>a.</u> Check reverse-range clutch pressure (par. 8-9). <u>b.</u> Notify support maintenance.

Table 8-3. TROUBLESHOOTING - CONTINUED

Malfunction	Probable cause	Corrective action
<p>39. Vehicle pulls to right or left in every range. applied</p> <p>40. Engine races while vehicle moves slowly.</p>	<p><b>TRANSMISSION - Continued</b></p> <p><u>a.</u> Steer linkage out of adjustment No steer</p> <p><u>b.</u> Improper track adjustment</p> <p><u>a.</u> Low main oil pressure (par. 8-9).</p> <p><u>b.</u> Low-range clutch faulty</p> <p>c. Intermediate clutch faulty</p> <p>d. High-range clutch faulty</p>	<p><u>a.</u> Adjust steer linkage (fig. 9-53).</p> <p><u>b.</u> Adjust track tension fig. 5-4).</p> <p><u>a.</u> Check main oil pressure</p> <p><u>b.</u> Check clutch pressure (par. 8-9).</p> <p>c. Check clutch pressure (par. 8-9).</p> <p>d. Check clutch pressure (par. 8-9).</p>
<p>41. No battery power</p>	<p><b>HULL ELECTRICAL SYSTEM</b></p> <p><u>a.</u> Master relay not closed,</p> <p><u>b.</u> Batteries have low voltage or are discharged</p> <p><u>c.</u> Voltage generating system faulty.</p>	<p><u>a.</u> Inspect and tighten any loose cable connections and/or ground straps on the batteries and master relay. (Table 8-6).</p> <p>The batteries may be discharged. Replace the batteries or slave vehicle and start engine. If master relay will not close, check master switch.</p> <p>Master relay faulty. Replace.</p> <p><u>b.</u> Test and service or replace batteries If properly charged batteries are not available, slave vehicle and start engine and recharge batteries with vehicle generating system.</p> <p><u>c.</u> Troubleshoot (items 42 through 43, and table 8-7).</p>



Table 8-3. TROUBLESHOOTING - CONTINUED

Malfunction	Probable cause	Corrective action
<p>42. Generating system inoperative (voltage, measured at batteries, below 26.0 volts with engine operating and all accessories off).</p> <p>42. 1. Voltage measured at batteries is above 26 volts but not in accordance with table in figure 9-110 (with engine running and all accessories off).</p> <p>42. 2. Generator "Motors" engine on shut-down</p> <p><b>NOTE</b> <u>If generator drive belts are broken, generator will motor until battery-to-regulator circuit is opened. This is normal unless motoring resumes when batteries are reconnected.</u></p>	<p align="center"><b>HULL ELECTRICAL SYSTEM - Continued</b></p> <p>a. Loose cable connectors, or improper connections</p> <p>b. Defective generator-to-voltage regulator harness</p> <p>c. Defective generator drive belts, pulleys, gear box, or tensioner</p> <p>d. Failsafe circuit in voltage regulator locked out,</p> <p>e. Loss of generator residual magnetism.</p> <p>f. Regulator faulty</p> <p>g. Generator faulty</p> <p>Voltage regulator out of adjustment</p> <p>a. Engine fuel shutoff out of adjustment</p> <p>b. Voltage regulator faulty</p>	<p>a. Inspect and tighten loose cable connectors.</p> <p>b. Check harness continuity and resistance (Table 8-7 and fig. 9-112.1).</p> <p>c. Check generator drive components (figs. 9-109, 9-111, 9-112).</p> <p>d. See voltage regulator fail safe circuit, ( table 8-7).</p> <p>e. Polarize generator (fig. 9-111:</p> <p>f. Check generator (table 8-7). Replace regulator if no fault can be found in generator, cables, or in a through e above.</p> <p>g. Generator may pass ohmeter test and still be faulty. If regulator is known to be good, replace generator.</p> <p>Adjust voltage regulator (fig. 9-110).</p> <p>a. Disconnect battery-to-voltage regulator harness. If engine continues to run, problem is in fuel shutoff system (fig. 9-23).</p> <p>b. If engine stops when battery-to-regulator harness is disconnected, voltage regulator is faulty. Check for fused relay in voltage regulator (Table 8-7). If relay is fused, check entire vehicle and correct short circuit which caused relay to fuse.</p>
<p>8-23</p>		

Table 8-3. TROUBLESHOOTING - CONTINUED

Malfunction	Probable cause	Corrective action
<p>43. Battery requires excessive amount of water added.</p> <p>44. Tachometer inoperative</p> <p>45. Speedometer inoperative</p> <p>45.1 Odometer inoperative</p>	<p><b>HULL ELECTRICAL SYSTEM - Continued</b></p> <p>Generator output voltage too high</p>	<p>Adjust voltage regulator (fig. 9-110).</p> <p>Refer to figure 8-13.1 and paragraph 8-9. 1.</p> <p>Refer to figure 8-13.1 and paragraph 8-9. 1o</p> <p>Refer to figure 8-13.1 and paragraph 8-9. 1.</p>
<p><b>TRACKS AND SUSPENSION</b></p>		
<p>46. Vehicle will not move in any transmission shift selector position.</p>	<p>Broken final drive shaft</p>	<p>Check and replace broken parts (fig. 9-71).</p>
<p>47. Vehicle pulls to one side</p>	<p>a. Unequal track tension</p> <p>b. Worn or distorted track drive sprocket or tracks</p> <p>c. Incorrect brake linkage adjustment.</p> <p>d. Incorrect brake adjustment</p> <p>e. Damaged road wheel bearings</p>	<p>a. Adjust track tension (fig. 5-4).</p> <p>b. Replace worn parts (fig. 9-72).</p> <p>c. Adjust linkage (fig. 9-48).</p> <p>d. Adjust brakes (fig. 9-39).</p> <p>e. Replace bearings (fig. 9-64).</p>
<p>48. Vehicle throws track</p>	<p>a. Improper driving or operation of vehicle</p> <p>b. Excessively loose or worn track</p>	<p>a. Review driver's instructions and proper driving methods. Do not make high speed turns.</p> <p>b. Adjust track tension (fig. 5-4), or replace worn track (fig. 9-81).</p>
<p>49. Vehicle sags to one side or rides excessively hard.</p>	<p>a. Torsion bar broken</p> <p>b. Track tension incorrect</p> <p>c. Suspension arm bearing faulty</p> <p>d. Defective shock absorbers</p>	<p>a. Replace torsion bar (fig. 9-62).</p> <p>b. Adjust track tension (fig. 5-4).</p> <p>c. Replace suspension arm housing (figs. 9-65, 66).</p> <p>d. Replace shock absorbers (fig. 9-74).</p>

Table 8-3. TROUBLESHOOTING - CONTINUED

Malfunction	Probable cause	Corrective action
<p>49. Vehicle sags to one side or rides excessively hard - Continued</p> <p>50. Excessive noise in tracks and suspension during vehicle operation</p>	<p style="text-align: center;"><b>TRACKS AND SUSPENSION - Continued</b></p> <p><u>e.</u> Incorrect installation of torsion bars and anchors</p> <p><u>a.</u> Worn or seized road wheel or idler wheel hub bearings</p> <p><u>b.</u> Worn sprockets</p>	<p><u>e.</u> Install bars and anchors correctly (fig. 9-60).</p> <p><u>a.</u> Immediately after operating vehicle, check road wheel and idler wheel hubs for excessive heat. Inspect and replace road wheel or idler wheel hub bearings as necessary (figs. 9-64 and 9-69).</p> <p><u>b.</u> Reverse sprockets or replace (fig. 9-72).</p>
<p>51. Heater will not start</p>	<p style="text-align: center;"><b>PERSONNEL HEATER</b></p> <p><u>a.</u> Improper starting procedure</p> <p><u>b.</u> No electrical power</p> <p><u>c.</u> Inlet or exhaust restriction</p> <p><u>d.</u> Insufficient fuel</p> <p>(1) Shutoff valve closed</p> <p>(2) Clogged filter in line or pump</p> <p>(3) No electrical power to pump</p> <p>(4) Defective pump</p> <p>(5) Overheat switch open</p> <p>(6) Defective shutoff solenoid,</p>	<p><u>a.</u> See figure 2-17 for proper starting procedure.</p> <p><u>b.</u> Check lead #561, control box lead, and circuit breaker (table 8-14). Repair or replace defective components.</p> <p><u>c.</u> Remove obstruction.</p> <p><u>d.</u></p> <p>(1) Open valve (fig. 9-132).</p> <p>(2) Clean or replace filter(s) (fig. 9-133, 134).</p> <p>(3) With switch in start position, check voltage at pump. If no power, check control box start switch and circuit #563A (table 8-14). Replace switch if defective (fig. 9-107). Repair harness or notify support maintenance.</p> <p>(4) If pump has power but will not run, replace pump (fig. 9-133).</p> <p>(5) Check switch (table 8-14). Replace if defective (fig. 9-137).</p> <p>(6) Check shutoff solenoid (table 8-14). If solenoid is defective, replace heater</p>

Table 8-3. TROUBLESHOOTING - CONTINUED

Malfunction	Probable cause	Corrective action
<p>52. Heater starts but indicator light will not come on.</p> <p>53. Heater overheats and shuts off</p> <p>54. Heater overheats and continues to run switch heating.</p>	<p style="text-align: center;"><b>PERSONNEL HEATER - Continued</b></p> <p><u>e.</u> Flame detector switch out of adjustment or defective</p> <p><u>f.</u> Blower motor inoperative. (1) No electrical power to  (2) Defective motor  Defective igniter or igniter resistor</p> <p><u>h.</u> Other causes</p> <p><u>a.</u> Lamp burned out</p> <p><u>b.</u> Open electrical circuit</p> <p><u>c.</u> Flame detector switch out of adjustment or defective</p> <p><u>a.</u> Restriction in air flow</p> <p><u>b.</u> Blower motor defective</p> <p><u>c.</u> Excessive fuel flow (defective fuel control valve)</p> <p>Same causes as 53 above, plug defective overheat correct cause of over-</p>	<p><u>e.</u> Check switch (table 8-14). Adjust or replace switch as necessary (fig. 9-137).</p> <p>(1) Check lead #562 (table 8-14), motor Repair harness or notify Support Maintenance.</p> <p>(2) If motor has power but will not run, replace heater.</p> <p><u>g.</u> Check igniter and resistors (table 8-14). Replace igniter if defective (fig. 9-137). If resistor is defective replace heater.</p> <p><u>h.</u> After eliminating causes "a" through "g", replace heater</p> <p><u>a.</u> Press to test. Replace lamp if burned out.</p> <p><u>b.</u> Check circuits #564 and 565 (table 8-14). Repair harness or notify Support Maintenance.</p> <p><u>c.</u> After heater has run 3 to 4 minutes, check voltage at P9, fig. 8-11. If no power, adjust or replace switch (fig. 9-137).</p> <p><u>a.</u> Remove obstruction from inlet and/or outlet.</p> <p><u>b.</u> Replace heater.</p> <p><u>c.</u> (Usually accompanied by excessive smoke). Replace heater. Replace overheat switch. Refer to 53 above to</p>

Table 8-3. TROUBLESHOOTING - CONTINUED

Malfunction	Probable cause	Corrective action
<p>55. Heater starts and runs, but stops after a short interval. (Control box switch in RUN position)</p> <p>56. Odor of fuel in ventilating air stream.</p> <p>57. Blower will not stop after purge cycle</p> <p>58. Heat output too low</p> <p>59. Heater smokes excessively or "bangs" on</p>	<p style="text-align: center;"><b>PERSONNEL HEATER - Continued</b></p> <p><u>a.</u> Clogged filter in line or pump</p> <p><u>b.</u> Flame detector switch out of adjustment or defective adjust or replace flame detector switch (fig. 9-137)</p> <p><u>c.</u> Overheat switch out of calibration heater shuts itself off. If no power and heater is not overheated replace switch fig. 9-137).</p> <p>Fuel leak at standpipe</p> <p>Flame detector switch defective.</p> <p><u>a.</u> HI-LO switch on LO</p> <p><u>b.</u> Clogged filter in line or pump</p> <p><u>c.</u> Defective fuel control valve or air valve</p> <p><u>a.</u> Fuel accumulation due to slow starting (defective igniter starting or resistor)</p> <p><u>b.</u> Excessive fuel flow (defective fuel control valve).</p>	<p><u>a.</u> Clean or replace filter(s) fig. 9-133, 134).</p> <p><u>b.</u> If indicator lamp goes out when heater shuts itself off</p> <p><u>c.</u> Check voltage at terminal 30, Fig. 8-11 immediately after</p> <p>Tighten fuel line connections.</p> <p>Replace switch.</p> <p><u>a.</u> Switch to HI.</p> <p><u>b.</u> Clean or replace filter(s) (fig. 9-133, 134).</p> <p><u>c.</u> Check valves (table 8-14). If defective, replace heater.</p> <p><u>a.</u> Check igniter and resistors (table 8-14). Replace igniter if defective. If resistor is defective, replace heater.</p> <p><u>b.</u> Replace heater.</p> <p><b>NOTE.</b> <u>If banging is severe and persists on several successive starts, or if smoking condition does not clear itself after several minutes of operation, replace heater.</u></p>

Table 8-3. TROUBLESHOOTING - CONTINUED

Malfunction	Probable cause	Corrective action
<p>60. Heater will not start</p>	<p style="text-align: center;"><b>WINTERIZATION COOLANT - HEATER</b></p> <p><u>a.</u> Improper starting procedure.</p> <p><u>b.</u> No electrical power</p> <p><u>c.</u> Exhaust restriction</p> <p><u>d.</u> Insufficient fuel flow</p> <p style="padding-left: 20px;">(1) Clogged filter(s) in line or pump</p> <p style="padding-left: 20px;">(2) No electrical power to fuel pump</p> <p style="padding-left: 20px;">(3) Defective fuel pump</p> <p style="padding-left: 20px;">(4) Defective fuel shutoff solenoid</p> <p style="padding-left: 20px;">(5) Overheat switch defective Replace if defective</p> <p><u>e.</u> Flame detector switch out of adjustment or defective</p> <p><u>f.</u> Defective igniter or igniter resistor</p> <p><u>g.</u> Blower motor inoperative</p> <p style="padding-left: 20px;">(1) No electrical power to motor</p> <p style="padding-left: 20px;">(2) Defective motor</p> <p><u>h.</u> Other causes</p>	<p><u>a.</u> See table 2-13 for proper starting procedure.</p> <p><u>b.</u> Check lead #561 and circuit breaker (table 8-14. 1). Repair or replace defective components.</p> <p><u>c.</u> Remove obstruction.</p> <p><u>d.</u></p> <p style="padding-left: 20px;">(1) Clean or replace filter(s) (fig. 9-134).</p> <p style="padding-left: 20px;">(2) With switch in START position, check voltage at fuel pump. If no power, check control box start switch and circuit #563A (table 8-14. 1). Replace switch if defective. Repair or replace harness as necessary (fig. 12-9, 10).</p> <p style="padding-left: 20px;">(3) If pump has power but will not run, replace pump.</p> <p style="padding-left: 20px;">(4) Check solenoid (table 8-14.1). Replace if defective.</p> <p style="padding-left: 20px;">(5) Check switch (table 8-14.1)</p> <p><u>e.</u> Check switch (table 8-14. 1). Adjust or replace as necessary.</p> <p><u>f.</u> Check igniter and resistor (table 8-14.1). Replace igniter if defective. If resistor is defective replace heater.</p> <p><u>g.</u></p> <p style="padding-left: 20px;">(1) Check lead #562 and blower motor resistor (table 8-14.1). Repair or replace harness as necessary. If resistor is defective replace heater.</p> <p style="padding-left: 20px;">(2) If motor has power but will not run, replace heater.</p> <p><u>h.</u> If causes "a" through "g" have, been eliminated and heater still does not start, replace heater.</p>

Table 8-3. TROUBLESHOOTING - CONTINUED

Malfunction	Probable cause	Corrective action
<b>WINTERIZATION COOLANT - HEATER - Continued</b>		
<p>61. Heater starts but indicator light does not come on.</p>	<p><u>a.</u> Lamp burned out</p> <p><u>b.</u> Open circuit</p> <p><u>c.</u> Flame detector switch out of adjustment or defective</p>	<p><u>a.</u> Press to test. Replace if burned out.</p> <p><u>b.</u> Check circuits #564 and #565 (table 8-14. 1). Repair or replace harness as necessary (fig. 12-10).</p> <p><u>c.</u> Hold switch in START position and operate heater for 3 or 4 minutes. Check voltage at P9, figure 8-11. 1. If no power, adjust or replace flame detector switch. (fig. 12-12).</p>
<p>62. Heater overheats and shuts off</p>	<p><u>a.</u> Insufficient coolant flow,</p> <p>(1) No power to coolant circulating pump place harness as necessary</p> <p>(2) Coolant pump defective not run, replace pump.</p> <p>(3) Kinked hose</p> <p>(4) System air-locked (table 12-1, "Installation").</p> <p>(5) Improper coolant mixture (frozen or slushy)</p> <p><u>b.</u> Excessive fuel flow</p>	<p><u>a.</u></p> <p>(1) Check circuit #585 (table 8-14.1). Repair or re-</p> <p>(2) If pump has power but will</p> <p>(3) Straighten hose.</p> <p>(4) Bleed air from system</p> <p>(5) Drain and fill system with proper coolant (table 9-2. 1:</p> <p><u>b.</u> (Usually accompanied by excessive smoke). Replace heater.</p>
<p>63. Heater overheats but does not shut off</p>	<p>Same causes as 62 above, plus a defective overheat switch</p>	<p>Refer to 62 above. Correct cause of overheating and replace overheat switch, or replace heater.</p>
<p>64. Heater starts and runs but stops after a short interval (Control box switch on RUN)</p>	<p><u>a.</u> Clogged filter in line or pump,</p> <p><u>b.</u> Overheat switch out of calibration.</p> <p><u>c.</u> Excessive carbon in burner</p> <p><u>d.</u> Defective fuel valve</p>	<p><u>a.</u> Clean or replace filter(s) (fig. 9-134).</p> <p><u>b.</u> Replace switch (fig. 12-12).</p> <p><u>c.</u> Replace heater.</p> <p><u>d.</u> Replace heater.</p>

Table 8-3. TROUBLESHOOTING - CONTINUED

Malfunction	Probable cause	Corrective action
<b>WINTERIZATION COOLANT - HEATER - Continued</b>		
65. Heat output too low	<ul style="list-style-type: none"> <li>a. HI-LO switch on LO</li> <li>b. HI-LO switch defective</li> <li>c. Defective coolant thermostat.</li> <li>d. Clogged filter in pump or line</li> <li>e. Excessive carbon in burner</li> <li>f. Defective fuel valve</li> </ul>	<ul style="list-style-type: none"> <li>a. Switch to HI.</li> <li>b. Check switch (table 8-14. 1) and replace if defective.</li> <li>c. Check thermostat (table 8-14. 1) and replace if defective.</li> <li>d. Clean or replace filter(s) (fig. 9-134).</li> <li>e. Replace heater.</li> <li>f. Replace heater.</li> </ul>
66. Heater burns on high heat continuously, even when switched to LO.	<ul style="list-style-type: none"> <li>f. Defective diode</li> </ul>	<ul style="list-style-type: none"> <li>Check diode (table 8-14. 1). If defective replace heater.</li> </ul>
66. 1 Heater will not operate on high heat place harness as necessary	<ul style="list-style-type: none"> <li>a. Open circuit</li> <li>b. Defective coolant thermostat</li> <li>c. Defective restriction thermostat</li> <li>d. Defective restriction solenoid</li> <li>e. Defective diode</li> <li>f. Excessive carbon in heater</li> </ul>	<ul style="list-style-type: none"> <li>a. Check circuit #563 (table 8-14.1). Repair or re-</li> <li>b. Check thermostat (table 8-14. 1). Replace thermostat if defective.</li> <li>c. Check thermostat (table 8-14.1). If thermostat is defective, replace heater.</li> <li>d. Check solenoid (table 8-14.1). If defective, replace heater.</li> <li>e. Check diode (table 8-14.1). If defective replace heater.</li> <li>f. Replace heater.</li> </ul>
66. 2. Blower and coolant circulating pump continue to operate more than 5 minutes after heater shuts off.	<ul style="list-style-type: none"> <li>f. Defective flame detector switch.</li> </ul>	<ul style="list-style-type: none"> <li>Replace switch (fig. 12-12).</li> </ul>



Table 8-3. TROUBLESHOOTING - CONTINUED

Malfunction	Probable cause	Corrective action
<p>66. 3. Excessive smoke, or "bangs" on starting</p>	<p><b>WINTERIZATION COOLANT - HEATER - Continued</b>                      Fuel accumulation due to slom starting.                      (1) Defective igniter                       (2) Defective restriction solenoid or air valve                       (3) Defective fuel valve</p>	<p>(1) Check igniter (table 8-14. 1), and replace if defective (fig. 12-12).                      (2) Check solenoid and valve (table 8-14. 1). If defective, replace heater.                      (3) Replace heater.</p> <p><b>NOTE.</b> <u>If banging is severe and persists on several successive starts, or if smoking condition does not clear itself after several minutes of operation, replace heater.</u></p>
<p>66.4 BLOWER MOTORS WILL NOT OPERATE</p>	<p>(1) INSUFFICIENT OIL PRESSURE TO ACTUATE OIL PRESSURE SWITCH.                       (2) OIL PRESSURE SWITCH DEFECTIVE                       (3) WIRING DISCONNECTED, WORN OR SHORT CIRCUITED.                       (4) OPEN CIRCUIT BREAKER.                       (5) DEFECTIVE RELAY.                       (6) DEFECTIVE BLOWER MOTORS</p>	<p>(1) CHECK OIL LEVEL (LO 9-2350-230-12)                       (2) REPLACE.                       (3) INSPECT CIRCUITS 58, 58A, 581 AND HARNESS 11665313 OR PROPER CONNECTION, VOLTAGE AND CONTINUITY.                       (4) REPLACE.                       (5) REPLACE.                       (6) REPLACE.</p>
<p>66.5 BLOWER MOTORS OPERATE BUT AIR FLOW RESTRICTED.</p> <p>NOTE. ALL OTHER MALFUNCTIONS NOT LISTED, REPORT IMMEDIATELY TO DIRECT SUPPORT.</p>	<p>BLOWER OR OUTLET HOSE CLOGGED.</p>	<p>INSPECT AND CLEAN.</p>

Table 8-3. TROUBLESHOOTING - CONTINUED

Malfunction	Probable cause	Corrective action
67. Front bilge pump does not operate when switch and indicator light is on	<p style="text-align: center;"><b>BILGE PUMP SYSTEM</b></p> <p><u>a.</u> Loose electrical connection</p> <p><u>b.</u> Open or defective circuit breaker</p> <p><u>c.</u> Defective relay</p> <p><u>d.</u> Defective bilge pump</p>	<p><u>a.</u> Inspect and tighten connections as required.</p> <p><u>b.</u> If circuit breaker does not reset in three minutes, replace (fig. 9-100).</p> <p><u>c.</u> Replace relay (fig. 9-108).</p> <p><u>d.</u> Replace bilge pump (figs. 9-130, 131).</p>
68. Front bilge pump does not operate when switch is on, indicator light off	<p><u>a.</u> Master switch off</p> <p><u>b.</u> Loose electrical connections, defective switch or circuit breaker.</p> <p><u>c.</u> Defective switch</p>	<p><u>a.</u> Turn master switch on.</p> <p><u>b.</u> Inspect and tighten or replace components as necessary.</p> <p><u>c.</u> Replace switch (fig. 9-103).</p>
69. Both rear bilge pumps do not operate when switch and indicator light is on	<p><u>a.</u> Loose electrical connections.</p> <p><u>b.</u> Defective relay</p> <p><u>c.</u> Circuit breakers open or defective</p>	<p><u>a.</u> Inspect and tighten connections as required.</p> <p><u>b.</u> Replace relay (fig. 9-108).</p> <p><u>c.</u> If circuit breakers do not reset in three minutes, replace (fig. 9-100).</p>
70. Both rear bilge pumps do not operate when switch is on, indicator light off required.	<p><u>a.</u> Master switch off</p> <p><u>b.</u> Loose electrical connections.</p> <p><u>a.</u> Defective switch</p>	<p><u>a.</u> Turn on master switch.</p> <p><u>b.</u> Inspect and tighten electrical connections, as</p> <p><u>c.</u> Replace switch (fig. 9-103).</p>
71. Only one rear bilge pump operates	<p><u>a.</u> Loose electrical connections.</p> <p><u>b.</u> Circuit breaker open or defective</p> <p><u>c.</u> Defective bilge pump</p>	<p><u>a.</u> Inspect and tighten connections to inoperative pump and associated circuit breaker.</p> <p><u>b.</u> If circuit breaker does not reset in three minutes, replace (fig. 9-108).</p> <p><u>c.</u> Replace bilge pump (figs. 9-129, 130).</p>

Table 8-3. TROUBLESHOOTING - CONTINUED

Malfunction	Probable cause	Corrective action
	<p><b>TURRET ELECTRICAL SYSTEM ACCESSORY SYSTEM</b></p>	
72. Ventilating fan does not operate when switch is on	<p><u>a.</u> Master switch off</p>	<p><u>a.</u> Turn master switch ON.</p>
73. Fan motor vibrates excessively.	<p><u>b.</u> Loose wiring</p>	<p><u>b.</u> Inspect and tighten electrical connections as required.</p>
74. Insufficient circulation of air in vehicle when fan is on	<p><u>c.</u> Ventilating fan switch defective.</p>	<p><u>c.</u> Replace fan (fig. 10-35).</p>
	<p><u>d.</u> Defective fan motor Worn bearings</p>	<p><u>d.</u> Replace fan. Replace ventilating fan.</p>
	<p><u>a.</u> Obstructed fan intake</p>	<p><u>a.</u> Clean intake.</p>
	<p><u>b.</u> Low input voltage</p>	<p><u>b.</u> Check cable terminals for corrosion and loose connections. Clean and tighten. Check battery voltage.</p>
75. Dome light or lights inoperative.	<p><u>c.</u> Fan slipping or damaged</p>	<p><u>c.</u> Replace fan (fig. 10-35).</p>
	<p><u>a.</u> Master switch off</p>	<p><u>a.</u> Turn master switch ON.</p>
	<p><u>b.</u> Faulty wiring circuit from dome lights to accessory box or contact ring.</p>	<p><u>b.</u> Notify support maintenance.</p>
	<p><u>c.</u> Lamps burned out</p>	<p><u>c.</u> Check and replace defective lamps (fig. 9-96).</p>
	<p><u>d.</u> Faulty switch or switches in dome lights</p>	<p><u>d.</u> Check and replace dome lights switches if defective (figs. 9-95 and 9-96).</p>
76. Air filter unit inoperative	<p><u>a.</u> Loose or defective electrical lead</p>	<p><u>a.</u> Tighten or repair lead (fig. 10-30).</p>
	<p><u>b.</u> Defective rheostat</p>	<p><u>b.</u> Notify support maintenance.</p>
	<p><u>c.</u> Purifier motor overheating or defective</p>	<p><u>c.</u> Replace precleaner and housing. Refer to TM 3-4240-236-20P.</p>

Table 8-3. TROUBLESHOOTING - CONTINUED

Malfunction	Probable cause	Corrective action
77 Lack of air at gas-particulate filter unit face piece	<p><b>TURRET ELECTRICAL SYSTEM ACCESSORY SYSTEM - Continued</b></p> <p><u>a</u> Hose disconnected or damaged</p> <p><u>b</u> Particulate filter clogged</p>	<p><u>a</u> Connect or replace hose.</p> <p><u>b</u> Replace filter (fig 10-31).</p>
78 Split hatch doors will not close properly.	<p><b>COMMANDER'S CUPOLA</b></p> <p><u>a</u> Doors not aligned</p> <p><u>b</u> Defective or loose seals.</p> <p><u>c</u> Defective lock and catch assemblies.</p>	<p><u>a</u> Notify support maintenance.</p> <p><u>b</u> Replace seals.</p> <p><u>c</u> Notify support maintenance.</p>
79 Cupola leaks	<p><u>a</u> Defective hatch seals.</p> <p><u>b</u> Vision blocks not sealed properly.</p>	<p><u>a</u> Replace seals.</p> <p><u>b</u> Replace sealer (fig 10-49).</p>
80 Cupola will not traverse or erratic in power mode.	<p><u>a</u> Master switch off</p> <p><u>b</u> Defective brush assemblies in electrical contact ring.</p> <p><u>c</u> Defective switches in control box</p> <p><u>d</u> Damaged wiring harnesses</p> <p><u>e</u> Foreign material in race ring.</p>	<p><u>a</u> Turn master switch ON.</p> <p><u>b</u> Notify support maintenance.</p> <p><u>c</u> Replace control box (fig 10-33 and 10-34).</p> <p><u>d</u> Notify support maintenance.</p> <p><u>e</u> Clean race ring.</p>

Table 8-3. TROUBLESHOOTING - CONTINUED

Malfunction	Probable cause	Corrective action
<b>COMMANDER'S CUPOLA - Continued</b>		
80 Cupola will not traverse or erratic in power mode - continued	<u>f</u> Damaged race ring  <u>g</u> Traverse mechanism motor defective.	<u>f</u> Notify support maintenance.  <u>g</u> Notify support maintenance.
81 Cupola will not traverse manually	<u>a</u> Defective traverse mechanism <u>b</u> Defective cupola race ring	<u>a</u> Notify support - maintenance. <u>b</u> Notify support maintenance.
<b>COMMANDER'S CUPOLA - M551A1 ONLY</b>		
81.1 Readout 9995 appears at RANGE (METERS) and 1 appears at RETURNS at commander's display when cupola is traversed electrically.	Commander's cupola contact brush assemblies or electrical contact rings are worn, dirty, or out of adjustment.	Notify support maintenance to inspect, clean, and adjust contact brush assemblies.
81.2 Cupola drive mechanism makes loud noise when ROTATION switch is actuated.	Magnetic switch not disengaged	Notify support maintenance to check clutch electrical circuit.
81.3 Cupola magnetic clutch activates when CUPOLA/LASER switch is turned on.	Cal .50 machine gun direction cable is severed or has a grounded wire	Check/replace cable and/or traverse switch assembly (fig 10-49.2.1).
81.4 Cupola traverses immediately when CUPOLA/LASER switch is turned on.	Cal .50 machine gun direction cable is severed or has a grounded wire	Check/replace cable and/or traverse switch assembly (fig 10-49.2.1).

Table 8-3. TROUBLESHOOTING - CONTINUED

Malfunction	Probable cause	Corrective action
<b>COMMANDER'S CUPOLA M551A1 ONLY - Continued</b>		
81.5 Cupola magnetic clutch engages too soon, not letting drive motor slow down.	Inoperative speed switch in drive motor.	Notify support maintenance.
81.6 Cupola drive motor burns up	Motor oil seals leaking	Notify support maintenance to replace drive motor.
81.7 CUPOLA ALIGN switch inoperative nector or defective wiring harness	Bad contact in electrical con-	Inspect electrical connectors for bent or broken pins, loose connections, dirt or moisture in connectors, or damage to wiring harness. Notify support maintenance.
81.8 Cupola drive motor runs at slow speed only	Defective relay in resistor box	Replace resistor box assembly (fig 10-35.4).
81.9 Cupola stops before reaching front position during automatic align cycle.	Defective resistor in resistor box	Replace resistor box assembly (fig 10-35.4).
81.10 Automatic align cycle stops when align switch is released.	Defective relay in cupola (relay) control box	Replace cupola (relay) control box (fig 10-33).
81.11 Automatic cupola align function does not work	<u>a</u> Defective align/stop switch in cupola laser control box	<u>a</u> Replace cupola/laser control box assembly (fig 10-35.2).
	<u>b</u> Defective diode in cupola (relay) control box	<u>b</u> Replace cupola (relay) control box (fig 10-33).

Table 8-3. TROUBLESHOOTING - CONTINUED

Malfunction	Probable cause	Corrective action
81.11 Automatic cupola align function does not work - continued	<p align="center"><b>COMMANDER'S CUPOLA M551A1 ONLY - Continued</b></p> <p><u>c</u> Defective or - maladjusted limit switch in cupola resolver alignment mechanism</p>	<p><u>c</u> Notify support maintenance to check cupola resolver alignment mechanism limit switches.</p>
81.12 Cupola continues to oscillate after returning to front position during the automatic align cycle.	Defective relay in cupola/laser control box	Replace cupola/laser control box assembly (fig 10-35.2).
82 Power light and ready light do not light after lamps have been checked	<p align="center"><b>TURRET ELECTRIC DRIVE CONTROL</b></p> <p><u>a</u> No electrical power to turret</p> <p><u>b</u> Defective component in accessory box</p>	<p><u>a</u> Check operation of missile subsystem; if no operation, replace contact ring. If missile subsystem operates, proceed to step b.</p> <p><u>b</u> Replace accessory box (fig 10-4) If malfunction still occurs, notify support maintenance.</p>
83 Power light illuminates but ready light does not illuminate	Defective component in accessory box	Replace accessory box. If malfunction still occurs, notify support maintenance.
84 Ready light illuminates but earlier or later than timer tolerance (18-22 seconds) .	Defective component in accessory box	Replace accessory box.

Table 8-3. TROUBLESHOOTING - CONTINUED

Malfunction	Probable cause	Corrective action	
<p>85 With power and ready lights illuminated, squeezing palm switch does not activate system</p> <p>86 Motor-generator does not come up to speed.</p> <p>87 With power and ready lights illuminated, palm switch depressed, and motor-generator operating, control handle does not drive gun and/or turret</p>	<p><b>TURRENT ELECTRIC DRIVE CONTROL - Continued</b></p>	<p>a Operate other control handle. If it operates, replace defective control handle (fig 10-7). If it does not operate, proceed to step b.</p> <p>b Replace accessory box.</p> <p>Replace motor-generator (fig 10-6).</p> <p>a Release turret lock (fig 10-36).</p> <p>b Check vehicle</p> <p><b>NOTE</b> Do not operate system on battery power only.</p>	
	<p>a Defective control handle</p>		
	<p>b Defective component in accessory box.</p>		
<p>86 Motor-generator does not come up to speed.</p>	<p>Defective motor-generator</p>	<p>Replace motor-generator (fig 10-6).</p>	
<p>87 With power and ready lights illuminated, palm switch depressed, and motor-generator operating, control handle does not drive gun and/or turret</p>	<p>a Turret traverse - lock engaged</p>	<p>a Release turret lock (fig 10-36).</p>	
	<p>b Low voltage power.</p>	<p>b Check vehicle</p>	
	<p>(8-32.4 blank)/8-32.3</p>		



Table 8-3. TROUBLESHOOTING - CONTINUED

Malfunction	Probable cause	Corrective action
<p>87. With power and ready lights illuminated, palm switch depressed, and motor-generator operating, control handle does not drive gun and/or turret - Continued</p>	<p style="text-align: center;"><b>TURRENT ELECTRIC CONTROL - Continued</b></p> <p><u>c.</u> Defective elevating or traversing mechanism clutch or clutch brush</p> <p><u>d.</u> Defective control handle</p> <p><u>e.</u> System malfunction</p>	<p><u>c.</u> Attempt to operate turret and weapon manually with palm switch depressed. If turret or weapon moves, replace clutch brush (fig. 10-10).</p> <p><u>d.</u> Operate switch and/or both control handles. Replace handle if defective (fig. 10-7).</p> <p><u>e.</u> Perform test set procedures (table 10-3).</p>
<p>88. Two second drop-out delay inoperative when palm switch released.</p>	<p><u>a.</u> Defective component in accessory box</p>	<p><u>a.</u> Replace accessory box (fig. 10-4).</p>
<p>88. 1 Palm switch energized without being depressed</p>	<p>Dirt collected under heel of palm switch</p>	<p>Depress palm switch and remove dirt with thin bladed tool.</p>
<p>89. Excessive dead space in control handle when traversing and/or elevating</p>	<p><u>a.</u> Traversing and/or elevating systems incorrectly adjusted, or control handle defective.</p> <p><u>b.</u> Free mechanical motion in control handles.</p>	<p><u>a.</u> Perform test set procedures (table 10-3).</p> <p><u>b.</u> Replace handle (fig. 10-7).</p>
<p>90. Gun-launcher elevates or depresses but speed erratic.</p>	<p><u>a.</u> Poor electrical connections.</p> <p><u>b.</u> Defective control handle</p> <p><u>c.</u> Defective servo motor</p>	<p><u>a.</u> Check and tighten connections.</p> <p><u>b.</u> Check operation with other control handle. Replace defective handle.</p> <p><u>c.</u> Replace servo motor (fig. 10-11).</p>
<p>91. Turret traverses but speed erratic</p>	<p><u>a.</u> Poor electrical connections.</p> <p><u>b.</u> Defective control handle</p> <p><u>c.</u> Defective servo motor</p>	<p><u>a.</u> Check and tighten connections.</p> <p><u>b.</u> Check operation with other control handle. Replace handle if defective (fig. 10-7).</p> <p><u>c.</u> Replace servo motor (fig. 10-11).</p>

Table 8-3. TROUBLESHOOTING - CONTINUED

Malfunction	Probable cause	Corrective action
<p>92. Gun-launcher drives against elevation or depression stops</p> <p>93. No override when commander's palm switch is depressed.</p> <p>94. Excessive drift (creep) in traverse and/or elevation.</p> <p>95. STAB light does not illuminate</p> <p>NOTE. Light does not light in Missile mode.</p> <p>96. In STAB mode, gun/turret has excessive overshoot under control of control handle.</p> <p>97. Traverse and/or elevation servo motor overtorque or during operation</p> <p>98. Motor-generator overheats during operation</p>	<p style="text-align: center;"><b>TURRET ELECTRIC CONTROL - Continued</b></p> <p>a. Poor electrical connection</p> <p>b. Elevation or depression limit switches incorrectly adjusted.</p> <p>Defective override function</p> <p>System out of balance</p> <p>No gyro feedback,</p> <p>Amplifiers out of balance</p> <p>a. Excessive load due to obstruction.</p> <p>b. Replace servo motor (fig. fan.-</p> <p>a. Dirty screens restrict air flow</p> <p>b. Defective servo motor 10-11).</p>	<p>a. Check and tighten connections.</p> <p>b. Notify support maintenance.</p> <p>Perform test set procedure (table 10-3).</p> <p>Perform test set procedure (table 10-3).</p> <p>Perform test set procedure (table 10-3).</p> <p>Perform test set procedure and balance amplifiers (table 10-3).</p> <p>a. Remove obstruction.</p> <p>a. Clean exterior of screens. If contamination is inside, replace motor-generator (fig. 10-6).</p> <p>b. Replace servo motor (fig.</p>
<p>99. Excessive effort required to manually traverse turret</p>	<p style="text-align: center;"><b>TURRET TRAVERSING MECHANISM</b></p> <p>a. Contaminated lubricant on turret race ring.</p> <p>b. Obstruction (internal or external)</p> <p>c. Defective manual drive mechanism.</p> <p>d. Defective traversing mechanism.</p>	<p>a. Notify support maintenance.</p> <p>b. Locate and remove obstruction.</p> <p>c. Notify support maintenance.</p> <p>d. Notify support maintenance.</p>

Table 8-3. TROUBLESHOOTING - CONTINUED

Malfunction	Probable cause	Corrective action
<b>TURRENT TRAVERSING MECHANISM - Continued</b>		
100. Traversing servo motor overheats during electric operation	a. Defective internal fan in traversing servo motor.	a. Notify support maintenance.
101. Traversing mechanism noisy.	b. Excessive load	b. Remove obstructions to operation.
102. Turret does not traverse when rotating manual control handle.	Damaged gear or bearing	Notify support maintenance.
	Defective manual drive mechanism.	Notify support maintenance.
<b>ELEVATING MECHANISM</b>		
103. Operation sluggish or erratic in manual or power mode.	a. Gun or gun shield internal or external obstruction.	a. Remove obstruction.
	b. Worn servo motor brushes or defective servo motor if defective (figs. 10-10, 11).	b. Inspect brushes and replace if worn or replace
	c. Damaged or improperly installed mechanism.	c. Notify support maintenance.
	d. Defective magnetic clutch brush.	d. Replace brush (fig. 10-10).
	e. Defective gun trunnion bearings.	e. Notify support maintenance.
104. Manual handwheel turns freely, but mechanism is inoperative	a. Sheared spring pin in handwheel shaft.	a. Notify support maintenance.
	b. Defective reverse lock (No-Back) clutch or magnetic clutch.	b. Notify support maintenance.
105. Noisy operation	Incorrect shimming or defective gears and bearings.	Notify support maintenance.
106. Failure to operate in power mode	a. Servo motor brushes worn or motor defective	a. Replace brushes or motor (figs. 10-10, 11).

Table 8-3. TROUBLESHOOTING - CONTINUED

Malfunction	Probable cause	Corrective action
106. Failure to operate in power mode - Continued	<p><u>b.</u> Defective magnetic clutch brush or magnetic clutch not operate, notify support</p>	<p><u>b.</u> Replace brush (fig. 10-10). If magnetic clutch does</p>
	<p><u>c.</u> Malfunction in electric drive control system</p>	<p>maintenance. <u>c.</u> Troubleshoot drive control system (above).</p>
107. Excessive effort required to manually elevate or depress gun-launcher	<p><u>a.</u> Obstruction (internal or external)</p>	<p><u>a.</u> Locate and remove obstruction.</p>
	<p><u>b.</u> Defective manual drive mechanism.</p>	<p><u>b.</u> Notify support maintenance.</p>
108. Elevating servo motor overheats during electric operation.	<p><u>c.</u> Contaminated lubricant on elevating mechanism pivots. Defective internal fan in elevating servo motor.</p>	<p><u>c.</u> Lubricate as prescribed in LO 9-2350-230-12.  Notify support maintenance.</p>
109. Elevating mechanism noisy.	<p>Damaged gear or bearing</p>	<p>Notify support maintenance.</p>
<b>CONVENTIONAL WEAPONS ELECTRICAL SYSTEM</b>		
110. READY lights fail to illuminate	<p><u>a.</u> READY lamps defective replace if defective.</p>	<p><u>a.</u> Push lamp to test and</p>
	<p><u>b.</u> Loader's control box switch not in READY position.</p>	<p><u>b.</u> Transfer switch to READY position.</p>
	<p><u>c.</u> Fire control selector switch in OFF position</p>	<p><u>c.</u> Place switch in CONV or MISSILE.</p>
	<p><u>d.</u> Transmitter cover door not open when in MISSILE mode.</p>	<p><u>d.</u> Open transmitter cover door.</p>
	<p><u>e.</u> Loose harness connectors</p>	<p><u>e.</u> Tighten all connectors at relay box, loader's control box, gun-launcher, accessory box, and safe-to-fire indicator switch.</p>

TABLE 8-4. TROUBLESHOOTING - CONTINUED

Malfunction	Probable cause	Corrective action
	<b>CONVENTIONAL WEAPONS ELECTRICAL SYSTEM - Continued</b>	
110. READY lights fail to illuminate - Continued	f. Gun-launcher out of battery.  g. Recoil mechanism pressure too high	f. Operate hand pump to bring gun-launcher into battery. Then check safe-to-fire indicator to ensure correct recoil cylinder pressure (fig. 3-2). g. Bleed off pressure until safe-to-fire indicator switch plunger is in proper position (fig. 3-2). Tighten electrical connector.
111. Gun-launcher misfires with CONV or MISSILE ready lights illuminated.	Firing probe electrical connector loose.	
112. M73 coaxial machine gun fails to fire	a. Fire control switch not in COAX position b. Harness connectors loose	a. Place switch in COAX position. b. Tighten connector on machine gun and connector J5 on relay box (fig. 10-14).
113. Gun-launcher breech	a. Loader's control box SAFE-fails to open or close electrically b. Fire control selector switch in OFF position c. Harness connectors loose	a. Place switch in SAFE READY switch not in SAFE position. b. Place switch in CONV or MISSILE position. c. Tighten all connectors on gun-launcher, relay box, loader's control box, accessory box, and turret and weapon control selector.
114. Telescope reticle dimmer box conventional or missile reticle fails to illuminate.	a. Fire control selector switch in OFF position b. Defective lamp	a. Place switch in CONV or MISSILE position. b. Replace lamp.

TABLE 8-4. TROUBLESHOOTING - CONTINUED

Malfunction	Probable cause	Corrective action
115. PRIME POWER lamp glows	<p style="text-align: center;"><b>MISSILE SUBSYSTEM</b></p> <p>a. Incorrect prime power</p> <p>b. Power supply defective</p>	<p>a. If vehicle engine is off, start engine. Set idle speed to 750 RPM. Check vehicle circuit breaker.</p> <p><b>NOTE. Prime power on W1P2 pins A and B.</b></p> <p>b. Replace power supply. If PRIME POWER lamp continues to glow, request supporting maintenance.</p>
116. POWER SUPPLY lamp glows	<p>a. Modulator defective</p> <p>b. Rate sensor defective</p> <p>c. Tracker or tracker mount defective</p> <p>d. Power supply defective</p>	<p>a. Disconnect W1P3 and W2P2 from the modulator. If POWER SUPPLY lamp goes out, replace modulator. Reconnect cables.</p> <p>b. Disconnect W9P1 from rate sensor. If POWER SUPPLY lamp goes out, replace rate sensor. Reconnect cable.</p> <p>c. Disconnect W6P2 from tracker. If POWER SUPPLY lamp goes out, replace tracker. Reconnect cable. If POWER SUPPLY lamp continues to glow, disconnect W6P5 from tracker mount. If light goes out, replace tracker mount. Reconnect cable.</p> <p>d. Replace power supply. If POWER SUPPLY lamp does not go off, replace signal data converter. Repeat test. If problem is not corrected, replace test checkout panel. Repeat test.</p>
	<p>e. Cables defective</p>	<p>e. Request supporting maintenance.</p>

TABLE 8-4. TROUBLESHOOTING - CONTINUED

Malfunction	Probable cause	Corrective action
<b>MISSILE SUBSYSTEM - Continued</b>		
117 Lamp and meter test) Lamps do not light, and meter does not deflect on test checkout panel	a. No power to test checkout panel  b. Test checkout panel defective.	a. Check cable connections. Refer table 4-1, step B61.  b. Replace test checkout panel. If problem is not corrected, request supporting main- tenance.
118. (Lamp and meter test.) Meter needle does not deflect to meter test band. (But lamps glow)	a. Cable not properly connected. Refer table 4-1, step B61.  b. Defective test checkout panel. and repeat test.	a. Check cable connections.
119. (Lamp and meter test), Meter deflects pro- perly but all lamps do not glow	a. Defective lamps  b. Defective test checkout panel.	b. Replace test checkout panel  a. Replace defective lamps. Refer table 5-6.
120. (Lamp and meter test) Meter illumination lamps do not glow.	a. Defective lamps  b. Test checkout panel defective.	b. Replace test checkout panel. Repeat test. a. Replace defective lamps.
120. 1. (Test checkout panel). Dimmer control does not affect intensity of the lamps	Defective test checkout panel	b. Replace test checkout panel. Repeat test. Replace test checkout panel. Repeat test.
120. 1.1. (Transmitter test) Switch does not remain in the on (up) position for a period of at least 15 seconds	a. Transmitter defective	<b>NOTE. Dimmer control should not affect red indicator lamps.</b> a. Replace transmitter. Repeat test.
<b>CAUTION:</b> Transmitter switch should not remain on longer than 1 minute.		
<b>NOTE. Whenever trans- mitter is replaced, perform transmitter alignment test (figs. 10-20, 10-20.1), and request supporting mainten- ance to perform transmitter beam pattern test.</b>		

TABLE 8-4. TROUBLESHOOTING - CONTINUED

Malfunction	Probable cause	Corrective action
	<b>MISSILE SUBSYSTEM - Continued</b>	
120. 1.1. (Transmitter test switch does not remain in the or (up) position for a period of at least 15 seconds - Continued	<ul style="list-style-type: none"> <li>b. Modulator defective test.</li> <li>c. Test checkout panel defective. Repeat test.</li> <li>d. Power supply defective</li> <li>e. Signal data converter defective</li> </ul>	<ul style="list-style-type: none"> <li>b. Replace modulator. Repeat</li> <li>c. Replace test checkout panel.</li> <li>d. Replace power supply. Repeat test.</li> <li>e. Replace signal data converter. Repeat test. If problem is not corrected, request supporting maintenance.</li> </ul>
120. 2. (Tracker alignment test) Align lever will not remain in the right (up) position	<ul style="list-style-type: none"> <li>a. Signal data converter defective</li> <li>b. Tracker mount defective</li> </ul>	<ul style="list-style-type: none"> <li>a. Remove cable W6P5 from tracker mount. If align lever will now remain in the right (up) position, replace signal data converter. Repeat test.</li> <li>b. Replace tracker mount. Repeat test. If problem is not corrected, request supporting maintenance. Replace test checkout panel. Repeat test.</li> </ul>
120. 3. (Tracker alignment test) TRACKER ALIGN switch on test checkout panel will not remain in the on (up) position.	Test checkout panel defective	Replace test checkout panel. Repeat test.
120. 4. (Tracker alignment test) cannot null meter using AZ or EL adjustment screws, located on telescope mount.	<ul style="list-style-type: none"> <li>a. Error lever not in the left (down) position</li> <li>b. Checksight source lamp defective source spot-of-light is visible. If not visible, replace checksight source lamp.</li> </ul> <p>that telescope filter lever is in the clear position. Temporarily cover or shade telescope opening outside turret to make spot-of-light more visible.</p>	<ul style="list-style-type: none"> <li>a. Move error lever to the left (down) position.</li> </ul> <p>NOTE. Verify that align lever is in the right (up) position.</p> <ul style="list-style-type: none"> <li>b. Look into the telescope. Verify that checksight</li> </ul> <p>NOTE. Check to insure</p>



TABLE 8-4. TROUBLESHOOTING - CONTINUED

Malfunction	Probable cause	Corrective action
<p>120. 4. (Tracker alignment test) cannot null meter using AZ or EL adjustment screws, located on telescope mount. - Continued</p>	<p style="text-align: center;"><b>MISSILE SUBSYSTEM - Continued</b></p> <p>c. Tracker or power supply defective</p> <p>d. Signal data converter defective</p> <p>e. Test checkout panel defective.</p> <p>f. Telescope mount defective</p>	<p>Look into telescope. If checksight source spot-of-light is not sharply defined or larger than normal, there is moisture in telescope or telescope mount.</p> <p>Look into telescope from outside turret to verify that the align prism is visible and in proper position.</p> <p>c. Listen for tracker motor. If operating, listen for rate sensor.</p> <p>Rate sensor gyros operating; tracker motor not operating. Replace tracker. Repeat test.</p> <p>Rate sensor gyros and tracker motor not operating. Replace power supply. Repeat test.</p> <p><b>NOTE. With excessive noise in turret, rate sensor gyros and tracker motor may be difficult to hear.</b></p> <p>d. Replace signal data converter Repeat test.</p> <p>e. Replace test checkout panel. Repeat test.</p> <p>f. Place EL or AZ adjustment screws (on telescope mount) at mid range, then adjust the other screw for a null on the meter. The AZ or EL switch on test checkout panel must be in correct position.</p>

TABLE 8-4. TROUBLESHOOTING - CONTINUED

Malfunction	Probable cause	Corrective action
<p>120.4. (Tracker alignment test) cannot null meter using AZ or EL adjustment screws, located on telescope mount. - Continued</p> <p>120. 5. Align lever does not reset when RESET switch on test checkout panel</p> <p>120. 6. (System self- test) SYSTEM TEST switch will not remain on (up)</p> <p>120. 7. (System self-test) CHECKOUT PANEL lamp glows after initiation of system test</p> <p>120. 8. (System self-test) TRACKER lamp glows at completion of test</p>	<p style="text-align: center;"><b>MISSILE SUBSYSTEM - Continued</b></p> <p>a. Fuse on telescope mount defective</p> <p>b. Test checkout panel defective. is activated</p> <p>c. Signal data converter defective</p> <p>d. Telescope mount defective</p> <p>Test checkout panel defective</p> <p>a. Test checkout panel defective. Repeat test.</p> <p>b. Signal data converter defective</p> <p>a. Align lever not in right (up) position</p> <p>b. Tracker not properly aligned.</p>	<p><b>NOTE. The EL and AZ adjustment may be so far out of alignment that checksight source may not be seen by tracker. It is possible to observe the checksight source in telescope and bring it near center enough to get a meter indication.</b></p> <p>If meter still will not null, replace telescope mount; repeat test. If problem is not corrected, request supporting maintenance.</p> <p>a. Replace fuse on telescope mount. Repeat test.</p> <p>b. Replace test checkout panel. Repeat test.</p> <p>c. Replace signal data converter Repeat test.</p> <p>d. Replace telescope mount. Repeat test. If problem is not corrected, request supporting maintenance. Replace test checkout panel. Repeat test. If problem is not corrected, request supporting maintenance.</p> <p>a. Replace test checkout panel.</p> <p>b. Replace signal data converter Repeat test. If problem is not corrected, request supporting maintenance.</p> <p>a. Place align lever in right (up) position. Repeat test.</p> <p>b. Perform tracker alignment. Refer table 2-12. Repeat test.</p>

TABLE 8-4. TROUBLESHOOTING - CONTINUED

Malfunction	Probable cause	Corrective action
<p>120. 8. (System self-test) TRACKER lamp glows at comple- tion of test. - Continued</p>	<p style="text-align: center;"><b>MISSILE SUBSYSTEM - Continued</b></p> <p>c. Tracker motor does not run in system self-test</p> <p>d. Tracker defective</p> <p>e. Signal data converter defective problem is not corrected, request supporting main- tenance.</p>	<p>c. Listen for tracker motor during system self-test, if tracker motor is not running. (See NOTE)</p> <p>NOTE. If tracker motor runs in tracker align but not in system self-test, probable cause may be signal data con- verter or test checkout panel</p> <p>Replace tracker. Per- form tracker alignment. Refer table 2-12. Re- peat test.</p> <p>If tracker does not start, replace signal data con- verter. Repeat test.</p> <p>d. Replace tracker. Perform tracker alignment. Refer table 2-12. Repeat test.</p> <p>e. Replace signal data con- verter. Repeat test. If</p>
<p>120. 9. (System self-test) SIG DATA CONV glows at com- pletion of test</p>	<p>a. Error lever not in right (up) position</p> <p>b. Tracker not properly aligned</p>	<p>a. Place error lever in right (up) position. Repeat test</p> <p>b. Perform tracker alignment. Refer table 2-12. NOTE. After performing tracker align, reference the missile reticle (observe on telescope) one mil circle on checksight source. With align lever right (up) and error lever left (down) place error lever right(up) and observe checksight source move out of the one mil circle of missile reticle. The checksight source should position itself approx- imately two mils northeast from center of missile reticle.</p>

TABLE 8-4. TROUBLESHOOTING - CONTINUED

Malfunction	Probable cause	Corrective action
<p>120. 9. (System self-test SIG DATA CONV glows at completion of test. - Continued</p> <p>120. 10. (System self-test MOD lamp glows at completion of test</p> <p>120. 11. (System self-test XMTR lamp glows at completion of test</p>	<p><b>MISSILE SUBSYSTEM - Continued</b></p> <p>c. Tracker defective</p> <p>d. Signal data converter defective</p> <p>a. Modulator defective test.</p> <p>b. Transmitter defective</p> <p>a. Transmitter defective</p>	<p>c. Replace tracker. Perform tracker alignment. Refer table 2-12. Repeat test.</p> <p>d. Replace signal data converter, Repeat test. If problem is not corrected, request supporting maintenance.</p> <p>a. Replace modulator. Repeat</p> <p>b. Replace transmitter. Repeat test. If problem is not corrected, request supporting maintenance.</p> <p><b>NOTE. Whenever transmitter is replaced, perform transmitter alignment test (figs. 10-20, 10-20. 1), and request supporting maintenance to perform transmitter beam pattern test.</b></p> <p>a. Replace transmitter. Repeat test.</p> <p><b>NOTE. Before replacing transmitter, perform transmitter test. If transmitter switch on test checkout panel will not remain on (up) for 15 seconds, replace transmitter. If switch remains on (up) for 15 seconds, replace modulator.</b></p> <p><b>CAUTION: Transmitter switch should not remain on longer than one minute</b></p> <p><b>NOTE. Whenever transmitter is replaced, perform transmitter alignment test (figs. 10-20, 10-20. 1), and request supporting maintenance to perform transmitter beam pattern test.</b></p>

TABLE 84. TROUBLESHOOTING - CONTINUED

Malfunction	Probable cause	Corrective action
<p>120. 11. (System self-test XMTR lamp glows at completion of test. - Continued</p> <p>120.12. ( System self-test) TRACKER and SIG. DATA CONV lamps glow at completion of test</p> <p>120. 13. (System self-test) Gunner's ready lamp does not light.</p>	<p style="text-align: center;"><b>MISSILE SUBSYSTEM - Continued</b></p> <p>b. Modulator defective</p> <p>a. Vehicle input circuit defective</p> <p>b. In battery limit switch out of adjustment or defective</p> <p>a. Transmitter door not open</p> <p>b. Transmitter door switch defective out of adjustment</p> <p>c. Breech not fully closed close breech limit switch.</p> <p>d. Gun launcher not in battery</p> <p>e. Recoil mechanism not correct pressure</p> <p>f. Loader's safe/ready switch in safe position or is defective</p> <p>g. Fire control selector switch not in missile position</p>	<p>b. Replace modulator. Repeat test. If problem is not corrected, request supporting maintenance.</p> <p>a. Disconnect cable 7J2 from the test checkout panel and repeat system self-test. Refer table 2-12. If SIG DATA CONV and TRACKER lamps do not glow, the trouble is in the vehicle input circuit (relay box, etc. ).</p> <p>b. Adjust or replace in battery limit switch. Refer figure 11-12. Repeat test. If problem is not corrected request supporting maintenance.</p> <p>a. Check that transmitter door lever is pushed in and locked.</p> <p>b. Check switch for proper operation. Adjust or replace (figure 10-21, 10-22).</p> <p>c. Open and reclose breech to</p> <p>d. In battery limit switch out of adjustment. Adjust or replace. Refer figure 11-2</p> <p>e. Increase or decrease pressure as required (see fig. 3-2).</p> <p>f. Check switch position and place in ready position.</p> <p>g. Put fire control switch in missile position.</p> <p>NOTE. Gunner's and loader's ready lamps also lights in conventional position on selector switch.</p>

TABLE 8-4. TROUBLESHOOTING - CONTINUED

Malfunction	Probable cause	Corrective action
<b>MISSILE SUBSYSTEM - Continued</b>		
120. 13. 1. Check switch for proper operation. Lamp glows with transmitter door closed.	Gunner's ready adjustment or defective	Transmitter door switch out of position. Adjust or replace. Refer figures 10-21 and 10-22
120. 14. Null meter needle does not deflect when turret is moved in azimuth or elevation	a. Rate sensor defective  b. Test checkout panel defective c. Defective gyro selector d. Defective 4A6K2 relay	a. Replace rate sensor if:  (1) Audible hum is not heard from rate sensor and  (2) Rate sensor is not warm to touch. b. Replace test checkout panel. Repeat test. c. Replace gyro selector. d. Replace board 4A6.
121. (System self-test verification) Tracker motor does not run when fire trigger is pulled	a. All firing conditions not present  b. No fire pulse to test checkout panel  c. Test checkout panel defective	a. Check table 3-4.1 to assure that "conditions prior to firing" are present.  b. Disconnect cable from test checkout panel 7J2 and monitor on the cable plug between pins "C" (POS) "G" (GROUND) for the fire pulse, as fire trigger is pulled. If fire pulse is not present, check for loose cable connectors at relay box, loader's control box, gun launcher, accessory box. c. If fire pulse is present at (7J2) test checkout panel and tracker does not run, replace test checkout panel, Repeat test. If problem is not corrected, request supporting maintenance.

TABLE 8-4. TROUBLESHOOTING - CONTINUED

Malfunction	Probable cause	Corrective action
<b>MISSILE SUBSYSTEM Continued</b>		
121.1. Tracker lamp fails to glow when the ALIGN and ERROR levers are in the fully left position and the system test switch is in the up position.	<ul style="list-style-type: none"> <li>a. Defective signal data converter</li> <li>b. Defective test checkout panel.</li> </ul>	<ul style="list-style-type: none"> <li>a. Replace the signal data converter.</li> <li>b. Replace the test checkout</li> </ul>
121.2. Sig data conv lamp fails to glow when the ALIGN lever is positioned fully right and the ERROR lever is fully left with the system test switch in the up position.	<ul style="list-style-type: none"> <li>a. Defective signal data converter</li> <li>b. Defective test checkout panel.</li> </ul>	<ul style="list-style-type: none"> <li>a. Replace the signal data converter.</li> <li>b. Replace the test checkout</li> </ul>
121.3. Test checkout panel fails to reset; ALIGN lever fails to move fully left; tracker motor fails to stop running within 3 seconds after the fire trigger is pulled and ALIGN lever is fully right and system test switch is in the up position.	<ul style="list-style-type: none"> <li>a. Defective test checkout panel.</li> <li>b. Vehicle firing circuit defective.</li> <li>c. Defective tracker mount</li> </ul>	<ul style="list-style-type: none"> <li>a. Replace the test checkout</li> <li>b. Notify support maintenance.</li> <li>c. Notify support maintenance.</li> </ul>
<b>M81/EI GUN-LAUNCHER</b>		
122. Insufficient current available at firing probe to fire weapon	<ul style="list-style-type: none"> <li>a. Firing probe assembly front contact corroded and/or defective</li> <li>b. Firing probe contact assembly not adjusted properly</li> <li>c. Open or grounded firing circuit in electrical wiring harness</li> </ul>	<ul style="list-style-type: none"> <li>a. Clean contact with fine steel wool or replace firing probe if cracked or defective (fig. 11-13).</li> <li>b. Make adjustment and perform continuity check (table 11-2).</li> <li>c. Check continuity between plug at firing probe (P107, circuits a and b) and large input power receptacle (P102, circuits a and p) respectively. Replace harness if defective. (See caution note below. )</li> </ul>

TABLE 8-4. TROUBLESHOOTING - CONTINUED

Malfunction	Probable cause	Corrective action
<p>122. Insufficient current available at firing probe to fire weapon-Continued</p> <p><b>CAUTION:</b> control box. Notify support maintenance if malfunction still occurs.</p> <p>123. Breech mechanism fails to open or close manually.</p> <p>124. Breech mechanism binds in manual operation</p> <p>125. Breech mechanism fails to operate electrically</p>	<p style="text-align: center;"><b>M81/EI GUN-LAUNCHER-Continued</b></p> <p>d. Defective 120 v power supply.</p> <p>e. IN battery limit switch defective</p> <p>f. Recoil mechanism safe-to-fire switch defective.</p> <p>g. Defective firing circuit relay box</p> <p style="text-align: center;"><b>A short circuit in firing probe or harness may damage K-1 relay in loader's control box. Notify support maintenance if malfunction still occurs.</b></p> <p>a. Defective handcrank assembly.</p> <p>b. Seized breech chamber and/or breech mechanism.</p> <p>a. Breech drive solenoid plunger jammed in locked power position.</p> <p>b. Dirt or foreign material on breech chamber surfaces and/or spindle assembly</p> <p>a. Defective electrical wiring harness.</p> <p>b. Defective electric drive motor.</p> <p>b.</p>	<p>d. Replace 120v power supply (fig. 10-16. 1).</p> <p>e. Replace IN battery limit switch.</p> <p>f. Notify support maintenance.</p> <p>g. Replace relay box (ig. 10-14).</p> <p>a. Notify support maintenance.</p> <p>b. Notify support maintenance.</p> <p>a. Replace spring, plunger, or solenoid, if damaged.</p> <p>b. Clean breech chamber and exposed surface of spindle assembly and apply light coating of lubricating oil MIL-L-46150 (FSN 9150-949-0323)</p> <p>a. Check continuity between electric drive motor plug (P101), solenoid plug (P103), and limit switch plugs (P105 and P106) with large input power receptacle. Replace harness if defective (fig. 11-12).</p> <p>Replace motor (fig. 11-14).</p>



TABLE 8-4. TROUBLESHOOTING - CONTINUED

Malfunction	Probable cause	Corrective action
	<b>GUN-LAUNCHER- Cont</b>	
125. Breech mechanism fails to operate electrically - Continued	<ul style="list-style-type: none"> <li>c. If closed and will not open, breech-open limit switch LS4 (right side) is defective.</li> <li>d. If open and will not close, breech-closed limit switch LS2 (left side) is defective.</li> <li>e. Seized breech chamber and/or breech mechanism.</li> </ul>	<ul style="list-style-type: none"> <li>c. Replace, if defective (fig 11-12).</li> <li>d. Replace, if defective (fig 11-12).</li> <li>e. Notify support maintenance.</li> </ul>
126. Motor runs but breech fails to operate	Defective breech drive solenoid plunger or plunger bushing plunger slides freely. Inspect solenoid for operation. Replace defective components.	Inspect plunger for sheared teeth; bushing to be certain
127. Breech mechanism sluggish in electrical operation	<ul style="list-style-type: none"> <li>a. Insufficient voltage at power source</li> <li>b. Dirt or foreign material on breech chamber surfaces and/or spindle assembly</li> <li>c. Clogged porous vent plug in carrier cover</li> <li>d. Breech mechanism binding</li> </ul>	<ul style="list-style-type: none"> <li>a. Use fully charged batteries or start vehicle engine (1000-1100 rpm) to assure adequate operating voltage</li> <li>b. Clean breech chamber and exposed surface of spindle assembly. Apply light coating of lubricating oil MIL-L-46150 (NSN 9150-00-949-0323)</li> <li>c. Remove vent plug and clean (fig 11-25)</li> <li>d. Notify support maintenance</li> </ul>
- 127. Smoke and/or flame discharging from tube lock key or detent assembly vent	<p>Failure of seal; erosion or corrosion of detent assembly or cannon detent hole</p> <p style="text-align: center;">Type II detent (para 3-3. 4)</p>	<p>Type 1 detent (para 3-3. 4) Remove/install - fig 11-22 Inspect and repair - fig 11-23</p> <p>Remove/install - fig 11-23.1 Disassemble/assemble - 11-23.2 Inspect and repair - fig 11-23.3</p>
128. Ammunition detent does not function	<p>For removal and inspection of Type III detent assembly, notify</p> <ul style="list-style-type: none"> <li>a. Detent release lever set-screw out of adjustment</li> <li>b. Tip of detent worn or broken setscrews (fig 11-23, 23.3)</li> <li>c. Worn or defective actuating mechanism</li> <li>c. Inspect for smooth operation.</li> <li>d. Detent restricted by defective gas seal in breech coupling (MB1 Mod only)</li> </ul>	<p>supporting maintenance</p> <ul style="list-style-type: none"> <li>a. Adjust detent release lever</li> <li>b. Replace detent (fig 11-22, 23. 1)</li> </ul> <p>Replace worn or defective components</p> <ul style="list-style-type: none"> <li>d. Replace seal (fig 11-22)</li> </ul>

TABLE 8-4. TROUBLESHOOTING - CONTINUED

Malfunction	Probable cause	Corrective action
<b>GUN-LAUNCHER-Continued</b>		
128. Ammunition detent does not function - continued	e. Detent release plunger on loading tray seized in detent release position	e. Disassemble loading tray and free up plunger travel in mounting bracket (fig. 11-22).
129. Missile cap ejector mechanism does not operate trigger lever in eject (down) position	a. Ejector not cocked bracket setscrew b. Ejector trigger lever set-screw out of adjustment c. Ejector (finger) not positioned correctly. d. Worn or defective parts in loading tray and ejector group	a. Adjust ejector cocking (fig. 11-21). b. Adjust ejector trigger lever setscrew (fig. 11-21). c. Adjust position (fig. 11-20).
130. Gases accumulate in turret after firing	a. Defective scavenging system.  b. Defective gun tube obturator gasket. c. Defective ammunition detent seals d. Defective check valve: indicated by over-pressure red stem extending beyond outer surface	d. Disassemble loading tray and ejector group and replace worn or defective parts. a. Repair if within scope of organizational maintenance. Otherwise notify support maintenance. b. Replace (fig. 11-24).  c. Notify support maintenance. d. Remove, clean and inspect. If erosion is evident on valve, seal, or sealing surface of tube, notify support maintenance.
<b>CAUTION: Avoid damaging air cylinders, which are under very high pressure.</b>		
130. 1. Smoke and fumes discharging from cover of breech from erosion past firing mechanism.	a. Erosion on breechblock at rear face of seal b. Erosion on firing mechanism.	a. Notify support maintenance. b. Replace firing mechanism.
<b>GUN-LAUNCHER MOUNT</b>		
131. Gun-launcher hangs out of battery.	Defective spring washer set	Notify support maintenance.
132. Rapid loss of precharge pressure in recoil mechanism	a. Defective hydraulic bleed valve or leak in bleed tube or fitting b. Defective check valve in pump-to-recoil mechanism tube or defective hand pump allowing hydraulic fluid to be by-passed to reservoir.	a. Bleed off all pressure and replace check valve, tube, or fitting (fig. 11-7, 8). b. Bleed off all pressure and replace check valve or hand pump (fig. 11-5).

TABLE 8-4. TROUBLESHOOTING - CONTINUED

Malfunction	Probable cause	Corrective action
	<b>GUN-LAUNCHER MOUNT Continued</b>	
133. Difficult to adjust precharge pressure in recoil mechanism.	Defective hand pump replace hand pump (fig. 11-5).	Bleed off all pressure and
134. Gun-launcher recoils with excessive force	a. Insufficient fluid in recoil mechanism due to defective safe-to-fire indicator. b. Air in recoil mechanism	a. Notify support maintenance.  b. Open bleed valve and bleed off all pressure, and then readjust recoil mechanism pressure (fig. 3-2).
135. Gun-launcher returns to battery with excessive force.	Insufficient fluid in or defective buffer	Fill buffer (fig. 5-9) or replace (fig. 11-2).
	<b>SIGHTING AND FIRE CONTROL INSTRUMENTS PERISCOPE XM44 SERIES</b>	
136. Loss of boresight	a. Head assembly not properly seated  b. Body assembly not seated properly  c. Boresight knobs not fully engaged	a. Remove head assembly and reinstall (fig. 11-41).  b. Remove body assembly and check for foreign matter around locating keys and keyways and for burred or broken locating keys.  c. Check knobs to insure firm engagement with clutch teeth.
137. Flickering image at screen of image intensifier tube after stabilization period	a. Reticle lamp Or rheostat failure  b. Loose or poor electrical connection	a. Replace lamp. Refer to support maintenance to replace rheostat.  b. Check and tighten electrical connections.
137.1. Inability to focus	Image intensifier tube with related parts improperly assembled/installed.	Notify support maintenance.
138. Gun and periscope not synchronized	Link assembly loose	Synchronize and tighten link adjustment (Fig. 11-43).

TABLE 8-4. TROUBLESHOOTING - CONTINUED

Malfunction	Probable cause	Corrective action
<p>138. 1. Condensation or fogging, XM44E Series only</p> <p>139. Elevation micrometer and knob will not turn</p> <p>140. Index travels beyond scale limits.</p> <p>141. Excessive backlash.</p> <p>142. Depression and elevation errors</p> <p>143. Level bubble out of adjustment.</p> <p>144. Poor visibility</p> <p>145. Wiper blades smear prisms.</p>	<p style="text-align: center;"><b>SIGHTING AND FIRE-CONTROL INSTRUMENTS-CONTINUED</b> <b>PERISCOPE XM44 SERIES-CONTINUED</b></p> <p>Moisture in head and/or body due to loss of nitrogen pressure.</p> <p><b>NOTE. For any malfunctions not listed, notify support maintenance. TELESCOPE, ARTICULATED, M119 OR M127 MOUNT, TELESCOPE M149 INDICATOR, AZIMUTH 10954720</b></p> <p><b>NOTE. For any malfunction of telescope, telescope mount, or azimuth indicator, notify support maintenance. QUADRANT (ELEVATION) M13A1C</b></p> <p>a. Worm plunger too tight</p> <p>b. Elevating worm bent</p> <p>Stops out of mounting groove</p> <p>a. Worn gears</p> <p>b. Loose or worn plunger</p> <p>c. Broken spring</p> <p>a. Poorly spaced worm or worm gear teeth.</p> <p>Bubble improperly adjusted</p> <p style="text-align: center;"><b>PERISCOPES M47 AND M48</b></p> <p>a. Condensation</p> <p>b. Dirty prisms</p> <p>Worn wiper blade</p>	<p>Purge, leak test, and pressurize (TM 750-116).</p> <p>a. Replace quadrant (fig. 11-39).</p> <p>b. Replace quadrant.</p> <p>Replace quadrant.</p> <p>a. Replace quadrant</p> <p>b. Replace quadrant.</p> <p>c. Replace quadrant.</p> <p>a. Replace quadrant.</p> <p>Replace quadrant.</p> <p>a. Refer to TM 750-116.</p> <p>b. Clean.</p> <p>Replace blade Rig. 11-42)</p>

TABLE 8-4. TROUBLESHOOTING - CONTINUED

Malfunction	Probable cause	Corrective action
<p>146. Wiper motor does not operate.</p> <p>147. No cleaning fluid from washer assembly</p> <p>148. Periscope loose after installation.</p> <p>149. No infrared vision</p>	<p style="text-align: center;"><b>SIGHTING AND FIRE-CONTROL INSTRUMENTS - CONTINUED PERISCOPE M47 AND M48</b></p> <p>a. Defective switch</p> <p>b. Faulty wiring or connections.</p> <p>a. No fluid in reservoir</p> <p>b. Faulty pump</p> <p>c. Clogged tubing</p> <p>d. Clogged check valve</p> <p>e. Loose tubing connection or leaking tubing</p> <p>a. Faulty catches</p> <p>b. Loose mount assembly</p> <p>c. Worn seal</p> <p>Improper electrical ground</p>	<p>a. Replace switch (fig. 9-101).</p> <p>b. Repair or replace faulty components.</p> <p>a. Refill reservoir (fig. 11-37).</p> <p>b. Replace pump.</p> <p>c. Clean tubing or nozzle.</p> <p>d. Clean check valve.</p> <p>e. Replace defective tubing or connectors.</p> <p>a. Notify support maintenance.</p> <p>b. Tighten bolts (fig. 11-36).</p> <p>c. Replace seal (fig. 11-36).</p> <p>Clean all mating ground surfaces between mount, hatch, body and head.</p>

TABLE 8-5. OHMMETER METHOD OF ELECTRICAL TROUBLESHOOTING

a. **General.** The ohmmeter method of electrical troubleshooting (fig. 8-2) uses continuity tests to determine whether circuit or device being tested has a continuous electrical path through cables and unit connected between two test points. An ohmmeter indicates, on a calibrated scale, resistance of circuit being tested and is equipped with a power source (battery or hand generator), usually installed inside case which houses

the meter. All electrical circuits have some resistance. Resistances may be so low, or high, they cannot be read with an ordinary ohmmeter. An ohmmeter with a full-scale reading of 10 ohms is desirable for measuring low resistances. Higher range ohmmeters are better suited for testing insulation leaks. If the normal resistance of circuit to be tested is known, select an ohmmeter with a full-scale range higher than normal resistance.

TABLE 8-5. OHMMETER METHOD OF ELECTRICAL TROUBLESHOOTING - CONTINUED

**CAUTION Never attempt to make ohmmeter tests until all sources of power connected to equipment to be tested are disconnected. The ohmmeter will be damaged if this procedure is not followed.**

b. Continuity Tests. Place prods or clips from ohmmeter on end points of circuit to be tested, or to two terminals at which ends of component to be tested terminate. If a normal reading is obtained, circuit has no breaks or openings.

c. Resistance Reading. A resistance reading is taken to determine electrical condition of a coil, resistor, capacitor, or complete circuit. When correct resistance of a unit is known, a resistance test will indicate if there is a fault in circuit.

d. Infinity and Zero Ohmmeter Readings.

(1) Infinity reading. An infinity reading indicates that no path exists for current flow in a component, or that an open circuit exists. The ohmmeter indicator does not move when infinite resistance exists but remains at a point on ohmmeter scale usually marked by symbol "∞" or abbreviation "INF" An ohmmeter should always give an infinity reading when test leads are disconnected.

(2) Zero reading. A zero ohmmeter reading indicates closed circuit with no measurable resistance. When a known resistance is specified and a zero reading is obtained, a short circuit exists within component or circuit being tested. An ohmmeter should always be adjusted to give a zero reading when test prods or clips are touched together.

e. Test Point Designation. Ohmmeter test points are tabulated for each electrical circuit and referenced to an accompanying illustration. The letter "P" denotes testpoint (terminal, plug, or receptacle) and is followed by a number designating the test point numerical sequence. Multi-plug and receptacle designation are also followed by a letter to indicate the specific pin or socket. P1-A then will denote test point "1," pin "A." Ground (gnd) means any part of vehicle that has a good electrical connection with the unit being tested. Electrical circuits and tables are as follows:

Figure 8-3. Troubleshooting Master Relay and Battery Power Circuits

Figure 8-4. Troubleshooting Generator and Voltage Regulator Circuits

Figure 8-5. Troubleshooting Engine Starter Circuit

Figure 8-6. Troubleshooting Flame Heater Circuits

Figure 8-7. Troubleshooting Indicator Panel Circuits

Figure 8-8. Troubleshooting Fuel Level Indicator Circuits

Figure 8-9. Troubleshooting Driver's Periscope Wiper Circuits

Figure 8-10. Troubleshooting Bilge Pump Circuits

Figure 8-11. Troubleshooting Personnel Heater Circuits

Figure 8-12. Troubleshooting Power Plant Indicator and Warning Light Circuits

Figure 8-13. Troubleshooting Vehicle Driving Light Circuits.

Figure 8-13.1. Tachometer/Speedometer/ Odometer  
f. Generator Regulator Performance Test.

Refer to Figure 8-4.

**A - DC VOLTAGE TEST**

- (1) BE SURE OF WHAT TEST YOU ARE MAKING.
- (2) SELECT A VOLTAGE RANGE HIGHER THAN THE EXPECTED READING.
- (3) SELECT THE DC SCALE ON THE METER.
- (4) CONNECT THE NEGATIVE (MARKED OR COLORED BLACK) LEAD FIRST.
- (5) TOUCH POSITIVE (MARKED OR COLORED RED) LEAD AND OBSERVE NEEDLE FOR CORRECT MOVEMENT PRIOR TO CLIPPING.
- (6) DC VOLTAGE TEST IS MADE TO MEASURE BATTERY, GENERATOR, OR SIGNAL VOLTAGES.

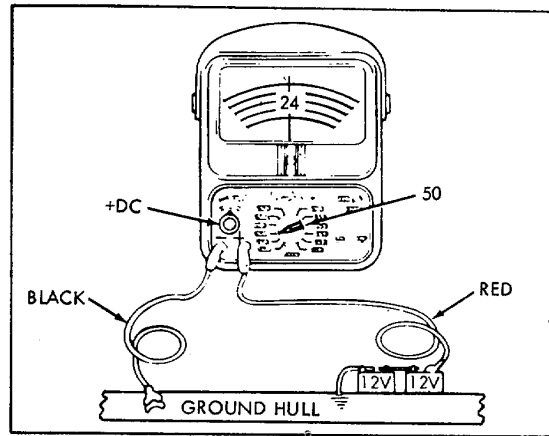

A - DC VOLTAGE TEST

**B - RESISTANCE TEST**

- (1) BE SURE OF WHAT TEST YOU ARE MAKING.
- (2) PLACE THE VEHICLE MASTER SWITCH IN THE "OFF" POSITION.
- (3) SELECT THE DESIRED RESISTANCE RANGE.
- (4) TOUCH LEADS TOGETHER AND ADJUST TO "0" NEEDLE POSITION.
- (5) RESISTANCE TEST IS MADE TO MEASURE RESISTANCE OR OHMIC VALUES OF COILS AND RESISTORS AS GIVEN IN TEST PROCEDURES.

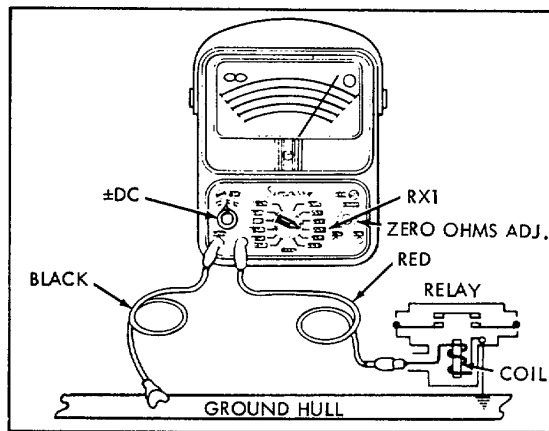

B - RESISTANCE TEST

**C - CONTINUITY TEST**

- (1) BE SURE OF WHAT TEST YOU ARE MAKING.
- (2) PLACE THE VEHICLE MASTER SWITCH IN THE "OFF" POSITION.
- (3) SELECT THE RX1 SCALE.
- (4) CONTINUITY TEST IS USED TO CHECK IF A WIRE OR CONNECTOR IS IN GOOD CONDITION. AN "0" READING INDICATES A GOOD CABLE, SUCH AS SHOWN. A HIGH RESISTANCE READING OR NO NEEDLE MOVEMENT MAY INDICATE AN OPEN CIRCUIT, DAMAGED CABLE, OR POOR SOLDER JOINT.

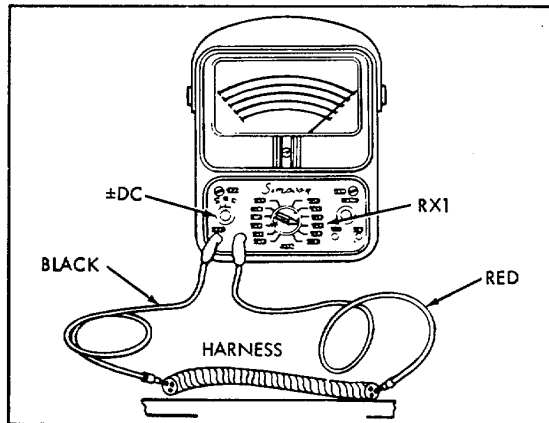

C - CONTINUITY TEST

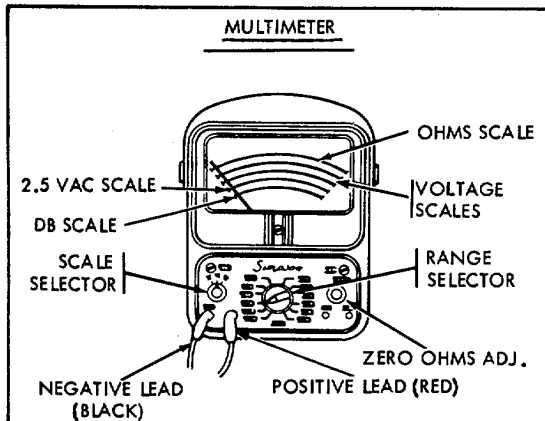

AUTHORIZED TEST EQUIPMENT MULTIMETER - 6625-553-0142

WE 66613

Figure 8-2. Troubleshooting hull and power plant electrical system with multimeter

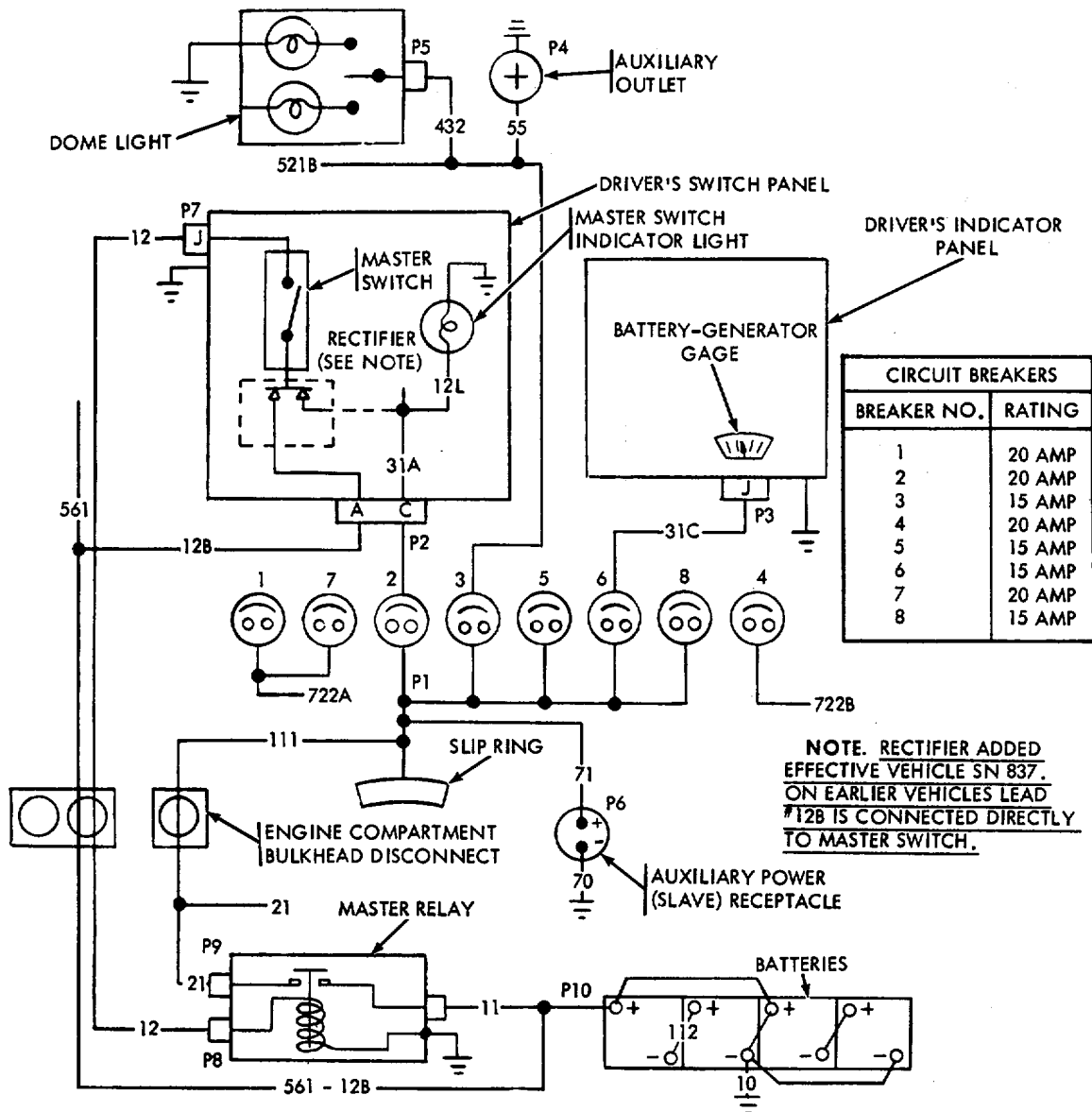

**DESCRIPTION**

MASTER RELAY AND BATTERY POWER CIRCUITS CONSIST OF 4 BATTERIES (2 IN SOME EARLY VEHICLES), MASTER SWITCH AND INDICATOR LIGHT, MASTER RELAY, BATTERY/GENERATOR GAGE, AND RECTIFIER (VEHICLES AFTER SN 836). RECTIFIER PERMITS SLAVE CHARGING OF VEHICLE BATTERIES, PROTECTS VOLTAGE REGULATOR AND BATTERIES (BUT NOT TURRET COMPONENTS) AGAINST REVERSE POLARITY OF SLAVE SOURCE, AND PROTECTS ALL COMPONENTS AGAINST REVERSE POLARITY OF VEHICLE BATTERIES. CIRCUITS ARE ENERGIZED AS FOLLOWS:

(1) POWER IS FED DIRECTLY FROM BATTERIES TO MASTER SWITCH, POWER TERMINAL OF MASTER RELAY, PERSONNEL HEATER CONTROL BOX, AND WINTERIZATION KIT CONTROL BOX (IF INSTALLED).

- (2) WHEN MASTER SWITCH IS CLOSED, MASTER RELAY IS ENERGIZED, FEEDING POWER TO TURRET SLIP RING DIRECTLY AND THROUGH CIRCUIT BREAKERS TO ALL HULL COMPONENTS AND SLAVE RECEPTACLE.
- (3) POWER FED TO BATTERY/GENERATOR GAGE INDICATES CONDITION OF BATTERIES (ENGINE OFF) OR OPERATION OF GENERATOR SYSTEM (ENGINE ON).
- (4) WITH RECTIFIER, SLAVE POWER CAN BE FED THROUGH MASTER SWITCH TO MASTER RELAY PULL-IN COIL, COMPLETING CIRCUIT FROM SLAVE SOURCE TO BATTERIES FOR CHARGING.

WE 66621

Figure 8-3. Troubleshooting-master relay and battery power circuits

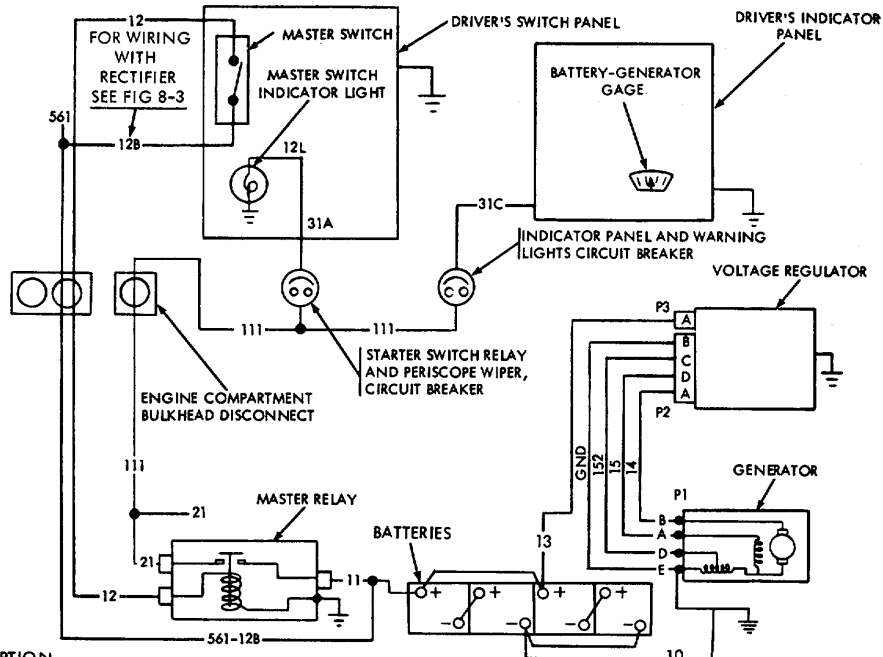

TABLE 8-6. MASTER RELAY AND BATTERY POWER CIRCUITS (FIG. 8-3)

COMPONENT	CIRCUIT NUMBER	TEST POINTS		RESISTANCE (ohms)	CIRCUIT	REMARKS
		FROM	TO			
<b>CAUTION:</b> Disconnect battery positive and negative cables before making resistance or continuity tests.						
Master switch lead	12B	P10	P2-A	0	From battery to switch panel	Infinity indicates open circuit or defective lead.
Master switch (without rectifier)		P2-A	P7-J	0 OR INF	Through panel and master switch	Switch "off": Zero OHMS indicates defective switch Switch "on": Any resistance indicates defective switch.
Master switch (with rectifier)		P2-A	P7-J	(Checks like diode)	Through rectifier and master switch	Switch "off": Reading other than infinity indicates defective switch. Switch "on": (Ohmmeter on X1 scale): Reversing probes should give high and low resistance readings. Both readings low indicates defective rectifier. Both readings high indicates defective switch and/or defective rectifier.
		P2-C	P7-J	(Checks like diode)	Same as above	Same as above.
Master switch to relay lead	12	P7-J	P8	0	From switch panel to relay	Infinity indicates open circuit or defective lead.
Relay coil		P8	CASE	58	Through relay coil to ground	Infinity or zero OHMS indicates defective coil.
Relay contacts		P9	P10	INF	Through contacts	Zero OHMS indicates defective relay.
System main feed lead	21, 111 21,111, 71	P9 P9	P1 P6	0	Relay to circuit breakers and slave receptacle	Infinity indicates open circuit or defective lead.
Master switch indicator light feed	31A	P1	P2-C	0	Through circuit breaker to switch panel	Infinity indicates open circuit or defective lead.

TABLE 8-6. MASTER RELAY AND BATTERY POWER CIRCUITS-CONTINUED

COMPONENT	CIRCUIT NUMBER	TEST POINTS		RESISTANCE (ohms)	CIRCUIT	REMARKS
		FROM	TO			
Master switch indicator light	12L	P2-C	GND	170-210	Through panel and light bulb	Infinity indicates open circuit, defective lead or burned out bulb. Zero OHMS indicates short circuit.
Indicator panel feed lead	31C	P1	P3-J	0	Through circuit breaker to indicator panel	Infinity indicates open circuit or defective lead.
Auxiliary outlet feed	55	P1	P4	0	Through circuit breaker to auxiliary outlet	Infinity indicates open circuit or defective lead.
Dome light feed	432	P1	P5	0	Through circuit breaker to dome light	Infinity indicates open circuit or defective lead.
Dome light red side	-	P5	CASE	18	Circuit through light switch and bulb	Switch lever toward red lens. Infinity indicates open circuit, defective lead, defective switch or burned out bulb. Zero OHMS indicates short circuit.
Dome light white side	-	P5	CASE	5.5	Circuit through light switch and bulb	Switch lever moved past guard. Infinity indicates open circuit, defective lead, defective switch, or burned out bulb. Zero OHMS indicates short circuit.

**DESCRIPTION**

THE GENERATING CIRCUIT CONSISTS OF A GENERATOR, VOLTAGE REGULATOR, AND BATTERY-GENERATOR GAGE AND IS ENERGIZED AS FOLLOWS:

1. ENGINE RPM DRIVES GENERATOR WHICH GENERATES A SMALL AMOUNT OF POWER WHICH IS FED THROUGH THE VOLTAGE REGULATOR AND BACK TO EXCITE GENERATOR FIELD. THIS CYCLE CONTINUES UNTIL THE VOLTAGE REGULATOR LIMITS THE POWER SUPPLIED TO THE GENERATOR FIELD, THEREBY REGULATING THE GENERATOR OUTPUT VOLTAGE.
2. REGULATED VOLTAGE IS FED FROM THE GENERATOR, THROUGH THE VOLTAGE REGULATOR TO CHARGE BATTERIES.
3. WITH MASTER RELAY ENERGIZED, BATTERIES AND GENERATOR SUPPLY POWER TO OPERATE VEHICLE ELECTRICAL COMPONENTS.

4. POWER IS FED THROUGH A 15 AMP CIRCUIT BREAKER THROUGH BATTERY-GENERATOR GAGE TO GROUND, WHICH GIVES READINGS PERTAINING TO SYSTEM VOLTAGE.
5. TESTING AND ADJUSTMENT. PERFORM OHMMETER TESTS (TABLE 8-7) TO PINPOINT DEFECTIVE CIRCUIT COMPONENTS. ADJUST REGULATOR ACCORDING TO INSTRUCTIONS GIVEN IN FIGURE 9-110. AS AN ADDITIONAL TEST FOR PROPER OPERATION, SYSTEM VOLTAGE MEASURED AT THE BATTERIES OR GENERATOR SHOULD NOT VARY MORE THAN 0.5 VOLT FROM INITIAL SETTING WHEN ENGINE SPEED IS VARIED FROM 1000 TO 2800 R.P.M. WITH CONSTANT VEHICLE LOAD APPLIED, I.E., HEADLIGHTS AND/OR BILGE PUMPS, TURRET FAN ETC.

**NOTE.** LOAD SHOULD NOT EXCEED 300 AMPERES.

**VOLTAGE REGULATOR FAILSAFE CIRCUIT (LOCKOUT)**

(NOT ALL GENERATOR SYSTEM FAILURES INVOLVE LOCKOUT).

VOLTAGE REGULATOR FAILSAFE LOCKOUT PREVENTS DAMAGINGLY HIGH GENERATOR OUTPUT WHICH COULD RESULT FROM:

POOR CONNECTION IN GROUND CIRCUIT OF GENERATOR-TO-REGULATOR HARNESS.  
CERTAIN CIRCUITRY FAILURES IN GENERATOR OR REGULATOR.

FAILSAFE LOCKOUT OPENS GENERATOR FIELD, MAKING SYSTEM VOLTAGE ENTIRELY DEPENDENT ON BATTERIES.

WITH ENGINE OFF, CHECK FOR LOCKOUT BY MOMENTARILY DISCONNECTING BATTERY-TO-VOLTAGE REGULATOR CABLE (CIRCUIT # 13) TO RESET REGULATOR. IF SYSTEM IS STILL INOPERATIVE OR IF REPEATED LOCKOUT OCCURS, AND NO HARNESS FAULT CAN BE FOUND, REPLACE REGULATOR. IF STILL INOPERATIVE, REPLACE GENERATOR.

WE 66622

Figure 8-4. Troubleshooting-generator and voltage regulator circuits

8-50.2 (8-50.1 Blank)

TABLE 8-7. GENERATOR AND VOLTAGE REGULATOR CIRCUITS (FIG. 8-4)

COMPONENT	CIRCUIT NUMBER	TEST POINTS		RESISTANCE (ohms)	CIRCUIT	REMARKS
		FROM	TO			
<p><b>CAUTION:</b> <u>Disconnect battery positive and negative cables before making resistance or continuity tests.</u></p> <p><b>NOTE.</b> <u>See Troubleshooting (table 8-4, items 41 through 43) before performing ohmeter tests.</u></p>						
Generator and generator-to-voltage regulator harness (harness disconnected at voltage regulator)  <u>NOTE Check pin alignment. Harness must be flexed during ohmeter check to detect intermittent circuits.</u>	14/GND	P2A	P2B	0.05 to 0.10	P2A through harness leads, generator brushes, armature, series field, to P2B.	Zero or high resistance indicates faulty circuit.
	15/GND	P2D	P2B	2.0 to 2.5	P2D through harness leads, generator shunt field, series field to P2B.	Improper resistance indicates faulty circuit.
	152/GND	P2C	P2B	0	P2C through harness leads, generator series field to P2B.	Any resistance indicates faulty circuit.
	GND	Hull Ground	P2B	0	Hull ground through generator ground lead through harness GND lead to P2B.	Any resistance indicates faulty circuit.
<p>If all above tests give readings within limits shown, omit generator tests below. If any of above tests indicates a faulty circuit, perform generator tests below to isolate fault in either generator or harness.</p>						
Generator (harness disconnected at voltage regulator. Refer to figure 9-111 for terminal identification).		P1B	P1E (GND)	0.05 to 0.10	P1B through generator armature, brushes, series field to P1E	Resistances shown are proper, but generator may function with resistances as high as 5.0 ohms.
		P1A	P1E (GND)	2.0 to 2.5	P1A through generator shunt field, series field to P1E.	Improper resistance indicates faulty generator.
		P1D	P1E (GND)	0	P1D through part of interpole winding to ground.	Any resistance indicates a faulty generator.
<p>Generator may show proper resistances and still be defective. Replace generator only after eliminating all other possible sources of trouble.</p>						
Regulator-to-battery harness	13	P3A	P4	0	P3A through lead to P4	Any resistance indicates faulty lead.
Voltage Regulator		P2A	P3A	--		Zero indicates fused relay in voltage regulator (Replace regulator).
<p><b>NOTE.</b> <u>Other voltage regulator defects cannot be isolated by ohmeter test.</u></p>						

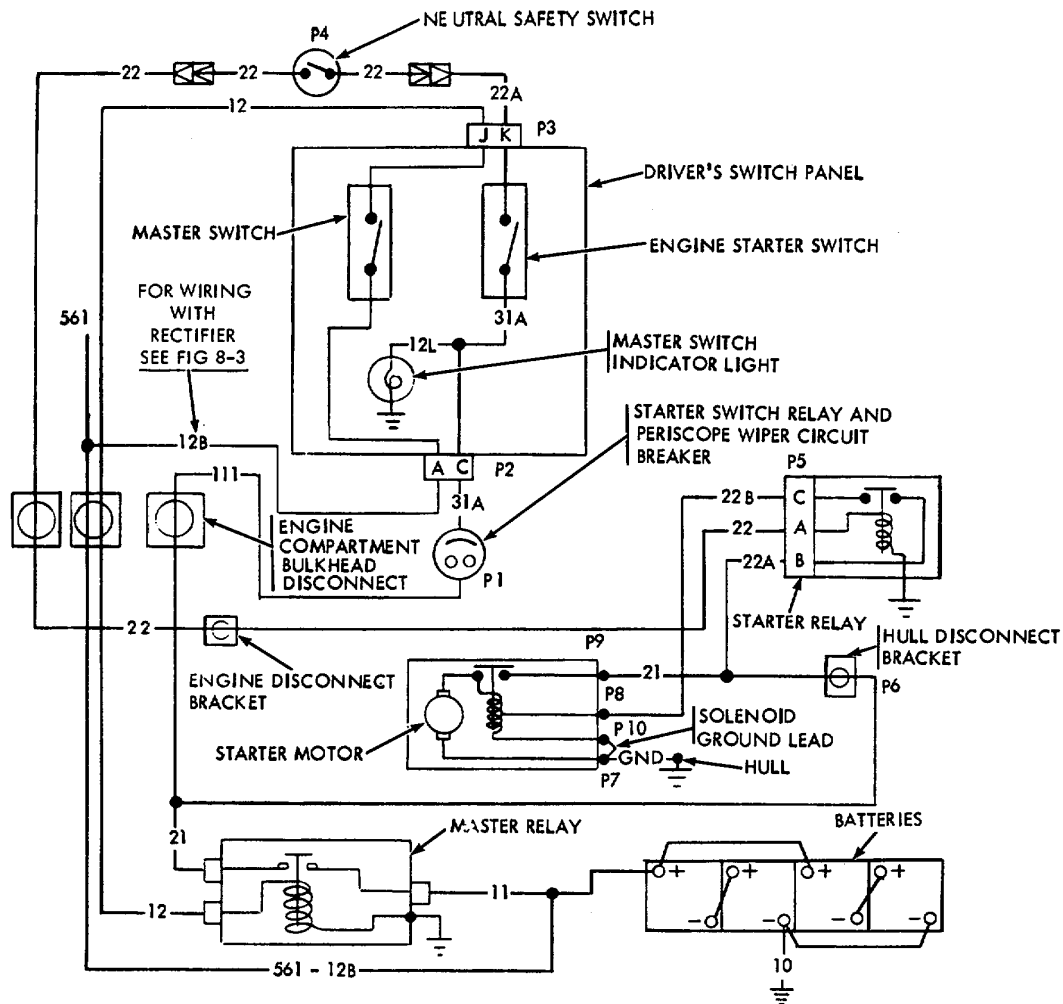

#### DESCRIPTION

THE ENGINE STARTER CIRCUIT CONSISTS OF A 20 AMP CIRCUIT BREAKER, NEUTRAL SAFETY SWITCH, STARTER RELAY, AND STARTER AND SOLENOID. THE CIRCUIT IS ENERGIZED AS FOLLOWS:

- (1) WHEN MASTER SWITCH IS CLOSED THE MASTER RELAY IS ENERGIZED. POWER IS FED FROM MASTER RELAY THROUGH 20 AMP CIRCUIT BREAKER, TO STARTER SWITCH.
- (2) WHEN STARTER SWITCH IS CLOSED, POWER IS FED THROUGH NEUTRAL SAFETY SWITCH AND STARTER RELAY COIL TO GROUND, ENERGIZING STARTER RELAY.
- (3) WITH STARTER RELAY ENERGIZED, POWER IS FED FROM MASTER RELAY THROUGH STARTER RELAY TO STARTER SOLENOID COIL TO GROUND, ENERGIZING STARTER SOLENOID.
- (4) WITH STARTER SOLENOID ENERGIZED, POWER IS FED FROM MASTER RELAY THROUGH STARTER SOLENOID, ENERGIZING STARTER.

WE 66623

Figure 8-5. Troubleshooting-engine starter circuit

TABLE 8-8. ENGINE STARTER CIRCUITS (FIG. 8-5)

COMPONENT	CIRCUIT NUMBER	TEST POINTS		RESISTANCE (ohms)	CIRCUIT	REMARKS
		FROM	TO			
<b>CAUTION:</b> Disconnect battery positive and negative cables before making resistance or continuity tests.						
Circuit breaker	31A	P1	P2-C	0	Lead through circuit breaker	Any reading greater than zero OHMS indicates a defective circuit breaker.
Starter switch	31A 22A	P2-C	P3-K	0 OR INF	P2 through starter switch to P3	Zero OHMS with switch in "start" position; infinity with switch in "off" position.
Neutral safety switch	22	P4	P4	0 OR INF	P4 through neutral safety switch to P4	Zero OHMS with shift lever in neutral; infinity with lever in any other position.
Starter relay	22	P4	GND	70-180	P4 through harness leads, starter relay coil, to ground	Zero or infinity indicates defective harness or starter relay.
		P5-A	GND	70-180	P5-A through starter relay coil to ground	Zero or infinity indicates defective starter relay.
		P5-B	P5-C	INF	P5-B through normally open contacts to P5-C	Any resistance reading indicates defective starter relay.
Starter relay power lead	22A	P5-B	P6	0	P5-B through harness to P6	Any resistance reading indicates defective harness.
Starter solenoid energizing lead	22B	P5-C	P8	0	P5-C through harness to P8	Any resistance reading indicates defective harness.
Starter solenoid pull-in coil and starter motor (solenoid ground lead disconnected)		P7	P8	.5 - .6	P7 through starter motor solenoid pull-in coil to P8	Zero or infinity indicates defective starter solenoid or starter motor.
Starter solenoid hold-in coil (solenoid ground lead disconnected)		P8	P10	3.1	P8 through starter motor solenoid hold-in coil to P10	Zero or infinity indicates defective starter solenoid.
Starter solenoid relay		P9	P7	INF	P9 through normally open starter solenoid relay. Starter motor armature to P7	Any resistance reading indicates faulty relay.
Starter motor		P7 P8 P9 P10	GND	More than 500,000	P7, P8, P9, P10, to starter frame	Any low resistance reading indicates faulty starter.

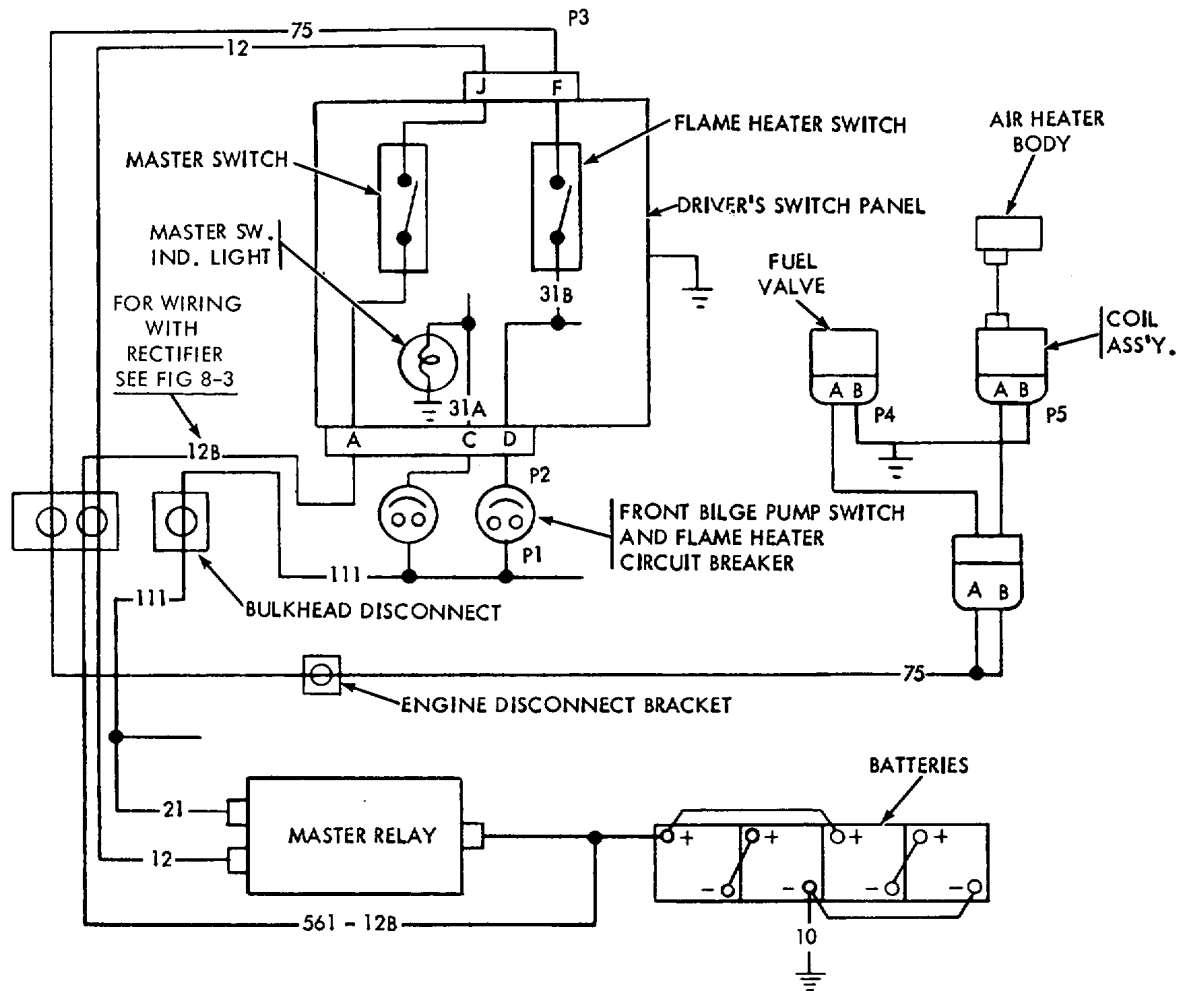

#### DESCRIPTION

THE FLAME HEATER CIRCUIT CONSISTS OF A 15 AMP CIRCUIT BREAKER, FLAME HEATER SWITCH, FUEL VALVE AND COIL ASSEMBLY AND IS ENERGIZED AS FOLLOWS:

1. WHEN THE MASTER RELAY IS ENERGIZED BY TURNING THE MASTER SWITCH "ON", POWER IS FED FROM THE MASTER RELAY THROUGH THE FRONT BILGE PUMP SWITCH AND FLAME HEATER CIRCUIT BREAKER TO THE FLAME HEATER SWITCH.
2. WITH THE FLAME HEATER SWITCH ON, POWER IS FED TO THE FUEL VALVE AND COIL ASSEMBLY.

WE 66624

Figure 8-6. Troubleshooting-flame heater circuits

TABLE 8-9. FLAME HEATER CIRCUITS (FIG. 8-6)

COMPONENT	CIRCUIT NUMBER	TEST POINTS		RESISTANCE (ohms)	CIRCUIT	REMARKS
		FROM	TO			
CAUTION: Disconnect battery positive and negative cables before making resistance or continuity tests.						
Flame heater feed	31B	P1	P2-D	0	Through circuit breaker to panel	Infinity indicates open circuit or defective lead.
Flame heater switch		P2-D	P3-F	0 OR INF	Through panel and switch	Infinity with switch "off". Zero OHMS with switch "ON". Any resistance in-between indicates defective switch.
Flame heater lead	75	P3-F	P4-A	0	From switch panel to valve and coil assembly connections	Infinity indicates open circuit or defective lead.
	75	P3-F	P5-A			
Fuel valve ground lead		P4-B	GND	0	Fuel valve to ground	Infinity indicates open circuit or defective lead.
Coil assembly ground lead	GND	P5-B	GND	0	Coil assembly to ground	Infinity indicates open circuit or defective lead.
Fuel valve		P4-A	P4-B	26-27	Through fuel valve	Infinity or zero OHMS indicates defective valve.
Coil assembly		P5-A	P5-B	.85 - .91	Through coil assembly	Zero OHMS or infinity indicates defective coil assembly.



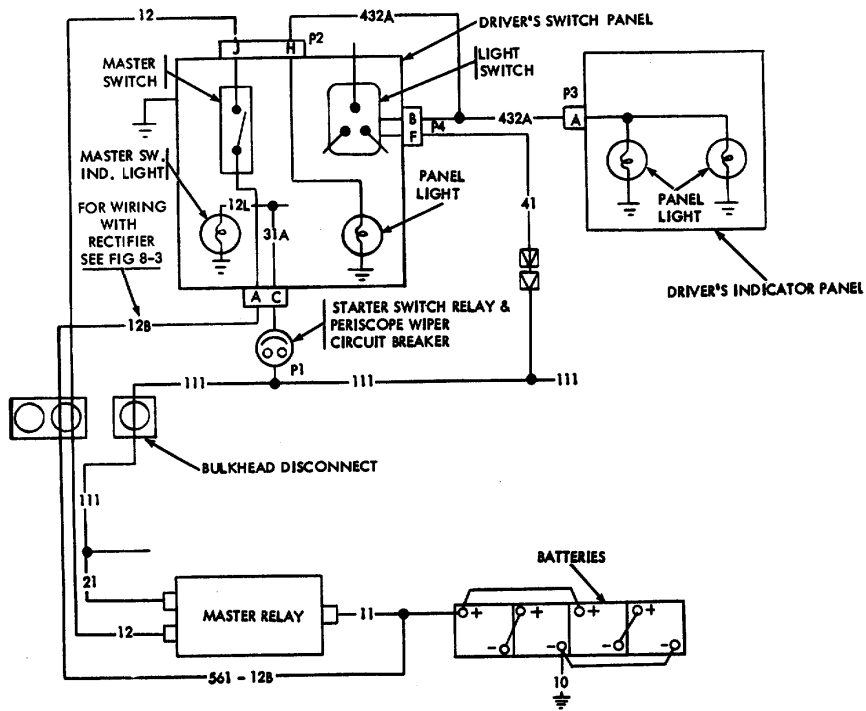

**DESCRIPTION**

THE INDICATOR PANEL LIGHT CIRCUIT CONSISTS OF THE MAIN LIGHT SWITCH AND THREE PANEL LIGHTS.

WHEN THE MASTER RELAY IS ENERGIZED BY TURNING THE MASTER SWITCH ON, POWER IS FED FROM THE MASTER RELAY TO THE LIGHT SWITCH, OPERATION OF THE PANEL LIGHT LEVER IN THE LIGHT SWITCH WILL FEED POWER TO THE PANEL LIGHTS.

WE 66625

Figure 8-7. Troubleshooting-indicator panel light circuits

TABLE 8-10. INDICATOR PANEL LIGHT CIRCUITS (FIG. 8-7)

COMPONENT	CIRCUIT NUMBER	TEST POINTS		RESISTANCE (ohms)	CIRCUIT	REMARKS
		FROM	TO			
<b>CAUTION:</b> Disconnect battery positive and negative cables before making resistance or continuity tests.						
Main light switch feed	41	P1	P4-F	0	Light switch feed	Infinity indicates open circuit or defective lead.
Switch internal circuit for panel lights lever in "dim" position		P4-F	P4-B	28-31	Switch internal circuit including dimming resistor	Main lever in service drive position. Infinity or zero OHMS indicates defective switch.
Lever in "bright" position		P4-F	P4-B	0	Switch internal circuit	Main lever in service drive position. Infinity or resistance reading indicates defective switch.
Panel lights leads	432A	P4-B	P2-H P3-A	0	Panel light switch to switch panel and indicator panel lead	Infinity indicates open circuit or defective lead.
Panel light in switch panel		P2-H	GND	170-210	Through switch panel and light bulb	Infinity indicates open circuit, defective lead or burned out bulb. Zero OHMS indicates short circuit.
Panel lights in indicator panel	432A	P3-A	CASE	170-210	Circuit through indicator panel and light bulbs	Remove one panel light and filter assembly before test. Infinity indicates open circuit, defective lead or burned out bulb. Zero OHMS indicates short circuit. Replace panel light and filter and remove other panel light and filter. Recheck.

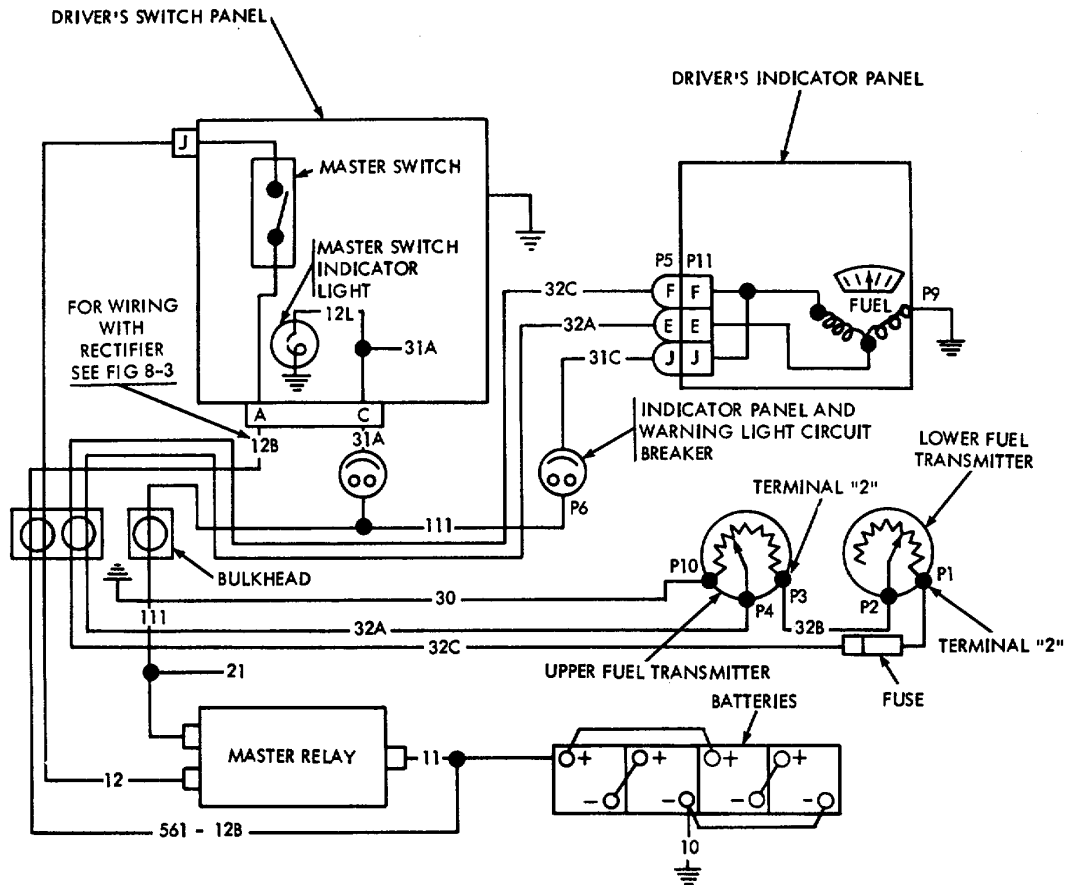
**DESCRIPTION:**

THE FUEL LEVEL INDICATOR CIRCUIT CONSISTS OF A 15 AMP CIRCUIT BREAKER, FUEL LEVEL INDICATOR, FUSE, LOWER FUEL LEVEL TRANSMITTER, AND UPPER FUEL LEVEL TRANSMITTER. THE CIRCUIT IS ENERGIZED AS FOLLOWS:

1. WHEN THE MASTER RELAY IS ENERGIZED BY TURNING ON THE MASTER SWITCH, CURRENT FLOWS FROM THE MASTER RELAY THROUGH THE CIRCUIT BREAKER TO THE FUEL LEVEL INDICATOR IN THE DRIVER'S INDICATOR PANEL, THEN FROM THE DRIVER'S INDICATOR PANEL THROUGH THE FUSE TO THE LOWER FUEL TANK TRANSMITTER, FROM THE LOWER FUEL TANK TRANSMITTER TO THE UPPER FUEL TANK TRANSMITTER AND RETURNS TO THE DRIVER'S INDICATOR PANEL.
2. EACH TRANSMITTER IS ACTUATED BY FUEL LEVEL IN RESPECTIVE TANKS AND VARIES RESISTANCE IN THE CIRCUIT, GIVING A DIRECT READING ON THE FUEL LEVEL INDICATOR COMPATIBLE WITH THE TOTAL QUANTITY OF REMAINING FUEL.

WE 66626

Figure 8-8. Troubleshooting - fuel level indicator circuits

TABLE 8-11. FUEL LEVEL INDICATOR CIRCUITS (FIG. 8-8)

**CAUTION:** Disconnect battery positive and negative cables before making tests.

**NOTE.** Tanks must have at least 36 gallons of total fuel for purposes of these tests. Upper tank valves must be open.

COMPONENT	CIRCUIT NUMBER	TEST POINTS		RESISTANCE (ohms)	CIRCUIT	REMARKS
		FROM	TO			
Power circuit to panel	31C	P6	P5J	0	Through circuit breaker to panel	Infinity indicates open circuit breaker or defective lead.
Power circuit to transmitters	32C	P5F	P1	0	Panel to lower transmitter	Infinity indicates open circuit, defective lead or blown fuse.
Power circuit in panel	---	P11J	P11F	0	Through jumper in panel	Resistance indicates defective panel.
Fuel level indicator	---	P11E	P9	350	Through indicator to ground	Infinity indicates open circuit in panel.
Fuel level indicator	---	P11E	P11F	350	Through indicator to ground	Infinity indicates open circuit in panel.
Mounting bracket	---	PANEL	HULL	0	Mount ground lead	Infinity indicates open ground lead.
Upper transmitter to panel lead	32A	P4	P5E	0	Upper transmitter to indicator panel	Infinity indicates open circuit or defective lead.
Lower transmitter	---	P1	P2	45	Through lower transmitter	Zero resistance indicates lost float.
Upper transmitter	---	P3	P10	385	Through upper transmitter	Low resistance indicates shorted transmitter resistor. Infinity indicates open resistor.
Upper Transmitter	-- (a)	P3	P4	5-385	Through part of transmitter resistor	Resistance varies from zero OHMS at empty to 385 OHMS at full. Zero OHMS indicates lost float.
	-- (b)	P4	P10	0-385	Balance of resistor	Total resistance, (a) + (b) should equal approximately 385 OHMS. Low total resistance indicates shorted resistor.
Transmitter ground circuit	30	P10	HULL ground	0	Through circuit #30 to ground	Resistance indicates poor ground connection to bulkhead. Infinity indicates open ground circuit.
Transmitter interconnector	32B	P2	P3	0	Lower transmitter to upper transmitter	Infinity indicates open circuit or defective lead.
Transmitters	---	P1	P10	Infinity	Through lower transmitter resistor to ground,	Reading other than infinity indicates lower transmitter resistor is shorted.

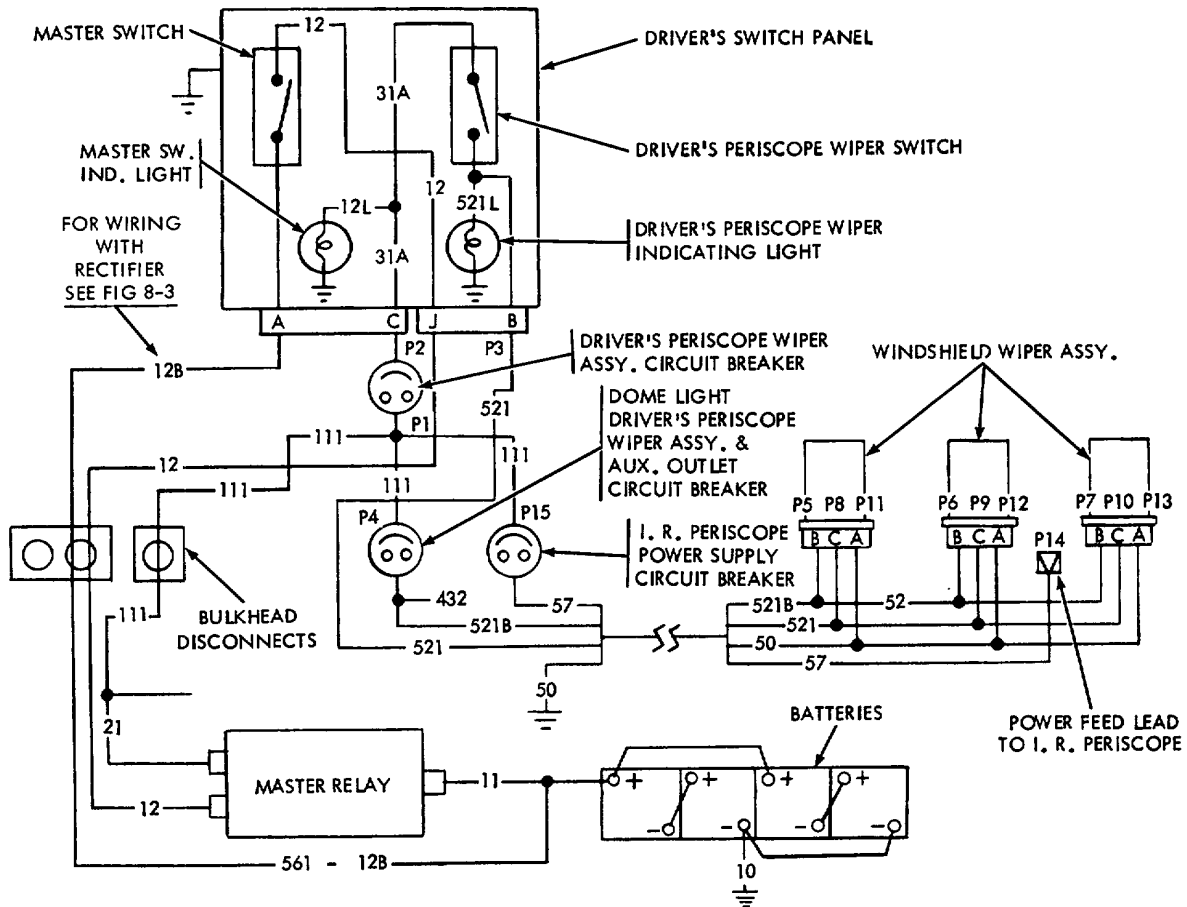

**(DESCRIPTION) DRIVER'S PERISCOPE WIPER ASSEMBLY**

THE DRIVER'S WIPER CIRCUIT CONSISTS OF 3 WIPER ASSEMBLIES, A WIPER SWITCH, INDICATOR LIGHT AND TWO CIRCUIT BREAKERS AND IS ENERGIZED AS FOLLOWS:

INCORPORATED IN THE HARNESS OF THE WIPER ASSEMBLY IS A CONNECTOR ON LEAD NO. 57 WHICH IS USED IN CONJUNCTION WITH THE XM 48 I R PERISCOPE ONLY. POWER FLOWS TO THE CONNECTOR AT ALL TIMES WHEN THE MASTER SWITCH IS ON.

1. WHEN THE MASTER RELAY IS ENERGIZED BY CLOSING THE MASTER SWITCH, POWER IS FED FROM THE MASTER RELAY THROUGH THE DRIVER'S PERISCOPE WIPER CIRCUIT BREAKER TO THE WIPER SWITCH.
2. WITH THE DRIVER'S PERISCOPE WIPER SWITCH ON POWER FLOWS TO THE INDICATOR LIGHT, POWER IS ALSO DIRECTED THROUGH LEAD 521 STARTING THE WIPER MOTORS.
3. POWER WILL FLOW THROUGH LEAD 521 B AT ALL TIMES AS LONG AS THE MASTER SWITCH IS CLOSED. A SWITCH WITHIN THE WIPER WILL SELECT POWER FROM EITHER LEAD 521 OR 521B CAUSING THE WIPER TO OPERATE. WHEN THE SWITCH IS TURNED OFF LEAD 521 WILL BE OPENED AND THE WIPERS WILL OPERATE FROM LEAD 521B. LEAD 521B WILL BE OPENED WITHIN THE MOTOR AND THE WIPERS WILL STOP IN THE NORMAL POSITION.

WE 66627

Figure 8-9. Troubleshooting - driver's periscope wiper circuits

TABLE 8-12. DRIVER'S PERISCOPE WIPER CIRCUITS (FIG. 8-9)

COMPONENT	CIRCUIT NUMBER	TEST POINTS		RESISTANCE (ohms)	CIRCUIT	REMARKS
		FROM	TO			
<b>CAUTION:</b> Disconnect battery positive and negative cables before making resistance or continuity tests.						
Windshield wiper switch feed panel	31A	P1	P2-C	0	Circuit through circuit breaker to	Infinity indicates open circuit or defective
Windshield wiper indicator light bulb	lead. 521L	P2-C	GND	170-210	Circuit through switch and light bulb	Infinity indicates switch open or defective lead. Close switch to get indicated resistance. Zero OHMS with switch closed indicates short circuit.
Windshield wiper switch	P2-C	P3-B		0 OR INF	Circuit through switch and panel	Infinity indicates switch "off". Zero OHMS indicates switch "on". Any in-between resistance indicates defective switch.
Windshield wiper lead	521	P3-B	P8-P9	0	Circuit from panel to wiper motor feed	Infinity indicates open circuit or defective lead.
Windshield wiper parking circuit lead	521B	P4	P5-P6 P7	0	Circuit from circuit breaker to wiper motor feed	Infinity indicates open circuit or defective lead.
Windshield wiper motor grounding circuit	50 P12 P13	P11-	GND	0	Circuit from wiper motor to ground	Infinity indicates open circuit or defective lead.
I R. periscope feed lead	57	P15	P14	0	Circuit through circuit breaker to LR. periscope connection.	Infinity indicates open circuit or defective lead.

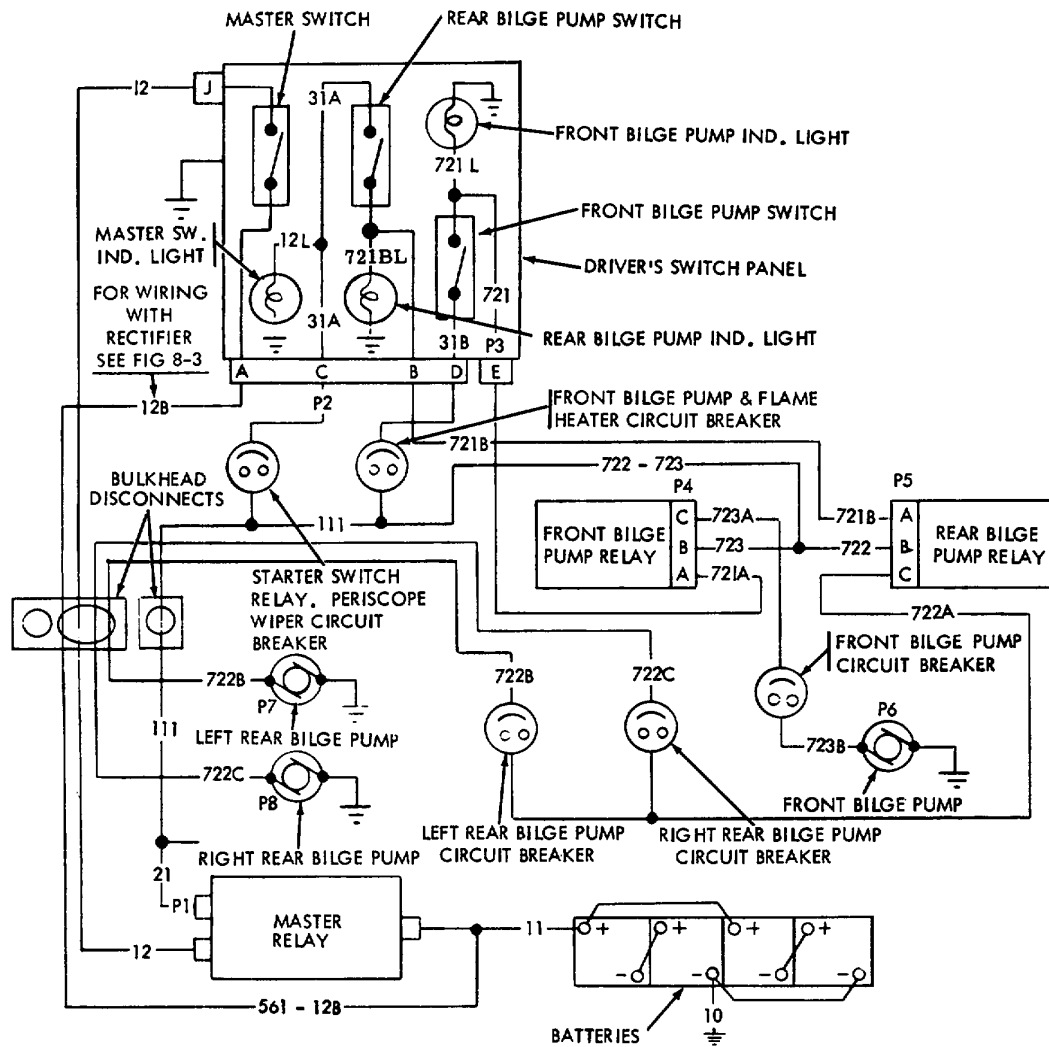

#### DESCRIPTION

THE BILGE PUMP CIRCUIT CONSISTS OF THREE BILGE PUMPS, TWO BILGE PUMP RELAYS, FIVE CIRCUIT BREAKERS, TWO SWITCHES, TWO BILGE PUMP INDICATING LIGHTS AND IS ENERGIZED AS FOLLOWS:

1. WHEN MASTER RELAY IS ENERGIZED BY TURNING MASTER SWITCH ON, CURRENT IS FED THROUGH STARTER SWITCH RELAY AND DRIVER'S PERISCOPE WIPER CIRCUIT BREAKER, FRONT BILGE PUMP AND FLAME HEATER CIRCUIT BREAKER, TO BOTH BILGE PUMP SWITCHES AND TO BOTH BILGE PUMP RELAYS.
2. WHEN THE FRONT BILGE PUMP SWITCH IS TURNED ON, CURRENT IS FED TO INDICATOR LIGHT AND THE FRONT PUMP RELAY ENERGIZING THE RELAY. CURRENT THEN FLOWS THROUGH RELAY CONTACTS THROUGH FRONT BILGE PUMP CIRCUIT BREAKER AND THROUGH BILGE PUMP TO GROUND.
3. WHEN REAR BILGE PUMP SWITCH IS TURNED ON, CURRENT IS FED TO INDICATOR LIGHT AND TO REAR PUMP RELAY ENERGIZING THE RELAY, CURRENT THEN FLOWS THROUGH RELAY CONTACTS THROUGH BOTH REAR BILGE PUMP CIRCUIT BREAKERS AND THROUGH BILGE PUMPS TO GROUND.

WE 66628

Figure 8-10. Troubleshooting-bilge pump circuits

TABLE 8-13. BILGE PUMP CIRCUITS (FIG. 8-10)

COMPONENT	CIRCUIT NUMBER	TEST POINTS		RESISTANCE (ohms)	CIRCUIT	REMARKS
		FROM	TO			
CAUTION: Disconnect battery positive and negative cables before making resistance or continuity tests.						
Main bilge system electrical feed	111	P1	P2-C	0	Circuit from master relay to the switch panel and both bilge pump relays	Infinity indicates open circuit or defective lead.
	111	P1	P2-D	0		
	723	P1	P4-B	0		
	722	P1	P5-B	0		
Front bilge pump switch	721	P2-D	P3-E	0 OR INF	Circuit through switch and panel	Front bilge pump switch "on": Infinity indicates open circuit, defective leads or switch. Front bilge pump switch "off": Zero OHMS indicates defective switch or short circuit.
Front bilge pump indicator light	721L	P2-D	GND	170-210	Circuit through switch panel and light bulb	Front bilge pump switch "on": Infinity indicates open circuit, defective leads or burned out light bulb. Zero OHMS indicates a short circuit.
Front bilge pump panel to relay lead Front bilge pump relay to pump lead Front bilge pump	721-721A lead.	P3-E	P4-A	0	Circuit from switch panel to relay	Infinity indicates open circuit or defective
	723A	P4-C	P6	0	Circuit from relay through circuit breaker to pump	Infinity indicates open circuit, defective lead or circuit breaker.
	723B	P6	GND	35-. 70	Circuit through pump	Resistance variation greater than .70 OHMS or less than .35 OHMS indicates defective pump.
Rear bilge pump switch	721B	P2-C	P2-B	0 OR INF	Circuit through switch and panel	Rear bilge pump switch "on": Infinity indicates open circuit, defective leads or switch. Rear bilge pump switch "off": Zero OHMS indicates defective switch or short circuit.
Rear bilge pump indicator light light bulb	721BL	P2-B	GND	170-210	Circuit through switch panel and	Rear bilge pump switch "off": Infinity indicates open circuit, defective leads or burned out bulb. Zero OHMS indicates a short circuit.
Rear bilge pump panel to relay lead	721B	P2-B	P5-A	0	Circuit from switch panel to relay	Infinity indicates open circuit or defective lead.

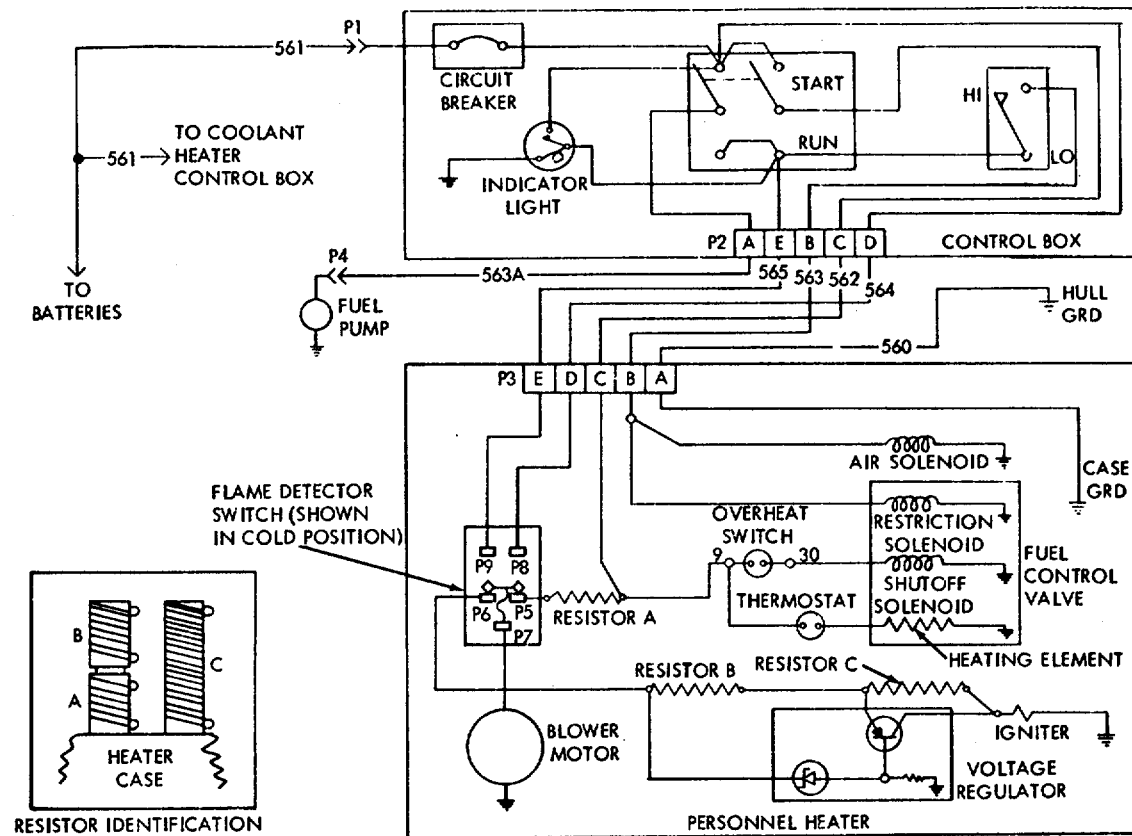

TABLE 8-13. BILGE PUMP CIRCUITS (FIG. 8-10) - CONTINUED

COMPONENT	CIRCUIT NUMBER	TEST POINTS		RESISTANCE (ohms)	CIRCUIT	REMARKS
		FROM	TO			
CAUTION: Disconnect battery positive and negative cables before making resistance or continuity tests.						
Rear bilge pump relay to left pump lead	722A 722B	P5-C	P7	0	Circuit from relay through circuit breaker to pump	Infinity indicates open circuit, defective lead or circuit breaker.
Rear bilge pump relay to right pump lead	722A 722C	P5-C	P8	0	Circuit from relay through circuit breaker to pump	Infinity indicates open circuit, defective lead or circuit breaker.
Left rear bilge pump	722B	P7	GND	.35-.70	Circuit through pump	Resistance variation greater than . 70 OHMS or less than . 35 OHMS indicates defective pump
Right rear bilge pump	722C	P8	GND	.35-. 70	Circuit through pump	Resistance variation greater than .70 OHMS or less than. 35 OHMS indicates defective pump.

TABLE 8-14. PERSONNEL HEATER CIRCUITS (FIG. 8-11)

COMPONENT	CIRCUIT NUMBER	TEST POINTS		RESISTANCE (ohms)	CIRCUIT	REMARKS
		FROM	TO			
Disconnect power lead at P1, and use voltmeter to check voltage from battery at 1. Leave connector P1 disconnected during all ohmeter tests.						
<b>WIRING</b>						
Power supply	561	P1	P2D	0	Through lead and circuit breaker	
Harness	563	P2B	P3B	0	Through lead	Resistance indicates defective circuit.
	562	P2C	P3C	0	Through lead	
	565	P2E	P3E	0	Through lead	
	564	P2D	P3D	0	Through lead	
	560	P3A	GRD	0	External grd. circuit	
563A pump	P2A	P4	0	Through lead to fuel		
---	P3A	Case	0	Internal grd. circuit		
<b>CONTROLS</b>						
Start-Off-Run Switch (OFF)	P2D	P2A	INF			Any other reading indicates defective switch
Start-Off-Run Switch (START)	P2D	P2C	INF			
Start -Off -Run Switch (RUN)	P2D	P2A	0			
Start -Off -Run Switch (RUN)	P2D	P2C	0			
(Leave Start-Off-Run Switch in RUN):						
Hi-Lo Switch(L(O indicates defective switch		P2B	P2E	INF		Any other reading
Hi-Lo Switch (HI)		P2B	P2E	0		



#### DESCRIPTION

THE PERSONNEL HEATER CIRCUIT CONSISTS OF A "START-OFF-RUN" SWITCH, INDICATOR LIGHT, 15 AMP CIRCUIT BREAKER, AND "HI-LO" SWITCH (ALL LOCATED IN THE CONTROL BOX), FUEL PUMP, AND THE HEATER. THE PERSONNEL HEATER HAS STARTING, RUNNING, AND PURGING CIRCUITS, ENERGIZED AS FOLLOWS:

- A. POWER IS FED FROM THE VEHICLE BATTERIES THROUGH THE CIRCUIT BREAKER TO THE START-OFF-RUN SWITCH.
- B. WHEN START-OFF-RUN SWITCH IS HELD IN "START" POSITION POWER IS FED:
  1. TO FUEL PUMP TO GROUND COMPLETING CIRCUIT.
  2. THROUGH OVERHEAT SWITCH TO FUEL SHUTOFF SOLENOID TO GROUND COMPLETING CIRCUIT.
  3. THROUGH THERMOSTAT TO FUEL VALVE HEATING ELEMENT TO GROUND COMPLETING CIRCUIT.
  4. THROUGH FLAME DETECTOR SWITCH THROUGH VOLTAGE REGULATOR TO IGNITER TO GROUND COMPLETING CIRCUIT.
  5. THROUGH RESISTOR THROUGH FLAME DETECTOR SWITCH TO BLOWER MOTOR TO GROUND COMPLETING CIRCUIT.
- C. WHEN FLAME DETECTOR ACTUATES, POWER TO IGNITER IS CUT OFF AND POWER IS FED:
  1. THROUGH FLAME DETECTOR SWITCH TO INDICATOR LIGHT TO GROUND COMPLETING CIRCUIT.
  2. THROUGH FLAME DETECTOR SWITCH THROUGH RESISTOR TO BLOWER MOTOR TO GROUND COMPLETING CIRCUIT.
  3. TO HI-LO SELECTOR SWITCH. WHEN SELECTOR SWITCH IS PLACED IN "HI" POSITION POWER IS FED THROUGH COOLANT THERMOSTAT THROUGH RESTRICTION THERMOSTAT TO RESTRICTION SOLENOID, AND TO BLOWER MOTOR, TO GROUND COMPLETING CIRCUITS.
- D. WHEN FLAME DETECTOR SWITCH HAS ACTUATED, SWITCHING START-OFF-RUN SWITCH TO "RUN" MAINTAINS POWER TO FUEL PUMP, FUEL VALVE(S), BLOWER MOTOR, AND HI-LO SELECTOR SWITCH.
- E. WHEN START-OFF-RUN SWITCH IS PLACED IN "OFF" POSITION, POWER IS FED THROUGH FLAME DETECTOR SWITCH TO BLOWER MOTOR TO GROUND COMPLETING CIRCUIT.
- F. WHEN HEATER COOLS, FLAME DETECTOR ACTUATES CUTTING OFF POWER TO BLOWER MOTOR.

WE 10983A

Figure 8-11. (Superseded) Troubleshooting - personnel heater circuits

TABLE 8-14. PERSONNEL HEATER CIRCUITS (FIGURE 8-11) - CONTINUED

COMPONENT	CIRCUIT NUMBER	TEST POINTS		RESISTANCE (ohms)	CIRCUIT	REMARKS
		FROM	TO			
<u>HEATER</u>						
Igniter		Igniter term	Grd Strap	Approx. 0. 5	Through igniter	Zero or high reading indicates defective igniter. Any other reading indicates switch out of adjust. ment or defective. INF indicates defective switch
Flame Detector Switch (Cold position only)		P5	P6	O	Through switch	
Overheat Switch		P8	P9	INF	Through switch	
		Term. 9	Term 30	O	Through switch	INF indicates defective switch
Resistor "A" (Blower Resistor:		Across resistor terminals		Approx. 0.4	Through resistor	INF indicates open resistor
Resistor "B" (Igniter Resistor)		Across resistor terminals		Approx. 0. 6	Through resistor	INF indicates open resistor
Resistor "C" (Igniter Resistor)		Across resistor terminals		Approx. 1.0	Through resistor	INF indicates open resistor
Shutoff Solenoid		Lead#30	Case Disconnected from overheat switch	Approx. 140	Through solenoid to grd	High or low reading indicates defective solenoid
Restriction Solenoid and Air Valve Solenoid		P3B	Case	Approx. 70	Through solenoids in parallel to grd	High or low reading indicates one or the other solenoid is defective

TABLE 8-14.1. WINTERIZATION KIT COOLANT HEATER CIRCUITS (FIGURE 8-11.1)

COMPONENT	CIRCUIT NUMBER	TEST POINTS		RESISTANCE (ohms)	CIRCUIT	REMARKS
		FROM	TO			
Disconnect power lead at P1, and use voltmeter to check power supply from battery at P1. Leave connector P1 disconnected during all ohmeter tests.						
<u>WIRING</u>						
Power Supply	561	P1	P2D	O	Through lead and circuit breaker	Resistance indicates defective circuit
Harness	564	P2D	P3D	O	Through lead	
	565	P2E	P3E	O	Through Lead	
	565	P3E	P10	O	Through lead to coolant pump	
	562	P2C	P3C	O	Through lead	
	563	P2B	P3B	O	Through lead	
	563A	P2A	P4	0	Through lead to fuel pump	

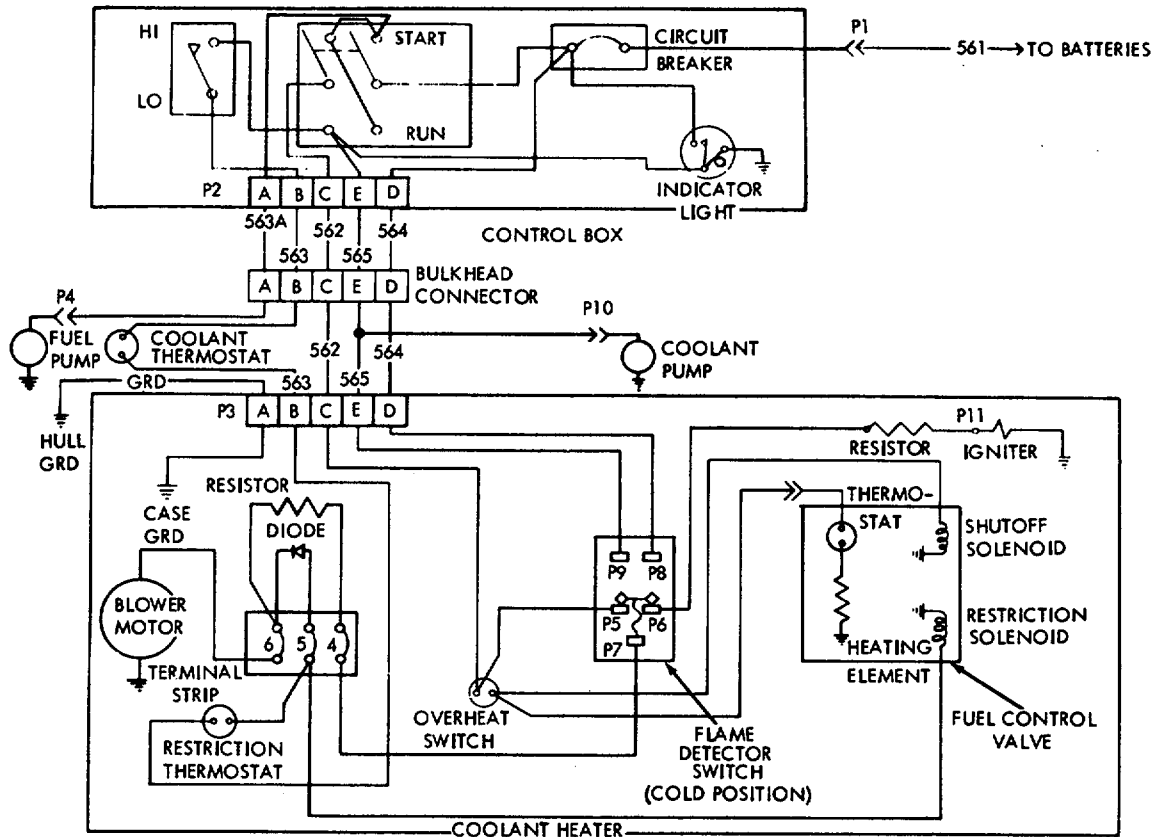
**DESCRIPTION**

THE WINTERIZATION COOLANT HEATER CIRCUIT CONSISTS OF A "START-OFF-RUN" SWITCH, INDICATOR LIGHT, 15 AMP CIRCUIT BREAKER, AND "HI-LO" SWITCH (ALL LOCATED IN THE CONTROL BOX), FUEL PUMP, COOLANT CIRCULATING PUMP, COOLANT THERMOSTAT, AND THE COOLANT HEATER. THE COOLANT HEATER HAS STARTING, RUNNING, AND PURGING CIRCUITS, ENERGIZED AS FOLLOWS:

- A. POWER IS FED FROM THE VEHICLE BATTERIES THROUGH THE CIRCUIT BREAKER TO THE START-OFF-RUN SWITCH.
- B. WHEN START-OFF-RUN SWITCH IS HELD IN "START" POSITION POWER IS FED:
  1. TO FUEL PUMP TO GROUND COMPLETING CIRCUIT.
  2. THROUGH OVERHEAT SWITCH TO FUEL SHUTOFF SOLENOID TO GROUND COMPLETING CIRCUIT.
  3. THROUGH THERMOSTAT TO FUEL VALVE HEATING ELEMENT TO GROUND COMPLETING CIRCUIT.
  4. THROUGH FLAME DETECTOR SWITCH THROUGH RESISTOR TO IGNITER TO GROUND COMPLETING CIRCUIT.
  5. THROUGH FLAME DETECTOR SWITCH THROUGH RESISTOR TO BLOWER MOTOR TO GROUND COMPLETING CIRCUIT.
- C. WHEN FLAME DETECTOR ACTUATES, POWER TO IGNITER IS CUT OFF AND POWER IS FED:
  1. THROUGH FLAME DETECTOR SWITCH TO INDICATOR LIGHT TO GROUND COMPLETING CIRCUIT.
  2. THROUGH FLAME DETECTOR SWITCH THROUGH RESISTOR TO BLOWER MOTOR TO GROUND COMPLETING CIRCUIT.
  3. THROUGH FLAME DETECTOR SWITCH TO COOLANT CIRCULATING PUMP TO GROUND COMPLETING CIRCUIT.
- D. WHEN FLAME DETECTOR SWITCH HAS ACTUATED, SWITCHING START-OFF-RUN SWITCH TO "RUN" MAINTAINS POWER TO FUEL PUMP, FUEL VALVE(S), BLOWER MOTOR AND COOLANT CIRCULATING PUMP, AND FEEDS POWER TO HI-LO SELECTOR SWITCH.
- E. WHEN SELECTOR SWITCH IS PLACED IN "HI" POSITION POWER IS FED THROUGH COOLANT THERMOSTAT THROUGH RESTRICTION THERMOSTAT TO RESTRICTION SOLENOID, AND THROUGH DIODE TO BLOWER MOTOR, TO GROUND COMPLETING CIRCUITS.
- F. WHEN START-OFF-RUN SWITCH IS PLACED IN "OFF" POSITION, POWER IS FED THROUGH FLAME DETECTOR SWITCH TO BLOWER MOTOR AND COOLANT CIRCULATING PUMP TO GROUND COMPLETING CIRCUITS.
- G. WHEN HEATER COOLS, FLAME DETECTOR ACTUATES CUTTING OFF POWER TO BLOWER MOTOR AND CIRCULATING PUMP.

WE 11956

Figure 8-11.1. (Added) Troubleshooting - winterization kit coolant heater circuits

TABLE 8-14.1 WINTERIZATION KIT COOLANT HEATER CIRCUITS (FIG. 8-11.1) - CONTINUED

COMPONENT	CIRCUIT NUMBER	TEST POINTS		RESISTANCE (ohms)	CIRCUIT	REMARKS
		FROM	TO			
Harness (Cont'd)		P3A	Grd.	0	External grd. circuit	
		P3A	Case	0	Internal grd. circuit	
<b>CONTROLS</b>						
Start-Off-Run Switch (OFF)		P2D	P2A	INF	Through switch	Any other reading indicates defective switch.
		P2D	P2C	INF		
		P2D	P2E	INF		
Start-Off-Run Switch (START)		P2D	P2A	0	Through switch	
		P2D	P2C	0		
Start-Off-Run Switch (RUN)		P2D	P2A	0	Through switch	
		P2D	P2C	INF		
(Leave Start-Off-Run Switch in RUN):						
Hi-Lo Switch (HI)		P2D	P2B	0	Through switch	Any other reading indicates defective switch.
HI-Lo Switch (LO)		P2D	P2B	INF	Through switch	
Coolant Thermostat (Coolant temp. below 120°F.)		Across thermostat contacts		0	Through thermostat	
Coolant thermostat (Coolant temp. above 160°F.)		Across thermostat contacts		INF	Through thermostat	Any other reading indicates defective thermostat.
<b>HEATER</b>						
Igniter		P11	Case	Approx. 0.5	Through igniter	Zero or high reading indicates defective igniter. INF indicates open resistor.
Igniter Resistor		Across Resistor		Approx. 1.6	Through resistor	
Flame Detector Switch (cold only)		P5	P6	0	Through switch	Any other reading indicates switch out of adjustment or defective.
		P5	P7	0		
		P8	P9	INF		
Restriction Thermostat (coolant temp. below 120°F)		P3B	TS5	0	Through thermostat	Any other reading indicates defective thermostat.
Restriction Thermostat (coolant temp. above 190°F)		P3B	TS5	INF	Through thermostat	
Diode		TS5	TS6	Low and high by reversing probes	Through diode	Same reading both ways indicates defective diode.

COMPONENT	CIRCUIT NUMBER	TEST POINTS		RESISTANCE (ohms)	CIRCUIT	REMARKS
		FROM	TO			
<b>HEATER</b> Continued						
Shutoff Solenoid		Lead #51 Disconnected	Case	Approx. 140	Through solenoid	Other reading indicates defective solenoid
Restriction Solenoid		Lead from TS5 Disconnected	Case	Approx. 140	Through solenoid	
Blower Resistor		Through Resistor leads disconnected at TS4 and TS6		Approx. 25	Through resistor	INF indicates open resistor
Fuel Valve Heating Element		Lead disconnected from valve thermostat	Case	Approx. 10	Through heating element	INF indicates burned out heating element.
Fuel Valve Thermostat (temp. below 50°F)		Across thermostat (leads disconnected)		0	Through thermostat	Other reading indicates defective thermostat.
Fuel Valve Thermostat (temp. above 70°F)		Across thermostat (leads disconnected)		INF	Through thermostat	

8-66.3  
(8-66.4 Blank)

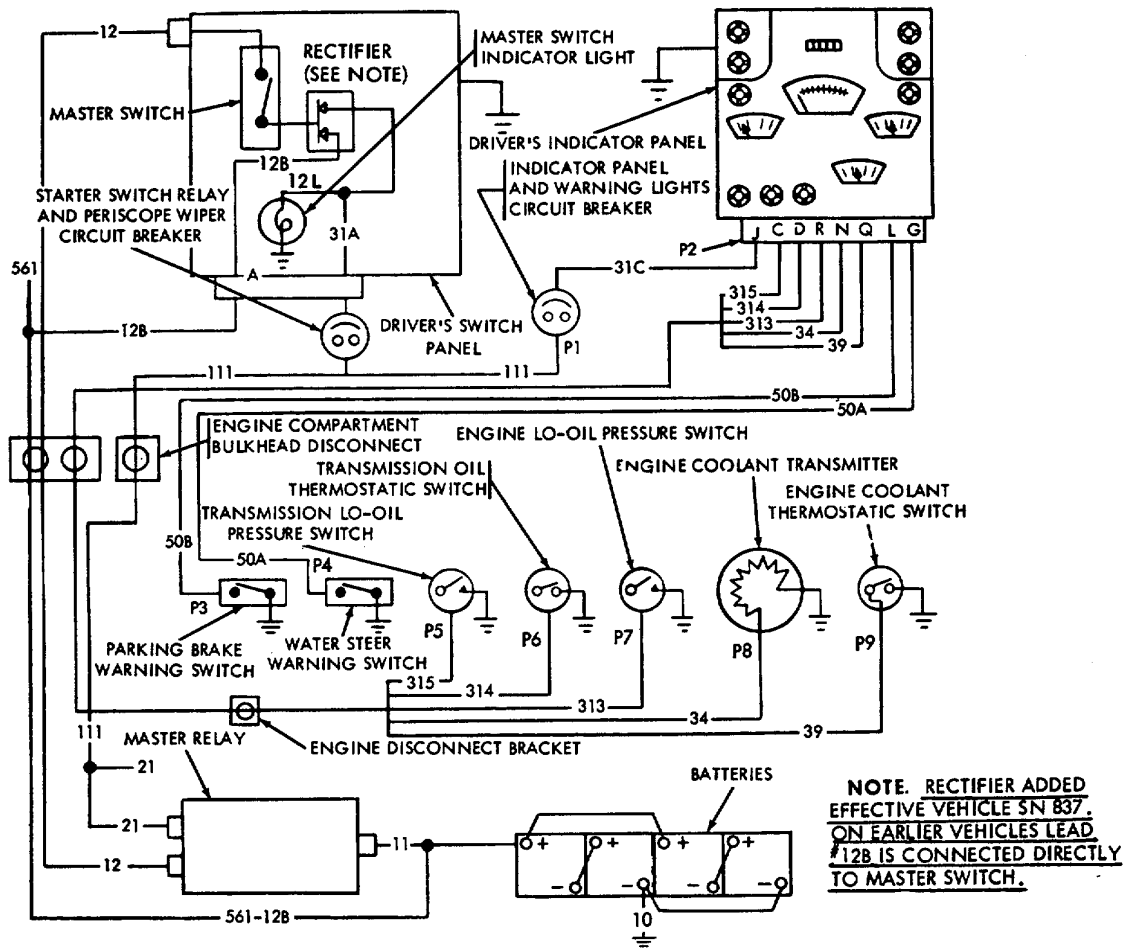

#### DESCRIPTION

THE WARNING LIGHT CIRCUITS CONSIST OF A 15 AMP CIRCUIT BREAKER, ENGINE COOLANT TRANSMITTER, ENGINE COOLANT THERMOSTATIC SWITCH, ENGINE OIL LOW PRESSURE SWITCH, TRANSMISSION OIL THERMOSTATIC SWITCH, TRANSMISSION OIL LOW PRESSURE SWITCH, PARKING BRAKE WARNING SWITCH, AND WATER STEER WARNING SWITCH. THE WARNING LIGHT CIRCUITS ARE ENERGIZED AS FOLLOWS:

- (1) WHEN THE MASTER RELAY IS ENERGIZED BY CLOSING THE MASTER SWITCH, CURRENT FLOWS FROM THE MASTER RELAY THROUGH THE CIRCUIT BREAKER AND TO THE DRIVER'S INDICATOR PANEL, THROUGH THE WARNING LIGHTS IN THE PANEL AND TO THE RESPECTIVE SWITCHES.
- (2) WHEN THE PARKING BRAKE LOCK IS ACTUATED, THE PARKING BRAKE WARNING SWITCH CLOSING COMPLETING THE CIRCUIT TO GROUND AND THE PARKING BRAKE WARNING LIGHT LIGHTS.
- (3) WHEN THE WATER STEER SELECTOR KNOB IS MOVED SLIGHTLY TOWARD THE WATER POSITION, THE WATER STEER WARNING SWITCH CLOSING COMPLETING THE CIRCUIT TO GROUND AND THE WATER STEER WARNING LIGHT LIGHTS.
- (4) THE ENGINE AND TRANSMISSION LO-OIL PRESSURE WARNING LIGHTS ARE LIT AS THEIR RESPECTIVE SWITCHES ARE CLOSED. WHEN THE ENGINE IS STARTED, BOTH OF THE LIGHTS WILL GO OUT WHEN THE OIL PRESSURES EXCEED MINIMUM.
- (5) THE ENGINE LO-OIL PRESSURE WARNING SWITCH WILL CLOSE, AND THE LIGHT WILL LIGHT, WHENEVER THE OIL PRESSURE DROPS BELOW 9-13 PSI.
- (6) THE TRANSMISSION LO-OIL PRESSURE WARNING SWITCH WILL CLOSE, AND THE LIGHT WILL LIGHT, WHENEVER THE OIL PRESSURE DROPS BELOW 4-8 PSI.
- (7) THE ENGINE COOLANT TEMPERATURE WARNING SWITCH WILL CLOSE AND THE ENGINE HIGH COOLANT TEMPERATURE WARNING LIGHT WILL LIGHT, WHENEVER THE COOLANT TEMPERATURE EXCEEDS 232° F.
- (8) THE TRANSMISSION HIGH OIL TEMPERATURE WARNING SWITCH WILL CLOSE, AND THE TRANSMISSION HIGH OIL TEMPERATURE WARNING LIGHT WILL LIGHT, WHENEVER THE OIL TEMPERATURE EXCEEDS TEMPERATURE SWITCH SETTING.
- (9) THE ENGINE COOLANT INDICATOR PROVIDES A DIRECT TEMPERATURE READING WHICH VARIES WITH RESISTANCE CHANGES IN THE TRANSMITTER ON THE ENGINE.

WE 66629

Figure 8-12. Troubleshooting-power plant indicator and warning light circuits

TABLE 8-15. POWER PLANT INDICATOR AND WARNING LIGHT CIRCUITS (FIG 8-12)

COMPONENT	CIRCUIT NUMBER	TEST POINTS		RESISTANCE (ohms)	CIRCUIT	REMARKS
		FROM	TO			
<b>CAUTION:</b> Disconnect battery positive and negative cables before making resistance or continuity tests.						
Instrument power lead	31C	P1	P2-J	0	Through circuit breaker to panel input	Infinity indicates open circuit or defective lead.
Transmission lo-oil pressure warning light		P2-J	P2-C	170-210	Through light and panel	Infinity indicates open circuit, defective lead or burned out bulb. Zero OHMS indicates short circuit.
Transmission lo-oil pressure lead	315	P2-C	P5	0	From panel to switch	Infinity indicates open circuit or defective lead.
Transmission lo-oil pressure switch		P5	CASE	0	Through switch	Infinity indicates open circuit and defective switch.
Transmission high temperature warning light		P2-J	P2-D	170-210	Through light and panel	Infinity indicates open circuit, defective lead or burned out bulb. Zero OHMS indicates short circuit.
Transmission high temperature lead	314	P2-D	P6	0	From panel to switch	Infinity indicates open circuit or defective lead.
Transmission high temperature warning light switch		P6	CASE	INF	Through switch	Resistance indicates a defective switch.
Engine lo-oil pressure warning light		P2-J	P2-R	170-210	Through light and panel	Infinity indicates open circuit, defective lead, or burned out bulb. Zero OHMS indicates a short circuit.
Engine lo-oil pressure lead	313	P2-R	P7	0	From panel to switch	Infinity indicates open circuit or defective lead.
Engine lo-oil pressure switch		P7	CASE	0	Through switch	Infinity indicates open circuit and defective switch.
Engine coolant temperature indicator		P2-J P2-J	P2-N CASE	290 200	Through indicator By-pass circuit through indicator	Infinity indicates open circuit, defective lead, or defective indicator. Zero OHMS indicates short circuit for defective indicator.
Engine coolant temperature lead	34	P2-N	P8	0	From panel to transmitter	Infinity indicates open circuit or defective lead.
Engine coolant temperature transmitter		P8	CASE	6400-6700 @72°F	Through transmitter	Infinity or zero OHMS indicates defective transmitter.



TABLE 8-15. POWER PLANT INDICATOR AND WARNING LIGHT CIRCUITS (FIG 8-12) - CONTINUED

COMPONENT	CIRCUIT NUMBER	TEST POINTS		RESISTANCE (ohms)	CIRCUIT	REMARKS
		FROM	TO			
<b>CAUTION:</b> Disconnect battery positive and negative cables before making resistance or continuity tests.						
Engine high temperature warning light	39	P2-J	P2-Q	170-210	Through light and panel	Infinity indicates open circuit, defective lead or burned out bulb. Zero OHMS indicates a short circuit.
Engine high temperature warning light lead		P2-Q	P9	0	From panel to switch	Infinity indicates open circuit or defective lead.
Engine high temperature warning light switch		P9	CASE	INF	Through switch	Resistance indicates a defective switch.
Parking brake warning light	50B	P2-J	P2-L	170-210	Through light and panel	Infinity indicates open circuit, defective lead, or burned out bulb. Zero OHMS indicates a short circuit.
Parking brake warning light lead		P2-L	P3	0	From panel to switch	Infinity indicates open circuit or defective lead.
Parking brake warning light switch		P3	GND	0 OR INF	Through switch	Zero with parking brake on. Infinity with parking brake off. Adjust if required.
Water steer warning light	50A	P2-J	P2-G	170-210	Through light and panel	Infinity indicates open circuit, defective lead, or burned out bulb. Zero OHMS indicates a short circuit.
Water steer warning light lead		P2-G	P4	0	From panel to switch	Infinity indicates open circuit or defective lead.
Water steer warning light switch		P4	GND	0 OR INF	Through switch	Zero in water position. Infinity in land position. Adjust if required.

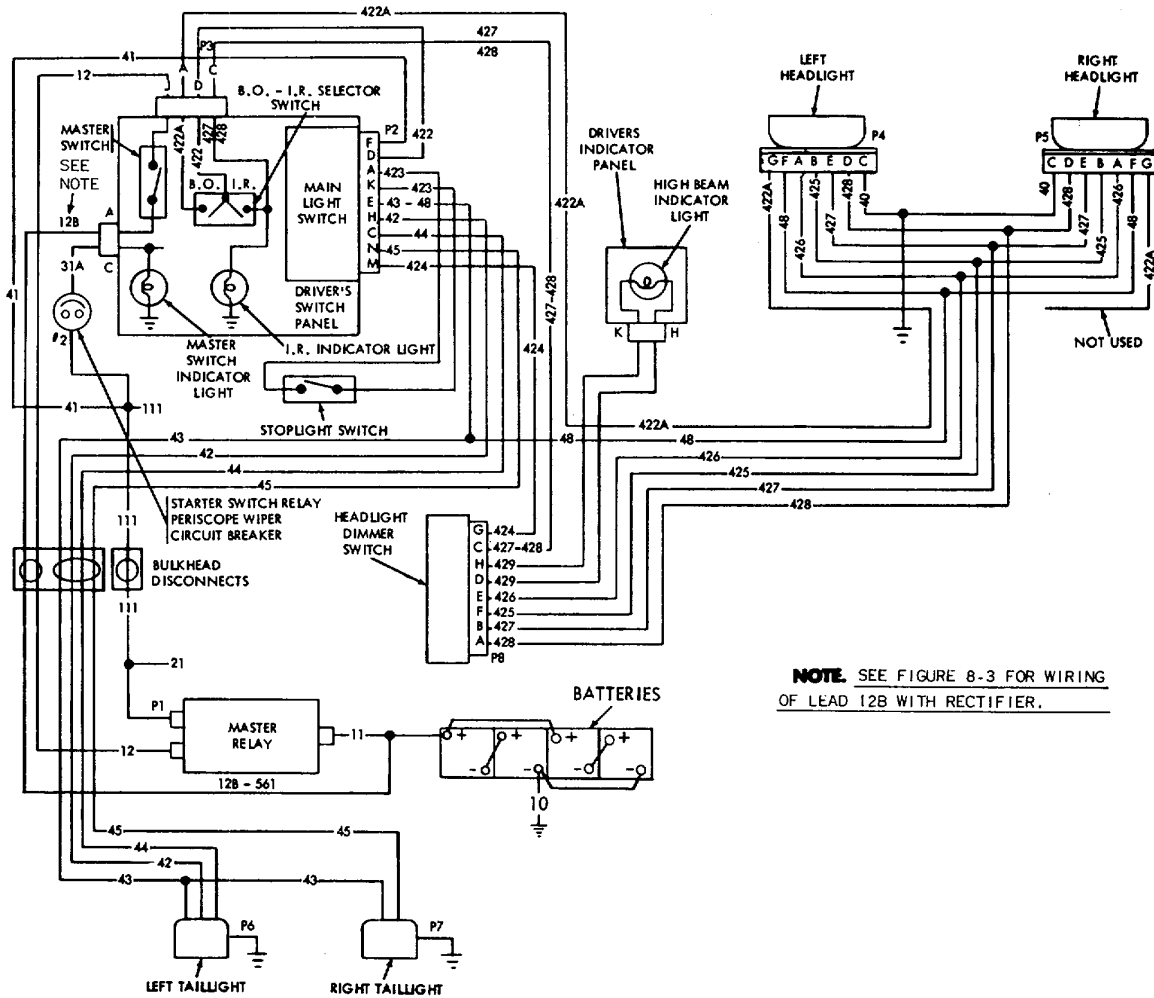

**DESCRIPTION**

1. THE SERVICE HEADLIGHT CIRCUIT CONSISTS OF TWO SERVICE HEADLIGHTS, DIMMER SWITCH, HIGH BEAM INDICATOR LIGHT AND MAIN LIGHT SWITCH WHICH INCORPORATES A BUILT IN CIRCUIT BREAKER.
2. THE SERVICE TAILLIGHT CIRCUIT CONSISTS OF MAIN LIGHT SWITCH AND LEFT TAILLAMP.
3. THE SERVICE STOPLIGHT CIRCUIT CONSISTS OF A CIRCUIT IN LEFT TAILLAMP, STOPLIGHT SWITCH, AND MAIN LIGHT SWITCH.
4. THE BLACKOUT MARKER CIRCUIT CONSISTS OF A MARKER LIGHT IN LEFT AND RIGHT HEADLIGHT AND TAILLAMP ASSEMBLIES, CIRCUITS IN MAIN LIGHT SWITCH IR-BO SELECTOR SWITCH. THE BLACKOUT MARKER LIGHT CIRCUIT HAS ITS OWN SWITCH POSITION, HOWEVER THEY ARE ALSO ILLUMINATED WHEN BO DRIVE LIGHTS OR IR HEADLIGHTS ARE OPERATED.
5. THE BLACKOUT DRIVE LIGHT CIRCUIT CONSISTS OF A BLACKOUT DRIVE UNIT IN LEFT HEADLIGHT ASSEMBLY, A BO-IR SELECTOR SWITCH, AND MAIN LIGHT SWITCH.
6. THE SERVICE BLACKOUT HEADLIGHT CIRCUIT CONSISTS OF TWO SERVICE HEADLIGHTS, DIMMER SWITCH, HIGH BEAM INDICATOR LIGHT, BO-IR SELECTOR SWITCH AND MAIN LIGHT SWITCH.
7. THE BLACKOUT STOPLIGHT CIRCUIT CONSISTS OF A BLACKOUT STOPLIGHT IN RIGHT TAILLAMP ASSEMBLY, STOPLIGHT SWITCH AND MAIN LIGHT SWITCH.

WE 66630

Figure 8-13. Troubleshooting-vehicle driving light circuits

TABLE 8-16. VEHICLE DRIVING LIGHT CIRCUITS

**THE CIRCUITS ARE ENERGIZED AS FOLLOWS: (CONTINUED FROM FIGURE 8-13)**

1. When master switch is energized, power is fed from the master relay to main light switch.
2. When main light switch is placed in "service drive" position, power is fed through dimmer switch, low beam position, through service headlight low beam to ground, completing circuit. When dimmer switch is placed in high beam position, power is fed through service headlight high beam to ground and high beam indicator light through service blackout headlight high beam filament to ground, completing circuit. Power is also fed from main light switch through service taillight (in left tail lamp) to ground, completing circuit. Power is also fed from main light switch to stoplight switch through main light switch and service stoplight (in left tail lamp) to ground, completing circuit.
3. When main light switch is placed in "stoplight" position, power is fed from main light switch to stoplight switch, which when closed, feeds power through main light switch and service stoplight (in left tail lamp) to ground, completing circuit.
4. When main light switch is placed in "BO MARKER" position, power is fed through both front and rear blackout marker lights to ground, completing circuit.
5. When main light switch is placed in "BO DRIVE" position, power is fed to all blackout marker lights to ground, completing circuit. Power is also fed to the BO/IR selector switch. When the BO/IR selector switch is placed in "BO" position, power is fed through blackout drive light (in left headlight) to ground, completing circuit. When the "BO/IR" selector switch is placed in "IR" position, power is fed through the dimmer switch, low beam position, through service blackout headlight low beam to ground, completing circuit. When dimmer switch is placed in "HIGH BEAM" position, power is fed through service blackout headlight high beam to ground and high beam indicator light through service headlight high beam filament to ground completing circuit. Power is fed from main light switch to stoplight switch, when stoplight switch is closed, power is fed from stoplight switch through main light switch to blackout stoplight (in right tail lamp) to ground, completing circuit.

TABLE 8-16. VEHICLE DRIVING LIGHT CIRCUITS - CONTINUED

COMPONENT	CIRCUIT NUMBER	TEST POINTS		RESISTANCE (ohms)	CIRCUIT	REMARKS
		FROM	TO			
CAUTION: Disconnect battery positive and negative cables before making resistance or continuity tests.						
Main light switch feed	111 41	P1	P2-F	0	Main light switch feed	Infinity indicates open circuit or defective lead.
Main light switch, circuit breaker, and service drive section		P2-F	P2-A H M	0	Through switch, circuit breaker, and service headlight section	Switch lever in "Ser Drive", infinity or resistance indicates defective switch.
Main light switch service stop section		P2-F	P2-A	0	Through switch, circuit breaker and service stoplight section	Switch lever in "Stoplight", infinity or resistance indicates defective switch.
Main light switch B.O. marker section		P2-F	P2-A E	0	Through switch, circuit breaker and B.O. marker section	Switch lever in "B.O. Marker", infinity or resistance indicates defective switch.
Main light switch B.O. drive section		P2-F	P2-A D E	0	Through switch, circuit breaker and B.O. drive section	Switch lever in "B.O. Drive", infinity or resistance indicates defective switch.
B.O./L.R. selector switch feed lead	422	P2-D	P3-D	0	In harness between main light switch and switch panel	Infinity indicates open circuit or defective lead.
B.O./L.R. selector switch - B.O. side		P3-D	P3-A	0	Through switch and switch panel	Selector switch in "B.O." position infinity or resistance indicates defective switch.
B.O./L.R. selector switch - L.R. side		P3-D	P3-C	0	Through switch and switch panel	Selector switch in "L.R." position. Infinity or resistance indicates defective switch.
L.R. indicator light	427L 428L	P3-C	GND	170-210	Through switch panel and light bulb	Selector switch in "B.O." position. Infinity indicates open circuit or burned out bulb. Zero OHMS indicates short circuit.
Stoplight switch	423	P2-A	P2-K	0 OR INF	In harness from main switch to brake switch and return	Foot brake at rest: Zero OHMS indicates defective switch, switch out of adjustment, or defective leads.  Foot brake depressed: Infinity indicates open circuit, defective leads, defective switch, or switch out of adjustment.
B.O. drivelight lead	422A	P3-A	P4-G	0	From switch panel to left headlight base connection	Infinity indicates open circuit or defective lead.

TABLE 8-16. VEHICLE DRIVING LIGHT CIRCUITS (FIG. 8-13) - CONTINUED

COMPONENT	CIRCUIT NUMBER	TEST POINTS		RESISTANCE (ohms)	CIRCUIT	REMARKS
		FROM	TO			
<b>CAUTION:</b> Disconnect battery positive and negative cables before making resistance or continuity tests.						
LR headlights lead	427-428	P3-C	P8-C	0	From switch panel, through harness, to dimmer switch	Infinity indicates open circuit or defective lead.
Service headlights lead	424	P2-M	P8-G	0	From switch panel, through harness, to dimmer switch	Infinity indicates open circuit or defective lead.
B.O. marker light lead to left taillight	43	P2-E	P6 (43 or 24)	0	From main light switch, through harness, to taillight marker light socket	Infinity indicates open circuit or defective lead.
B. OO. marker light lead to right taillight	43	P2-E	P7 (43 or 24)	0	From main light switch, through harness, to taillight marker light socket	Infinity indicates open circuit or defective lead.
B. OO. marker light lead to left headlight	48	P2-E	P4-F	0	From main light switch, through harness, to headlight base connection	Infinity indicates open circuit or defective lead.
B.O. marker light lead to right headlight	48	P2-E	P5-F	0	From main light switch, through harness, to headlight base connection	Infinity indicates open circuit or defective lead.
Left (service) taillight lead for service taillight	42 or 21)	P2-H	P6 (42	0	From main light switch, through harness, to service taillight socket	Infinity indicates open circuit or defective lead.
Left (service) taillight lead for service stoplight	44 or 22)	P2-C	P6 (44	0	From main light switch, through harness, to service stoplight socket	Infinity indicates open circuit or defective lead.
Right (B.O.)taillight lead for B. O. stoplight	45 or 23)	P2-N	P7 (45	r	From main light switch, through harness, to B.O taillight socket	Infinity indicates open circuit or defective lead.
High beam indicator light and leads from dimmer switch	429	P8-H		170-210	From dimmer switch through harness, indicator light, and indicator	Infinity indicates open circuit, defective leads or burned out bulb. Zero OHMS indicates
Service headlight leads from dimmer switch for lo beam	426	P8-E	P4-A P5-A	0	From dimmer switch, through harness, to	Infinity indicates open circuit or defective
Service headlight leads from dimmer switch for hi beam	425 P5-B	P8-F	P4-B	0	From dimmer switch, through harness, to headlight base	Infinity indicates open circuit or defective leads.

TABLE 8-16. VEHICLE DRIVING LIGHT CIRCUITS (FIG. 8-13) - CONTINUED

COMPONENT	CIRCUIT NUMBER	TEST POINTS		RESISTANCE (ohms)	CIRCUIT	REMARKS
		FROM	TO			
CAUTION: Disconnect battery positive and negative cables before making resistance or continuity tests.						
I.R. headlight leads from dimmer switch for hi beam	427	P8-B	P4-E	0	From dimmer switch, through harness, to headlight base	Infinity indicates open circuit or defective leads.
I.R. headlight leads from dimmer switch for lo beam	428	P8-A	P4-D	0	From dimmer switch, through harness, to headlight base	Infinity indicates open circuit or defective leads.
Headlight ground leads	40	P4-C P5-C	GND	0	From headlight bases to ground	Infinity indicates open circuit or defective leads.
Headlight internal circuits - both assemblies are identical						
Headlight ground		P4-C	Housing	0	Ground circuit through internal wiring	Infinity indicates open circuit or defective leads.
I.R. headlight lo beam		P5-C P4-D P5-D	Housing P4-C P5-C	1.	Through headlight and bulb filament to ground	Infinity indicates open circuit, defective lead or burned out filament. Zero OHMS indicates short circuit.
L R. headlight hi beam		P4-E P5-E	P4-C P5-C	.5	Through headlight and bulb filament to ground	Infinity indicates open circuit, defective lead or burned out filament. Zero OHMS indicates short circuit.
Service headlight hi beam		P4-B P5-B	P4-C P5-C	.5	Through headlight and bulb filament to ground	Infinity indicates open circuit, defective lead or burned out filament, Zero OHMS indicates short circuit.
Service headlight lo beam		P4-A P5-A	P4-C P5-C	1.	Through headlight and bulb filament to ground	Infinity indicates open circuit, defective lead or burned out filament. Zero OHMS indicates short circuit.
B. 00. marker light		P4-F P5-F	P4-C P5-C	30	Through headlight and bulb filament to ground	Infinity indicates open circuit, defective lead or burned out filament. Zero OHMS indicates short circuit.
B. 0. drive light		P4-G	P4-C	2.6	Through headlight and bulb filament to ground	Infinity indicates open circuit defective lead or burned out filament. Zero OHMS indicates short circuit.

**8-9.1. Troubleshooting Odometer, Speedometer and Tachometer Circuits**

a. Figure 8-13.1, odometer/speedometer/tachometer wiring diagram, illustrates the electrical circuits of the three instruments. Checkout procedures are tabulated as follows: Odometer - table 8-16. 1; speedometer - table

8-16. 2; and tachometer - table 8-16. 3. To avoid duplication of procedures, the speedometer and odometer checkouts may be run concurrently.

b. Tachometer generator checkout procedure in table 8-16. 3 is applicable only to units with 90° angle drive adapter.

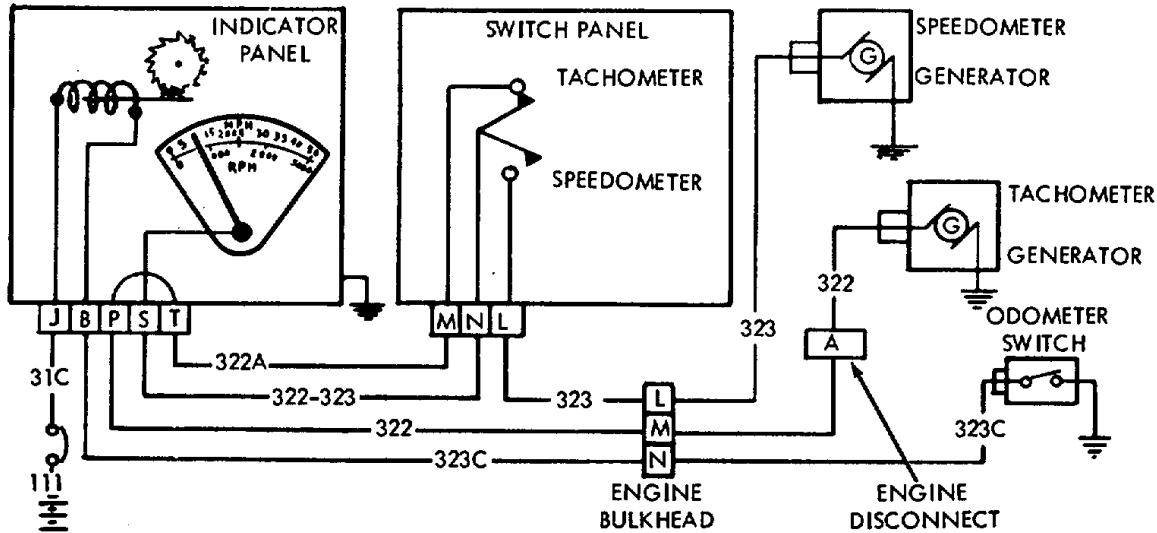

WE 12180

8-13.1. Troubleshooting odometer, speedometer, and tachometer circuits

TABLE 8-16.1. ODOMETER CHECKOUT PROCEDURE

TEST	REMEDY
<p><b>ODOMETER OPERATION ERRATIC OR NO OPERATION</b></p>	
<p>PRELIMINARY STEP - Turn vehicle master switch "ON".</p>	
<p><b>STEP 1</b></p> <div style="border: 1px solid black; padding: 5px; width: fit-content; margin: 10px auto;"> <p>CHECK ODOMETER ELECTRICAL CIRCUIT OPERATION</p> </div> <p>Disconnect speedometer flexible cable at the transmission drive adapter, and drive cable with an electric drill. With a 1725 RPM drill, odometer reading should increase at the rate of 2.3 miles in 5 minutes. With higher RPM drill, mileage indication will increase proportionately.</p> <p>INDICATION NORMAL →</p> <p>LOW OR NO INDICATION ↓</p>	<p style="border: 1px solid black; padding: 10px; width: fit-content;">                     Odometer electrical circuit is functioning properly. Replace transmission adapter assembly (item 1, fig. 9-116).                 </p>

TABLE 8-16. 1. ODOMETER CHECKOUT PROCEDURE (CONT'D)

TEST	REMEDY
<p><b>STEP 2</b> <span style="border: 1px solid black; padding: 2px;">CHECK ODOMETER SWITCH</span></p> <p>Read odometer</p> <p>Disconnect lead #323C from odometer switch and touch it to the hull 91 times. Odometer should advance exactly one mile.</p> <p>INDICATION NORMAL <span style="float: right;">NO GO</span></p> <p>INDICATION BELOW NORMAL</p> <p style="text-align: center;">↓ <b>GO</b></p>	<p>a. Check ground connection between odometer adapter (switch box) and hull. Two external toothed lock-washers must be installed between odometer adapter and hull.</p> <p>b. Replace odometer adapter (figure 9-115).</p> <p>c. Repeat Test Step 1 - If indication is normal, no further service is required.</p>
<p><b>STEP 3</b> <span style="border: 1px solid black; padding: 2px;">CHECK POWER SUPPLY</span></p> <p>Check for power to terminal J of driver's indicator panel.</p> <p>NO POWER <span style="float: right;">NO GO</span></p> <p>NORMAL POWER</p> <p style="text-align: center;">↓ <b>GO</b></p>	<p>a. Check electrical connections at circuit breaker #6, (figures 9-84 and 9-100).</p> <p>b. Check circuit breaker #6, and replace if open.</p> <p>c. Check power supply (circuit #111) to engine bulkhead and to batteries as required.</p> <p>d. Repeat Test Step 1 - If indication is normal, no further service is required.</p>
<p><b>STEP 4</b> <span style="border: 1px solid black; padding: 2px;">CHECK WIRING BETWEEN ODOMETER SWITCH AND INDICATOR PANEL</span></p> <p>Check for:</p> <p>a. Loose or broken connector on lead #323C.</p> <p>b. Poor solder connection at engine bulkhead connector.</p> <p>c. Bent or mis-indexed pins at engine bulkhead or panel connector.</p> <p>d. Poor solder connection at indicator panel plug.</p> <p>DISCREPANCY FOUND <span style="float: right;">NO GO</span></p> <p>NO DISCREPANCY FOUND</p> <p style="text-align: right;">↓ <b>NO GO</b></p>	<p>Correct discrepancy. Repeat Test Step 1 - If indication is normal, no further service is required.</p> <p>Replace indicator panel (figure 9-106). Repeat Test Step 1 - If indication is normal, no further service is required.</p>



TABLE 8-16.2. SPEEDOMETER GENERATOR CHECKOUT PROCEDURE

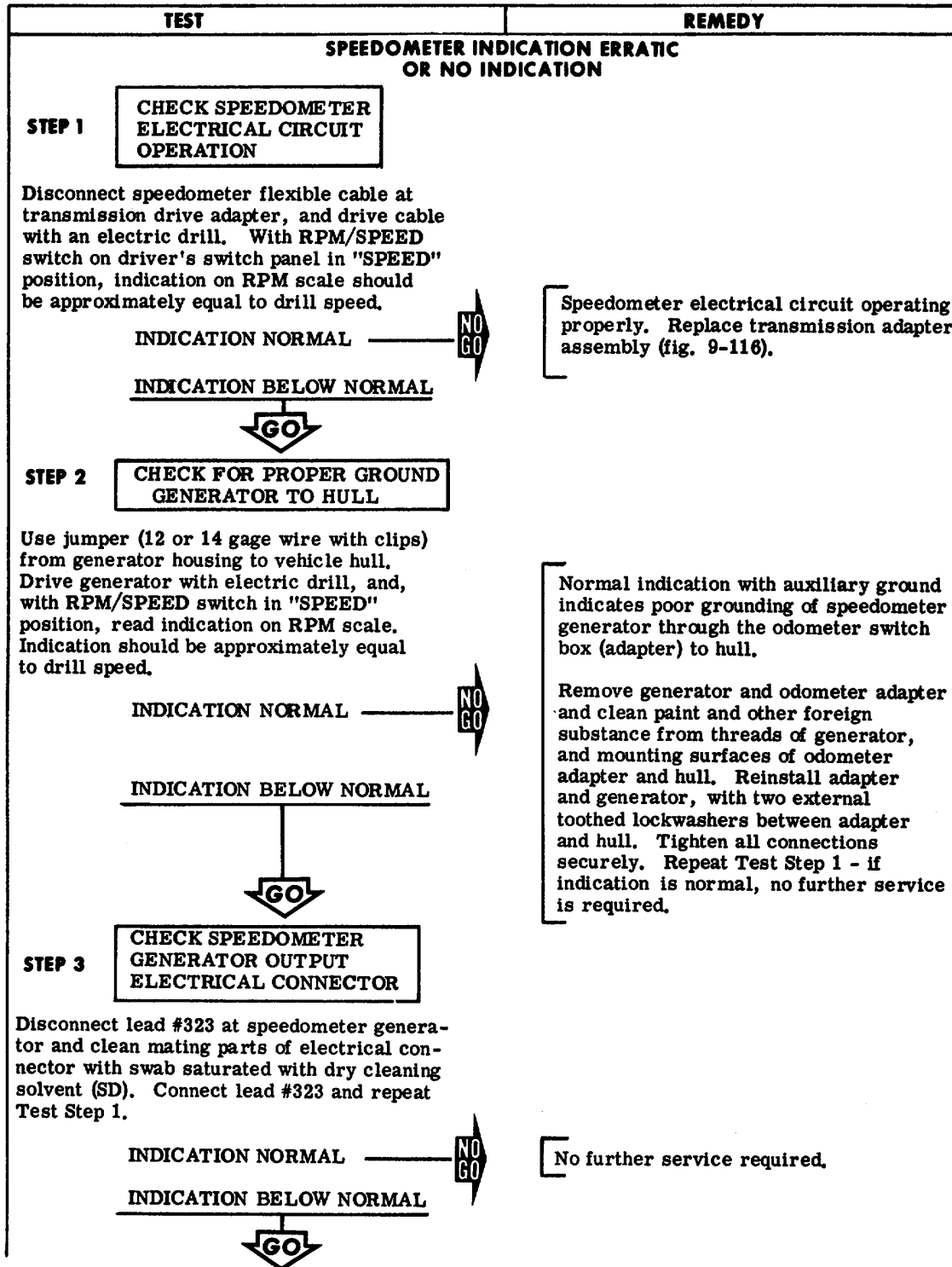

TABLE 8-16.2. SPEEDOMETER GENERATOR CHECKOUT PROCEDURE (CONT'D)

TEST	REMEDY
<p><b>STEP 4</b></p> <p><b>CHECK FOR DEFECTIVE KEY IN GENERATOR DRIVE</b> (Item 13, fig. 9-116)</p> <p>KEY DEFECTIVE OR MISSING</p> <p>KEY IN PLACE AND IN GOOD CONDITION</p> <p style="text-align: center;">↓ <b>GO</b></p>	<p>Replace key (fig. 9-116) with blue or green (later design) key. Repeat Test Step 1. If indication is normal, no further service is required.</p>
<p><b>STEP 5</b></p> <p><b>CHECK GENERATOR OUTPUT</b></p> <p>Disconnect electrical lead #323 from speedometer generator.</p> <p>Drive speedometer cable with electric drill. Voltage (AC) shown between generator connector pin and generator housing should be <math>6 \pm .1</math> volts per 1000 RPM (approx. 10.3 volts for 1725 RPM drill, or 12.3 volts for 2050 RPM drill).</p> <p>OUTPUT BELOW NORMAL</p> <p>OUTPUT NORMAL</p> <p style="text-align: center;">↓ <b>GO</b></p>	<p>Replace speedometer generator (fig. 9-115). Repeat Test Step 1. If indication is normal, no further service is required.</p>
<p><b>STEP 6</b></p> <p><b>CHECK WIRING BETWEEN GENERATOR AND DRIVER'S SWITCH PANEL</b></p> <p>Check for:</p> <ol style="list-style-type: none"> <li>Loose or broken connector on lead #323.</li> <li>Poor solder connection at engine bulkhead connector.</li> <li>Bent or mis-indexed pins in bulkhead or panel connector.</li> </ol> <p>DISCREPANCY FOUND</p> <p>NO DISCREPANCY FOUND</p> <p style="text-align: center;">↓ <b>GO</b></p>	<p>Correct discrepancy. Repeat Test Step 1. If indication is normal, no further service is required.</p>

TABLE 8-16.2 SPPEEDOMETER GENERATOR CHECKOUT PROCEDURE (CONT'D)

TEST	REMEDY
<p><b>STEP 7</b></p> <div style="border: 1px solid black; padding: 5px; width: fit-content; margin: 10px auto;"> <p><b>CHECK RPM/SPEED SWITCH ON DRIVER'S SWITCH PANEL</b></p> </div> <p>Disconnect connector from hull front indicator wiring harness receptacle (fig. 9-101).</p> <p>With switch in "SPEED" position, check continuity between pins L and N of receptacle.</p> <p>NO CONTINUITY → <b>NO GO</b></p> <p>CONTINUITY ↓ <b>GO</b></p>	<div style="border: 1px solid black; padding: 5px; margin: 10px auto; width: 80%;"> <p>Replace switch (fig. 9-102).</p> <p>Repeat Test Step 1. If indication is normal, no further service is required.</p> </div>
<p><b>STEP 8</b></p> <div style="border: 1px solid black; padding: 5px; width: fit-content; margin: 10px auto;"> <p><b>CHECK WIRING BETWEEN SWITCH PANEL AND INDICATOR PANEL</b></p> </div> <p>Check for:</p> <ol style="list-style-type: none"> <li>a. Bent or mis-indexed pins at indicator or switch panel connector.</li> <li>b. Loose ground connection at indicator panel.</li> </ol> <p>DISCREPANCY FOUND → <b>NO GO</b></p> <p>NO DISCREPANCY FOUND → <b>NO GO</b></p>	<div style="border: 1px solid black; padding: 5px; margin: 10px auto; width: 80%;"> <p>Correct discrepancy.</p> <p>Repeat Test Step 1. If indication is normal, no further service is required.</p> </div> <div style="border: 1px solid black; padding: 5px; margin: 10px auto; width: 80%;"> <p>Replace indicator panel (fig. 9-106).</p> <p>Repeat Test Step 1. If indication is normal, no further service is required. If below normal notify support maintenance.</p> </div>

TABLE 8-16.3. TACHOMETER GENERATOR CHECKOUT PROCEDURE

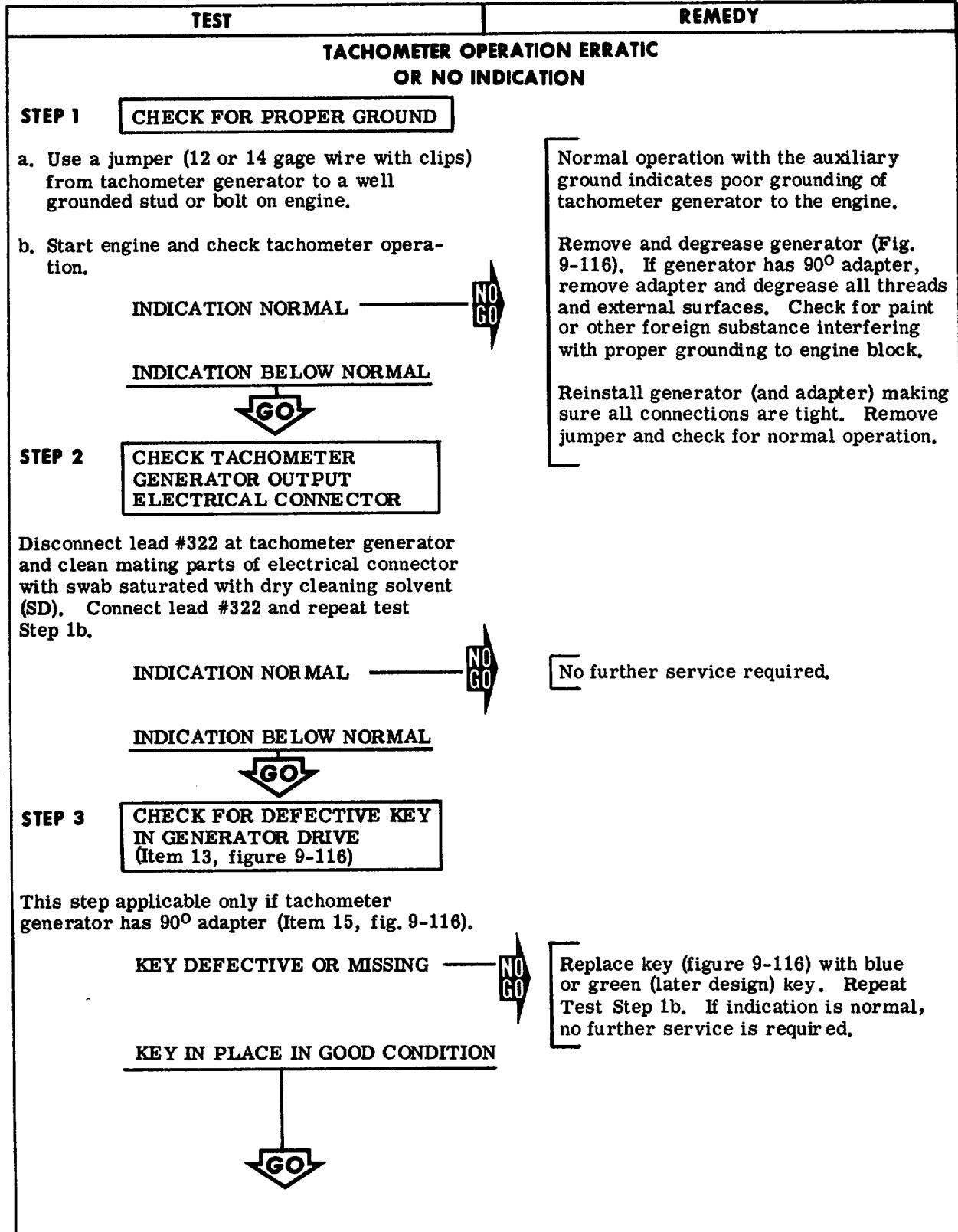

TABLE 8-16.3. TACHOMETER GENERATOR CHECKOUT PROCEDURE (CONT'D)

TEST	REMEDY
<p><b>STEP 4</b>    <b>CHECK GENERATOR OUTPUT</b></p> <p>Disconnect electrical lead #322 and remove tachometer generator from vehicle.</p> <p>Bench test generator by driving it with an electric drill. Voltage (AC) shown between generator connector pin and generator housing should be <math>6 \pm .1</math> volts per 1000 RPM (approx. 10.3 volts for 1725 RPM drill, or 12.3 volts for 2050 RPM drill).</p> <p>OUTPUT BELOW NORMAL ———→ <b>NO GO</b></p> <p>OUTPUT NORMAL ↓ <b>GO</b></p>	<p><b>Replace tachometer generator (fig. 9-115). Check for normal output voltage.</b></p> <p>If output is normal, no further service is required.</p>
<p><b>STEP 5</b>    <b>CHECK TACHOMETER GENERATOR DRIVE SHAFT (Item 22, fig. 9-116)</b></p> <p>Remove generator or 90° adapter and check to see that flexible drive shaft is securely anchored in end of camshaft, and is in good condition.</p> <p>DRIVE SHAFT LOOSE OR DEFECTIVE ———→ <b>NO GO</b></p> <p>DRIVE SHAFT TIGHT AND IN GOOD CONDITION ↓ <b>GO</b></p>	<p><b>Notify support maintenance.</b></p>
<p><b>STEP 6</b>    <b>CHECK 90° ADAPTER DRIVE OUTPUT</b></p> <p>This step applicable only if tachometer generator has 90° adapter (15, fig. 9-116).</p> <p>Turn input side of adapter with screwdriver while visually checking output.</p> <p>DRIVE DEFECTIVE ———→ <b>NO GO</b></p> <p>DRIVE NOT DEFECTIVE ↓ <b>GO</b></p>	<p><b>Replace 90° adapter (figure 9-116). Reinstall generator and check for normal operation (Test Step 1b).</b></p>

TABLE 8-16 .3. TACHOMETER GENERATOR CHECKOUT PROCEDURE (CONT'D)

TEST	REMEDY
<p><b>STEP 7</b></p> <p><b>CHECK WIRING BETWEEN GENERATOR AND DRIVER'S INDICATOR PANEL</b></p> <p>Check for:</p> <ol style="list-style-type: none"> <li>Loose or broken connector on lead #322.</li> <li>Poor solder connections at engine or bulkhead connectors.</li> <li>Bent or mis-indexed pins in engine or bulkhead connectors.</li> <li>Loose ground connection at indicator panel.</li> </ol> <p>DISCREPANCY FOUND → <b>NO GO</b></p> <p>NO DISCREPANCY FOUND → <b>GO</b></p>	<p>Correct discrepancy. Check for normal operation.</p>
<p><b>STEP 8</b></p> <p><b>CHECK RPM/SPEED SWITCH ON DRIVER'S SWITCH PANEL</b></p> <p>Disconnect plug from hull front indicator wiring harness receptacle (figure 9-101).</p> <p>With switch in "RPM" position, check continuity between pins M and N of the receptacle.</p> <p>NO CONTINUITY → <b>NO GO</b></p> <p>CONTINUITY → <b>GO</b></p>	<p>Replace RPM/speed switch (fig. 9-102). Check for normal operation.</p>
<p><b>STEP 9</b></p> <p><b>CHECK WIRING BETWEEN SWITCH PANEL AND INDICATOR PANEL</b></p> <p>Check for:</p> <ol style="list-style-type: none"> <li>Bent or mis-indexed pins at switch panel or indicator panel connectors.</li> <li>Poor solder connections in switch panel receptacle.</li> </ol> <p>DISCREPANCY FOUND → <b>NO GO</b></p> <p>NO DISCREPANCY FOUND → <b>NO GO</b></p>	<p>Correct discrepancy. Reconnect harness and check for normal operation.</p> <p>Replace indicator panel (figure 9-106). Check for normal operation (Test Step 1b) If operation is still abnormal notify support maintenance.</p>

### Section 8-3. ORGANIZATIONAL PREVENTIVE - MAINTENANCE CHECKS AND SERVICES

**NOTE.** All references to M551A1 in this section pertain to vehicles equipped with laser range finder.

#### 8-10. General

a. Preventive-maintenance is the systematic care, inspection, and service of equipment to maintain it in serviceable condition and to detect faults and failures before extensive and time-consuming repairs or replacements are required. The Army system of maintenance pre-scribes two types of preventive-maintenance services which are described in section 4-1 and b below. Refer to TM 38- 750 -for instructions on use of forms pertaining to preventive- maintenance services.

b. Table 8-17 contains the procedures and instructions necessary to perform organizational preventive-maintenance checks and services. These services are performed quarterly or every 750 miles, whichever occurs first, by organizational maintenance with the help of the vehicle crew.

#### 8-11. General Procedures

a. Routine Application. All of the general procedures given in table 8-17 will be followed. Organizational mechanics must be so thoroughly trained in these procedures that they apply them automatically at all times in the performance of their duties.

b. Operational Participation. The crew normally accompanies the vehicle to perform before and/or after services and assist the organizational mechanics in the performance of organizational preventive-maintenance services.

c. services. Organizational services are defined by, and restricted to, the general procedures outlined in table 8-17 unless approval to perform higher category services has been given by the supporting maintenance unit.

Table 8-17. Preventive-Maintenance Checks and Services

Seq no.	Item to be inspected	Procedure	Reference
NORMAL CONDITIONS			
1	Lubrication	<p><i>NOTE. Lubrication should be performed in sequence and conjunction with checks and services listed below. Check the engine and transmission oil levels and coolant level prior to the first check that requires engine operation.</i></p>	LO 9-2350-230-12
SUSPENSION SYSTEM			
2	Road Wheels	<p>a. Check bearing for end play and replace seals where leaks are evident. Tighten nuts and screws to specified torque.</p> <p>b. Replace road wheel if rubber is missing across entire width of wheel for a continuous length of more than 2 inches; chunked or lost for a continuous length greater than 4 inches; or if separation exists between rubber and base metal across entire width of wheel for a continuous length greater than 4 inches.</p> <p>c. Replace road wheel if wear ring is worn through or wheel disk is distorted, broken, or cracked.</p>	FIG 9-61 and 9-64
3	Road Wheel Arms	<p>Check arms and bearings for excessive radial play. Excessive bearing or arm wear results in seal failure and loss of grease.</p>	Fig 9-62, 9-65, and 9-66



Table 8-27. Preventive-Maintenance Checks and Services -  
Continued

Seq no.	Item to be inspected	Procedure	Reference
SUSPENSION SYSTEM - Continued			
4	Shock Absorbers	Check shock absorbers for loose or worn mountings. Tighten loose mounting nuts and bracket screws to specified torque.	Fig 9-74
5	Drive Sprockets	Check sprocket teeth and wheels for wear. Tighten sprocket nuts and screws to specified torque. Reverse the positions of sprocket carrier wheels at 1500 miles, or at second sprocket reversal (whichever occurs first). Place outboard wheels inboard, and vice versa.	Fig 9-72
6	Track Shoes and Pins	Replace damaged or excessively worn track shoes and pins.  <i>NOTE. 50 miles after initial break-in or whenever track pin nuts have been disturbed, retorque track pin retaining nuts to 120-130 ft-lb.</i>	Fig 9-80 and 9-81
HULL (EXTERIOR)			
7	Driving Lights	With the driver assisting, test operation of lights. To check infrared lamps, turn on and place hand on lens; heat will be felt if lights are operating. Replace broken, cracked, or discolored lens and lamps. Adjust headlights if not correctly aimed.  <i>NOTE. Testing of lights will be accomplished only if the tactical situation permits.</i>	Fig 9-86

Table 8-17. Preventive-Maintenance Checks and Services -  
Continued

Seq no.	Item to be Inspected	Procedure	Reference
HULL (EXTERIOR) - Continued			
7.1	Flotation Barrier Stowage Straps	Inspect straps and buttons securing them. Buttons must be welded to the hull, completely around base of button with proper weld penetration. Notify support maintenance if welding is required.	Fig 9-119
8	Surfboard	Adjust surfboard controls.	Fig 9-140
9	Fixed Fire Extinguisher Exterior Control	Check condition of fixed fire extinguisher exterior actuating handle and safety wire.	Fig 5-7
10	Access Plugs	Replace or secure access plugs on underside of hull.	

TABLE 8-17. PREVENTIVE - MAINTENANCE CHECKS AND SERVICES -  
CONTINUED

## QUARTERLY SCHEDULE

## ORGANIZATIONAL MAINTENANCE

Sequence No.	Item to be inspected	Procedure	Reference
10. 1	Exterior Telephone	<p><b>HULL (EXTERIOR) - Continued</b> Make sure wires are securely connected to binding posts. Handset must provide communication with crew and must have radio capability with RAD-TRANS-INT switches in RAD-TRANS position. Replace damaged or worn door gasket.</p>	TM 11-5820-401-10, TM11-5820-498-12,& TM 9-2350-230-25P/1
11	Engine Cooling Unit	<p><b>ENGINE COMPARTMENT</b>  <u>a.</u> Check and clean radiator fins, blow out any accumulation of dirt with compressed air. Replace cracked or broken hoses and tighten hose clamps.  <u>b.</u> Repair or replace coolant pump if leakage is evident.  <u>c.</u> Check coolant pump belt tension.  <u>d.</u> Check antifreeze solution for antifreeze protection, alkalinity, and cleanliness. Service as required to comply with TB 750-651.</p>	Figs. 9-30, 31  Fig. 9-36  Fig. 9-36
12	Engine Connections and Functioning	<p>Tighten loose engine connections and mounting screws. Start engine, observe if it develops adequate cranking speed and starts without excessive noise. Listen for unusual noises in engine and generator that might indicate improper operation or lack of lubrication. Make necessary corrections. Tighten rocker cover screws and exhaust manifold nuts to 35 pounds-feet (engine hot and idling).</p>	
13	Transmission	<p>Check for oil leaks. Tighten transmission trunnion screws. Tighten split-line bolts and nuts:  10 bolts - tighten to 32-37 lb-ft.  2 nuts - tighten to 27-32 lb-ft.</p>	16, Tab. 9-1  Para. 9-7a
14	Transmission Oil Filter	Service.	Fig. 9-40
15	Exhaust Manifold Pipes and Mufflers	<p>Replace damaged or deteriorated exhaust system components. Tighten loose tube clamps and mounting bolts.</p>	Figs. 9-25, 26, 27
15.1	Manifold Elbow	Clean manifold flexible elbow.	Fig. 9-26

8-76.1

TABLE 8-17. PREVENTIVE-MAINTENANCE CHECKS AND SERVICES -  
CONTINUED

## QUARTERLY SCHEDULE

## ORGANIZATIONAL MAINTENANCE

Sequence No.	Item to be inspected	Procedure	Reference
		<b>ENGINE COMPARTMENT - Continued</b>	
16	Generator	Check generator for proper mounting. Fig	9-109, 111
17	Drive Belts	Check drive belts tensioner. Replace belts if pin in rod is within 1/4 inch from bottoming out.	Fig 9-109
18	Starter	Check starter for proper mounting and/or loose connections.	Fig 9-113
19	Air Cleaner	Check air cleaner for proper mounting and condition of ducts and clamps. NOTE. <u>If filter element is wet, replace element or allow to air dry before re-installing.</u>	Fig 5-1, 9-24
19.0	Air Cleaner Pre-cleaner Blower Motors.	With engine running, place hand over air cleaner pre-cleaner discharge elbows to check blower motor air blast.	Fig 9-24.2
19.1	Engine Breather Drain Collector Box	Drain.	Fig 5-3
20	Fuel System	<u>a.</u> Tighten connections that show evidence of leaks. Clean fuel tank filler screens of foreign matter. <u>b.</u> Service fuel filters and replace elements concurrently with engine oil filter replacement. <u>c.</u> Remove water from fuel system by operating drain pump. <u>d.</u> Service fuel tank drain pump filter element.	Fig 9-18, 9-21  Fig 9-17  A, Fig 5-3
21	Bilge Pumps	Check pump mountings and connections. Make sure valves function properly.	Item 15, Fig 9-18 Fig 9-129, 130, 131
22	Engine Air Box (Flame) Heater	<u>a.</u> Check accumulator pressure. <u>b.</u> Check air box (flame) heater and components for mounting and loose connections.	Fig 2-14, 9-16 Fig 9-14, 15
23	Engine Compartment Electrical Components	Examine all exposed electrical controls, terminals, cables, and boxes. Tighten loose connections and mounts. Tape cables that are frayed or have broken insulation.	Fig 9-84, 85
		<b>8-76.2</b>	

TABLE 8-17. PREVENTIVE-MAINTENANCE CHECKS AND SERVICES -  
CONTINUED

## QUARTERLY SCHEDULE

## ORGANIZATIONAL MAINTENANCE

Sequence No.	Item to be inspected	Procedure	Reference
24	Batteries	<p><b>ENGINE COMPARTMENT - Continued</b> Clean batteries, battery supports, retainers, and repaint with acid-resistant paint if corroded. Replace batteries that leak or have cracked cases. Remove caps and clean vents. Test specific gravity with a hydrometer. Tighten and grease terminals and hold-downs carefully to avoid damage to batteries. (TM 9-6140-200-15)</p>	Fig 9-97
25	Fire Extinguisher	<p><b>WARNING: Handle charged cylinders with care.</b> <b>WARNING: Cylinder of crew compartment fire extinguisher becomes a dangerous projectile if accidentally discharged. Cap valve before loosening cylinder mounting screws, and leave cap on until cylinder is securely mounted at installation.</b></p> <p>a. Visually inspect all fire extinguisher mounts, controls, and discharge lines and nozzles. Repair or replace defective components.</p> <p>b. Remove and weigh each fire extinguisher cylinder, and compare with weights stamped on cylinder. If weight loss exceeds 10% of contents (full weight minus empty weight) return cylinder to direct support maintenance for recharging.</p>	Fig 9-139.2  Fig 1-1, 9-139 9-140  Fig 9-139 and 10-42.2
25.1	Power Pack	<p><b>NOTE. Weight of crew compartment cylinder includes cap.</b> Every 6 months (every other "Q" service), remove power pack from hull for inspection. Service power pack components and accessories as required. Clean interior of power pack compartment.</p>	Para 9-1 thru 9-7

TABLE 8-17. PREVENTIVE-MAINTENANCE CHECKS AND SERVICES -  
CONTINUED

## QUARTERLY SCHEDULE

## ORGANIZATIONAL MAINTENANCE

Sequence No.	Item to be inspected	Procedure	Reference
<b>DRIVER'S COMPARTMENT</b>			
26	Personnel Heater	Check heater, control box, and other components for loose connections. Clean fuel filter element and pump filter.	Figs. 9-107, 132,133,134
27	Driver's Seat and Rotatable Hatch	Examine for loose nuts and screws and proper operation	Figs. 9-123, 124, 125
28	Ammunition Racks	Check for broken latches and hinge pins.	Figs. 9-126, 127, 128
29	Bilge Pumps	Check pump mountings and connections. Make sure pump valves function properly.	Figs. 9-129, 130, 131
30	Driver's Switch and Indicator Panels	Check panels for proper mounting and loose connections. Observe for normal readings and operation of gages, instruments, warning lights, and indicator lights. Check selector knob setscrews.	Figs. 9-101, 106
<b>8-78</b>			

Table 8-17. Preventive-Maintenance Checks and Services -  
Continued

QUARTERLY SCHEDULE		ORGANIZATIONAL MAINTENANCE	
Sequence No.	Item to be inspected	Procedure	Reference
		<b>TURRET (EXTERIOR)</b>	
31	Gun-Launcher Tube	<p>Check Equipment Log Book for proper recording of weapon data on DA Form 2408-4, particularly in regard to estimated remaining tube life.</p> <p>Clean. Check for unusual wear, erosion, and damage in bore. Inspect to detect evidence of decoppering and use of unauthorized cleaning materials and methods. Lubricate.</p>	LO 9-2350-230-12
31.1	Stowage Rack Weld Pads	<p>On vehicles equipped with standard turret stowage rack, check that unused weld pads are plugged with screws. If not, clean threads and plug with 21 screws, MS90727-55, to preserve threads.</p>	
32 33	(Deleted) Dust Shield	<p>Check for dents and improper seal.</p>	Fig 11-9
		<b>COMMANDER'S CUPOLA</b>	
34	Hatch Doors and Seals	<p>Check to insure split hatch doors lock securely in all positions and have a watertight seal.</p>	Fig 2-21
35	Cupola Traverse Control Switch Assembly	<p>Check wiring harness connectors. Tape frayed or broken cable insulation.</p>	Fig 2-4
		<b>8-79</b>	

Table 8-17. Preventive-Maintenance Checks and Services -  
Continued

QUARTERLY SCHEDULE ORGANIZATIONAL MAINTENANCE

Sequence No.	Item to be inspected	Procedure	Reference
COMMANDER'S CUPOLA - M551A1 ONLY			
35.1	Electrical Contact Ring	Visually check contact ring for dirt, moisture, and damage. Use cleaning solvent and wipe dry with clean lint-free cloth.	
35.2	Electrical Contact Brush Assemblies	<p>Visually check contact brush assemblies for dirt, moisture, damage, or excessive wear. Depress each brush to make sure it activates properly and does not stick.</p> <p>Clean dirt and debris away with small soft bristle brush and wipe with clean lint-free cloth.</p> <p>Operate cupola drive mechanism by hand and visually check to make sure each contact brush aligns with its proper contact ring track.</p>	
35.3	Index Pointers	Inspect for loose or missing mounting hardware and bent or damaged pointers.	Fig 10-54
35.4	Remote Switch Assembly	<p><u>a.</u> Inspect for loose or missing mounting hardware.</p> <p><u>b.</u> Inspect for loose or damaged toggle switch.</p>	Fig 10-35.3
35.5	Cupola/Laser Control Box Assembly	<p><u>a.</u> Inspect for loose or missing mounting hardware.</p> <p><u>b.</u> Inspect for loose or damaged toggle switches.</p>	Fig 10-35.2
<b>8-80</b>			



Table 8-17. Preventive-Maintenance Checks and Services -  
Continued

QUARTERLY SCHEDULE		ORGANIZATIONAL MAINTENANCE	
Sequence No.	Item to be inspected	Procedure	Reference
COMMANDER'S CUPOLA - M551A1 ONLY - Continued			
35.6	Cupola (Relay) Control Box Assembly	<p><u>c.</u> Inspect for burned out or missing power lamp.</p> <p><u>a.</u> Inspect for loose or missing mounting hardware.</p> <p><u>b.</u> Inspect electrical connector for moisture or damage.</p>	Fig 10-33
35.7	Cupola Drive System Electrical Cable Assembly	<p><u>a.</u> Inspect for damaged or severed wires.</p> <p><u>b.</u> Inspect electrical connectors for moisture, damage, and for proper alignment.</p>	
AUXILIARY EQUIPMENT TO LASER RANGE FINDER - M551A1 ONLY			
35.8	Loader's Periscope Stop	Inspect loader's periscope stop to make sure mounting hardware is tight. Check two stop pins to see if loose or damaged.	Fig 10-54
35.9	Resistor Box Assembly	<p><u>a.</u> Inspect for loose or missing mounting hardware.</p> <p><u>b.</u> Inspect electrical connector for moisture or damage.</p>	Fig 10-35.4
35.10	Laser Control Handle	<p><u>a.</u> Inspect for loose or missing mounting hardware. Fig 10-56</p> <p><u>b.</u> Inspect brow pad lock release for proper operation.</p> <p>Clean and lubricate (OE10), as necessary, to insure locking plungers slide freely.</p> <p style="text-align: center;"><b>8-80.1</b></p>	

Table 8-17. Preventive-Maintenance Checks and Services -  
Continued

## QUARTERLY SCHEDULE

## ORGANIZATIONAL MAINTENANCE

Sequence No.	Item to be inspected	Procedure	Reference
AUXILIARY EQUIPMENT TO LASER RANGE FINDER - M551A1 ONLY - Continued			
35.11	Laser Range Finder External Protective Covers and Cable Covers	Inspect for loose or missing mounting hardware.	Fig 10-57 and 10-58
CAL .50 MACHINE GUN, M2 HB			
Refer to TM 9-1005-213-25.			
36	(Deleted)		
37	(Deleted)		
38	(Deleted)		
CAL .50 MACHINE GUN MOUNT ASSEMBLY			
39	Machine Gun Mount Assembly	With machine gun installed, elevate and depress throughout entire range, Insure all components are intact.	Fig 2-4
Check for ineffectual action in either elevation or depression. If slow or faulty, disassemble, clean, and lubricate.			
Check carefully for cracks or damage to parts. Remove rust and burs with fine emery cloth and file. Paint non-machined surfaces as required.			
TURRET (INTERIOR)			
40	Hatch Seals	Repair or replace damaged or loose hatch seals and protection pads.	Fig 10-44
<b>8-80.2</b>			

Table 8-17. Preventive-Maintenance Checks and Services  
--Continued

QUARTERLY SCHEDULE		ORGANIZATIONAL MAINTENANCE	
Sequence No.	Item to be inspected	Procedure	Reference
TURRET (INTERIOR) -- Continued			
41	Cushions and Backrests	Repair or replace torn cushions and backrests.	Fig 10-39, 10-41, and 10-42
42	Turret Electrical System	Check all connections to insure they are secure. Check selector knob setscrews. Check dome light dimmer switch located at loader's position. If insulating compound is worn or missing from terminals, apply new adhesive MIL-A-46106 (fig 9-95.1).	Fig 10-1
43	Contact Ring and Electrical Cables	Tighten contact ring mounting screws, connectors, and ground lugs. Tape frayed or broken cable insulation.	Fig 10-28
44	Gas-Particulate Filter Unit MSA3	Change particulate filter when contaminated.	Table 2-6 and fig 10-31
152-MM GUN-LAUNCHER AND MOUNT			
45	Mount	Elevate and depress weapon through entire range to note performance.	
46	Buffer	Check counterrecoil buffer for leaks and oil level. Replenish as necessary.	LO 9-2350-230-12
47	Reservoir	a. Check reservoir fittings for-loose connection.	Fig 11-5, 11-7, and
11-8		<b>8-80.3</b>	

Table 8-17. Preventive-Maintenance Checks and Services  
--Continued

QUARTERLY SCHEDULE ORGANIZATIONAL MAINTENANCE

Sequence No.	Item to be inspected	Procedure	Reference
152-MM GUN-LAUNCHER AND MOUNT -- Continued			
47	Reservoir --continued	<p><u>b.</u> Remove and inspect filter. Replace if tears or holes are found in screen. Clean with a regular cleaning solvent (solvent must be clean). Allow screen to air dry. Do not dry screen under air pressure, as damage to screen mesh may result.</p> <p><u>c.</u> Check reservoir fluid level.</p>	
48	Safe to Fire Mechanism	Check mechanism for proper function.	Fig 3-2
49	Breech Assembly	<p>Open and close breech manually and electrically, clean and lubricate. Check all components for unusual wear or cracks. Observe following components for proper operation:</p> <p><u>a.</u> Manual crank handle.</p> <p><u>b.</u> Electric drive motor.</p>	<p>Table 5-8.1</p> <p>A and B, Fig 3-1</p> <p>Steps 10-15, table 3-3</p>
<b>8-80.4</b>			

TABLE 8-17. PREVENTIVE-MAINTENANCE CHECKS AND SERVICES-CONTINUED  
 QUARTERLY SCHEDULE ORGANIZATIONAL MAINTENANCE

Sequence No.	Item to be inspected	Procedure	Reference
<b>152MM GUN-LAUNCHER AND MOUNT - Continued</b>			
49	Breech Assembly - Continued	c. Loading tray and ejector. d. Detent and trigger lever. e. Obturator gasket	Fig 11-20, 21 Fig 11-22, 23 Fig 11-24
50	Electrical Harness and Limit Switches	Check for proper operation and condition,	Fig 11-22, 13, 2
51	Firing Mechanism	Clean contact of firing mechanism with rough cloth or steel wool, 5350-242-4404. Check continuity.	Fig 11-13 Table 11-2
<p style="text-align: center;"><b>NOTE.</b> <u>Service requirements for the firing mechanism are based on usage rather than time. Refer to table 8-17.1.</u></p>			
52	Carrier Cover Vent Plug	Inspect and clean.	Fig 11-25
52.1	Detent, Check Valve, Gun Tube, Coupling, Breech, Compressor, and Related Parts	Service requirements for these items are based on usage rather than time interval. Refer to table 8-17. 1.	
<p style="text-align: center;"><b>CAUTION:</b> <u>Avoid damaging air cylinders. which are under very high pressure.</u></p>			
<p><b>7.62MM MACHINE GUN</b></p>			
<p style="text-align: center;">Checks 53 through 57 deleted. See T.M 9-1005-233-25.</p>			
<p><b>SIGHTING AND FIRE CONTROL</b></p>			
<p style="text-align: center;">NOTE. <u>The purging and charging techniques described in TM 750-116 will be performed on the XM44, M47 and M48 periscopes, M119 Telescope, and M149 Mount when condensation in the instrument is evident or every 90 days. XM44E Series Periscope requires purging at any time head and body are separated.</u></p>			
58	M13A1C Quadrant	a. Inspect for general condition and completeness. Note legibility of scales and indices; clean as required. Check that level vial rotating cover is in a protective position when quadrant is not in use. b. Check for tightness of screws, binding, legibility of scales, condition of level vial and cover. Check adjustment.	B, Fig 2-28
59	XM44 Series Periscope	a. Check synchronization and alignment accuracy of periscope with 152MM gun-launcher. 8-81	Tables 2-9, 11-6

TABLE 8-17. PREVENTIVE-MAINTENANCE CHECKS AND SERVICES - CONTINUED

Sequence No.	Item to be inspected	Procedure	Reference
59	XM44E Series Periscope - Continued	<p><b>SIGHTING AND FIRE CONTROL - Continued</b></p> <p>b. Check for excessive backlash in the periscope and 152MM gun elevation system.</p> <p>c. Inspect wiper blades; replace if necessary. Inspect general condition and completeness. Check operation of knobs and levers. Inspect lens and windows for dirt, cracks, and chips. Check electrical connections. Replace lamps if defective. Check periscope washer fluid reservoir and refill.</p>	Fig. 11-42 Fig. 2-26
59.1	M119 Telescope	<p>Check reticle ground strap connections at conventional reticle elevation knob mounting flange and reticle light holder. Connections must be tight.</p>	
60	M47 and M48 Periscopes	<p>a. Check that all components of the wiper assembly are functioning properly.</p> <p>b. Inspect wiper blades; replace if necessary. Check pump to see that pressure forces fluid from reservoir. Inspect tubing for leaks.</p> <p>c. Check periscope washer fluid reservoir and refill.</p>	Fig. 2-7
61	Cable Assemblies	<p><b>MISSILE SUBSYSTEM UNITS</b></p> <p>Check condition and tightness of all connectors. If replacement of cables is required, notify direct support personnel.</p>	
62	Optical Tracker, Power Supply Modulator, Rate Sensor, Signal Data Converter, and Optical Transmitter	<p>a. Inspect mounting screws and electrical connections. Tighten if necessary.</p> <p>b. Perform transmitter alignment check</p> <p>quarterly or whenever transmitter alignment becomes questionable for any reason.</p> <p>c. Notify support maintenance to perform beam pattern check semiannually.</p>	Fig. 10-20
63	Engine Governed Speed, Performance and No-Load Test	<p><b>ROAD TEST</b></p> <p><b>NOTE.</b> <u>Road test vehicle approximately 3 to 5 miles. When tactical situation does not permit a complete road test, perform the following tests:</u></p> <p>Start engine and warm up. With shift lever in N (neutral) position, fully accelerate engine. Engine should develop 2940 to 2990 rpm. Idle speed should indicate 650-700rpm. Test engine for normal acceleration and power in each transmission range.</p>	

TABLE 8-17. PREVENTIVE-MAINTENANCE CHECKS AND SERVICES - CONTINUED

Sequence No.	Item to be inspected	Procedure	Reference
63	Engine Governed Speed, Performance and No-Load Test - Continued	<p><b>ROAD TEST - Continued</b></p> <p>While testing in low range, accelerate with wide open throttle from low speed to top speed. Listen for unusual noises that might indicate loose, damaged, excessively worn parts, or loose mountings. Repair and adjust linkage if necessary.</p>	
64	Engine and Transmission Stall Test (Based on use of DF-2 fuel, NATOF-54).	<p>Start engine and allow coolant to reach operating temperature (1800 to 2000F). With brake pedal fully depressed, move shift lever to "4" position and fully accelerate engine for a maximum of 15 seconds. The engine should develop 2100 rpm minimum. Failure to attain this speed indicates engine malfunction. If stall speed exceeds 2400 rpm transmission trouble is indicated.</p>	
65	Instruments and Gages	<p>Check instruments for normal indication.</p> <p><b>CAUTION.</b> <u>If gages do not indicate normal readings after engine and transmission have been run long enough to reach normal operating temperature, stop engine and refer to troubleshooting procedure table 8-4).</u></p> <p>Tachometer and Speedometer should operate without excessive fluctuation or unusual noises.</p>	
66	Steering Controls	<p>Move steering T-Bar through its entire range and observe if steering response is satisfactory. With vehicle operating at moderate speed and T-Bar centered, observe if there is any tendency to wander or pull to one side. Repair and adjust linkage if necessary.</p>	Fig. 9-53
67	Transmission	<p>Shift through all ranges, noticing if it shifts smoothly without excessive vibration or unusual noise, and if vehicle response is satisfactory. Compare driver's shift control lever position with position of transmission shift control lever. They should be synchronized in all positions. Repair and adjust linkage if necessary.</p> <p style="text-align: center;"><b>8-83</b></p>	Fig. 9-47

TABLE 8-17. PREVENTIVE-MAINTENANCE CHECKS AND SERVICES - CONTINUED

Sequence No.	Item to be inspected	Procedure	Reference
68	Brakes	<p><b>ROAD TEST - Continued</b></p> <p>Accelerate vehicle to a moderate speed, release accelerator and apply brake, observing if vehicle stops effectively without pulling to one side. With the vehicle stopped on an incline, depress brake pedal and apply parking brake handle. Note if brakes lock securely and vehicle is held in place. Repair and adjust if necessary.</p> <p><b>AFTER ROAD TEST</b></p>	Fig. 9-44
69	Road Wheels, Hubs, and Shock Absorbers	<p>Check temperatures immediately after road test. Refer to "AFTER OPERATION" preventive-maintenance services, table 4-1, step 77.</p>	
70	Vehicle	<p>Visually inspect all areas inside and outside vehicle for evidence of fuel or oil leaks.</p>	
70.1	Engine Mount Screws	<p>Tighten engine mount screws.</p> <p><b>FINAL ROAD TEST</b></p>	Fig. 9-3
71		<p>After all services and inspections have been completed, take the vehicle on a short road test to insure corrections of operational deficiencies. Pay particular attention to those items that were initially defective.</p> <p><b>UNUSUAL CONDITIONS</b></p> <p>Vehicles exposed to extreme-cold or hot weather will require more frequent servicing. Materiel subjected to salt-water immersion should be evacuated to support maintenance unit as soon as possible after exposure.</p> <p><b>EXTREME-COLD WEATHER</b></p>	
72	Cooling System	<p>Test radiator coolant for proper anti-freeze protection.</p>	Par. 9-10
73	Lubricants	<p>Make sure all components are lubricated with correct grade of lubricant for expected temperature.</p> <p style="text-align: center;"><b>8-84</b></p>	App. IV



TABLE 8-17.1. PREVENTIVE MAINTENANCE CHECKS AND SERVICES-  
PRIMARY ARMAMENT AND RELATED EQUIPMENT

INTERVAL	COMPONENT	PROCEDURE	REFERENCE
<b>CAUTION: Avoid damaging air cylinders, which are under very high pressure.</b>			
After each day's firing - not to exceed 40 rounds between cleaning or Every 90 days when not firing	Ammunition detent assembly (Type I or 11 only - para 3-3.4)	Removal/installation (Type ) - - - - - Clean, inspect and repair (Type I) - - - Removal/installation (Type I) - - - - - Disassemble/assemble (Type 1m - - - - Clean, inspect, and repair (Type II) -  <b>NOTE.</b> Where additional firing is not anticipated, remove and clean detent assembly and detent hole for three consecutive days as for cannon tube (LO 9-2350-230-12)	Fig 11-22, Fig 11-23 Fig 11-23.1 Fig 11-23.2 Fig 11-23.3
Not to exceed 100 rounds	Check valve	Disassemble and clean with TPM or RBC.	Fig. 11-10.1, 10.2, 10.3
Not to exceed 200 conventional rounds	Firing mechanism	Disassemble and clean with TPM or RBC. Inspect contact and seal seat on breechblock face.	Fig 11-13
400 Rounds or 30 Compressor hours (More Frequently under dusty conditions)	Compressor Air Intake Strainer	Disassemble and clean with TPM or RBC dry with compressed air. Replace strainer/filter if deteriorated, clogged, or damaged.	Fig. 10-17.4
400 Rounds or 30 compressor hours	Compressor Chemical Dryer	Replace cartridge. <ol style="list-style-type: none"> <li>a. Visually inspect compressor for general physical condition, bent pins, fan blade alignment, deformed tubing, and loose or defective mounting hardware.</li> <li>b. Check oil level with dipstick and add oil if required.</li> </ol>	Fig. 10-17.3
		<p><b>CAUTION:</b></p> <ol style="list-style-type: none"> <li>1. <u>Use extreme care to avoid oil contamination.</u></li> <li>2. <u>Use ONLY air compressor lubricating oil FSN 9150-753-4667.</u></li> <li>3. <u>Do not overfill</u></li> </ol> <ol style="list-style-type: none"> <li>c. Operate compressor (with vehicle engine operating at fast idle, or with auxiliary power source) to check for excessive noise or vibration, and to check operation of moisture separator dump cycle. Moisture separator should shut down compressor and dump accumulated moisture for approximately 10 seconds every 25-35 minutes.</li> </ol>	Fig. 3-2.4

TABLE 8-17.1. PREVENTIVE MAINTENANCE CHECKS AND SERVICES-  
PRIMARY ARMAMENT AND RELATED EQUIPMENT - CONTINUED

INTERVAL	COMPONENT	PROCEDURE	REFERENCE
600 Rounds	Gun Tube, Obturator Seal, Coupling and Breech Chamber	<p>d. Leak-test any disturbed or suspected air connections with liquid soap with system under pressure.</p> <p><b>WARNING:</b> <u>Do not tighten fittings or perform any work on equipment during compressor operation or when system is under pressure. Do not tamper with pressure relief valves.</u></p> <p>Gun tube, obturator seal, coupling and breech chamber are to be replaced as a unit. Notify support maintenance.</p>	
1200 Rounds or 100 Compressor hours	Compressor	<p>a. Remove compressor. Fig. 10-17.1</p> <p>b. Remove dipstick and drain plug to drain nil from compressor sump. Allow approximately 5 minutes to permit oil tubes to drain completely.</p> <p>c. Disconnect oil line at oil strainer adapter. Remove and clean strainer with TPM or RBC and dry with compressed air. Inspect strainer for deterioration or damage and replace if defective.</p> <p>d. If excessive foreign material was evident on strainer or in strainer cavity, it will be necessary to flush sump before refilling.</p> <p>e. Install strainer (with new preformed packing) and connect oil line.</p> <p>f. Install drain plug and fill sump with Air Compressor Lubricating oil. See paragraph 1-6g.1 for correct quantity of oil.</p> <p>g. Install dipstick using new preformed packing.</p> <p>h. Install compressor and leak test all disturbed or suspected connections with liquid soap.</p>	<p>Fig. 10-17.5</p> <p>Fig. 10-17.5</p> <p>Fig.- 10-17.5</p> <p>Fig. 10-17.5</p> <p>Fig. 10-17. 5</p> <p>Fig.10-17.1</p>
8-86			

TABLE 8-17.1. PREVENTIVE MAINTENANCE CHECKS AND SERVICES-  
PRIMARY ARMAMENT AND RELATED EQUIPMENT - CONTINUED

INTERVAL	COMPONENT	PROCEDURE	REFERENCE
Every 30 days when not firing	152MM gun launcher recoil mechanism	<p>a. Assure recoil mechanism is pressurized, and safe to fire indicator is in SAFE position.</p> <p>b. Assure turret travel lock is engaged.</p> <p>c. Using exercising bracket on wrecker boom, position wrecker and M551 vehicle to assure wrecker boom and gun launcher tube are on the same plane and square with each other.</p> <p>NOTE: It may be necessary to position rear of the M551 on an incline and elevate cannon to assure plane alignment, i.e., straight line of wrecker boom and gun launcher:</p> <p>d. Mark a chalk line on the gun launcher tube (or bore evacuator if 81 MQD) 6 to 8 inches forward of dust cover.</p> <p>e. Extend boom of wrecker until wood block of exercising bracket contacts gun launcher muzzle.</p> <p>CAUTION: <u>Assure precise alignment of gun launcher and wrecker boom to prevent component damage.</u></p> <p>f. Extend wrecker boom until gun launcher has been moved out of battery 6 to 8 inches (chalk line) then retreat boom.</p> <p>g. Repeat operation at least 10 times to insure that recoil sliding areas and seals are lubricated.</p> <p>h. Leave recoil mechanism in normal precharged pressure condition.</p>	<p>Fig. 8-14 Fig. 8-15 Fig. 8-16</p>
		8-87	

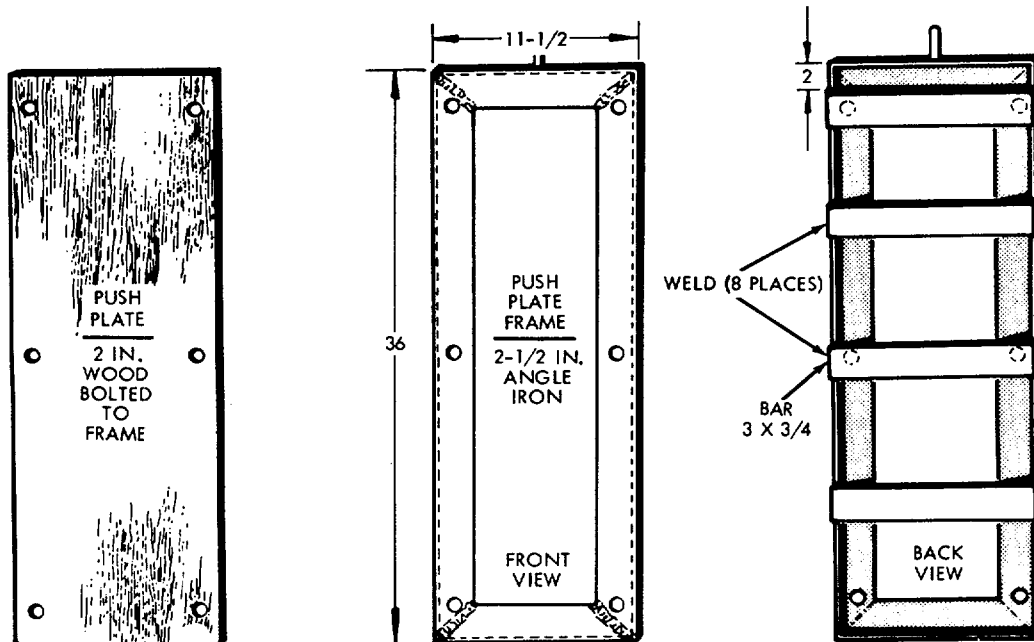
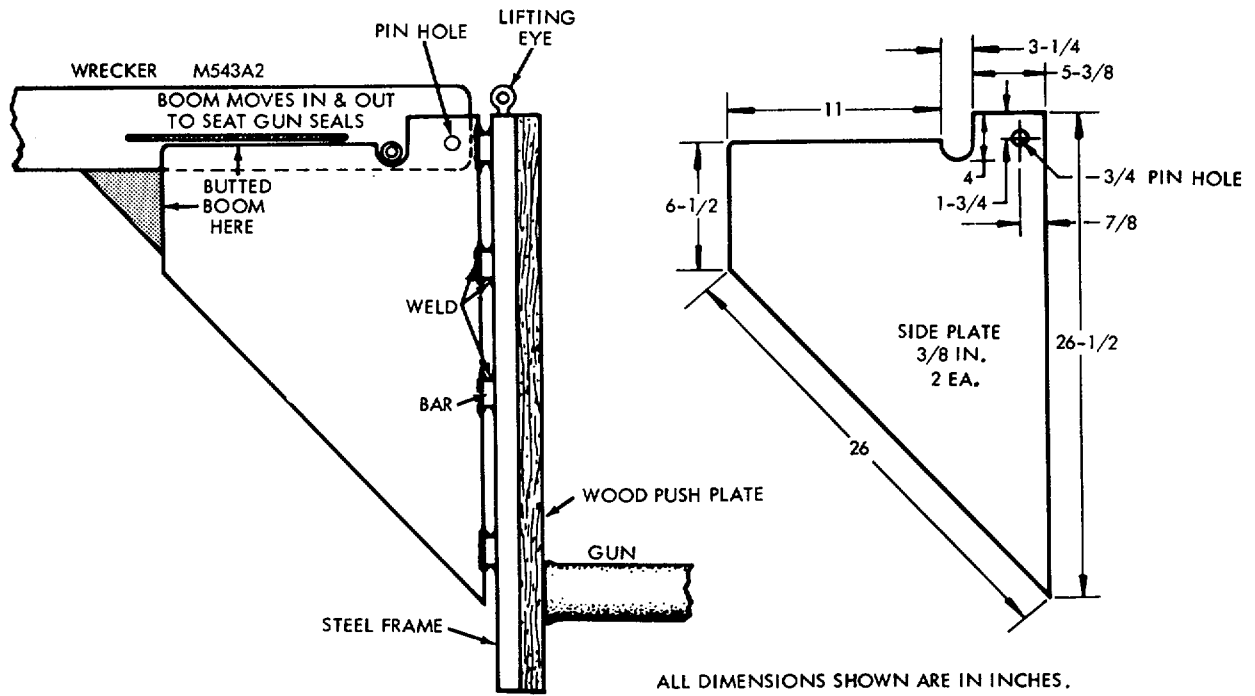

WE 73805

Figure 8-14. Extension bracket for M543A2 wrecker.

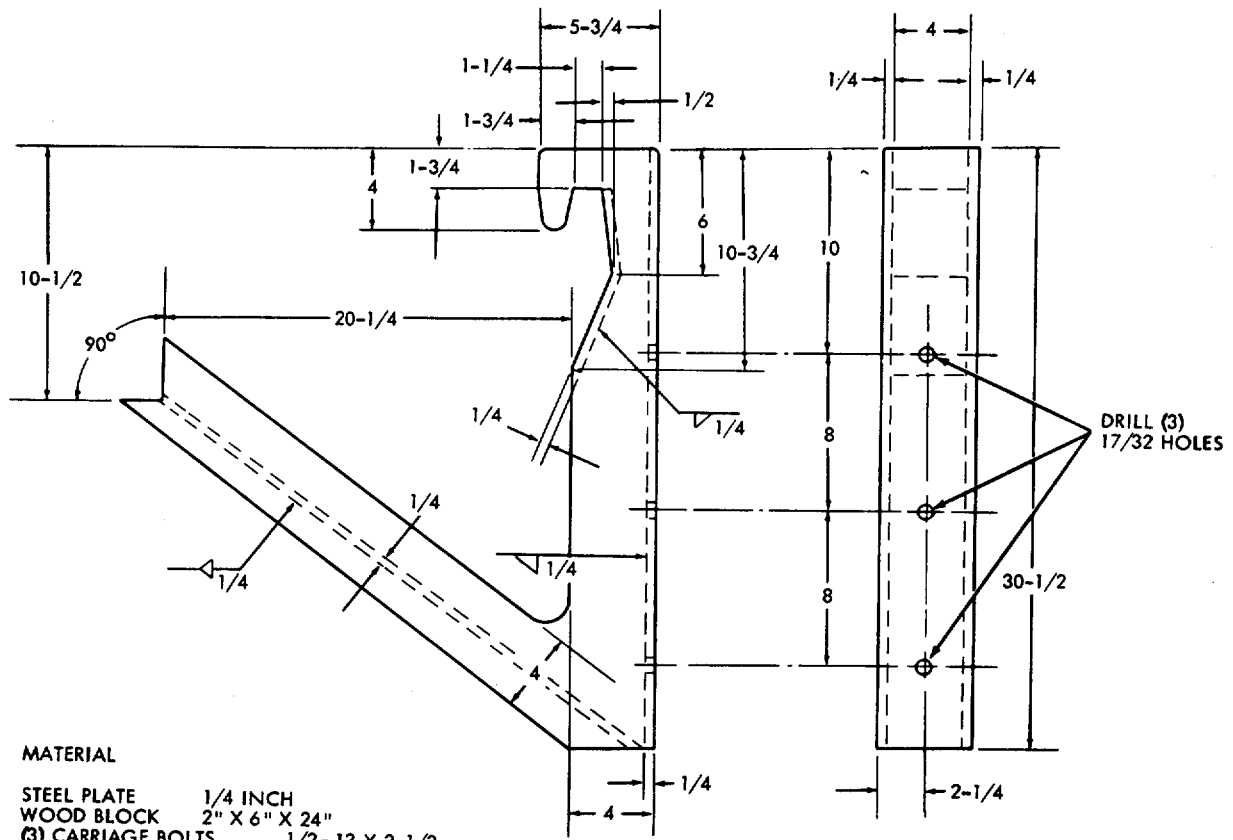

**MATERIAL**

- STEEL PLATE 1/4 INCH
- WOOD BLOCK 2" X 6" X 24"
- (3) CARRIAGE BOLTS 1/2-13 X 2-1/2
- (3) SQUARE NUTS 1/2-13
- (3) SPLIT LOCK WASHERS 1/2 INCH

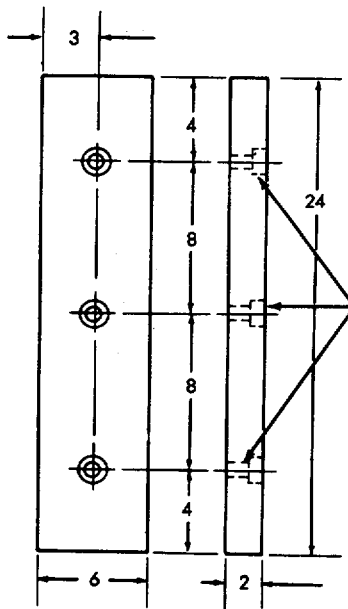

DRILL AND COUNTERSINK  
(3) HOLES FOR 1/2 - 13 X 2-1/2  
CARRIAGE BOLTS

NOTE:  
ALL DIMENSIONS SHOWN  
ARE IN INCHES ± 1/32

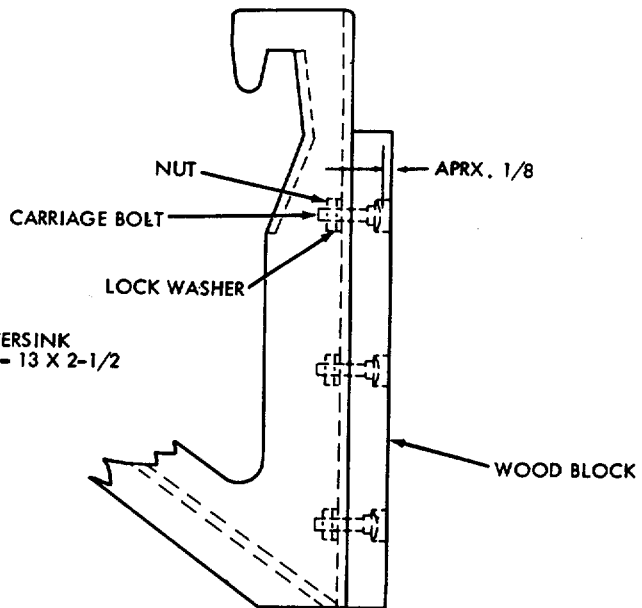

WE 73806

Figure 8-15. Extension bracket for M62 wrecker.

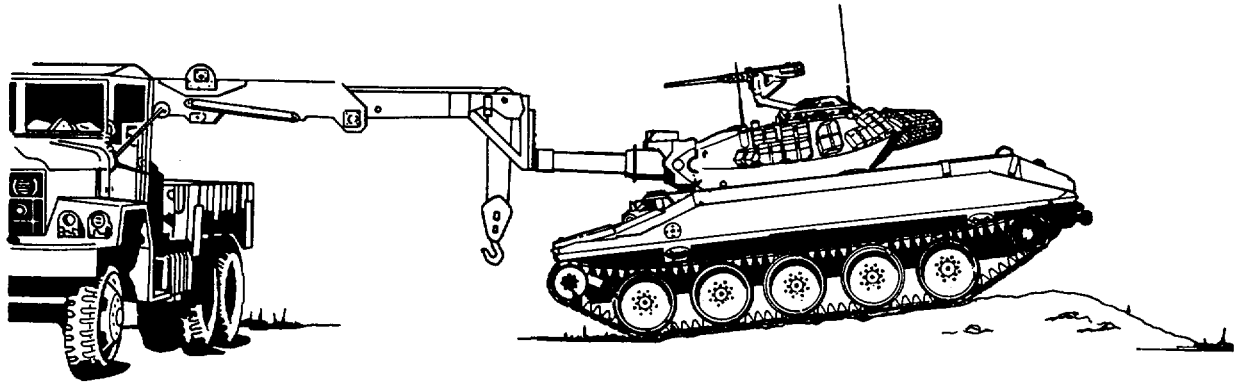

WE 73807

*Figure 8-16. Exercising recoil mechanism on M551 with wrecker.*

## CHAPTER 9 ORGANIZATIONAL MAINTENANCE-POWER PLANT AND HULL

### Section 9-1. POWER PLANT

#### 9-1. General

a. This section contains organizational maintenance procedures for the removal/installation of the power plant, engine mount, and engine mount supports.

#### 9-2. Power Plant Removal Preliminary Preparations

**NOTE.** The power plant removal and installation are to be coordinated with a supporting maintenance unit only if removal is for replacement of engine or transmission. Prior to removal or installation, make certain that all necessary manpower and equipment are available.

a. It is recommended that four men be assigned to the removal and installation of the power plant.

b. The hoisting equipment used to remove and install the power plant should have a minimum lifting capacity of 3500 pounds, minimum reach of 9 feet, and minimum lift of 10 feet. Hoisting equipment should be movable or provisions made to move the vehicle as the power plant is being removed.

c. Allow ample room to work on all sides of power plant after it is removed from vehicle.

#### 9-3. Power Plant Removal Procedure

Four properly trained men can remove the power plant in approximately twenty-five minutes. The removal procedures are sequenced in progressive order and are coordinated for accomplishment by two, two-man teams. Team "one" to accomplish all operations from top of vehicle. Team "two" to accomplish all operations accessible from the ground. Power plant removal sequence is illustrated in figures 9-3 through 9-6.

#### 9-4. Lifting Power Plant From Vehicle (Figure 9-5)

**NOTE.** Proper positioning of the lifting sling is necessary to balance the power plant

to prevent damage to the power plant and/or power plant compartment. Personnel should be stationed at the front, rear, and both sides of the power plant for observation of clearances and to assist during the lifting operation.

a. Lift power plant upwards and to the rear to remove from compartment. Check constantly to maintain clearance during the lifting operations.

b. Test stands or mounting frames should be used if available. However, it is possible to set the power plant on blocks (fig. 9-6), using precautions to avoid any contact with the steel engine oil pan and the coolant crossover tube.

c. Do not drain or disconnect cooling system hoses when removing power plant unless vehicle is equipped with a winterization kit.

#### 9-5. Operating Power Plant When Removed From Vehicle

a. Operation of the power plant, when removed from the vehicle, enables maintenance personnel to inspect the control and drive components by hand-operating the control link-ages on the transmission without any injurious effects to the mechanisms.

b. Special extension fuel input and return hoses, fittings, and wiring harnesses (fig. 9-10) are supplied to facilitate operation of the power plant when removed from vehicle.

**CAUTION:** If power plant is operated while mounted on blocks, watch closely to prevent power plant from vibrating off blocks (fig. 9-6).

#### 9-6. Performing Stall Test

Refer to table 8-17, item 64 for stall test procedures.

#### 9-7. Power Plant Installation Preliminary Preparations

a. Preparation of Power Plant Compartment. With the power plant out of the

vehicle, remove all foreign material from the power plant compartment and wipe all accessible surfaces clean with wiping cloths. Inspect fixed fire extinguisher spray tubes. If power plant compartment is extremely dirty, it may be steam cleaned and/or wiped with a suitable cleaning solvent.

NOTE. Whenever power plant is removed from vehicle, the "split-line" bolts and nuts (attaching transmission converter housing to engine flywheel housing) should be retorqued:

10 bolts - tighten to 32-37 lb-ft.

2 nuts - tighten to 27-32 lb-ft.

b. Power Plant Replacement. Replacement of engine and transmission assemblies will require build-up to a complete power plant before installation in the vehicle. Serviceable components may be removed from the old power plant and installed on the replacement engine and/or transmission assemblies.

c. Engine Replacement. When it is necessary for support maintenance to replace the engine, the following items must be removed from old engine and installed on new engine.

(1) Engine coolant system (figs. 9-28 through 9-35 and 9-38).

(2) Air box engine breather drain collector, tubes, hoses, and fittings (fig. 9-13).

(3) Transmission oil cooler elbows (2) from cooler (fig. 9-12).

(4) Engine oil pressure switch (fig. 9-113).

(5) Fuel shut-off controls and bracket with special screw, fuel shut-off lever (fig. 9-23), governor arm and throttle rod (fig. 9-45).

(6) Generator belt tensioner and bracket (fig. 9-109).

(7) Generator and drive assembly (figs. 9-111, 112). Five screws, washers, and generator mounting bracket. Ground cable and generator/starter-to-voltage regulator electrical harness.

(8) Engine mounts (fig. 9-7).

(9) Main fuel hose quick disconnect, elbow, drain (2), and drain elbow (2) on fuel filters (fig. 9-11).

(10) If replacement engine has serial number previous to 6D-33513, see fig. 9-15.1 for air box heater components which may be removed from old engine for installation on new engine.

(11) Insulation from exhaust manifolds, elbows, and crossover pipe (figs. 9-25 and 9-27).

(12) Tachometer generator (right angle drive only) (figs. 9-115 and 116).

(13) Engine coolant temperature and oil pressure switches and transmitters (fig. 9-114).

(14) Winterization kit inlet and outlet coolant hoses and fittings, if installed.

(15) Support maintenance personnel shall remove power plant harness and crank-shaft pulley from old engine and install on replacement engine.

CAUTION: Discard shipping screw and washer from new engine crank-shaft and reuse screw and washer from old crankshaft, or replace with correct parts (TM 9-2350-230-25P/1).

d. Transmission Replacement. When it is necessary for support maintenance personnel to replace the transmission, the following components must be removed from defective transmission and installed on new transmission by organizational maintenance personnel.

(1) Starter relay and mounting bracket fig. 9-100).

(2) Electrical harness receptacle with bracket (item 7, table 9-1) and power plant harness from transmission.

(3) Transmission oil cooler hoses, oil pressure switch, temperature switch (figs. 9-12, 9-114) and elbows (2), and oil level indicator (fig. 9-41).

(4) Throttle, shift, land steer and water steer control assembly components from transmission. Refer to figures 9-45, 9-46, 9-52 and 9-55.

(5) Brake control components (fig.9-50, 51).



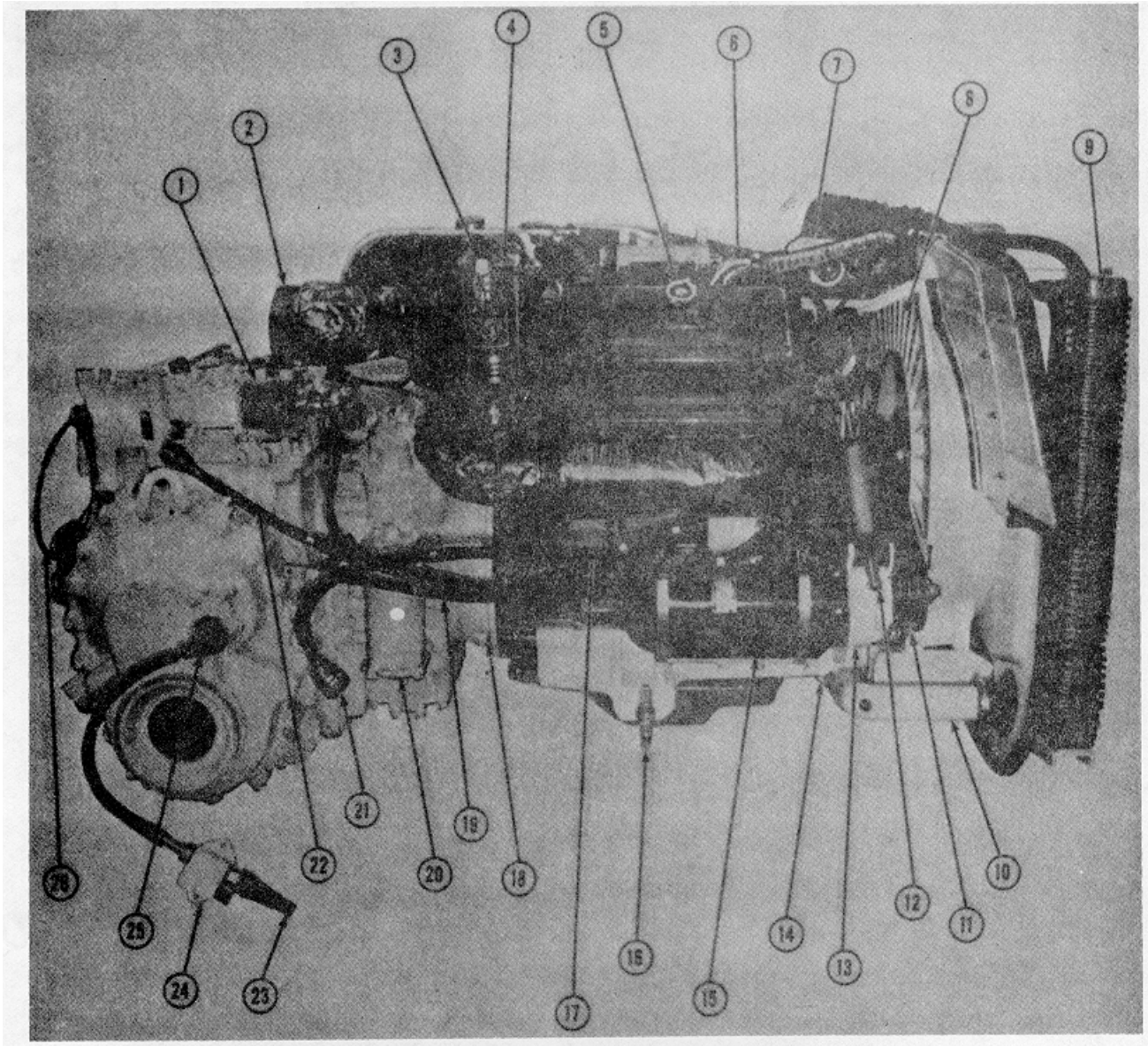

- |                                       |  |
|---------------------------------------|--|
| 1. STARTER RELAY BOX                  | 14. COOLANT DRAIN PLUG                     |
| 2. ENGINE EXHAUST ELBOW               | 15. GENERATOR                              |
| 3. MAIN FUEL HOSE QUICK DISCONNECT    | 16. ENGINE MOUNT SCREW                     |
| 4. PRIMARY FUEL FILTER                | 17. ENGINE STARTER MOTOR                   |
| 5. ENGINE OIL FILLER CAP              | 18. MOUNTING SCREW                         |
| 6. CRANKCASE BREATHER HOSE            | 19. POWER PLANT GROUND CABLE               |
| 7. AIR BOX ACCUMULATOR                | 20. TRANSMISSION OIL FILTER                |
| 8. RADIATOR COOLANT FAN               | 21. GENERATOR-TO-VOLTAGE REGULATOR HARNESS |
| 9. RADIATOR                           | 22. STARTER-TO-BATTERY CABLE               |
| 10. RADIATOR OUTLET TUBE ASSEMBLY     | 23. SPEEDOMETER GENERATOR                  |
| 11. GENERATOR/COOLANT FAN DRIVE BELTS | 24. ODOMETER ADAPTER                       |
| 12. BELT TENSIONER                    | 25. SPEEDOMETER CABLE ADAPTER              |
| 13. GENERATOR DRIVE ASSEMBLY          | 26. BRAKE CABLE                            |

TA0073171

Figure 9-1. Power plant - right side - reference.

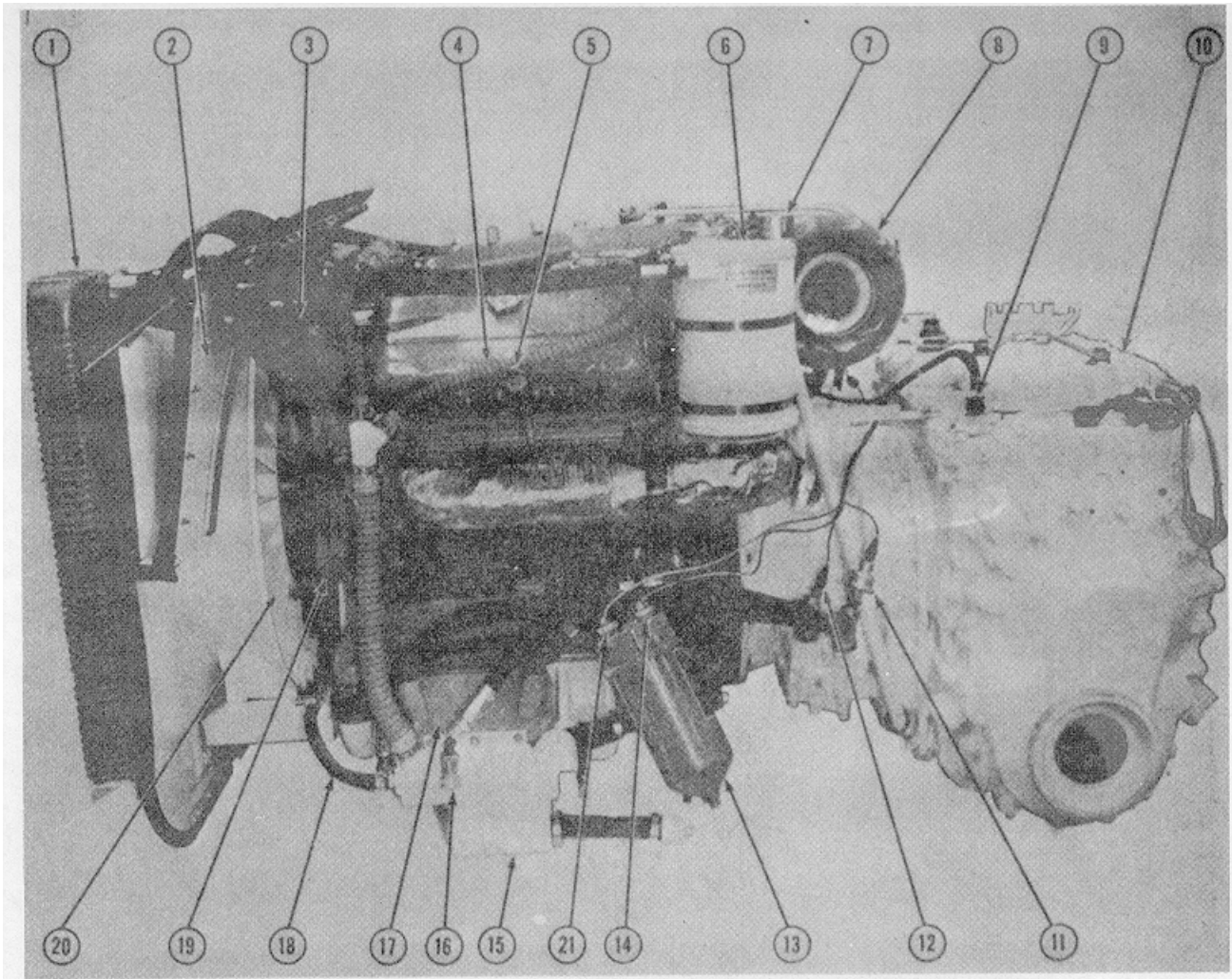

- |                                   |   |
|-----------------------------------|---|
| 1. RADIATOR                       | 11. TRANSMISSION OIL PRESSURE SWITCH                    |
| 2. RADIATOR COOLING FAN SHROUD    | 12. TRANSMISSION OIL TEMPERATURE SWITCH                 |
| 3. INLET THERMOSTAT HOUSING       | 13. ENGINE OIL FILTER                                   |
| 4. ENGINE CRANKCASE BREATHER HOSE | 14. ENGINE OIL LOW PRESSURE SWITCH.                     |
| 5. ENGINE OIL LEVEL GAGE          | 15. ENGINE BREATHER DRAIN COLLECTOR                     |
| 6. COOLANT SURGE TANK             | 16. ENGINE FUEL RETURN HOSE                             |
| 7. TRANSMISSION OIL LEVEL GAGE    | 17. ENGINE/TRANSMISSION OIL COOLER                      |
| 8. TURBOCHARGER                   | 18. AIR BOX DRAIN HOSE                                  |
| 9. ELECTRICAL HARNESS RECEPTACLE  | 19. ENGINE COOLANT PUMP                                 |
| 10. TRANSMISSION                  | 20. RADIATOR COOLANT FAN                                |
|                                   | 21. AIR-CLEANER BLOWER RELAY SWITCH.<br>(OIL PRESSURE). |

TA0073181

Figure 9-2. Power plant - left side - reference.

**PRELIMINARY STEPS BEFORE REMOVING POWER PLANT**

- A. MOVE VEHICLE TO LEVEL GROUND AND WEDGE CHOCK BLOCKS (4 IN. X 4 IN., OR LARGER) AGAINST FRONT AND REAR OF EACH TRACK.
- B. TRAVERSE TURRET TO POSITION GUN AT A 90 DEGREE ANGLE TO LEFT SIDE OF HULL.
- C. TURN MASTER SWITCH "OFF", PLACE TRANSMISSION IN "N" NEUTRAL POSITION, AND RELEASE PARKING BRAKE.
- D. DISCONNECT BATTERY GROUND TERMINAL AND TAPE TERMINAL.

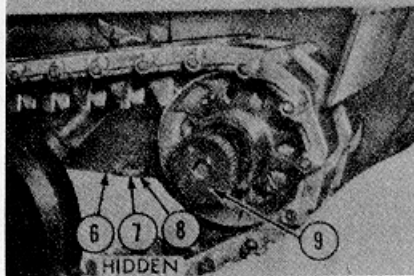
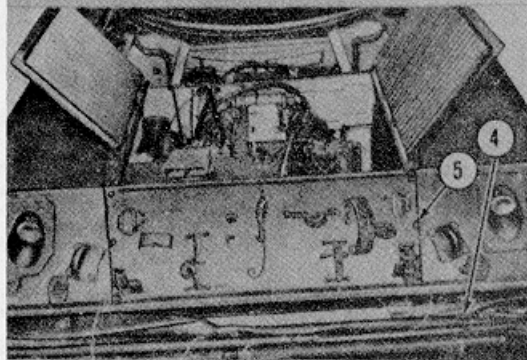
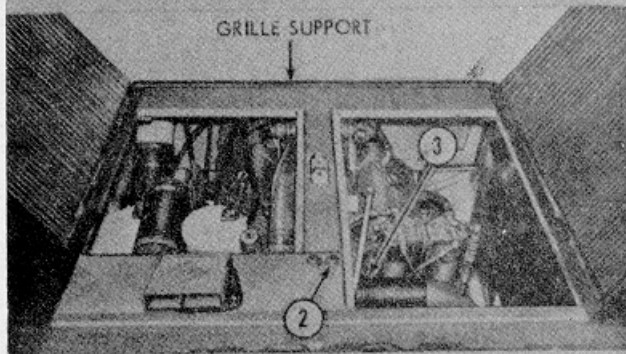

**REMOVAL**

1. REMOVE 6 SCREWS, WASHERS, DEBRIS SCREEN SPACERS AND LIFT OFF AIR INLET GRILLE.

**INSTALLATION NOTE.** TIGHTEN SCREWS TO 90 POUND-FEET.

2. OPEN EXHAUST GRILLES, REMOVE 6 SCREWS, WASHERS, AND GRILLE SUPPORT. DO NOT ALLOW SUPPORT TO DROP ON POWER PLANT. LOWER LEFT SIDE OF SUPPORT 2 IN., AND SLIDE TO LEFT 4 IN. LIFT RIGHT SIDE AND REMOVE FROM VEHICLE.

**INSTALLATION NOTE.** TIGHTEN SCREWS TO 320 POUND-FEET.

3. LOOSEN EXHAUST ELBOW COUPLING AND LEAVE ATTACHED TO TURBOCHARGER.
4. UNBUCKLE 6 FLOTATION COVER STRAPS, OPEN COVERS, PULL FLOTATION BARRIER AND SUPPORTS REARWARD TO REACH LOWER SCREWS.
5. REMOVE 17 SCREWS AND WASHERS.

**INSTALLATION NOTE.** TIGHTEN SCREWS TO 90 POUND-FEET.

SEPARATE EXHAUST ELBOW COUPLING WITH SCREWDRIVER AND LIFT OFF ENGINE ACCESS COVER WITH MUFFLER. SET COVER ON BLOCKS TO PREVENT MUFFLER DAMAGE.

**CAUTION:** ENGINE ACCESS COVER IS HEAVY. USE POWER PLANT SLING - 4910-907-8990. LIFT COVER STRAIGHT UP AND GUIDE EXHAUST ELBOW PAST THROTTLE ROD. COVER TURBOCHARGER OPENING TO PREVENT ENTRY OF FOREIGN MATERIAL.

6. REMOVE 2 HULL BOTTOM ACCESS PLUGS BELOW ENGINE MOUNTS. SEE FIG. 5-7. REPLACE PREFORMED PACKING IF WORN OR DAMAGED.
7. TURN ENGINE MOUNT SCREWS (FIG. 5-7) COUNTER-CLOCKWISE TO LOOSEN.

**INSTALLATION NOTE.** CLEAN SCREWS, LUBRICATE WITH HIGH TEMPERATURE OIL AND TIGHTEN TO 175 POUND-FEET.

8. REMOVE AIR BOX/BREATHER DRAIN COLLECTOR DRAIN HOSE FROM CLIP ON LEFT HULL FLOOR (FIG. 5-3).
9. PULL DRIVE SHAFTS FROM BOTH SPROCKET HUBS (FIG. 9-71).

**INSTALLATION NOTE.** APPLY A LIGHT COAT OF GAA GREASE TO SPLINES ON BOTH ENDS OF SHAFT. APPLY A LIGHT COATING OF NON-HARDENING GASKET MATERIAL TO CONTACT SURFACE OF COVER. TIGHTEN SCREWS TO 35 POUND-FEET.

**INSTALLATION**

REVERSE REMOVAL PROCEDURE.

TA007319

Figure 9-3. Removal/installation - power plant (1 of 4)



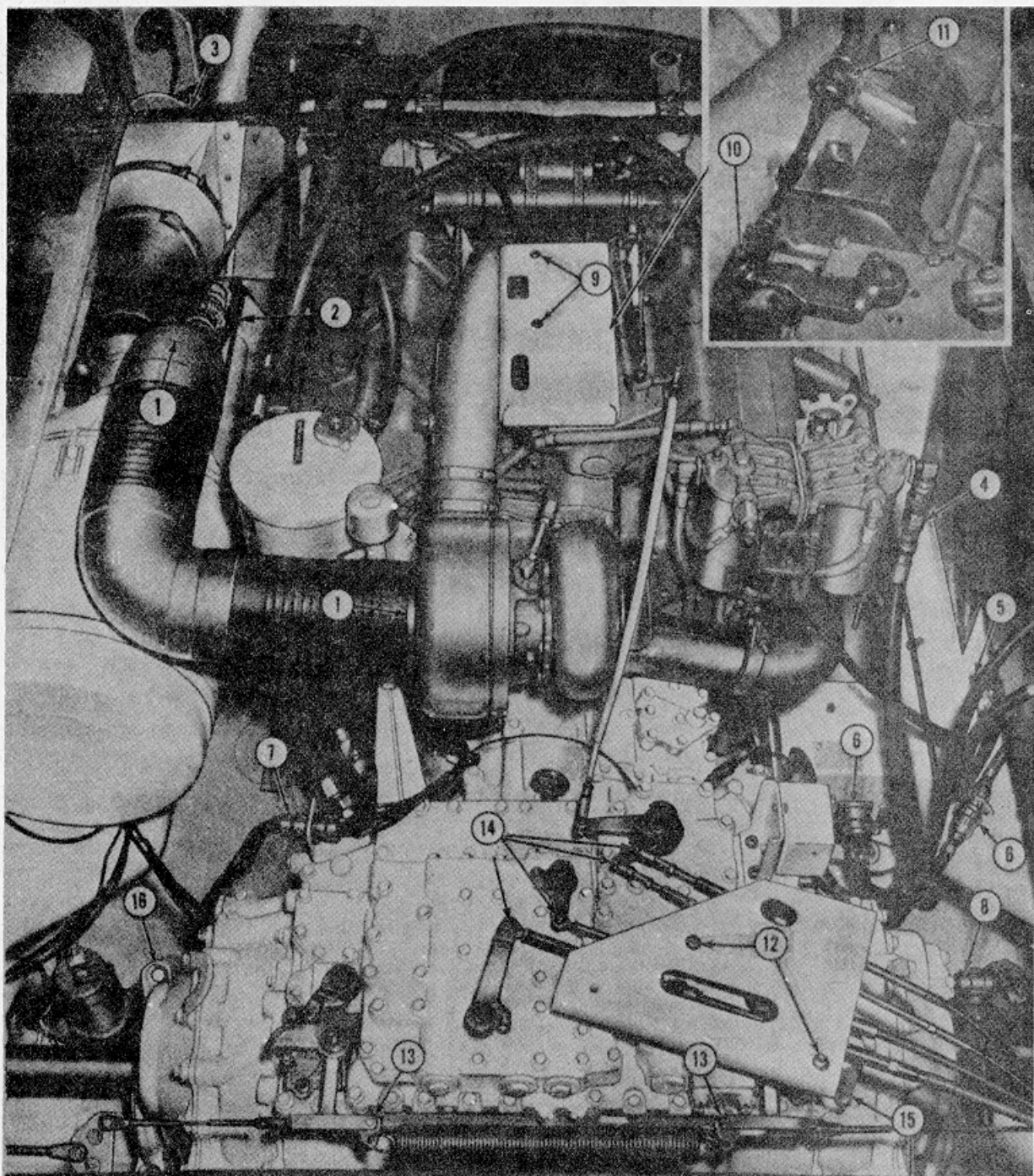

POWER PLANT REMOVAL DISCONNECT POINTS

REMOVAL FOLLOW NUMERICAL SEQUENCE (TABLE 9-1).

INSTALLATION REVERSE REMOVAL PROCEDURE. REFER TO SUPPORTING MAINTENANCE FOR PROPER ADJUSTMENT OF GOVERNOR IDLE SPEED.

DO NOT REMOVE  
CABLES FROM  
BRACKET WHEN  
REMOVING POWER  
PLANT

TA007320

Figure 9-4. Removal/installation - power plant (2 of 4)

TABLE 9-1. REMOVAL/INSTALLATION - POWER PLANT (FIGURE 9-4)

STEP	PROCEDURE
1	Loosen clamps (2) on air cleaner duct and remove duct. Cover turbocharger and air cleaner openings to keep out foreign matter. <b>INSTALLATION NOTE.</b> <u>Tighten clamps to 50-60 pounds-inch.</u>
2	Disengage return fuel line at quick disconnect and place hose on engine.
3	REMOVE 2 SCREWS, WASHERS, NUTS, AND RETAINER FROM LEFT SIDE OF SHROUD.
4	Disconnect main fuel line at quick disconnect and place hose clear of power plant.
5	Remove 2 screws, washers, and ground cable from hull and replace screws and washers in hull Place cable on power plant.
6	Disconnect generator cable from voltage regulator and starter cable at slope plate bracket. Place cables on power plant.
7	Unscrew nut, disconnect power plant harness and place harness clear of power plant.
8	Unscrew nut and remove speedometer adapter and adapter key (1 and 4, fig. 9-116).  <b>NOTE.</b> <u>Tape adapter key to speedometer cable to prevent loss.</u>
9	Remove 2 screws, washers, and step plate from top of engine. <b>INSTALLATION NOTE.</b> <u>Tighten screws to 35 pounds-feet.</u>
10	Remove cotter pin and clevis pin from fuel shut-off clevis.
11	Loosen jam nuts and remove fuel shut-off cable at bracket. Remove clamp from shroud and place cable clear of engine. Install step plate and temporarily install screws and washers (step 9). <b>INSTALLATION NOTE.</b> <u>See Figure 9-22 for fuel shut-off adjustment.</u>
12	Remove 2 screws, washers, and protective plate.
13	Remove cotter pins and clevis pins from both brake cable clevises and remove brake cable from transmission.
14	Remove 4 cotter pins and clevis pins, then disconnect land steer, water steer, throttle, and shift linkage. <b>INSTALLATION NOTE.</b> <u>See Figures 9-45, 46, 52, and 55.</u>
15	Remove 3 control bracket screws and lift bracket with control cables from transmission and stow on rear hull slope, clear of power plant. If control cables are removed from transmission control cable support bracket, refer to figures 9-44, 9-47, 9-53 and 9-54 for proper adjustment.  <b>INSTALLATION NOTE.</b> <u>Tighten screws to 20 to 24 pounds-feet.</u>
16	Remove 2 screws and trunnion mount caps from each side of transmission. Mark trunnion caps right and left, front and rear, to facilitate installation. <b>INSTALLATION NOTE.</b> <u>Make certain trunnion inserts are properly in place before installing power plant. Tighten trunnion mount cap screws to 85-90 pounds-feet.</u>

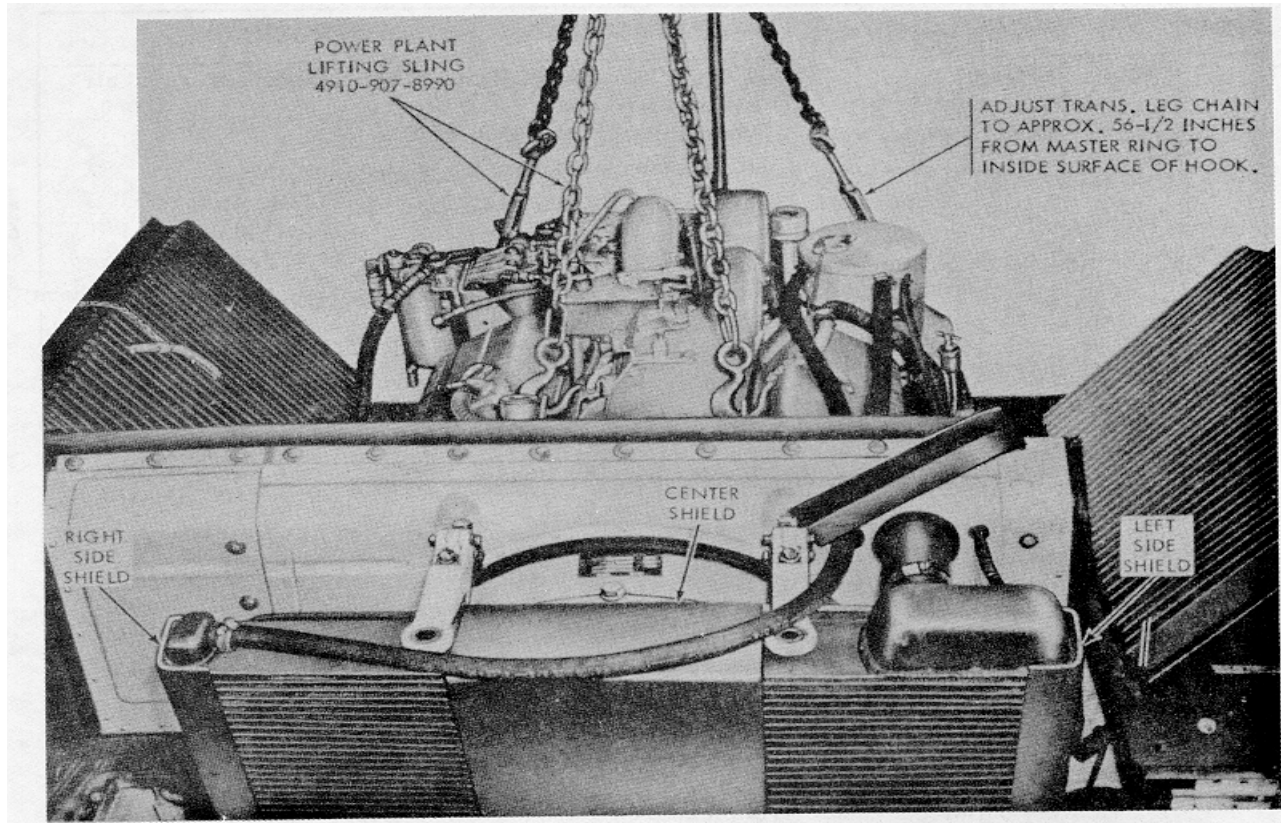

**CAUTION:** ON VEHICLES EQUIPPED WITH WINTERIZATION KIT, DRAIN COOLANT SYSTEM (TABLE 5-4) AND DISCONNECT UPPER AND LOWER ENGINE HOSES TO WINTERIZATION KIT COOLANT AND BATTERY HEATER FITTINGS.

INSTALL SHIELDS ON FRONT AND BOTH SIDES OF RADIATOR.

ATTACH LIFTING SLING TO POWER PLANT AT FOUR (4) PLACES. OBSERVE AND ADJUST TURN BUCKLES, IF NECESSARY, TO RAISE POWER PLANT AS LEVEL AS POSSIBLE. SLOWLY LIFT POWER PLANT FROM VEHICLE.

**CAUTION:** DURING POWER PLANT REMOVAL OR INSTALLATION USE EXTREME CARE TO PREVENT DAMAGE TO TORSION BARS.

WATCH RADIATOR, ENGINE COMPONENTS, AND ALL SIDES OF POWER PLANT TO BE SURE THEY CLEAR HULL, AIR CLEANER, AND OTHER PERMANENTLY INSTALLED COMPONENTS.

PLACE POWER PLANT ON APPROPRIATE STAND OR SUITABLE WOOD BLOCKS (FIG. 9-6).

INSTALLATION NOTE. BE SURE TO REMOVE ALL RADIATOR SHIELDS AFTER INSTALLING POWER PLANT IN VEHICLE.

NOTE. ALL DIMENSIONS SHOWN ARE IN INCHES.

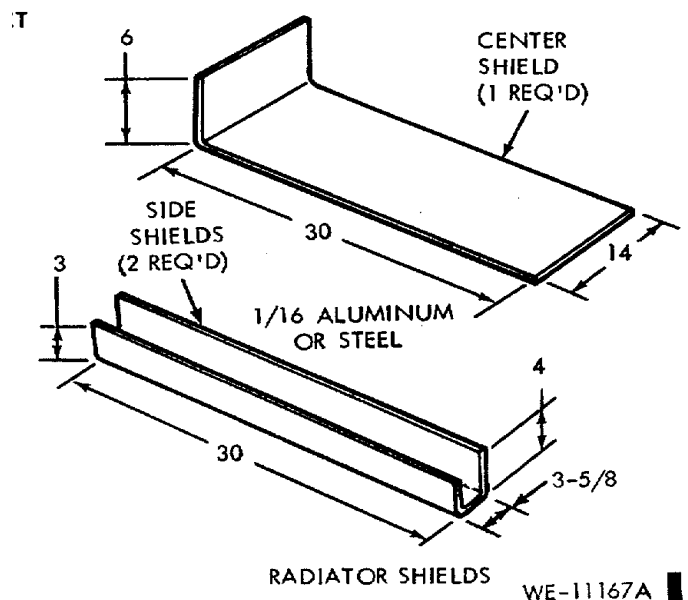
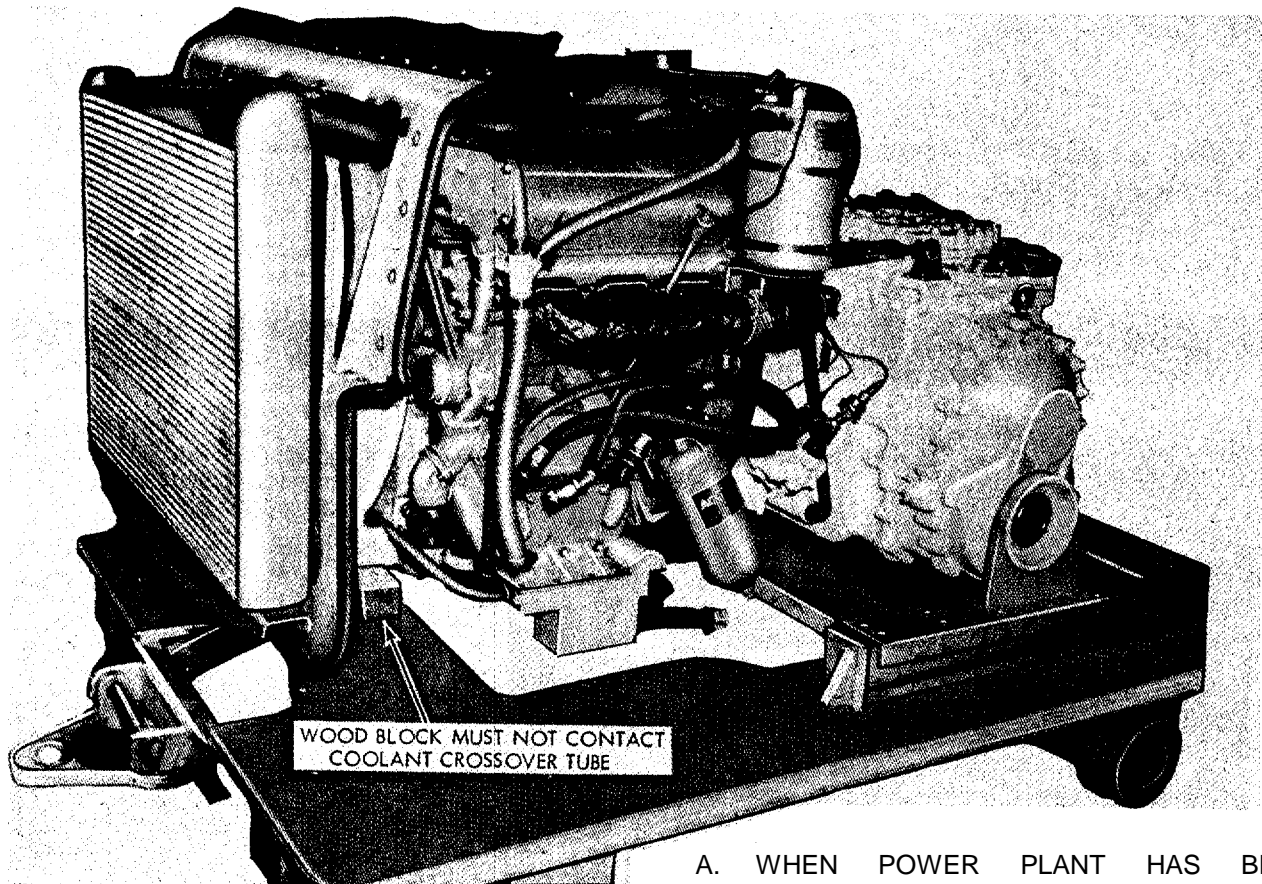
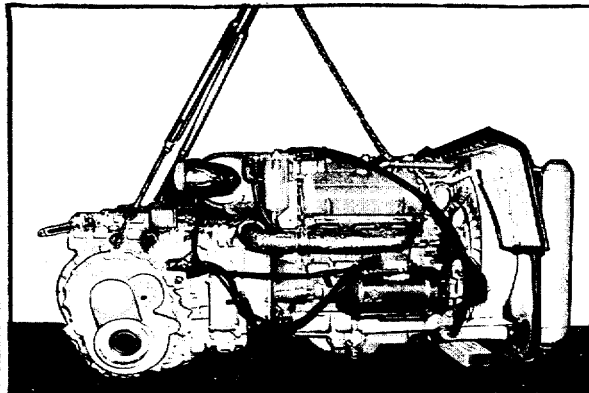

Figure 9-5. Removal/installation - power plant (3 of 4)



- A. WHEN POWER PLANT HAS BEEN REMOVED FROM VEHICLE, PLACE ON SUITABLE STAND WHICH WILL ALLOW AMPLE WORKING AREA ON ALL SIDES OF POWER PLANT.



- B. POWER PLANT MAY BE SET ON CLEAN HARD SURFACE. SUPPORT FRONT OF POWER PLANT WITH 4 X 4 WOOD BLOCK PLACED BENEATH RADIATOR SUPPORT AS SHOWN. BLOCK MUST NOT CONTACT COOLANT CROSSOVER TUBE

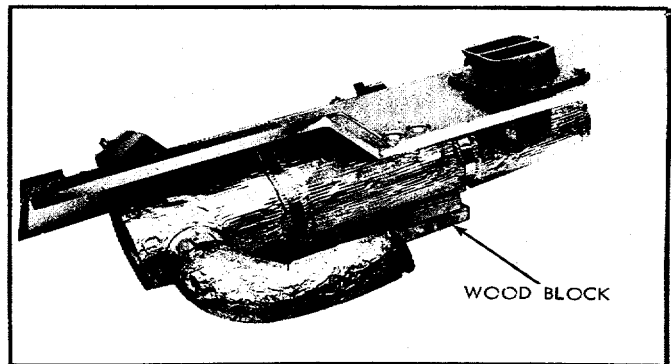

- C. PLACE MUFFLER ON BLOCK TO PREVENT DAMAGE TO EXHAUST ELBOW. (NOT REQUIRED IF ENGINE ACCESS COVER HAS BUILT-IN MUFFLER GUARD.)

WE 12173

Figure 9-6. Removal/installation - power plant (4 of 4)

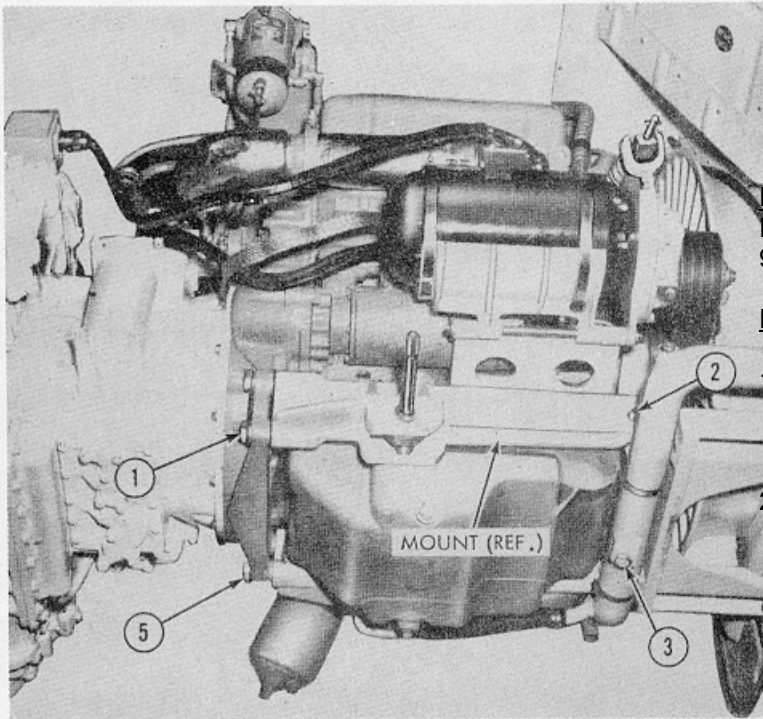

PRELIMINARY STEPS

REMOVE POWER PLANT FROM VEHICLE (FIGURES 9-3 THROUGH 9-6).

REMOVAL - RIGHT MOUNT

1. REMOVE 2 SCREWS, LOCK PLATE AND FLAT WASHERS FROM REAR OF RIGHT ENGINE MOUNT ASSEMBLY.
2. REMOVE 2 SCREWS, LOCK PLATE, FLAT WASHERS, AND ENGINE MOUNT ASSEMBLY FROM RIGHT SIDE OF ENGINE.

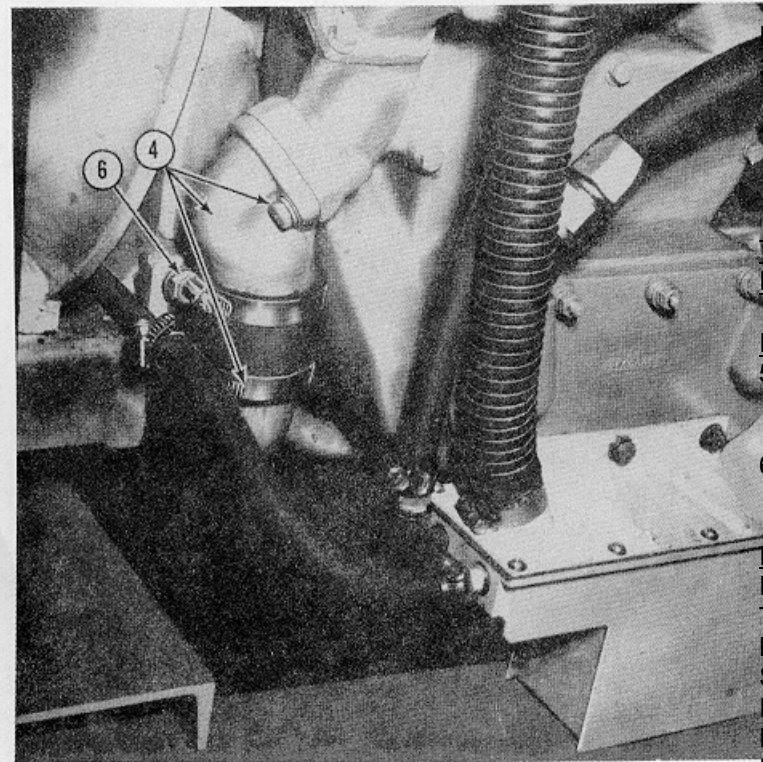

REMOVAL - LEFT MOUNT

3. DRAIN ENGINE COOLANT SYSTEM.
  4. REMOVE 2 SCREWS, FLAT WASHERS, LOWER HOSE CLAMP AND COOLANT PUMP INLET ELBOW, GASKET, AND HOSE.
- CAUTION:** DO NOT PRY HOSES OFF TUBES AS TUBE ENDS MAY BE DAMAGED AND LEAKS RESULT.

**INSTALLATION NOTE.** USE NEW GASKET AT INSTALLATION.

5. REMOVE 2 SCREWS, LOCK PLATE AND FLAT WASHERS FROM REAR OF LEFT ENGINE MOUNT ASSEMBLY.
6. REMOVE 2 SCREWS, LOCK PLATE, FLAT WASHERS AND THE ENGINE LEFT MOUNT ASSEMBLY.

INSTALLATION

REVERSE REMOVAL PROCEDURE. ITEMS 1 AND 5: TIGHTEN SCREWS TO 250-300 POUND-FEET AND BEND CORNERS OF LOCK PLATE TO LOCK SCREWS.

ITEMS 2 AND 6: TIGHTEN SCREWS TO 100-120 POUND-FEET AND BEND CORNERS OF LOCK PLATE TO LOCK SCREWS.

WE 66677

Figure 9-7. Removal/installation - engine mount assembly  
9-10



**REMOVAL**

REMOVE 4 SCREWS, 2 SUPPORTS, 8 MOUNTS, AND 8 FLAT WASHERS FROM FLOOR OF POWER PLANT COMPARTMENT.

**INSTALLATION**

ASSEMBLE SCREWS, MOUNTS, AND FLAT WASHERS ON SUPPORT AS SHOWN IN VIEW B. POSITION ENGINE MOUNTS ON FLOOR OF POWER PLANT COMPARTMENT THEN TIGHTEN 4 SCREWS TO 180 POUNDS-FEET.

**CAUTION:** EXTREME CARE MUST BE TAKEN WHILE WORKING IN THE POWER PLANT COMPARTMENT TO PREVENT DAMAGE TO TORSION BARS.

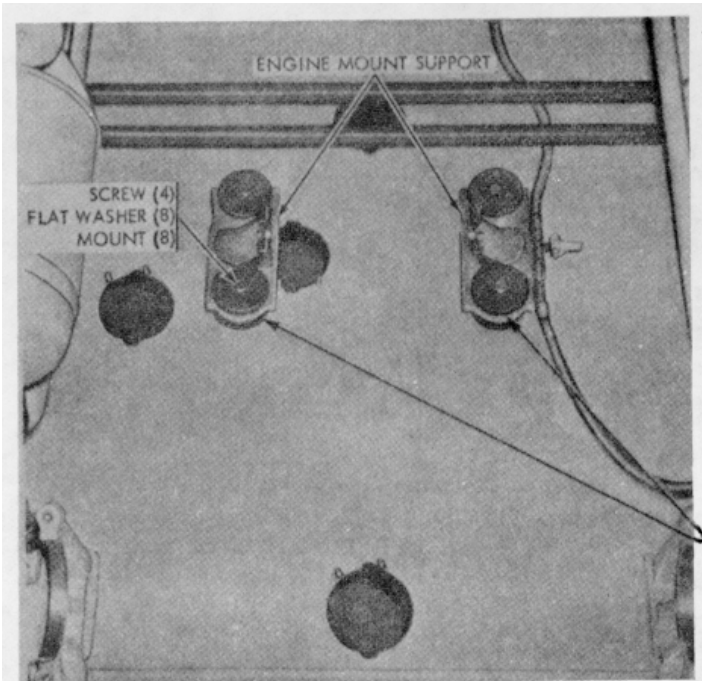

A-ENGINE MOUNT - INSTALLED

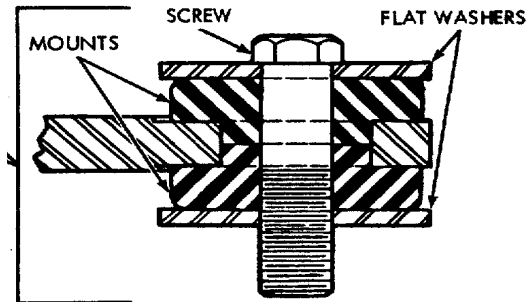

B - ENGINE MOUNT ASSEMBLY. TA007321

Figure 9-8. Removal/installation - engine mount supports

**DISASSEMBLY**

FOLLOW NUMERICAL SEQUENCE

1. SPRING PIN
2. WASHER (2)
3. PLUNGER
4. SCREW
5. NUT
6. MOUNT

**ASSEMBLY**

REVERSE DISASSEMBLY PROCEDURE

REPLACE UNSERVICEABLE ITEMS AS REQUIRED

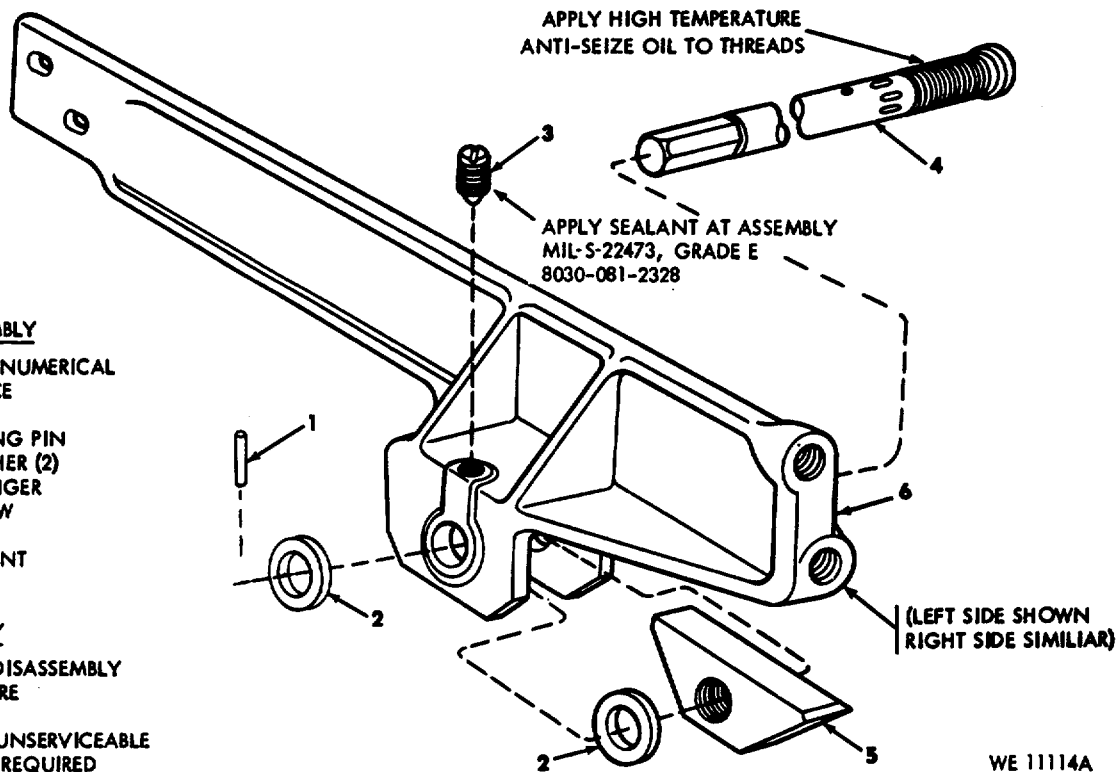

WE 11114A

Figure 9-9. Disassembly/assembly/repair-engine mount assembly

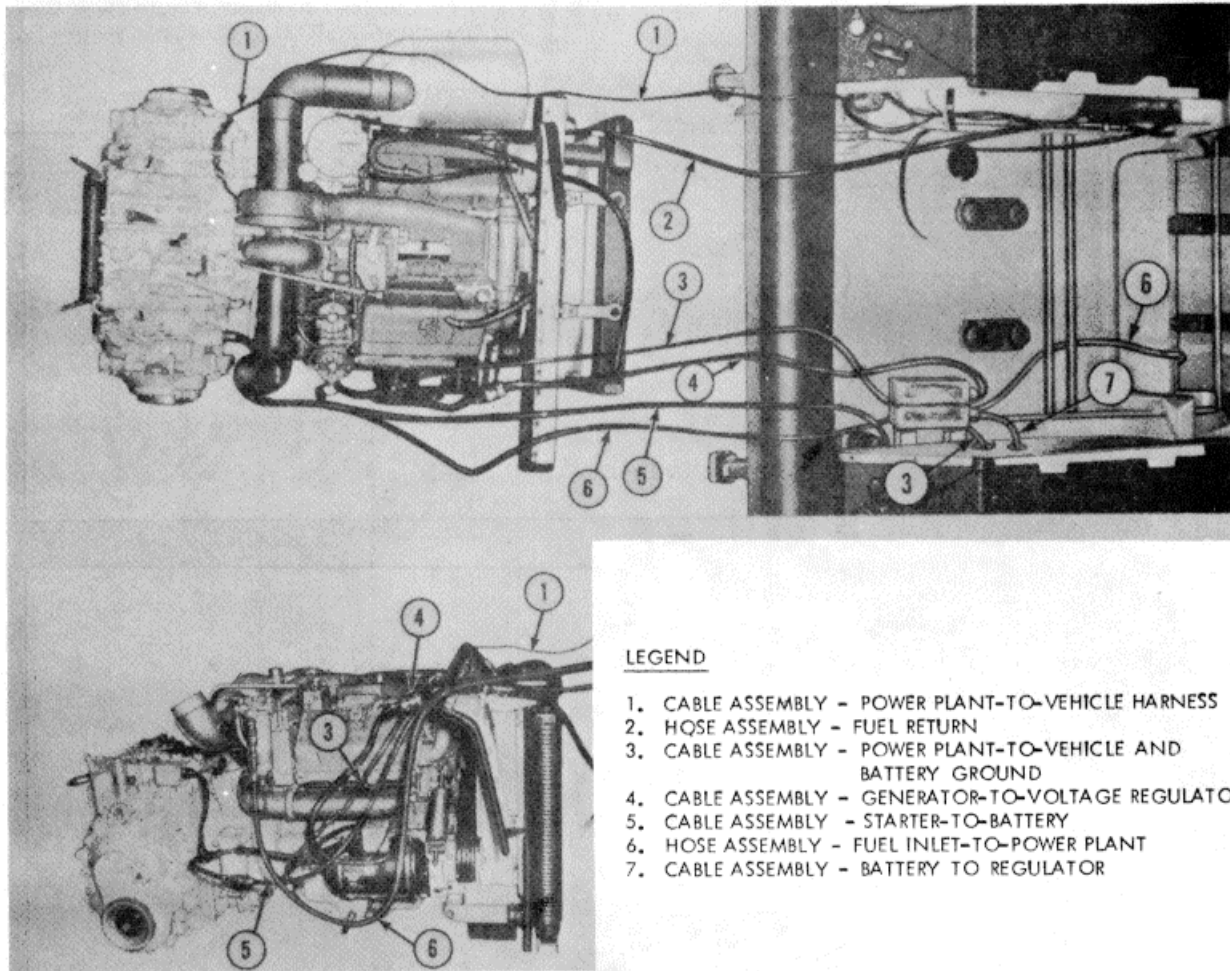

#### LEGEND

1. CABLE ASSEMBLY - POWER PLANT-TO-VEHICLE HARNESS
2. HOSE ASSEMBLY - FUEL RETURN
3. CABLE ASSEMBLY - POWER PLANT-TO-VEHICLE AND BATTERY GROUND
4. CABLE ASSEMBLY - GENERATOR-TO-VOLTAGE REGULATOR
5. CABLE ASSEMBLY - STARTER-TO-BATTERY
6. HOSE ASSEMBLY - FUEL INLET-TO-POWER PLANT
7. CABLE ASSEMBLY - BATTERY TO REGULATOR

#### PRELIMINARY STEPS

- A. REMOVE POWER PLANT FROM VEHICLE (FIGS. 9-3,4,5 AND 6) AND PLACE CLOSE TO REAR OF VEHICLE AS SHOWN ABOVE.
- B. CONNECT POWER PLANT AND VEHICLE ELECTRICAL AND FUEL SYSTEMS USING CABLE ASSEMBLIES AND FUEL HOSES LISTED IN TABLE 8-I. REFER TO FIG. 9-4 FOR LOCATION OF DISCONNECT POINTS ON VEHICLE.
- C. USE AIR CLEANER AND EXHAUST ELBOW TO PREVENT ENTRANCE OF DIRT OR OTHER FOREIGN MATTER INTO TURBOCHARGER.

#### PROCEDURE

1. POSITION ONE MAN TO RIGHT OF POWER PLANT TO OPERATE THROTTLE AND FUEL SHUT-OFF CONTROLS.
2. POSITION SECOND MAN IN DRIVER'S COMPARTMENT TO OPERATE STARTER AND OBSERVE PRESSURE AND TEMPERATURE GAGES. USE OF EXTERNAL PHONE WILL FACILITATE COMMUNICATIONS.
3. IF DESIRED, USE RADIATOR COVER TO EXPEDITE ENGINE WARM-UP TO OPERATING TEMPERATURE.
4. USE EXTREME CARE AROUND FAN AND BELTS WHILE ENGINE IS RUNNING.
5. WATCH CLOSELY TO PREVENT POWER PLANT FROM VIBRATING OFF BLOCKS.
6. OBSERVE AND CORRECT ANY MALFUNCTIONS AND LEAKS.
7. TIGHTEN ALL COOLANT HOSE CLAMPS WHILE ENGINE IS STILL WARM.
8. REMOVE TEST KIT ACCESSORIES AND INSTALL POWER PLANT IN VEHICLE.

TA007322

Figure 9-10. Test operation of power plant out of vehicle

**Section 9-2. ENGINE AND COMPONENTS**

**9-8. General**

procedures for engine and components shown in table 9-2, and paragraphs 9-9 and 9-10.

This section contains organizational maintenance

**TABLE 9-2. ENGINE AND COMPONENTS**

ASSEMBLY OR COMPONENT	FIGURE REFERENCE			
	SERVICE	ADJUST	REPLACE	REPAIR
Oil Filter, Element, and Cover Assembly	9-11		9-11	
Engine/Transmission Oil Cooler Cores			9-12	
Engine/Breather Drain Collector Hoses, Tubes, and Fittings			9-13	
Air Box Heater Components			9-14	
Air Box Heater Pump/Valve, Coil, and Accumulator	9-16		9-15	
Fuel Filters and Elements			9-17	
Engine Fuel System Hoses and Fittings (Refer to Para 9-9)			9-18	
Fuel Pump (Refer to Para 9-9)			9-19	
Fuel Tank Shut-off Valve			9-20	
Fuel Filler Cap and Filter			9-21	
Fuel Shut-off Control and Linkage		9-22	9-23	9-23
Engine Air Cleaner and Components	5-1		9-24	9-24
Filter and Air Cleaner			9-24.1	
Blower Assembly and Hose			9-24.2	
Hull Wiring Harness and Leads			9-24.3	
Engine Wiring Harness			9-24.4	
Exhaust Manifolds and Elbows			9-25	
Exhaust Muffler and Components			9-26	
Exhaust Crossover Pipe			9-27	
Engine Coolant System (refer to para 9-10)			9-28	
Radiator Shrouds and Seals			9-29	9-29
Coolant Radiator			9-30,	
			9-31	
Coolant Fan and Pulley			9-32	
Coolant Fan/Generator Drive Belts			9-109	
Coolant Fan Clutch Assembly			9-33	
Surge Tank			9-34	
Coolant Tubes, Hoses, and Fittings			9-35	
Coolant Pump			9-36	
Coolant Thermostat Housing and Thermostat			9-37	
Radiator Support			9-38	

**9-9. Engine Fuel System (Fig. 9-17)****a. Checking Fuel Flow.**

- (1) Open exhaust grille doors, disconnect fuel return hose at quick disconnect (Fig. 9-4), remove disconnect from hose and place end of hose in a one gallon container.
- (2) Start and run engine at 1200 rpm and measure the fuel flow return for a period of one minute. Approximately one-half gallon of fuel should flow from the return hose per minute.
- (3) Immerse end of fuel hose into fuel container. Air bubbles rising to the surface of the liquid will indicate a leak on the suction side of the pump. Check all hose connections and gaskets on strainer and filter elements.
- (4) If the fuel flow is insufficient for satisfactory engine performance, then check the strainer element and filter element and replace either or both if clogged. Start engine and run it at 1200 rpm to check fuel flow. If fuel flow is still unsatisfactory, replace fuel pump (fig. 9-19) and again check flow. When changing a fuel pump, clean pump lines with compressed air and be sure all fuel line connections are tight.
- (5) Connect fuel return hose to quick disconnect.

**b. Checking Fuel Pump.** If the fuel pump fails to function properly, check for broken pump shaft or dirt in relief valve before removing the pump from the engine:

- (1) Insert end of a wire through one of the pump body drain holes, then crank engine momentarily and see if wire vibrates. Vibration will be felt if pump shaft rotates.
- (2) Without removing pump from engine, unscrew valve plug; and remove gasket, spring, pin, and valve. Wash parts with solvent and blow out valve cavity with compressed air. Install valve parts and check flow.

**9-10. Engine Coolant System (Fig. 9-28)**

**a.** When coolant system has been drained to service coolant components, the system should be flushed to remove scale deposited by hard, mineral-laden water.

- (1) Drain system (table 5-4).
- (2) Refill system with clean soft water. If engine is hot, fill slowly to prevent distortion of engine castings.
- (3) Start engine and operate for 15 minutes.
- (4) Drain coolant system completely (table 5-4).
- (5) Refill cooling system according to Table 9-2.1.

**b.** Whenever hose connections have been disturbed or when coolant system has been drained, retorque clamps to 40-60 pounds-inches after engine has been operated to normal operating temperature.

**TABLE 9-2.1. COOLANT MIXTURE**

<b>AMBIENT TEMPERATURE</b>	<b>ANTIFREEZE</b>	<b>INHIBITOR</b>	<b>PROPORTION</b>
-65°F to -40°F	6850-174-1806 6850-243-1992	----- -----	Full strength
-40°F to +80°F	or 6850-224-8730	----- -----	50-50
Above 80°F	-----	6850-753-4967	22-1/2 oz.

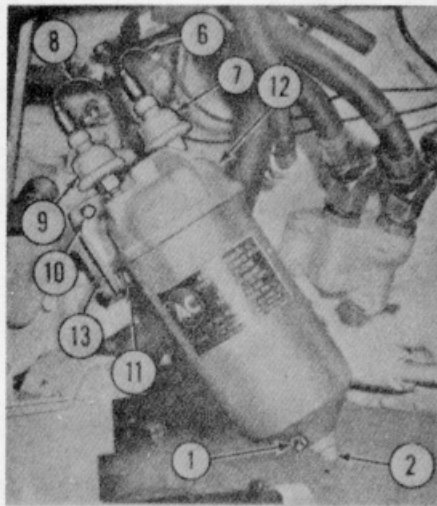

REMOVAL - OIL FILTER ASSY.

REMOVE ACCESS PLUG ON BOTTOM OF HULL (FIG. 5-7 ITEM 3)

- 1. DRAIN PLUG
- 2. CENTER STUD
- 3. OIL FILTER ASSEMBLY
- 4. FILTER GASKET
- 5. FILTER ELEMENT

REMOVAL - COVER ASSEMBLY

REMOVE AIR CLEANER (FIG. 9-24)

- 6. ELECTRICAL LEAD NO. 313
- 7. OIL PRESSURE SWITCH
- 8. ELECTRICAL LEAD NO. 50
- 9. BLOWER MOTOR PRESSURE SWITCH
- 10. SCREW (4)
- 11. FLAT WASHER (4) LOCK WASHER (4)
- 12. COVER
- 13. COVER GASKET

INSTALLATION NOTE.

TO INSTALL FILTER ASSEMBLY (3) REMOVE AIR CLEANER (FIG. 9-24) AND HOLD FILTER IN POSITION WHILE SECOND MECHANIC TIGHTENS STUD (2) THROUGH HULL ACCESS PLUG OPENING.

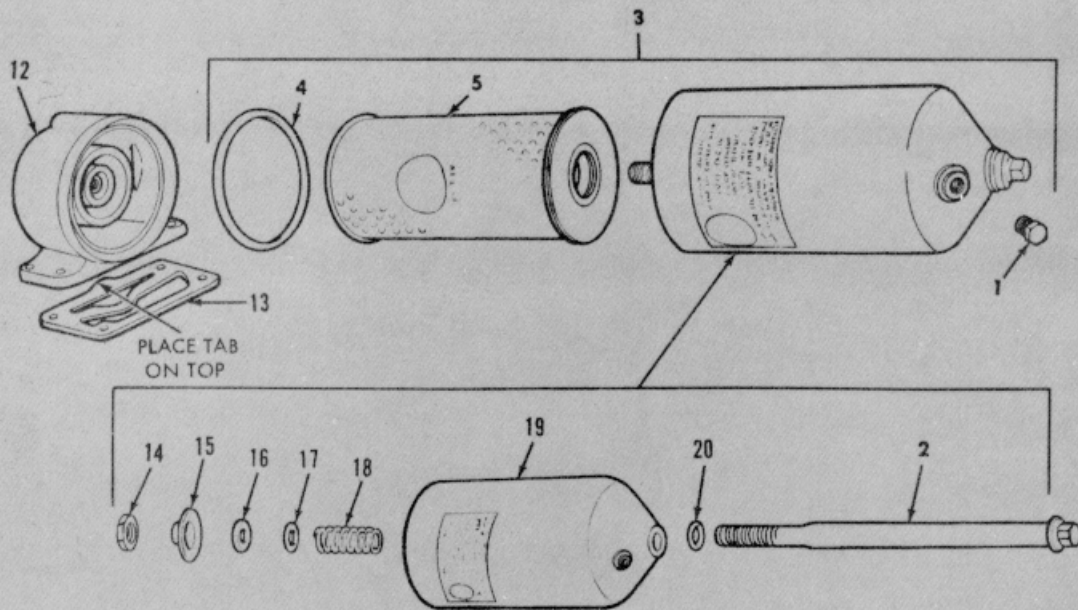

DISASSEMBLY

- 14. NUT
- 15. RETAINER
- 16. GASKET
- 17. WASHER
- 18. SPRING
- 19. SHELL
- 20. EXTERNAL GASKET

SERVICE

REPLACE UNSERVICEABLE PARTS AS REQUIRED.  
 REPLACE ALL GASKETS DISASSEMBLED.  
 FLUSH AND CLEAN SHELL AND INSTALL NEW FILTER AND FILTER GASKET.

ASSEMBLY/INSTALLATION

REVERSE DISASSEMBLY AND REMOVAL PROCEDURE.

TA007323

Figure 9-11. Removal/installation - engine oil filter, element, and adapter.

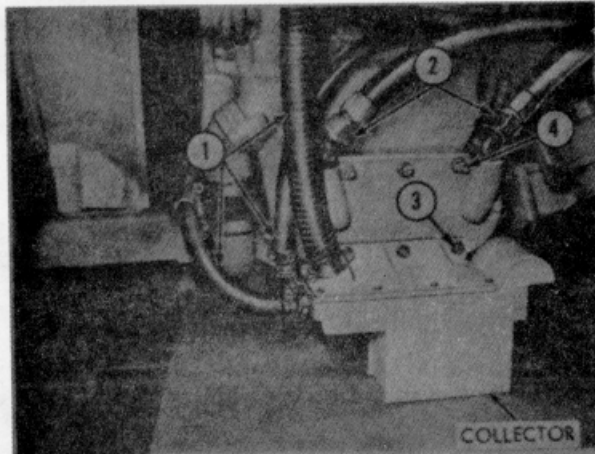

4. THREE NUTS, LOCK WASHERS, AND FLAT WASHERS.
5. HOUSING COVER, OUTER GASKET, TRANSMISSION OIL COOLER CORE, AND INNER GASKET.

INSTALLATION NOTE. CLEAN MATING FACES ON HOUSING, CORE, AND COVER, USE NEW GASKETS.

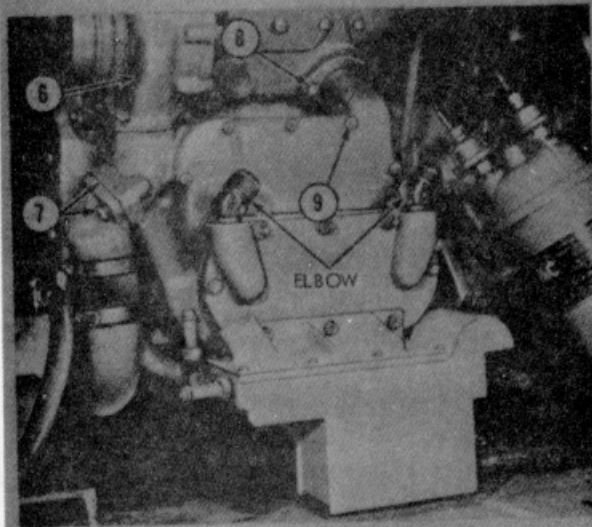

**REMOVAL - ENGINE OIL COOLER CORE**

NOTE. ENGINE OIL COOLER CORE MAY BE REMOVED WITHOUT REMOVING TRANSMISSION CORE FROM HOUSING. FOLLOW STEPS 1, 2, 4, 6 THROUGH 10.

6. COOLANT PUMP (FIGURE 9-36).
7. TWO SCREWS, LOCK WASHER, FLAT WASHERS, AND GASKET.

**INSTALLATION**

REVERSE REMOVAL SEQUENCE.

**PRELIMINARY STEPS**

- A. REMOVE POWER PLANT (FIGURES 9-3 THROUGH 9-5).
- B. DRAIN ENGINE COOLANT SYSTEM (TABLE 5-4) AND OIL COOLER HOUSING (PETCOCK UNDER COOLER HOUSING).

**REMOVAL - TRANSMISSION OIL COOLER CORE**

1. ENGINE BREATHER HOSE AND AIR BOX DRAIN HOSE (2).
2. TRANSMISSION OIL COOLER INLET AND OUTLET HOSE NUTS.
3. FIVE SCREWS, LOCK WASHERS, FLAT WASHERS, AND AIR BOX ENGINE BREATHER DRAIN COLLECTOR.

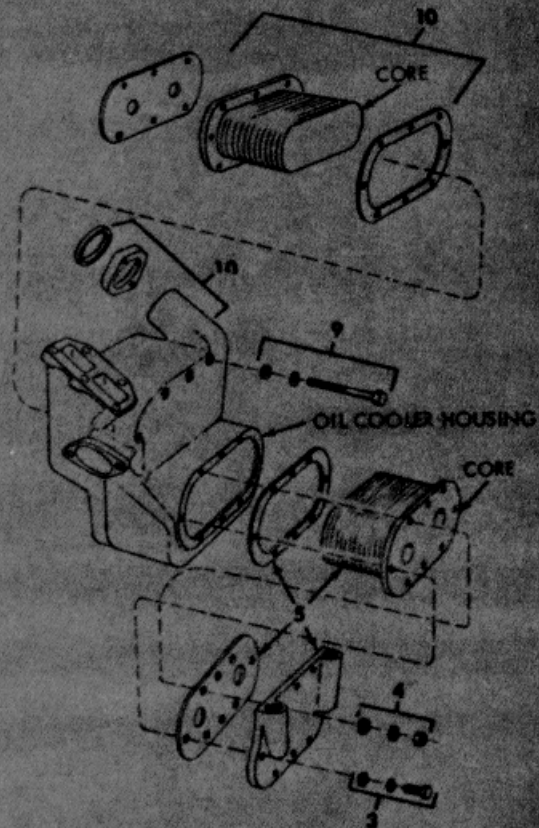

8. TWO SCREWS, LOCK WASHERS, AND FLAT WASHERS.
9. FIVE SCREWS, LOCK WASHERS, AND FLAT WASHERS.
10. OIL COOLER HOUSING, INNER GASKET, CORE, OUTER GASKET, WATER OUTLET FLANGE, AND FLANGE SEAL.

INSTALLATION NOTE. CLEAN MATING FACES ON HOUSING, CORE, AND ENGINE BLOCK, USE NEW GASKETS AND SEAL.

TA007324

Figure 9-12. Removal/installation - engine/transmission oil cooler cores



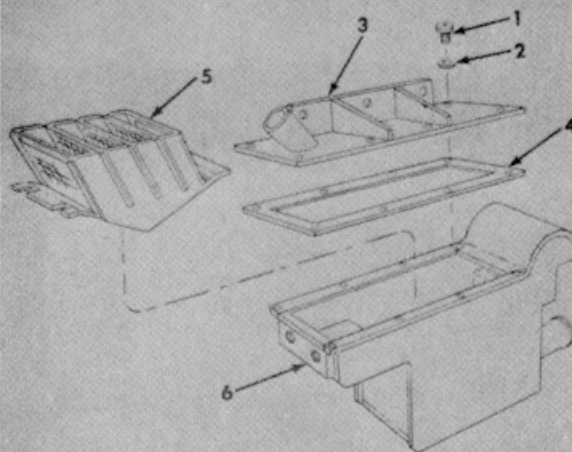
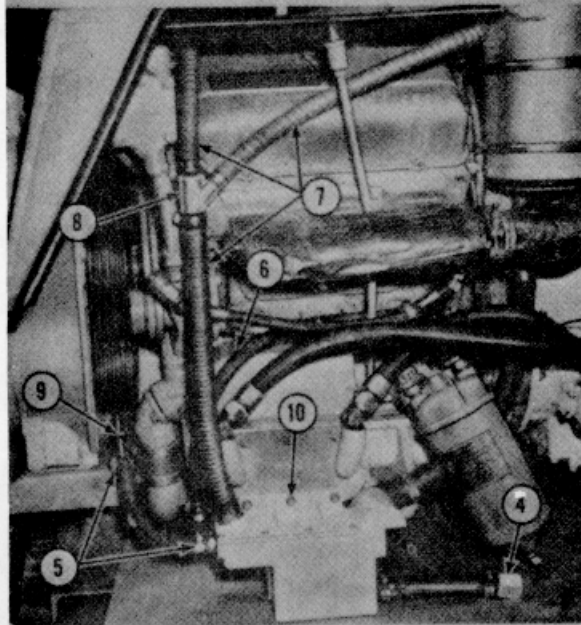
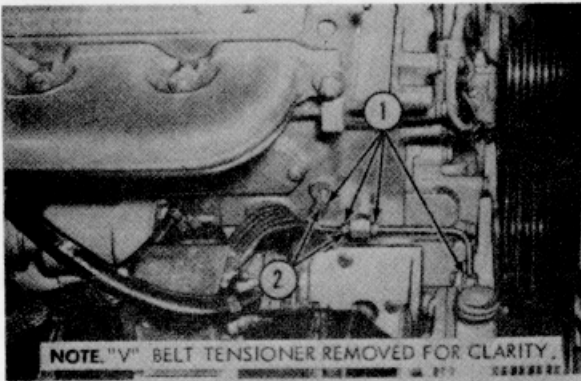

#### PRELIMINARY STEPS

REMOVE POWER PLANT (FIGURE 9-3 THROUGH 9-6).

#### REMOVAL

1. LOOSEN 4 NUTS AND REMOVE 2 RIGHT SIDE AIR BOX DRAIN TUBES.
2. REMOVE STREET ELBOW AND TEE FITTING ATTACHED TO CYLINDER BLOCK (IF NECESSARY TO CLEAN OR REPLACE).
3. LOOSEN LOWER HOSE CLAMP (AT END OF CROSSOVER TUBE (9)) AND REMOVE HOSE FROM CROSSOVER TUBE.
4. REMOVE PLUG, AND DRAIN COLLECTOR.
5. LOOSEN HOSE CLAMPS (2) AND REMOVE HOSE.
6. LOOSEN HOSE CLAMPS (2) AND REMOVE HOSE AND FITTINGS.
7. LOOSEN 6 HOSE CLAMPS AND REMOVE 2 BREATHER HOSES FROM LEFT AND RIGHT VALVE ROCKER COVERS TO "Y" AND HOSE FROM "Y" TO DRAIN COLLECTOR.
8. REMOVE SCREW, WASHER, BRACKET AND "Y" FITTING.
9. REMOVE SCREWS (2), WASHERS (2), CLAMPS (2), AND CROSSOVER TUBE.
10. REMOVE THREE SCREWS, LOCKWASHERS, WASHERS, AND DRAIN COLLECTOR.

#### INSTALLATION

REVERSE REMOVAL PROCEDURE.

#### REMOVAL - DRAIN COLLECTOR BAFFLE

- |               |           |
|---------------|-----------|
| 1. SCREW (8)  | 4. GASKET |
| 2. WASHER (8) | 5. BAFFLE |
| 3. COVER      | 6. BOX    |

#### SERVICE

REMOVE RESIDUE FROM BAFFLE AND BOX WITH DRY CLEANING SOLVENT OR MINERAL SPIRITS AND DRY WITH LOW PRESSURE COMPRESSED AIR.

#### INSTALLATION

CLEAN MATING SURFACES OF COVER AND BOX. USE NEW COVER GASKET. REVERSE REMOVAL PROCEDURE AND TIGHTEN SCREWS (1) SECURELY.

1A007325

Figure 9-13. Removal/installation/service - engine breather drain collector hoses,

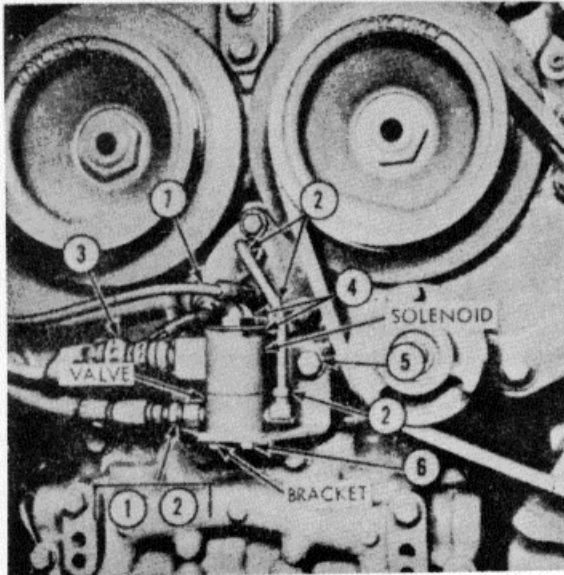

A. SOLENOID VALVE, AND BRACKET

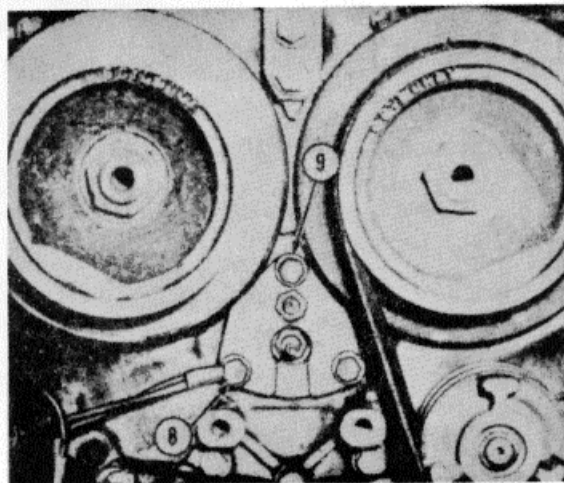

B. AIR BOX HEATER

PRELIMINARY STEPS

- A. REMOVE POWER PLANT (FIG. 9-3 THROUGH 9-6).
- B. REMOVE RADIATOR (FIG. 9-30).
- C. REMOVE FAN SHROUD (FIG. 9-29).
- D. REMOVE FAN AND FAN PULLEY (FIG. 9-32).

**CAUTION:** FUEL LINE IS UNDER 60-65 POUNDS-PRESSURE.

- 1. LOOSEN FUEL LINE NUT AND DRAIN FUEL FROM ACCUMULATOR AND HOSE INTO A SUITABLE CONTAINER.
- 2. FUEL LINE NUTS (3), FUEL TUBE, AND HOSE.
- 3. ELECTRICAL CIRCUIT LEAD.
- 4. SOLENOID NUT AND PLATE. SEPARATE SOLENOID AND VALVE.
- 5. TWO SCREWS, LOCK WASHERS, FLAT WASHERS, AND BRACKET WITH VALVE.
- 6. TWO SCREWS, WASHERS AND REMOVE VALVE FROM BRACKET.
- 7. ELECTRODE ELECTRICAL LEAD.

REMOVAL - AIR BOX HEATER

- 8. THREE SCREWS, WASHERS, AND GROUND WIRE.
- 9. AIR BOX HEATER AND GASKET.

INSTALLATION NOTE: CLEAN SURFACES  
APPLY SEALANT 8030-236-6436.

INSTALLATION

REVERSE REMOVAL PROCEDURE.

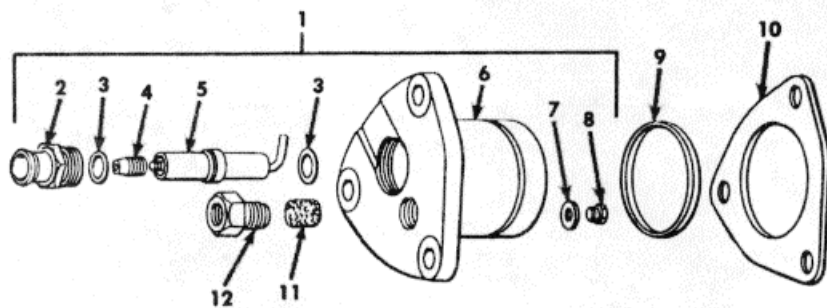

LEGEND

- 1. HEATER ASSEMBLY
- 2. ELECTRODE NUT
- 3. COPPER WASHER
- 4. TERMINAL NUT
- 5. ELECTRODE
- 6. HOUSING
- 7. COPPER WASHER
- 8. SPRAY NOZZLE
- 9. PACKING
- 10. GASKET
- 11. INJECTOR FILTER
- 12. FILTER CAP

REPLACE UNSERVICEABLE COMPONENTS

WE 11075A

Figure 9-14. (Superseded) Removal/installation/repair - air box heater components



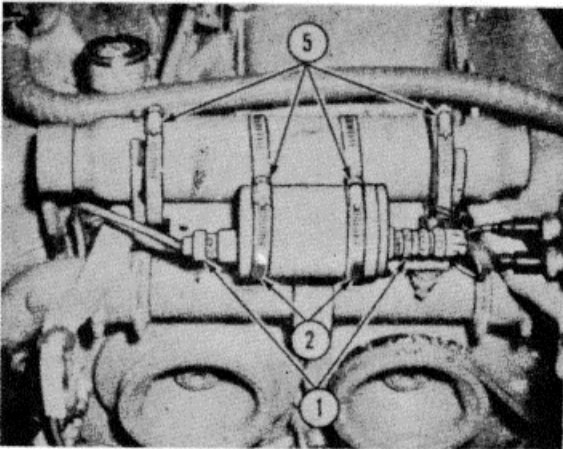

#### PRELIMINARY STEP

RELIEVE FUEL PRESSURE IN ACCUMULATOR (STEP 1, FIG. 9-14).

#### REMOVAL

##### COIL AND ACCUMULATOR

1. DISCONNECT ELECTRICAL CIRCUIT LEADS (2).
2. LOOSEN CLAMPS (2) AND SLIDE COIL FROM BRACKET.
3. DISCONNECT FUEL LINE NUTS (2).
4. LOOSEN CLAMPS AND ROTATE ACCUMULATOR TO PLACE PRESSURE GAGE AND ADAPTER AT TOP OF ACCUMULATOR. REMOVE GAGE AND ADAPTER.
5. REMOVE ACCUMULATOR, SPLIT HOSE (4) AND CLAMPS (4).

##### PUMP ASSEMBLY

6. DISCONNECT FUEL LINE NUTS (2).
7. LOOSEN LOCK NUT.
8. REMOVE PUMP BODY.

#### INSTALLATION

REVERSE REMOVAL SEQUENCE. INSTALL PUMP IN BRACKET TO POSITION PUMP HANDLE A MAXIMUM OF 2-1/4 INCHES OVER BRACKET. RECHARGE ACCUMULATOR WITH FUEL (TABLE 2-4.1).

#### OPERATIONAL CHECK PROCEDURE

- A. START ENGINE AND WARM TO OPERATING TEMPERATURE.
- B. IDLE ENGINE 700-800 RPM.
- C. OPERATE "FLAME HEAT" SWITCH ON DRIVER'S SWITCH PANEL. ENGINE SPEED WILL DECREASE TO APPROX. 600 RPM.
- D. RECHARGE ACCUMULATOR WITH FUEL AFTER USE (TABLE 2-4.1).

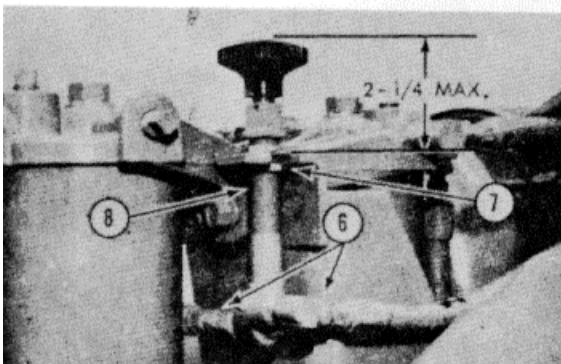
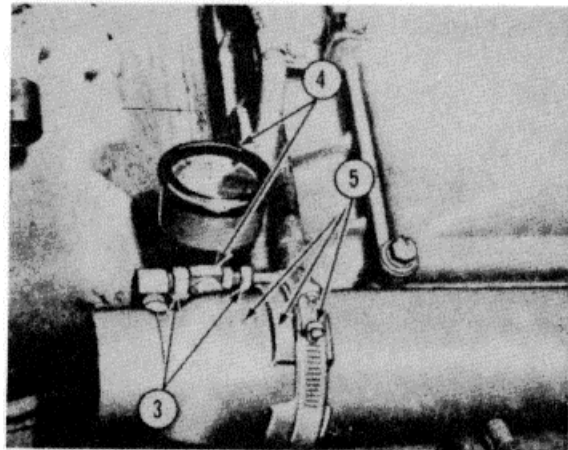
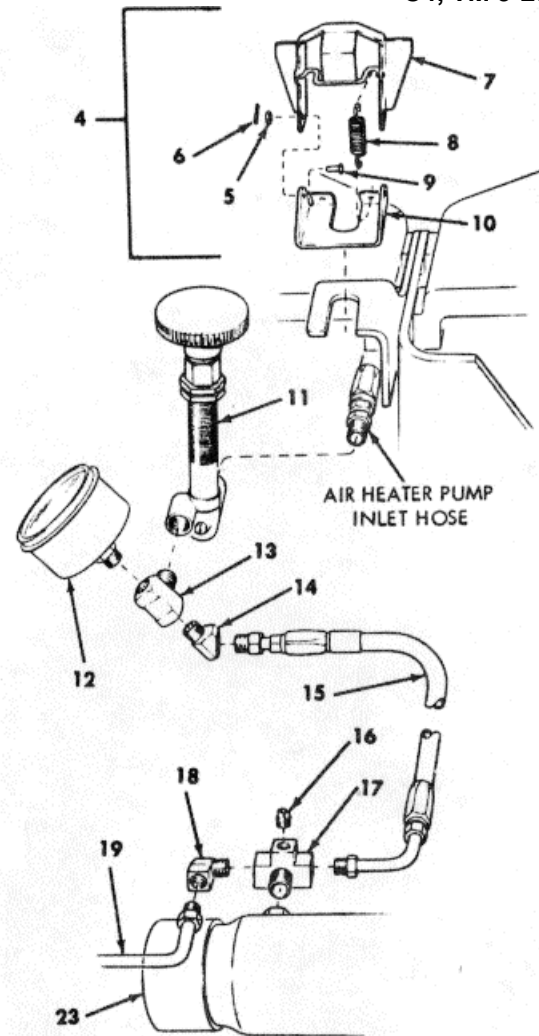
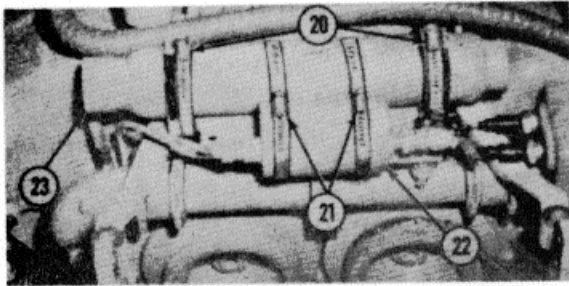
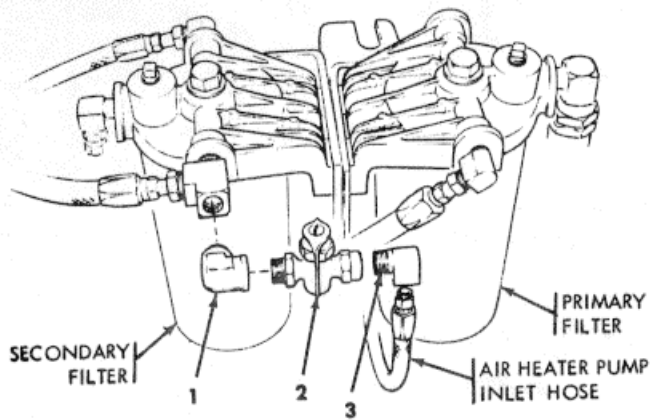

Figure 9-15. (Superseded) Removal/installation - air box heater accumulator, coil, and pump

WE 112428

**LEGEND**

1. ELBOW - 72582-190367
2. SHUTOFF VALVE - 72582-5143326
3. ELBOW - 72582-143343
4. PUMP LOCK ASSEMBLY - 11619315
5. WASHER (2)
6. COTTER PIN (2)
7. UPPER LOCK BRACKET
8. SPRING (2)
9. PIN (2)
10. LOWER LOCK BRACKET
11. PUMP ASSEMBLY
12. PRESSURE GAGE
13. TEE - 72582-178996
14. ELBOW - 72582-116341
15. PUMP-TO-ACCUMULATOR HOSE
16. PLUG - 72582-113175
17. TEE
18. ELBOW
19. ACCUMULATOR-TO-VALVE HOSE
20. CLAMP (2)
21. CLAMP (2)
22. COIL
23. ACCUMULATOR

**REMOVAL/INSTALLATION**

REPLACE UNSERVICEABLE COMPONENTS AS REQUIRED.

NOTE. ENGINES WITH SERIAL NUMBERS PREVIOUS TO 6D-33513 MAY BE EQUIPPED WITH PUMP LOCK ASSEMBLY, SHUTOFF VALVE, AND RELOCATED PRESSURE GAGE BY REQUISITIONING ITEMS 1, 2, 3, 4, 13, 14, AND 16 BY PART NUMBER INDICATED IN LEGEND.

WE 11927

Figure 9-15.1. (Added) Removal/installation - air box heater accumulator, coil, and pump (effective vehicle serial no. 62)

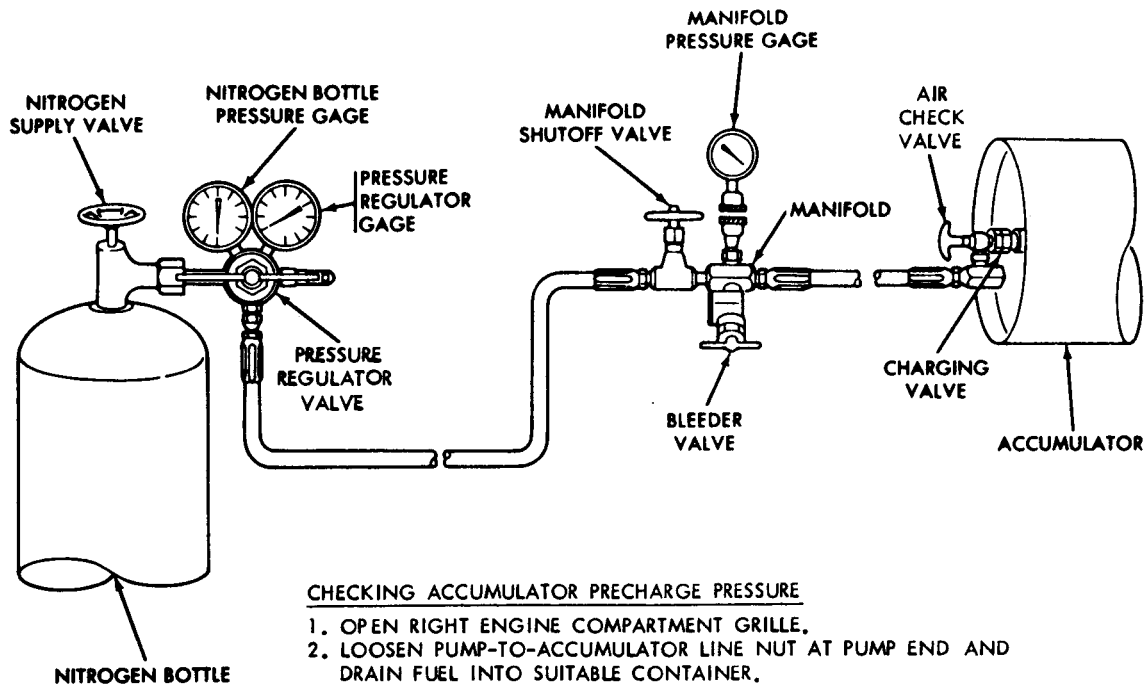

#### CHECKING ACCUMULATOR PRECHARGE PRESSURE

1. OPEN RIGHT ENGINE COMPARTMENT GRILLE.
2. LOOSEN PUMP-TO-ACCUMULATOR LINE NUT AT PUMP END AND DRAIN FUEL INTO SUITABLE CONTAINER.  
CAUTION: FUEL PRESSURE IN A FULLY CHARGED ACCUMULATOR IS 55-65 PSI.
3. REMOVE VALVE CAP ON END OF ACCUMULATOR.
4. CHECK NITROGEN PRESSURE WITH A TIRE GAGE. PRESSURE SHOULD BE 25-40 PSI.

#### CHARGING ACCUMULATOR WITH NITROGEN

1. DRAIN FUEL FROM ACCUMULATOR, STEPS 1 AND 2 ABOVE.
2. ATTACH REGULATOR KIT - 4910-766-3354 TO NITROGEN BOTTLE.  
**WARNING:** BOTTLE MUST CONTAIN NITROGEN. OTHER GASES WILL CAUSE ACCUMULATOR TO EXPLODE.
3. CLOSE PRESSURE REGULATOR VALVE BY TURNING T-HANDLE COUNTERCLOCKWISE UNTIL IT TURNS FREELY.
4. TURN NITROGEN SUPPLY VALVE COUNTERCLOCKWISE UNTIL FULLY OPEN. NITROGEN BOTTLE PRESSURE GAGE MUST INDICATE A MINIMUM OF 40 PSI. IF NOT, REPLACE WITH FULLY CHARGED BOTTLE.
5. OPEN MANIFOLD SHUTOFF VALVE, AND CLOSE BLEEDER VALVE.
6. PURGE LINES BY SLOWLY TURNING PRESSURE REGULATOR VALVE HANDLE CLOCKWISE UNTIL GAS IS HEARD ESCAPING FROM AIR CHECK VALVE. AFTER 5 TO 10 SECONDS, CLOSE MANIFOLD SHUTOFF VALVE.
7. REMOVE CAP FROM ACCUMULATOR CHARGING VALVE, AND INSTALL AIR CHECK VALVE AS FOLLOWS:
  - (a) TURN T-HANDLE COUNTERCLOCKWISE ALL THE WAY OUT
  - (b) THREAD AIR CHECK VALVE TIGHTLY ONTO CHARGING VALVE.
  - (c) TURN T-HANDLE CLOCKWISE ALL THE WAY IN.
8. SLOWLY OPEN PRESSURE REGULATOR VALVE UNTIL PRESSURE REGULATOR GAGE INDICATES 35 PSI.
9. SLOWLY OPEN MANIFOLD SHUTOFF VALVE.  
**NOTE.** IF ACCUMULATOR GAGE SHOWS BUILDUP OF PRESSURE, REPEAT STEP (1) ABOVE. IF GAGE CONTINUES TO SHOW PRESSURE AFTER STEP (1) HAS BEEN REPEATED, LOOSEN FUEL LINE NUT AT GAGE AND REPEAT STEPS (7) AND (8). ESCAPING GAS (NITROGEN) WILL SHOW THAT ACCUMULATOR IS DEFECTIVE. REPLACE ACCUMULATOR.
10. CLOSE NITROGEN SUPPLY VALVE WHEN PRESSURE REGULATOR GAGE STABILIZES AT 35 PSI.  
**NOTE.** SHOULD OVERCHARGING OCCUR, CLOSE NITROGEN SUPPLY VALVE, AND BLEED OFF EXCESS PRESSURE WITH BLEEDER VALVE.
11. TURN T-HANDLE OF AIR CHECK VALVE ALL THE WAY OUT. OPEN BLEEDER VALVE.
12. REMOVE CHARGING EQUIPMENT. REPLACE CHARGING VALVE CAP.
13. ACTIVATE ACCUMULATOR HAND PUMP SEVERAL TIMES AND OBSERVE READING ON GAGE (FIG. 2-14). PRESSURE GAGE SHOULD SHOW RAPID PRESSURE RISE FROM ZERO TO PRECHARGE PRESSURE, WHERE IT WILL REMAIN WITHOUT NOTICEABLE CHANGE FOR SEVERAL ADDITIONAL STROKES OF PUMP ASSEMBLY.
14. CHECK ACCUMULATOR AND HOSE CONNECTIONS FOR FUEL AND NITROGEN LEAKS. WE11219

Figure 9-16. (Superseded) Testing and recharging air box heater accumulator nitrogen pressure

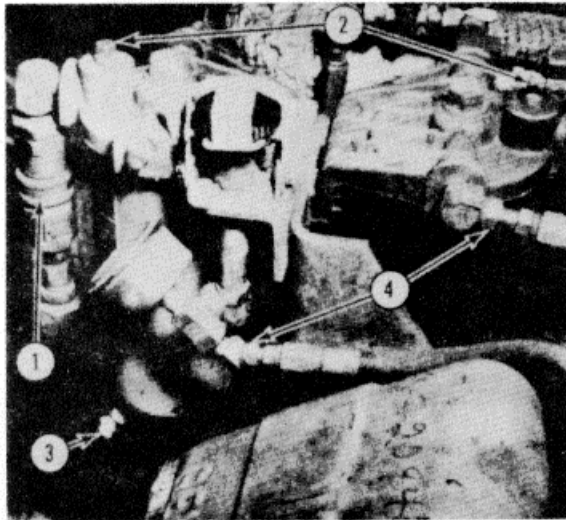

**PRELIMINARY STEP**

OPEN RIGHT ENGINE COMPARTMENT GRILLE DOOR.  
**REMOVAL**

1. MAIN FUEL LINE AND FUEL RETURN LINE QUICK DISCONNECT COUPLINGS
2. FILLER PLUGS (2)

INSTALLATION NOTE. FILL BOTH FILTERS WITH CLEAN FUEL.

3. DRAIN PRIMARY AND SECONDARY FILTERS
4. NUTS (2) AND FUEL LINES
5. NUTS (4) AND FUEL LINES
6. BOLT, WASHER, AND PRIMARY FILTER ASSEMBLY
7. BOLT, WASHER, AND SECONDARY FILTER ASSEMBLY
8. TWO NUTS, WASHERS, SCREWS, COVERS, AND ACCUMULATOR FUEL PUMP BRACKET WITH PUMP FUEL LINE AND GAGE

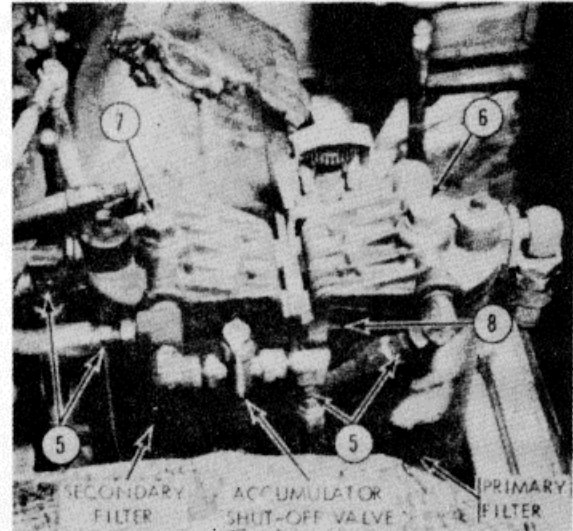

NOTE. EARLY VEHICLES ARE NOT EQUIPPED WITH ACCUMULATOR SHUT-OFF VALVE AND GAGE WAS MOUNTED AT ACCUMULATOR. REFER TO FIGURES 9-15 AND 9-15.1.

**INSTALLATION**

REVERSE REMOVAL PROCEDURE.

NOTE. FILTER ELEMENTS MAY BE SERVICED WITHOUT REMOVING COVERS AND FUEL LINES FROM FILTERS. FOLLOW STEPS 1, 2, 3, 6, AND 7 ABOVE. CLEAN SHELL BEFORE INSTALLING NEW ELEMENTS AND GASKETS.

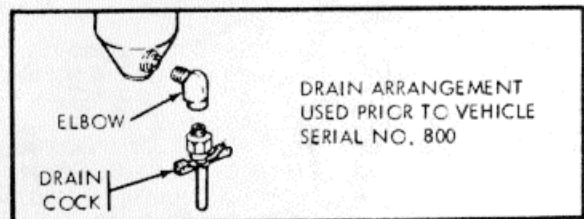
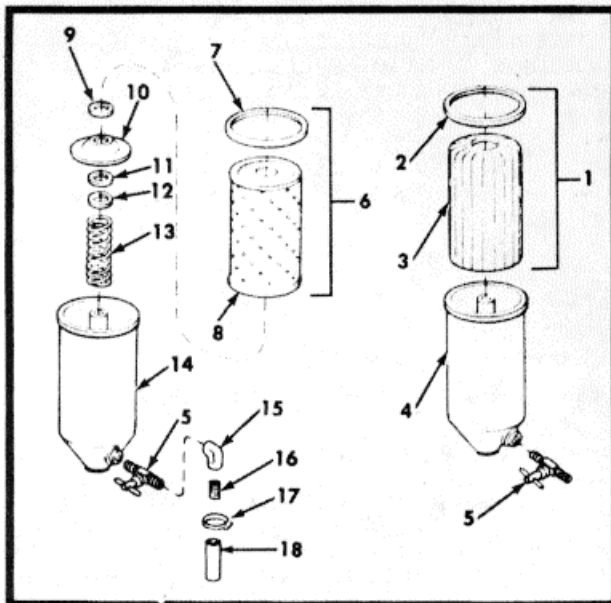

DRAIN ARRANGEMENT USED PRIOR TO VEHICLE SERIAL NO. 800

**LEGEND**

1. PRIMARY FILTER KIT
2. PRIMARY FILTER GASKET
3. PRIMARY FILTER ELEMENT
4. PRIMARY FILTER SHELL
5. DRAIN VALVE
6. SECONDARY FILTER KIT
7. SECONDARY FILTER GASKET
8. SECONDARY FILTER ELEMENT
9. RETAINER
10. ELEMENT SEAT
11. SPRING UPPER SEAT
12. SPRING LOWER SEAT
13. ELEMENT SPRING
14. SECONDARY FILTER SHELL
15. ELBOW
16. ADAPTER
17. CLAMP
18. HOSE

WE 11268A

Figure 9-17. (Superseded) Removal/installation - engine fuel filters and elements

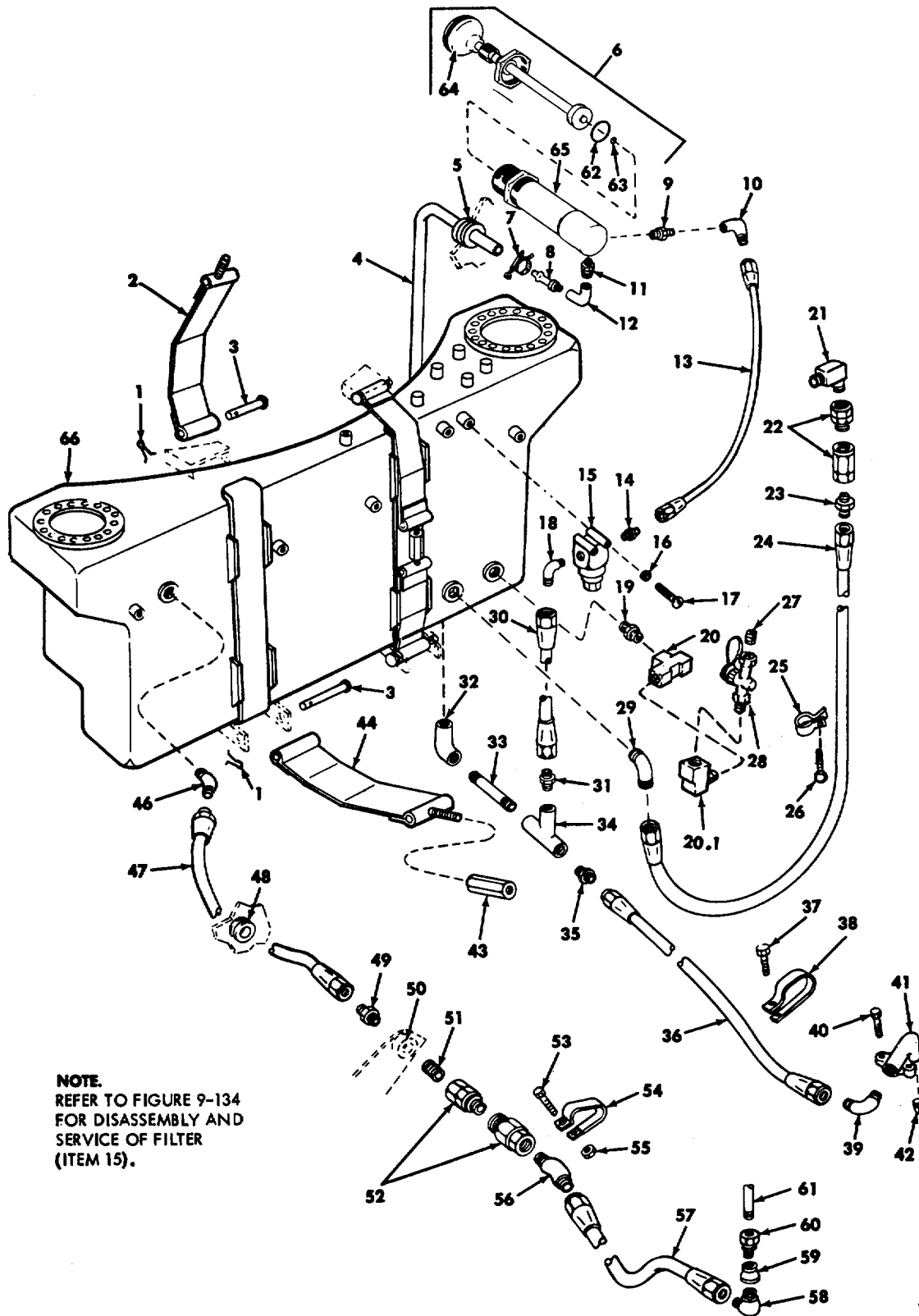

WE 11288A

Figure 9-18. (Superseded) Removal/installation/repair - engine fuel system hoses and fittings

TABLE 9-3. ENGINE FUEL SYSTEM HOSES AND FITTING, FIGURE 9-18

**PRELIMINARY STEPS**

- a. Remove power plant (figure 9-3 through 9-6).
- b. Drain fuel tanks (table 5-4).

**REMOVAL/INSTALLATION/REPAIR** - Replace unserviceable components as required.

ITEM NO.	COMPONENT	ITEM NO.	COMPONENT	ITEM NO.	COMPONENT	ITEM NO.	COMPONENT
1	Pin (4)	18	35	Nipple	51	Nipple	
2	Strap (2)	19	Nipple	36	Hose	52	Quick disconnect
3	Clevis pin (4)	20	T Connector	37	Screw	53	Screw
4	Drain hose	20.1	Elbow	38	Clamp	54	Clamp
5	Grommet	21	Elbow	39	Elbow	55	Nut
6	Pump, drain	22	Split coupling	40	Screw	56	Elbow
7	Clamp	23	Nipple	41	Fuel drain bracket	57	Hose
8	Nipple	24	Hose	42	Drain plug	58	Elbow
9	Check valve	25	Clamp	43	Turn buckle (2)	59	Reducer
10	Elbow	26	Screw	44	strap (2)	60	Nipple
11	Check valve	27	Plug	45	Pad (2)	61	Nipple
12	Elbow	28	Valve	46	Elbow	62	Packing
13	Hose	47	Hose	47	Hose	63	Packing
14	Nipple	30	Hose	48	Grommet	64	Plunger assy.
15	Filter	31	Nipple	49	Adapter	65	Pump body
16	Washer	32	Elbow	50	Quick disconnect	66	Fuel tank
17	Screw	33	Nipple		mount bracket		
		34	T Connector				

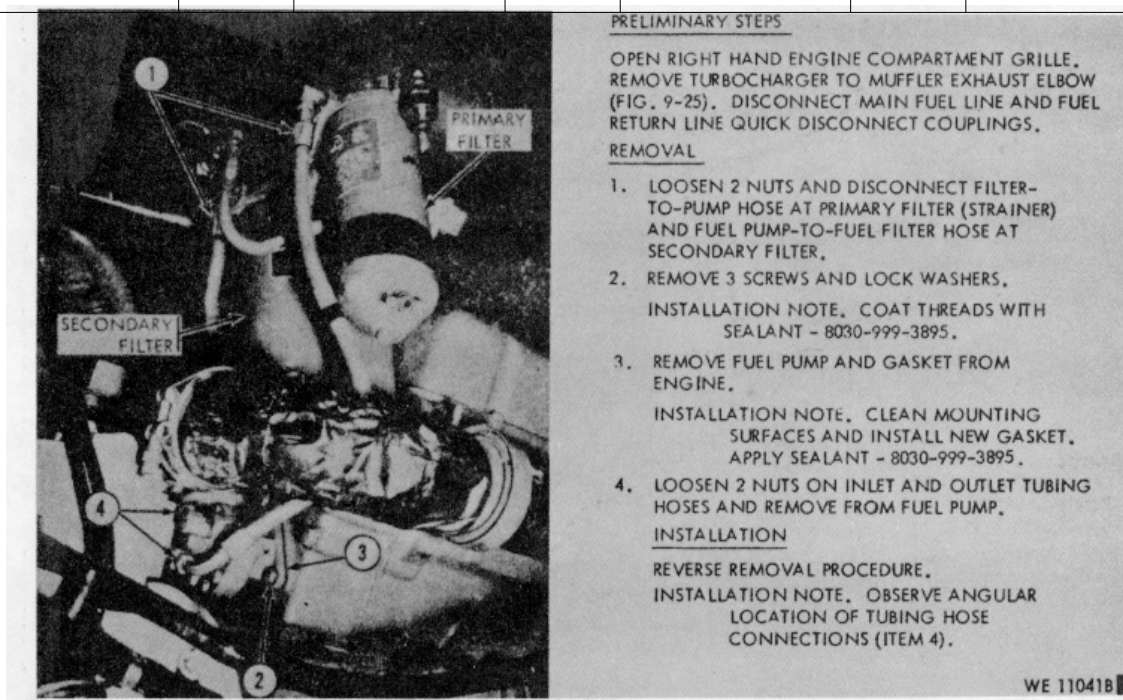

Figure 9-19. (Superseded) Removal/installation - engine fuel pump



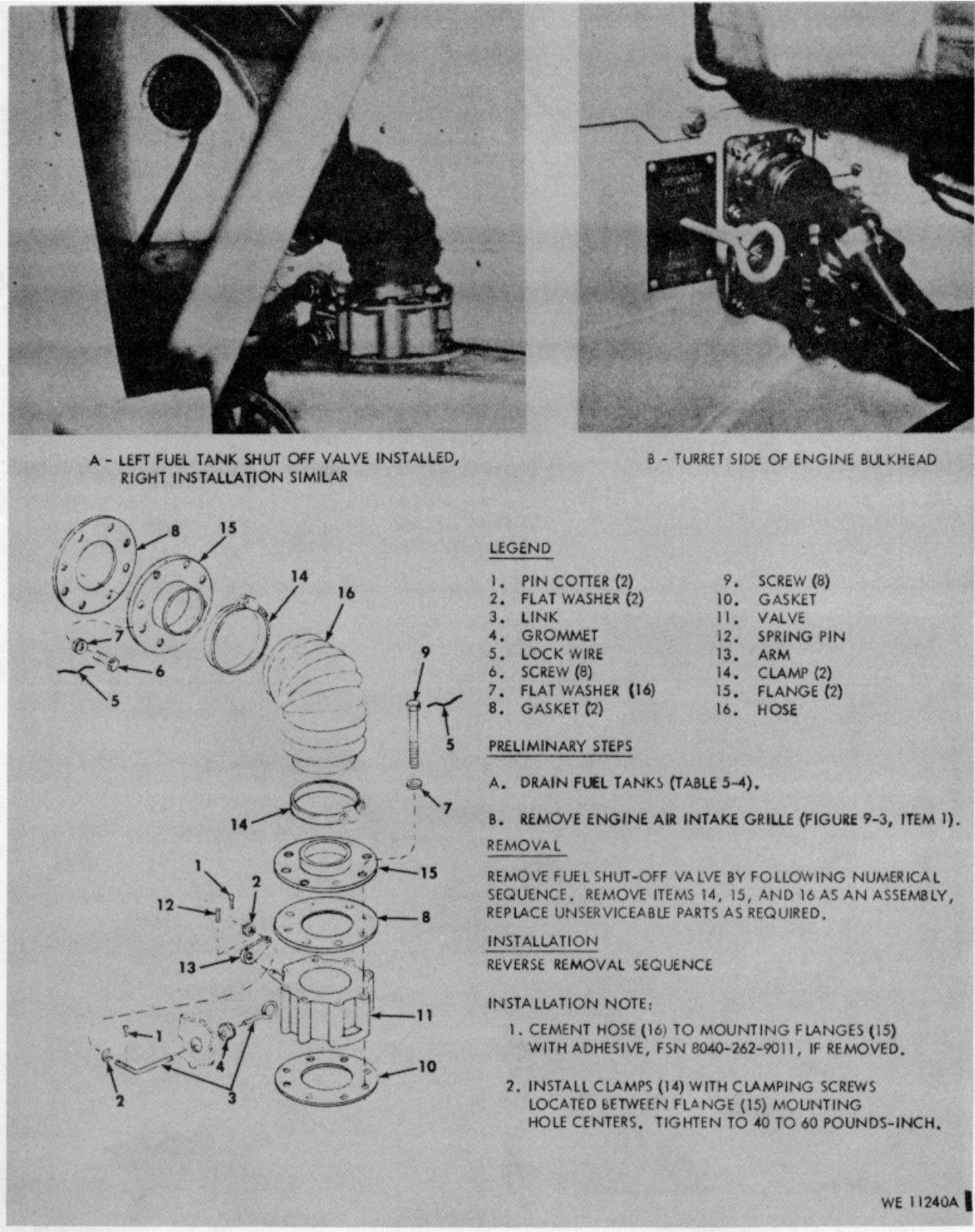

Figure 9-20. (Superseded) Removal/installation - fuel tank shut-off valves

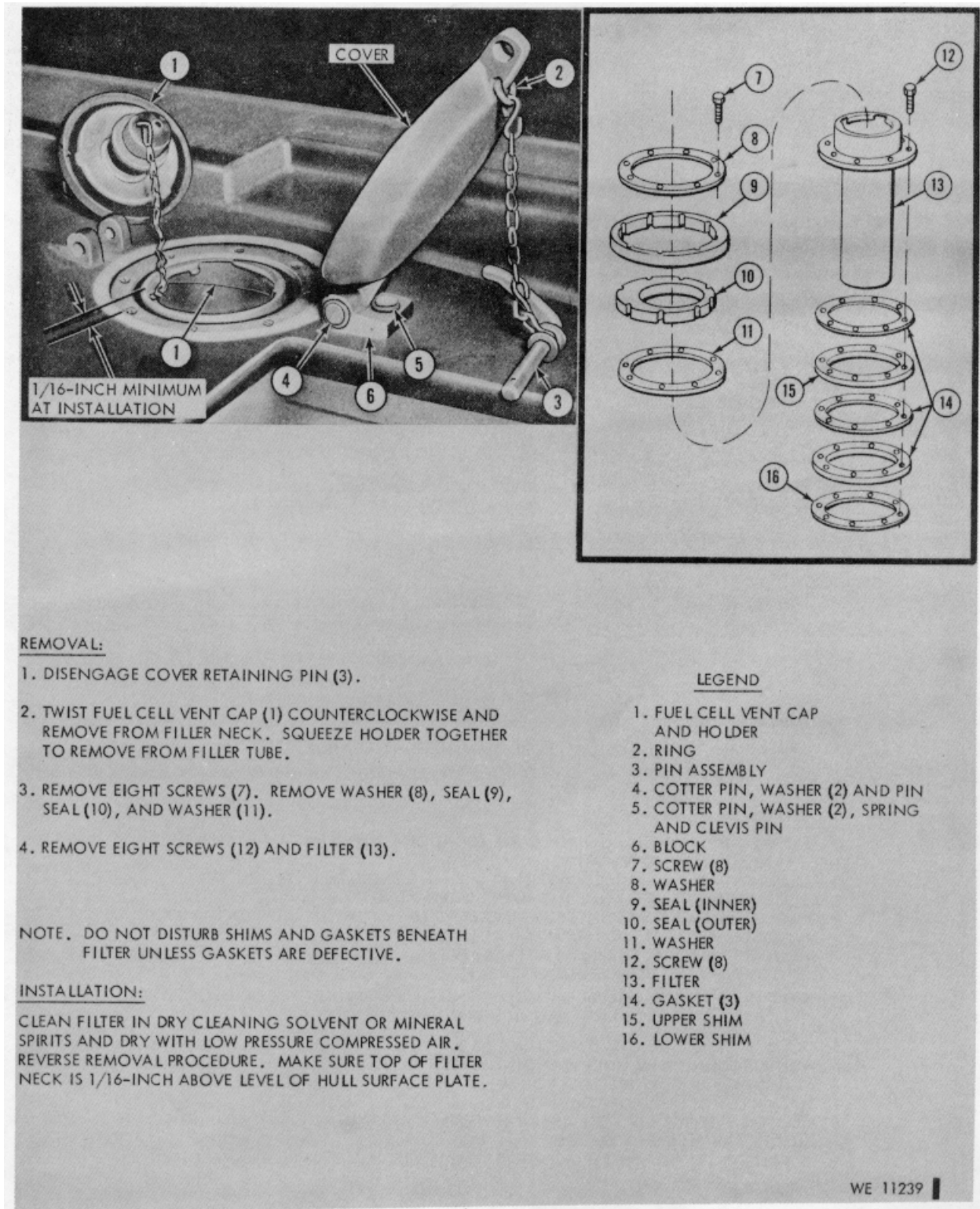
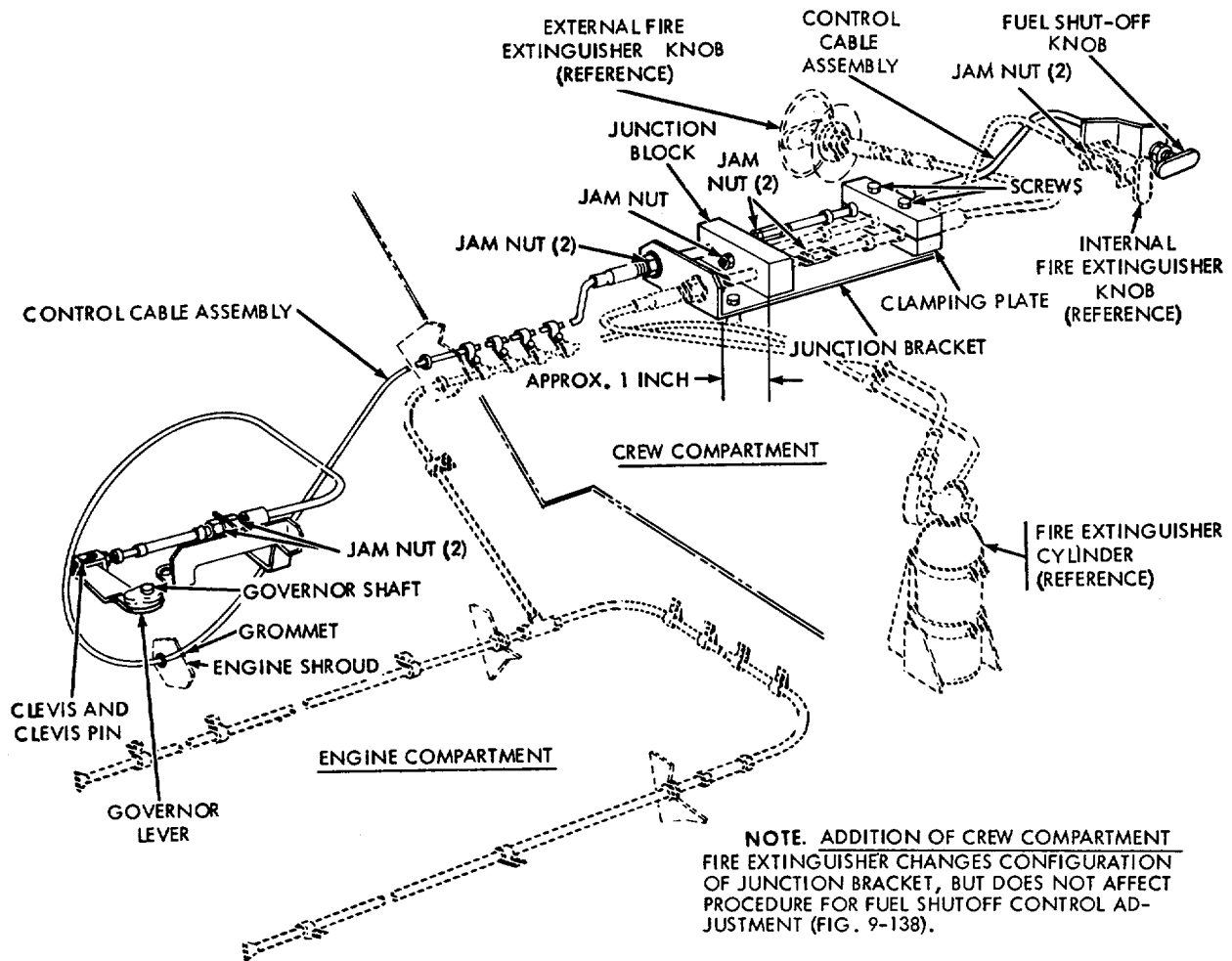

Figure 9-21. Removal/installation - fuel filler cap assembly and filter





#### PRELIMINARY STEPS

- A. OPEN ENGINE EXHAUST GRILLES, REMOVE GRILLE SUPPORT AND ENGINE AIR INLET GRILLE (FIGURE 9-3, STEP 1 THROUGH 2).
- B. REMOVE STEP PLATE (FIGURE 9-23, ITEM 13).

#### ADJUSTMENT

1. REVIEW FIGURE 9-43 FOR CONTROL CABLE LOCATIONAL REFERENCE AND TABLE 9-9.1 FOR CABLE HANDLING PRECAUTIONS.
  2. REMOVE COTTER PIN, AND CLEVIS PIN AT ENGINE GOVERNOR LEVER.
  3. DEPRESS FUEL SHUT-OFF KNOB IN DRIVER'S COMPARTMENT.
  4. CHECK ADJUSTMENTS AT JUNCTION BRACKET TO LEFT OF DRIVER. JUNCTION BLOCK SHOULD BE APPROX. 1 INCH FROM END OF BRACKET. JAM NUTS, ON OUTER CABLES, SHOULD BE AN EQUAL (1/4 INCH) DISTANCE FROM JUNCTION BLOCK. (ADJUST CABLES BY LOOSENING CLAMPING PLATE SCREWS).
- NOTE.** ADJUSTMENT OF FUEL SHUT-OFF CONTROL SYSTEM MUST BE CORRELATED WITH ADJUSTMENT OF FIRE EXTINGUISHER CONTROL (FIGURE 9-138 OR 9-140).
5. ADJUST BACK SIDE OF GOVERNOR LEVER TO 90° WITH CENTER LINE OF VEHICLE.
  6. ADJUST HOUSING JAM NUTS AT ENGINE BRACKET SO THAT CLEVIS PIN WILL DROP IN PLACE WITHOUT BINDING WITH CENTER ROD FULLY EXTENDED (RUN CONDITION).
  7. CHECK ALL JAM NUTS FOR TIGHTNESS.
  8. ADJUST GOVERNOR LEVER CLEVIS SO CLEVIS PIN IS AT REAR END OF SLOTTED HOLE IN CLEVIS, TIGHTEN CLEVIS JAM NUT.
  9. INSTALL COTTER PIN AND REPLACE ITEMS REMOVED IN PRELIMINARY STEPS A AND B.

WE 66682

Figure 9-22. Fuel shut-off control system adjustment

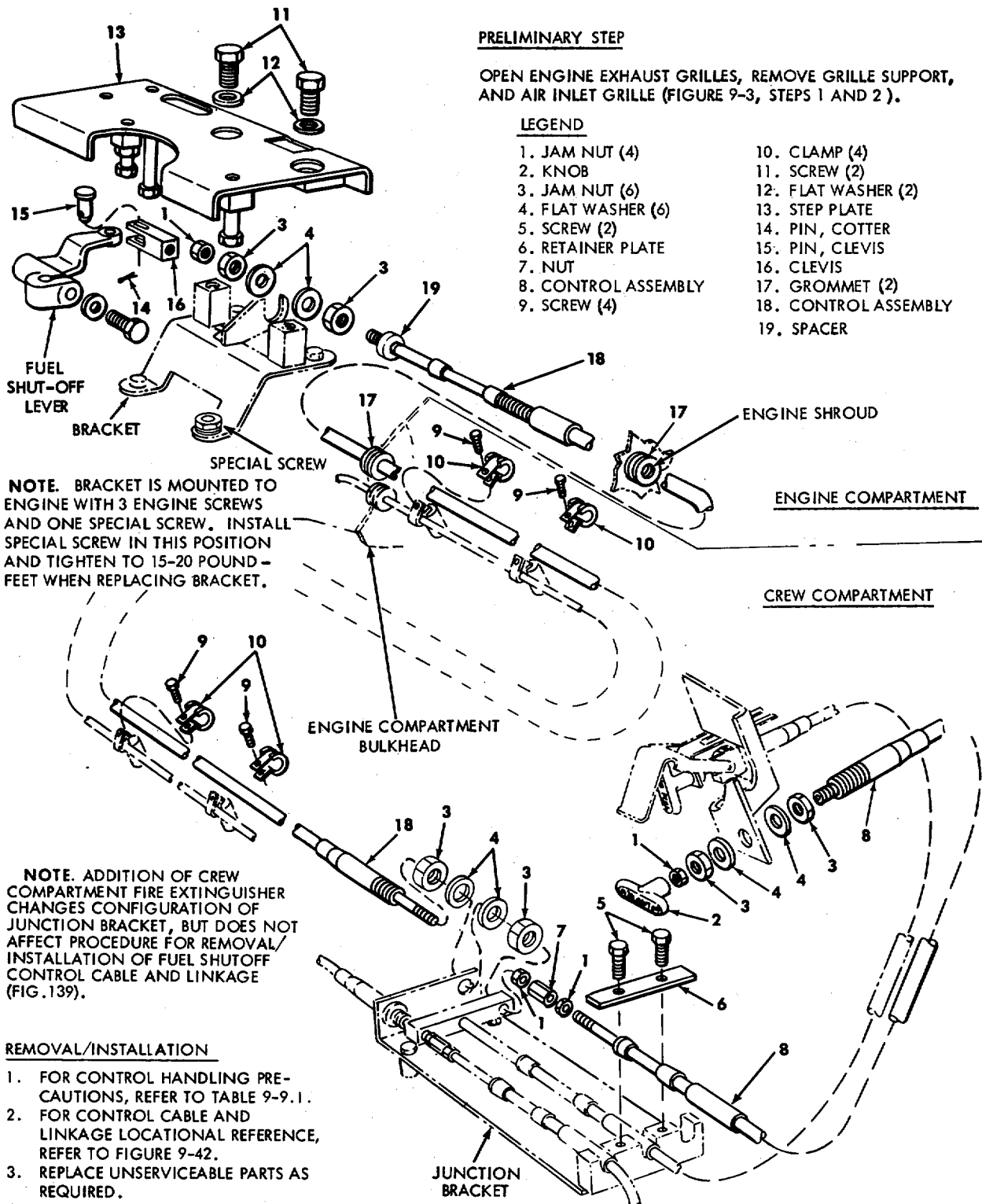

WE 66683

Figure 9-23.. Removal/installation/repair - fuel shut-off control cable and linkage

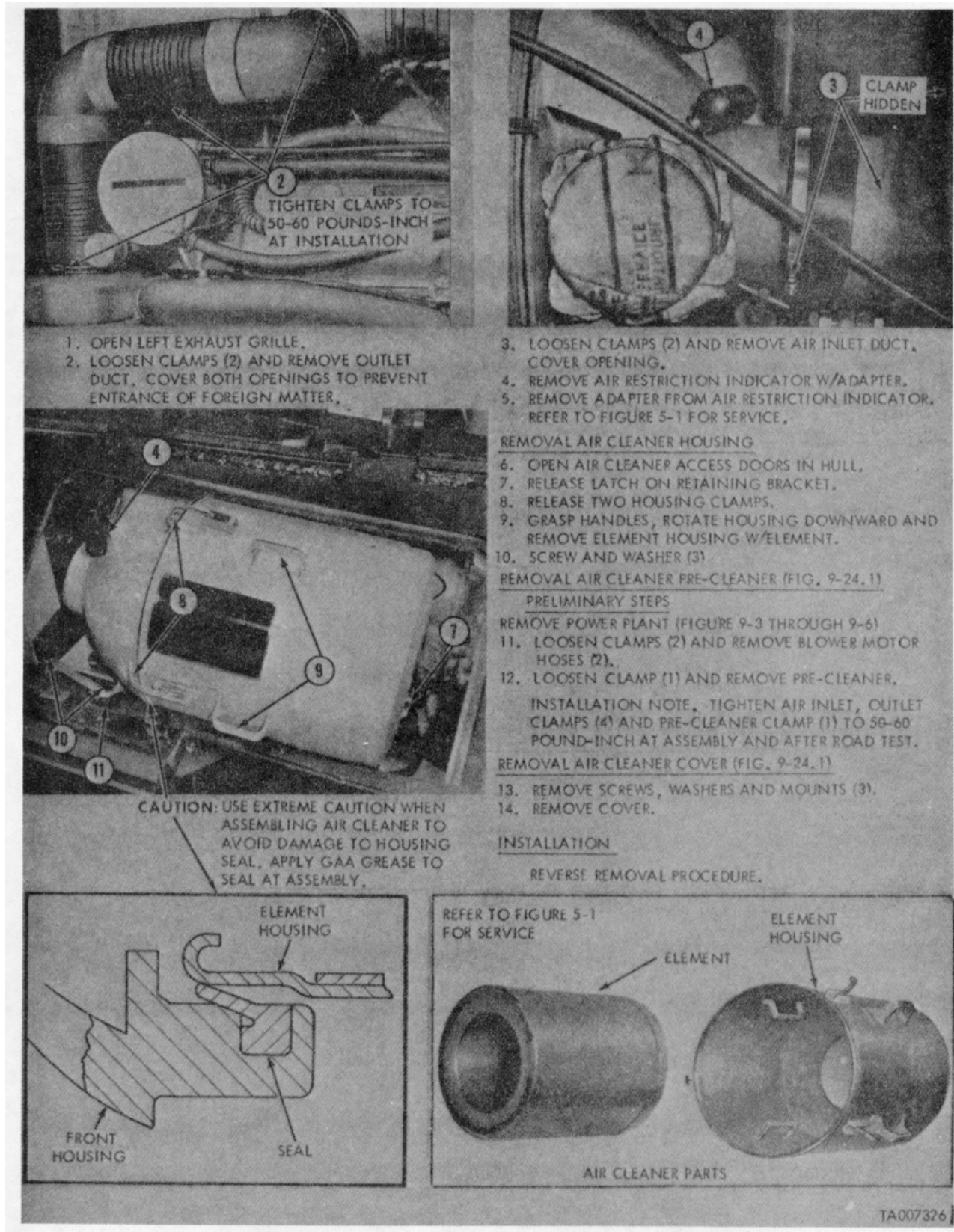
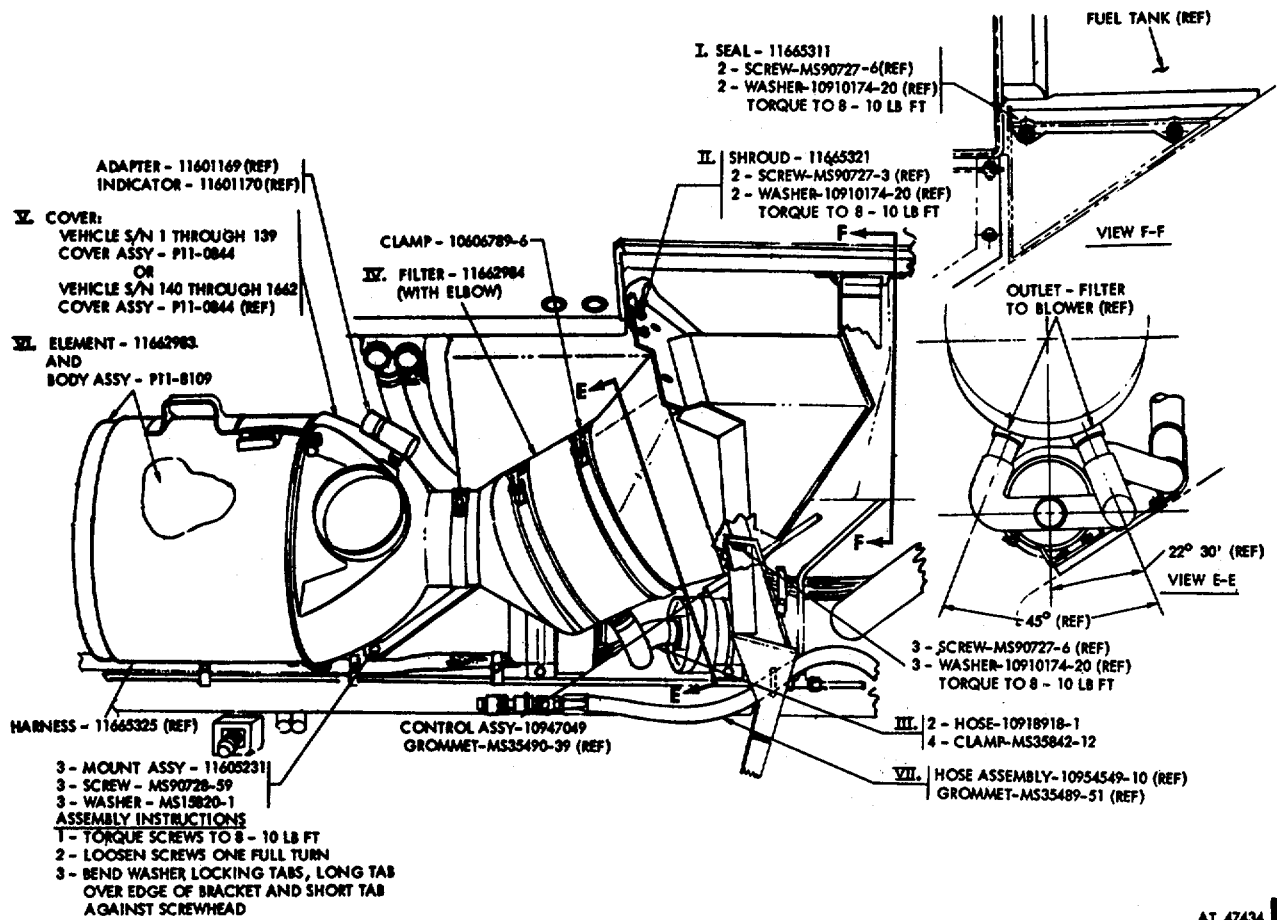

Figure 9-24. Removal/installation - air cleaner, restriction indicator, air cleaner inlet and outlet elbows

INSTALL COMPONENTS IN  
NUMERICAL SEQUENCE I THROUGH VII



AT 47434

Figure 9-24.1. Removal/installation - filter and air cleaner.

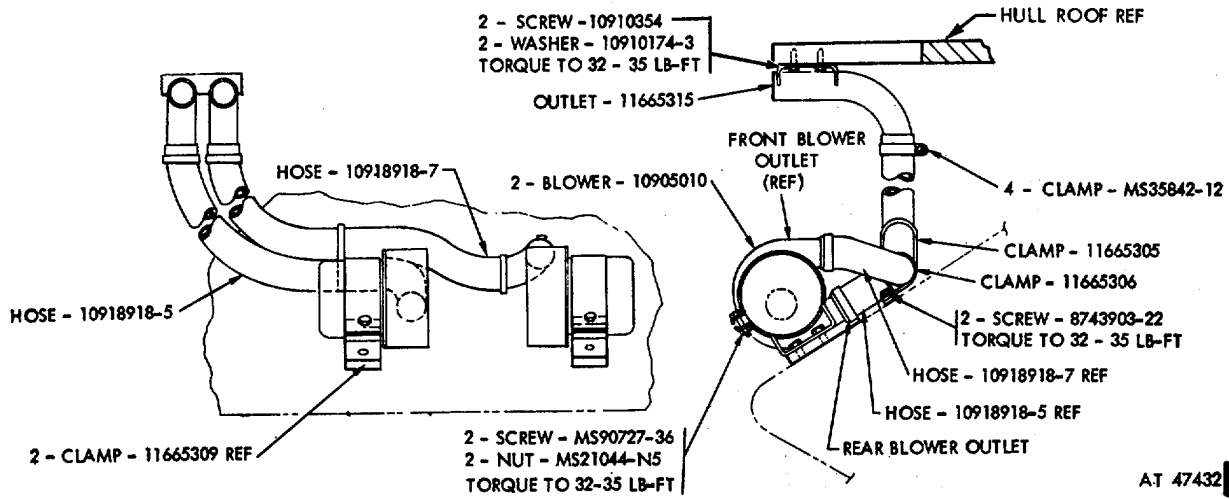

Figure 9-24.2. Removal/installation - blower assembly and hose.

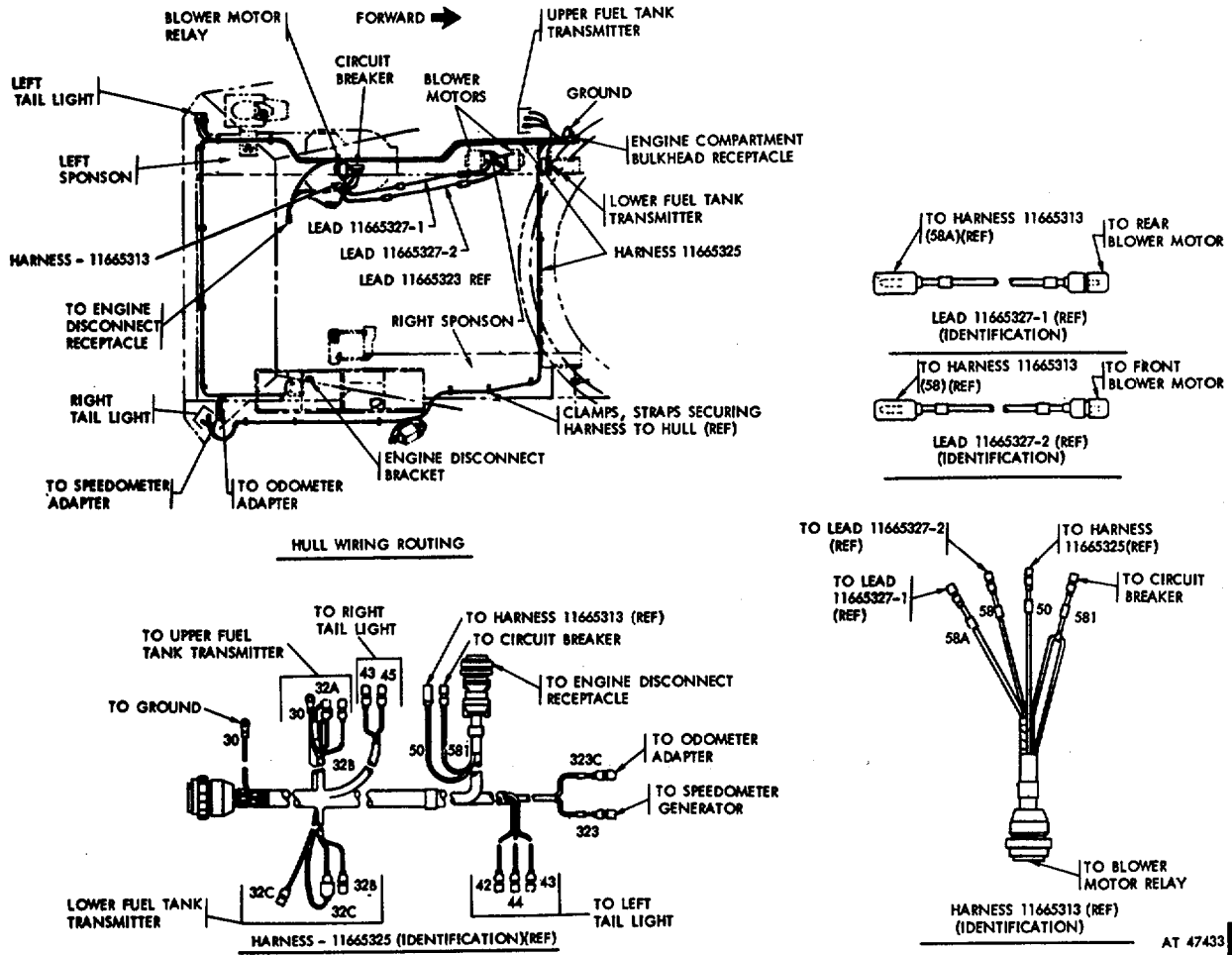
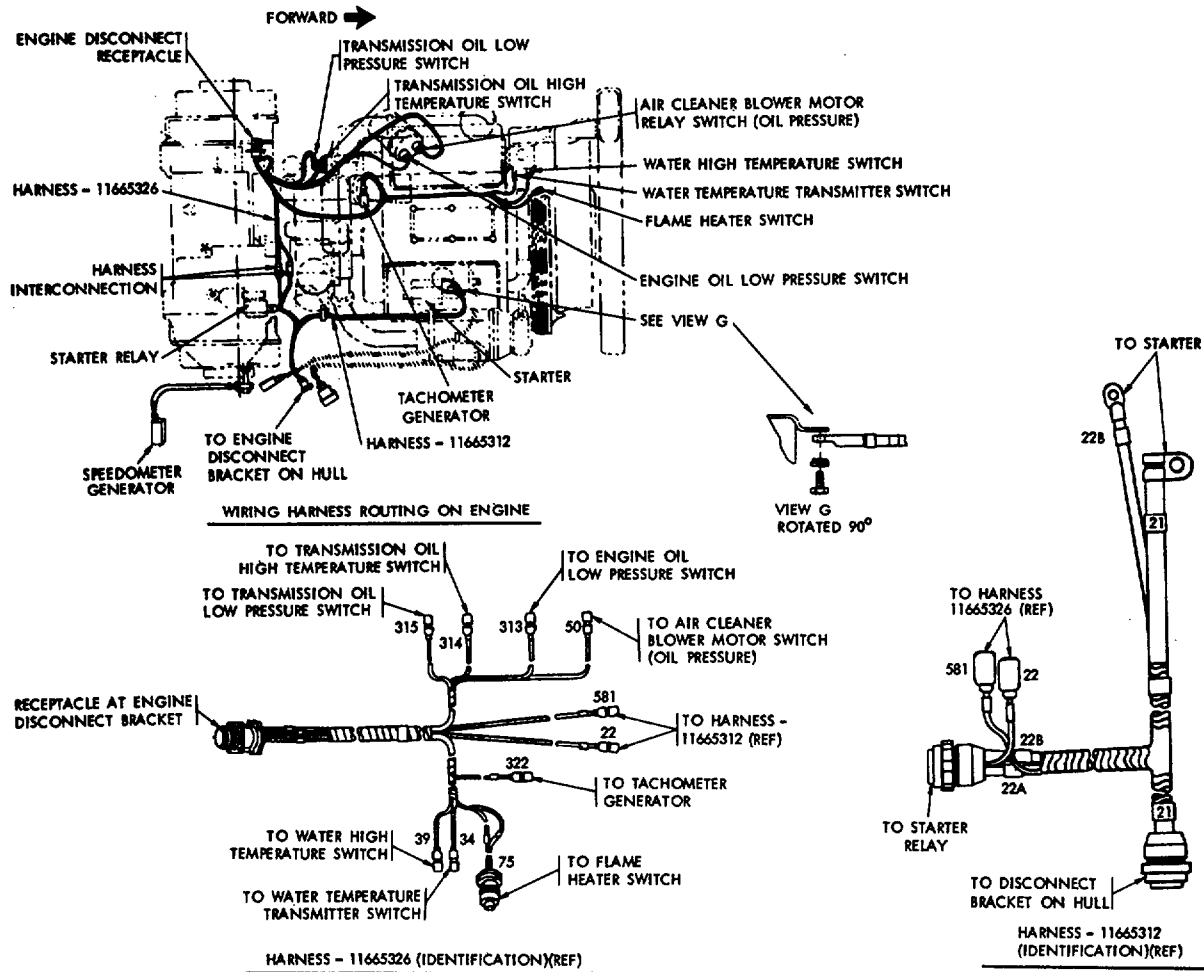
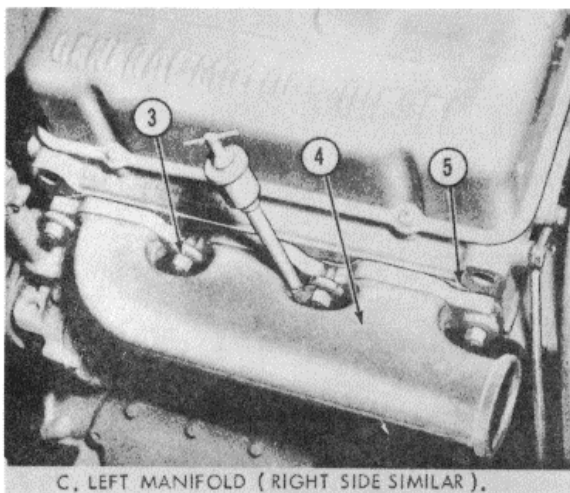
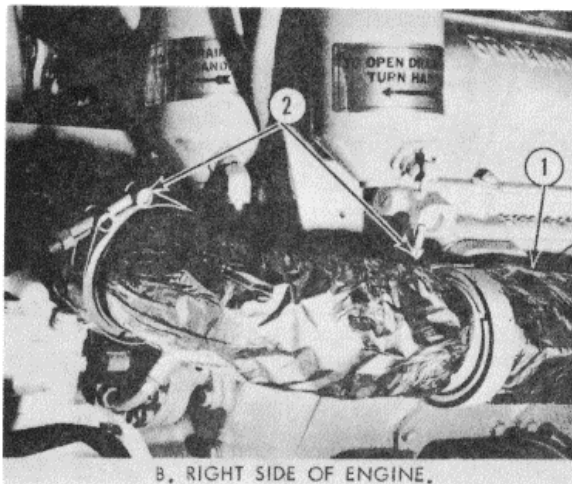
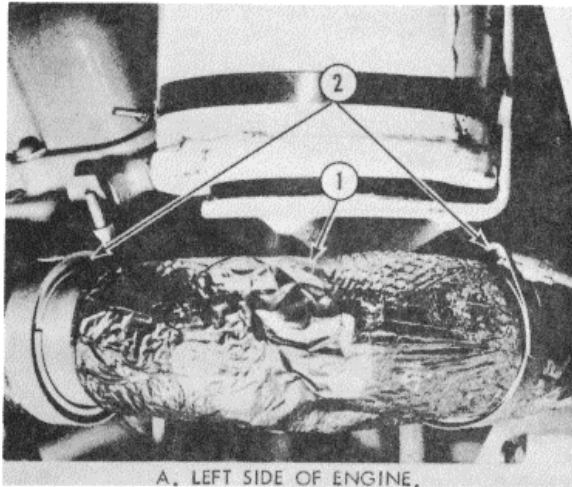

Figure 9-24. 3. Removal/installation - hull wiring harness and leads.



AT 47436

Figure 9-24.4. Removal/installation - engine wiring harness.



PRELIMINARY STEPS

- A. OPEN EXHAUST GRILLES AND REMOVE TWO REAR GRILLE SUPPORT SCREWS (ITEM 2, FIGURE 9-3).
- B. FOLLOW STEPS 3 THROUGH 5, FIGURE 9-3, TO REMOVE ENGINE ACCESS COVER.
- C. REMOVE AIR CLEANER DUCT (STEP 1, TABLE 9-1).

REMOVAL

1. LOOSEN LOCK WIRE AND REMOVE INSULATION FROM MANIFOLDS AND ELBOWS.
2. LOOSEN TWO NUTS, SLIDE GROOVED CLAMP COUPLINGS OVER ELBOW, AND REMOVE ELBOW.  
NOTE. INSTALL CLAMPS WITH SCREWS IN EXACT POSITION SHOWN IN VIEWS A AND B.
3. REMOVE 4 NUTS AND WASHERS FROM MANIFOLD STUDS.  
INSTALLATION NOTE. TIGHTEN NUTS TO 30-35 POUNDS-FEET WITH ENGINE HOT.
4. REMOVE MANIFOLD.
5. REMOVE GASKET FROM ENGINE.

INSTALLATION NOTE. INSTALL NEW GASKETS.

INSTALLATION

REVERSE REMOVAL PROCEDURE.

WE 11235A |

Figure 9-25. Removal/installation - exhaust manifolds and elbows

WE 11235A |



**LEGEND**

- |                       |                        |
|-----------------------|------------------------|
| 1. COUPLING           | 14. BASE               |
| 2. ELBOW INSULATION   | 15. HOOK               |
| 3. LOCK WIRE          | 16. CHAIN              |
| 4. ELBOW ASSY         | 17. PIN                |
| 5. CLAMP              | 18. EXHAUST OUTLET     |
| 6. STRAP              | 19. GASKET             |
| 7. SCREW (2)          | 20. RETAINER           |
| 8. SCREW (2)          | 21. MUFFLER            |
| 9. DIFFUSER ASSY.     | 22. MUFFLER INSULATION |
| 10. SCREW (2)         | 23. CLAMP (2)          |
| 11. SPRING WASHER (2) | 24. PIN (4)            |
| 12. NUT (2)           | 25. COTTER PIN (4)     |
| 13. COVER             | 26. NUT (2)            |
|                       | 27. FLAT WASHER (2)    |

**PRELIMINARY STEPS**

REMOVE 2 REAR SCREWS AND WASHERS FROM GRILLE SUPPORT. REMOVE REAR ENGINE ACCESS COVER AND MUFFLER FROM VEHICLE (STEPS 2 THROUGH 5, FIG. 9-3). PLACE COVER AND MUFFLER ON SUITABLE BLOCKS (C, FIG. 9-6).

REPLACE UNSERVICEABLE COMPONENTS AS REQUIRED.  
CLEAN ELBOW AS EXPLAINED IN NOTE.

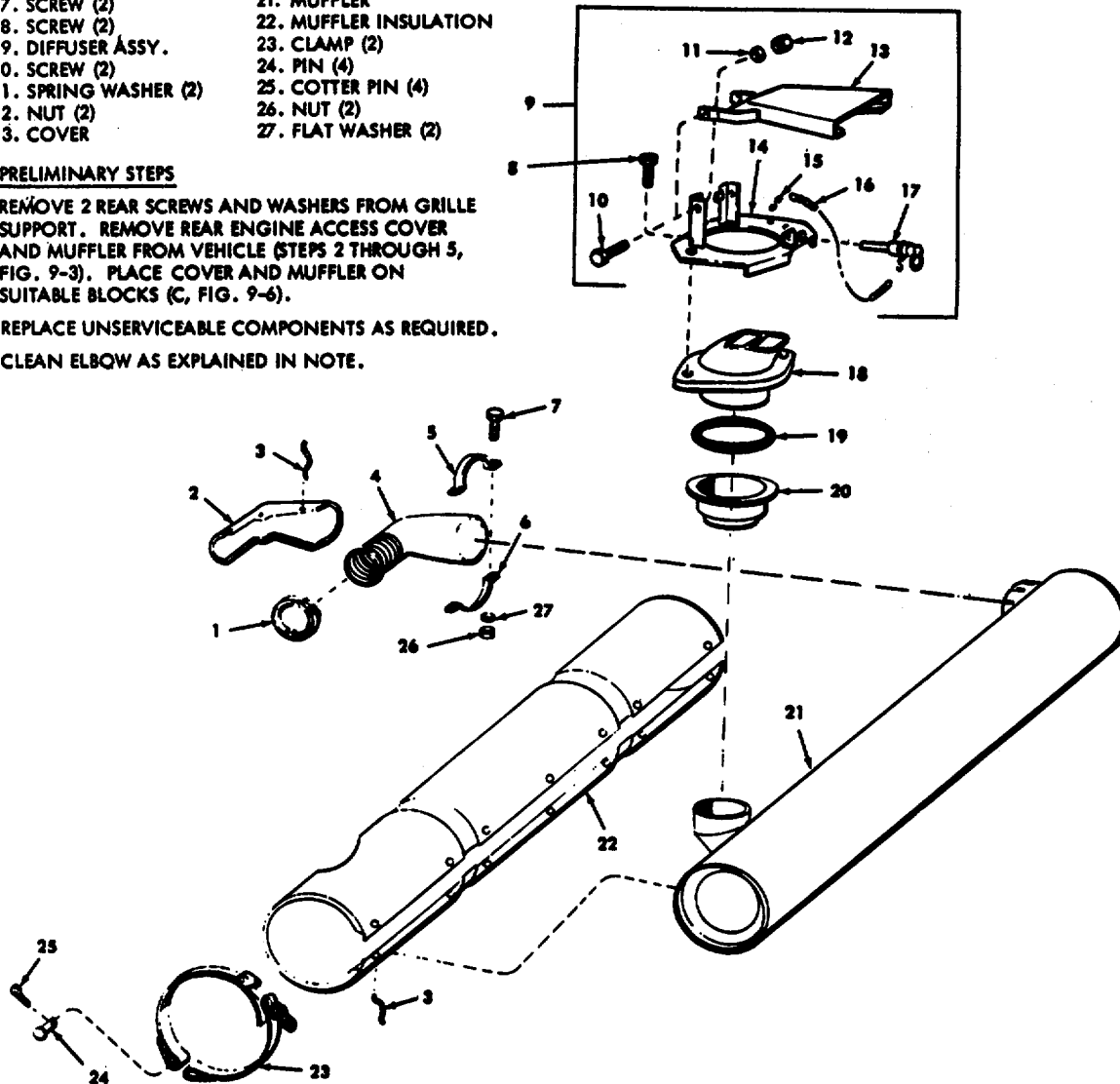

**CLEANING NOTE.** REMOVE ELBOW (4) FROM MUFFLER AND APPLY DIESEL FUEL TO THE OUTSIDE OF THE FLEXIBLE SECTION. ALLOW TIME FOR THE FUEL TO PENETRATE, THEN FLEX TUBE TO DISLodge CARBON. EMPTY CARBON FROM ELBOW, AND REINSTALL ELBOW.

TA007327

Figure 9-26. Removal/installation/repair - eyhan8t muffler and components.

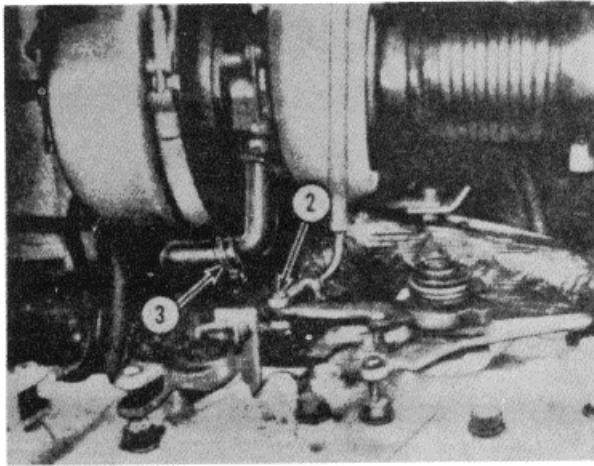

#### REMOVAL

1. FOLLOW STEPS 2 THROUGH 5, FIGURE 9-3, TO REMOVE EXHAUST GRILLE SUPPORT AND ENGINE ACCESS COVER. LOOSEN CLAMPS (2) AND REMOVE AIR CLEANER-TO-TURBOCHARGER DUCT (ITEM 1, TABLE 9-1).
2. REMOVE COTTER PIN, STRAIGHT PIN, AND DISENGAGE THROTTLE VALVE ROD FROM LEVER.
3. LOOSEN CLAMP AND DISCONNECT LUBRICATING OIL DRAIN HOSE.

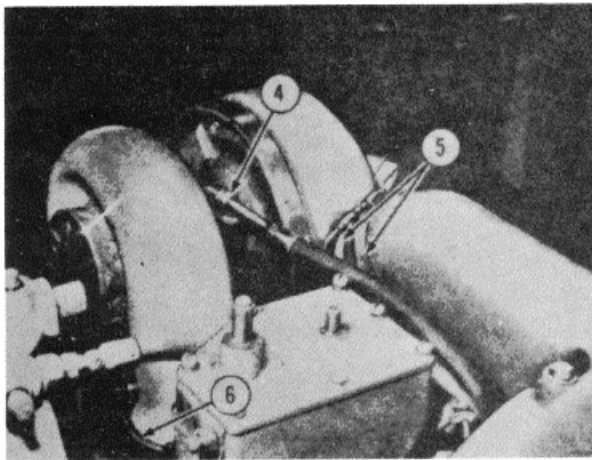

4. LOOSEN NUT AND DISCONNECT LUBRICATING OIL SUPPLY TUBE.
- INSTALLATION NOTE. CONNECT ITEM 3 PRIOR TO ITEM 4. POUR IN 2 OUNCES OF CLEAN LUBRICATING OIL TO LUBRICATE TURBOCHARGER BEARING.
5. LOOSEN 2 CLAMPS AND SLIDE TURBOCHARGER AIR INTAKE HOSE OFF TURBOCHARGER.
  6. LOOSEN CLAMP AND LIFT OFF TURBOCHARGER.

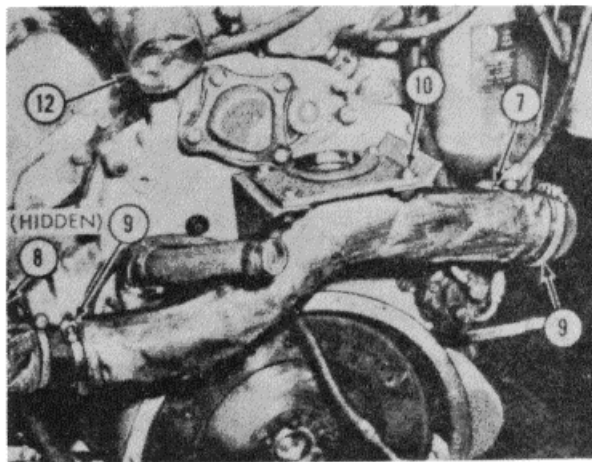

7. LOOSEN LOCK WIRE AND REMOVE CROSSOVER PIPE INSULATION.
8. LOOSEN, BUT DO NOT REMOVE, CLAMPS CONNECTING ELBOWS TO LEFT AND RIGHT EXHAUST MANIFOLDS.
9. LOOSEN AND DISCONNECT CLAMPS ATTACHING CROSSOVER PIPE TO EXHAUST ELBOWS.
10. REMOVE 4 SCREWS AND LOCK WASHERS FROM TURBOCHARGER SUPPORT BASE.
11. SLIDE CROSSOVER PIPE FORWARD TO CLEAR SUPPORT BRACKET AND REMOVE.
12. COVER ENGINE BLOWER INLET OPENING.

#### INSTALLATION

REVERSE REMOVAL PROCEDURE.

WE 11040B

WE 11040B

Figure 9-27. (Superseded) Removal/installation - exhaust crossover pipe

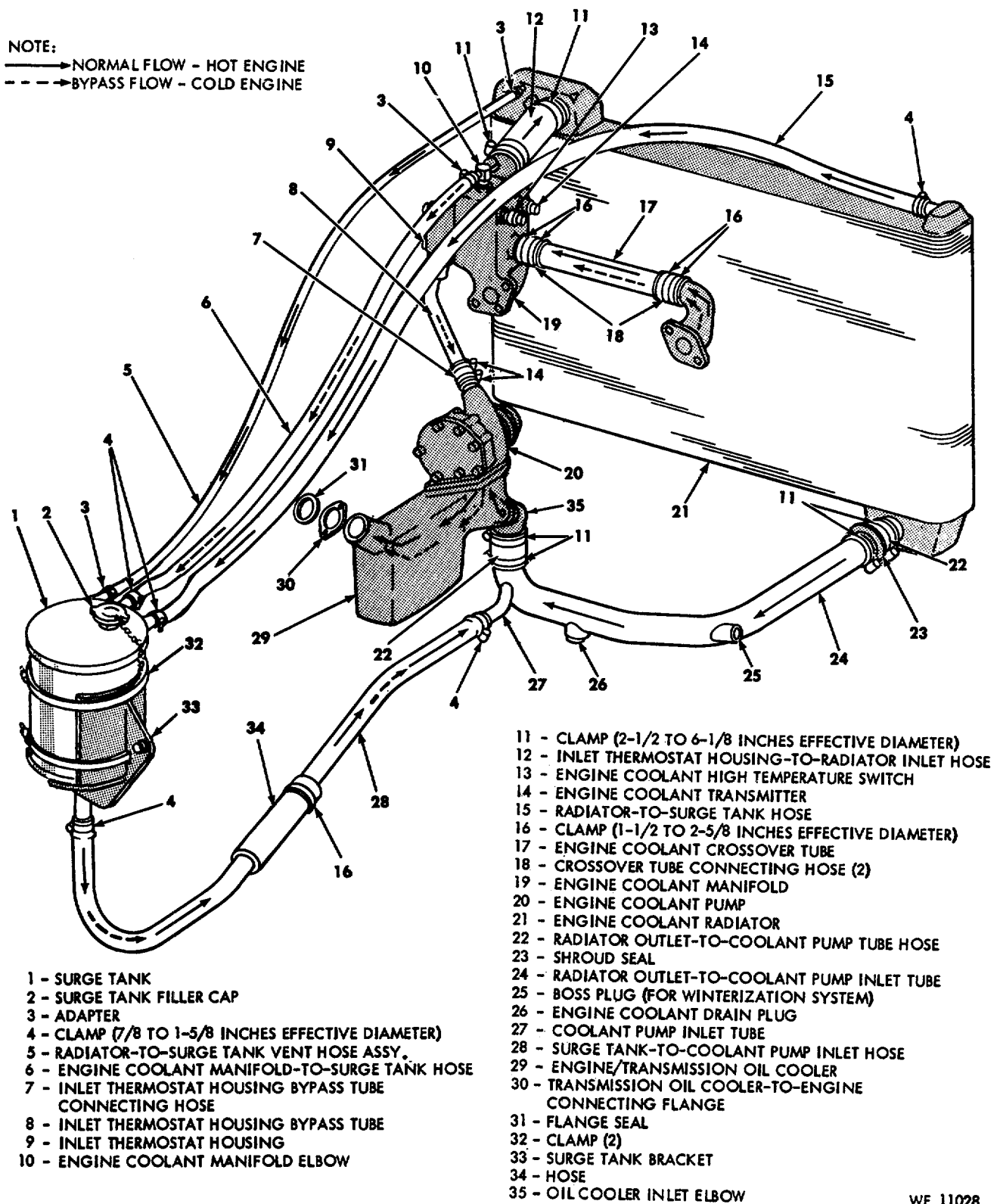
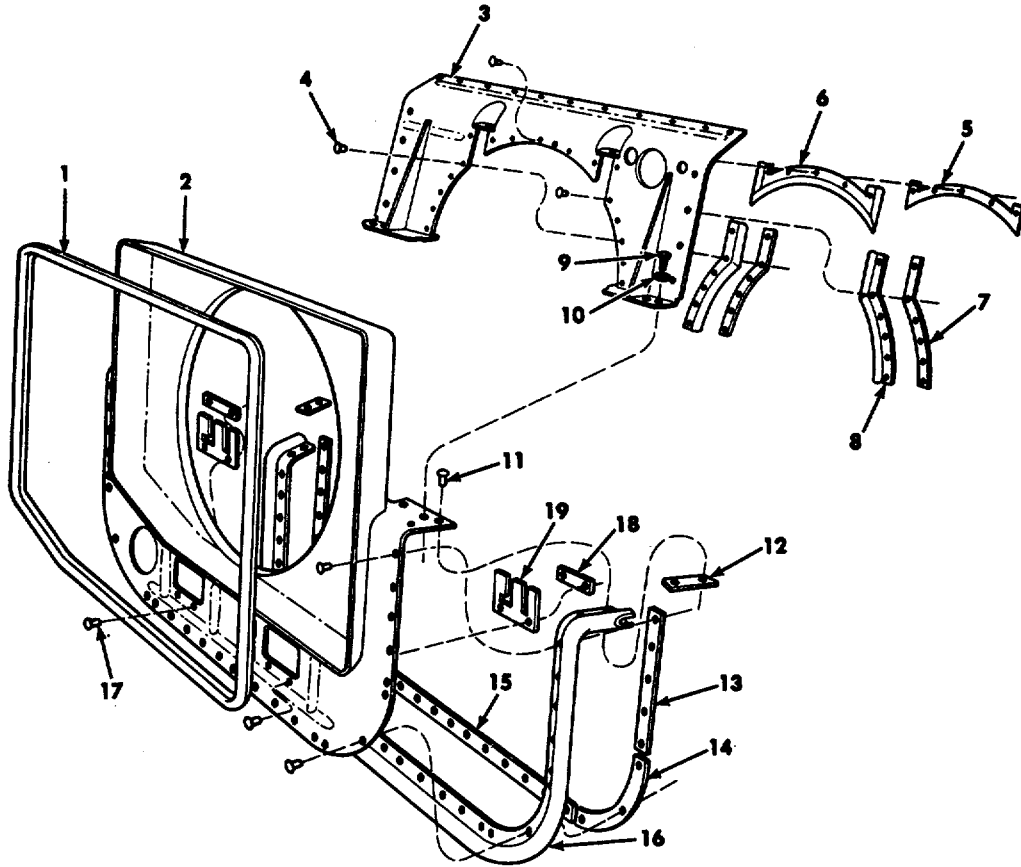

Figure 9-28. Engine coolant system - schematic view

PRELIMINARY STEPS

1. REMOVE POWER PLANT (FIGURES 9-3 THROUGH 9-6).
2. DRAIN ENGINE COOLANT (TABLE 5-4).
3. REMOVE RADIATOR (FIGURE 9-30 AND 9-31).

LEGEND

1. SEAL
2. FAN SHROUD
3. UPPER SHROUD
4. RIVET (18)
5. PLATE
6. SEAL
7. PLATE (2)
8. SEAL (2)
9. SCREW (4)
10. WASHER (4)
11. RIVET (30)
12. PLATE (2)
13. PLATE (2)
14. PLATE (2)
15. PLATE
16. SEAL
17. RIVET (4)
18. PLATE (2)
19. SEAL (2)

REMOVAL

1. REMOVE FOUR SCREWS (ITEM 9), WASHERS (ITEM 10), AND LIFT OFF UPPER SHROUD (ITEM 3) AND FAN SHROUD ASSEMBLY (ITEM 2).
2. REMOVE DAMAGED SEAL(S) TO BE REPLACED.

INSTALLATION

REVERSE REMOVAL PROCEDURE.

**NOTE.** WHEN REPLACING FAN SHROUD SEALS, MAKE SURE MOUNTING SURFACES ARE FREE OF DIRT, PAINT, BURRS AND SHARP EDGES. COAT MOUNTING SURFACES WITH ADHESIVE-8040-664-4318. REFER TO PARAGRAPH 8-6.

REFER TO FIGURE 9-142.1 FOR REMOVAL AND INSTALLATION OF RADIATOR CONTAMINATION SHIELD AND GRILLE DEBRIS SCREENS.

WE11110A

Figure 9-29. (Superseded) Removal/installation/repair - radiator cooling fan shrouds and shroud seals

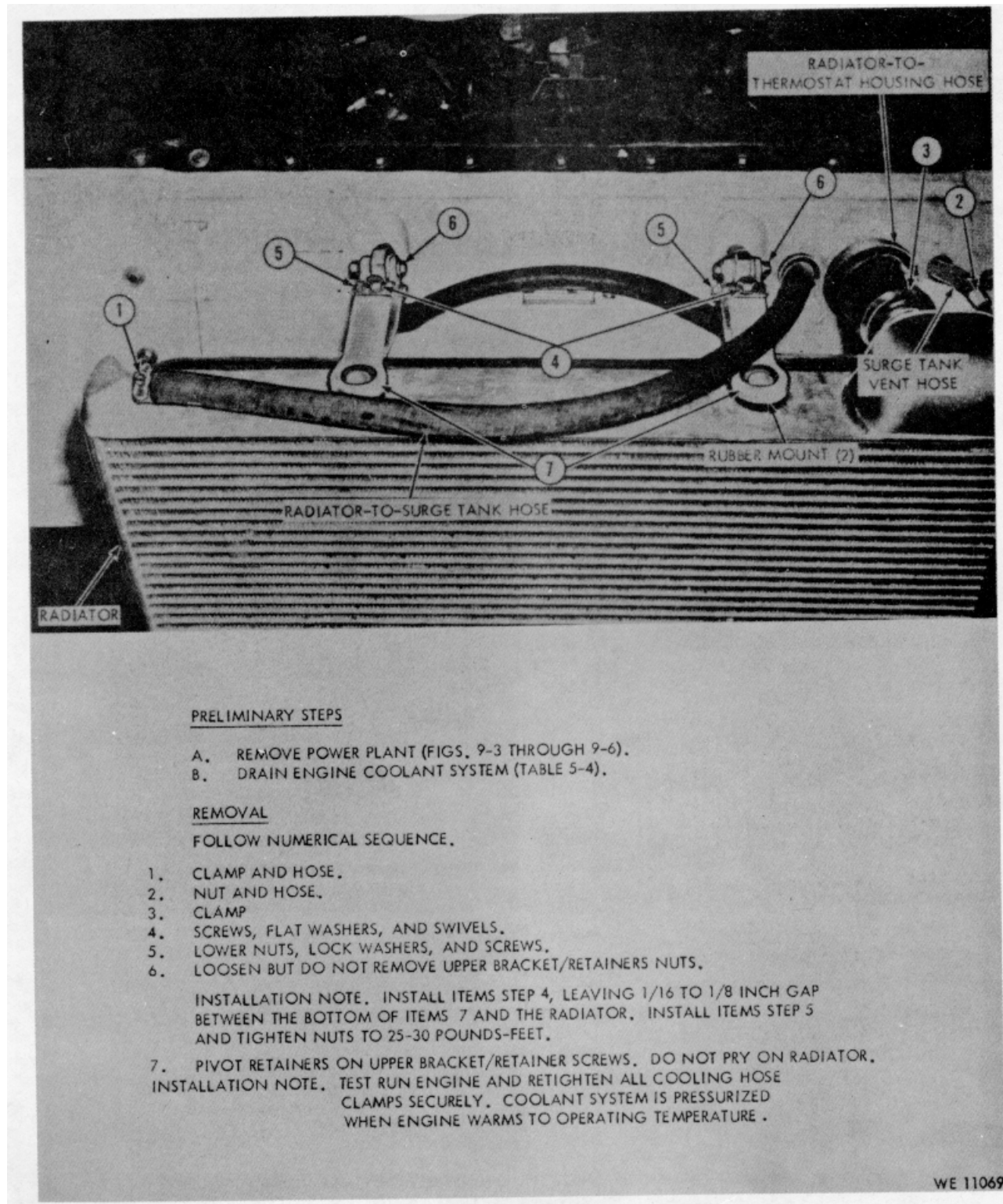

Figure 9-30. Removal/installation - engine coolant radiator (1 of 2)

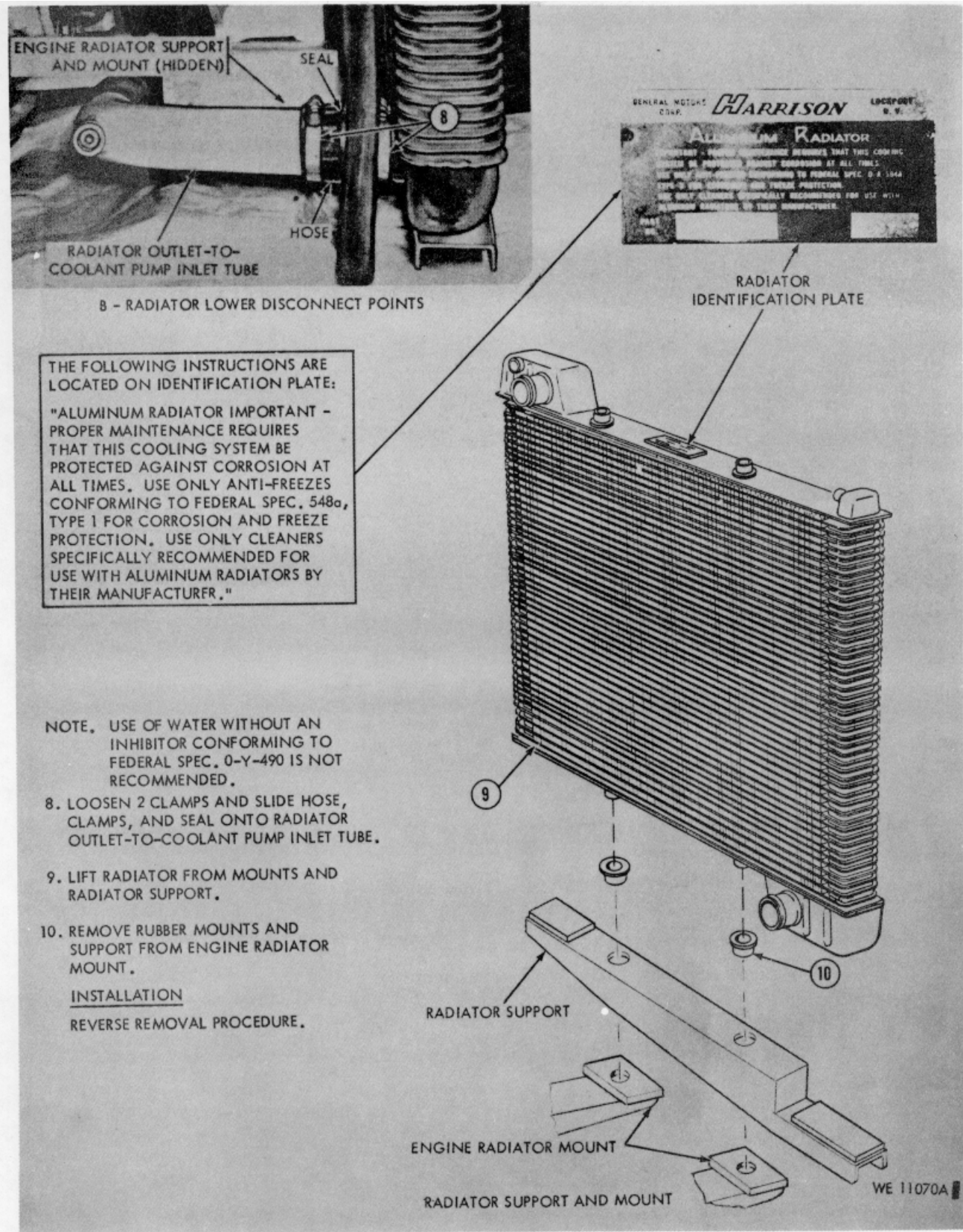
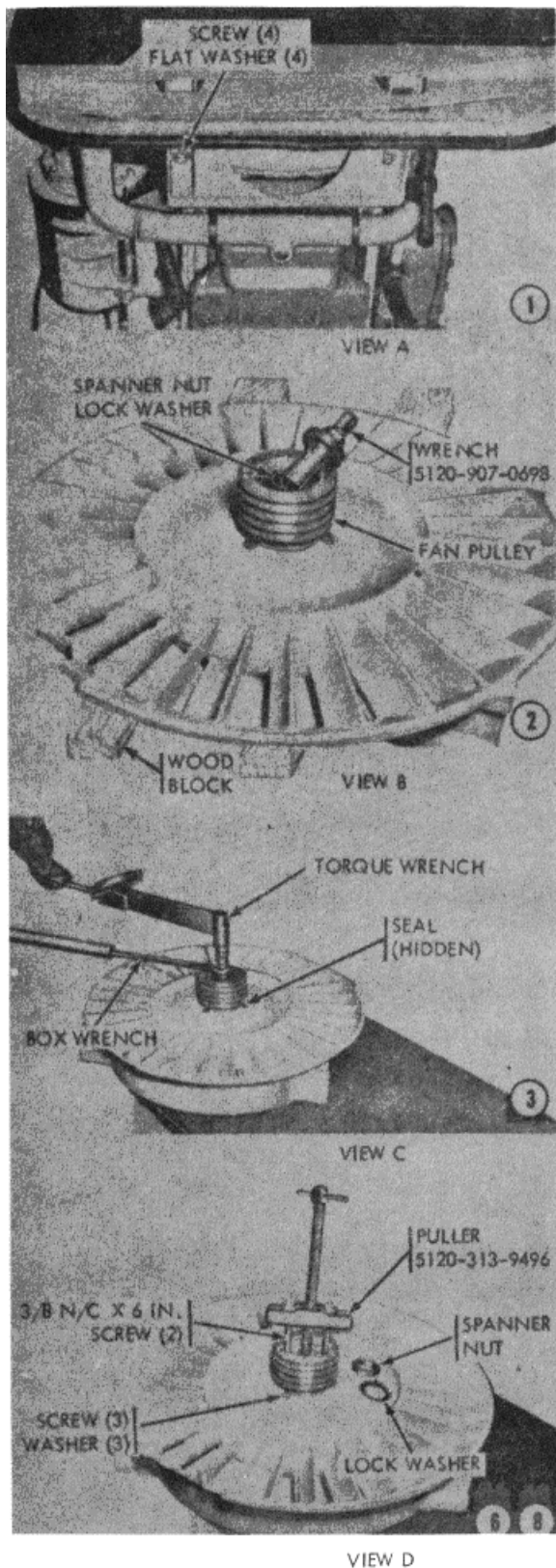

Figure 9-31. Removal/installation - engine coolant radiator (2 of 2)





#### PRELIMINARY STEPS

- A. REMOVE POWER PLANT (FIGS. 9-3 THROUGH 9-6).
- B. DRAIN ENGINE COOLANT SYSTEM.
- C. REMOVE FAN/GENERATOR DRIVE BELTS (FIG. 9-109).
- D. REMOVE RADIATOR (FIGS. 9-30 AND 9-31).
- E. REMOVE UPPER SHROUD AND FAN SHROUD (FIG. 9-29).

#### REMOVAL

FOLLOW STEPS 1 THROUGH 8.  
(CIRCLED NUMBERS REFER TO REMOVAL STEPS).

**CAUTION:** FAN ASSEMBLY MUST BE SUPPORTED AS SHOWN IN VIEW B TO PREVENT DAMAGE TO HEAT SENSING ELEMENT AT CENTER OF FAN CLUTCH ASSEMBLY.

1. REMOVE 4 SCREWS AND FLAT WASHERS AND LIFT COOLING FAN FROM SUPPORT.
  2. UNLOCK LOCK WASHER AND INSTALL FAN PULLEY WRENCH 5120-907-0698 IN FAN CLUTCH SHAFT WITH KEYWAY ENGAGED ON KEY IN SHAFT AND SPANNER WRENCH TEETH ENGAGED IN CLUTCH SHAFT SPANNER NUT.
  3. USE 2 STANDARD BOX WRENCHES AND PIPE EXTENSIONS TO REMOVE FAN PULLEY NUT.
- NOTE:** TIGHTEN NUT TO 210 POUND-FEET WHEN INSTALLING PULLEY.
4. OBTAIN WASHER - 5310-999-9438 (3/4 ID, 1.687 OD) AND SCREW - 5305-922-7994 (OR ANY 3/4" SCREW NOT LONGER THAN 2-1/2").
  5. PLACE WASHER OVER END OF HOLLOW FAN CLUTCH SHAFT AND DROP SCREW THROUGH HOLE IN WASHER TO PROVIDE BEARING SURFACE FOR PULLER SCREW.
  6. INSTALL PULLER - 5120-313-9496 WITH TWO 3/8NC x 6 INCH SCREWS. OMIT STEP 7 WHEN REMOVING ALUMINUM PULLEYS.
  7. MARK END OF PULLEY HUB WITH 450° CRAYON - 6685-255-9523. APPLY HEAT TO OUTER FLANGES, MOVING HEAT SOURCE AROUND PULLEY CIRCUMFERENCE TO AVOID DISTORTION.
- NOTE:** DO NOT APPLY HEAT TO PULLEY HUB AS THIS WILL EXPAND FAN CLUTCH SHAFT.
8. WHEN CRAYON MELTS, TIGHTEN PULLER TO REMOVE PULLEY AND KEY.

#### INSTALLATION

COAT SEAL AND SHAFT WITH HIGH TEMPERATURE GREASE (GMD, 9150-223-4001). MARK BACK OF HUB WITH 450° CRAYON - 6685-255-9523. APPLY HEAT TO FRONT OF HUB, MOVING HEAT SOURCE AROUND HUB TO AVOID DISTORTION. WHEN CRAYON MELTS, TAP PULLEY ONTO FAN CLUTCH SHAFT WITH SOFT METAL HAMMER. REVERSE STEPS 3, 2, AND 1.

WE 12188

Figure 9-32. Removal/installation - radiator coolant fan and pulley

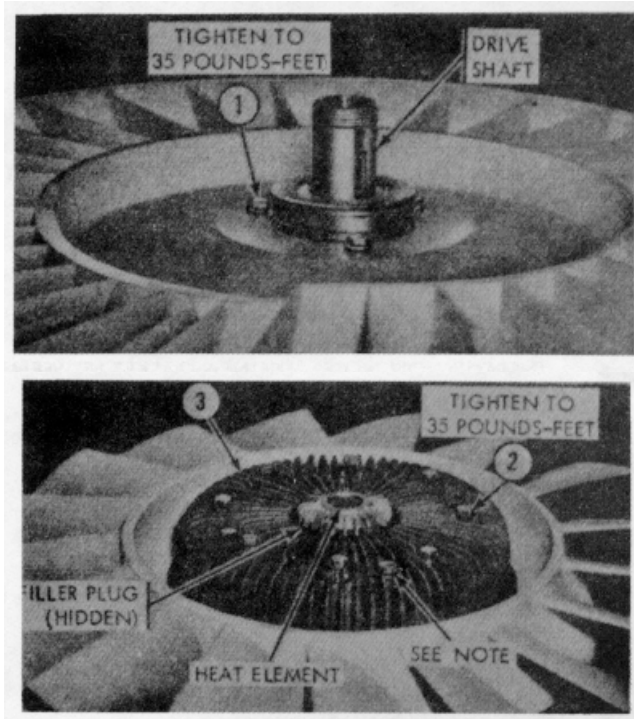

Figure 9-33. Removal/installation - engine coolant for assembly

REMOVAL

1. REMOVE 3 SCREWS AND WASHERS ON FAN DRIVE SHAFT BEARING RETAINER AND REMOVE FAN ROTOR FROM FAN STATOR.

2. REMOVE 8 SCREWS AND WASHERS.

NOTE. DO NOT REMOVE 4 SCREWS WHICH ARE PART OF FAN CLUTCH ASSEMBLY.

3. REMOVE FAN CLUTCH AND RETAINER/BEARING ASSEMBLY FROM ROTOR. REFER TO SUPPORTING MAINTENANCE FOR REPAIR OF CLUTCH OR BEARINGS.

INSTALLATION

REVERSE REMOVAL PROCEDURE.

INSTALLATION NOTE. CHECK CLUTCH FLUID LEVEL. AFTER ABOVE INSTALLATION PLACE FAN ASSEMBLY IN VERTICAL POSITION. ROTATE DRIVE SHAFT UNTIL FILLER PLUG IS VISIBLE. ROTATE ROTOR AND SHAFT UNTIL PLUG IS AT 12 O'CLOCK. REMOVE PLUG AND SLOWLY ROTATE ROTOR. FLUID SHOULD BE VISIBLE AT THE 3:30 O'CLOCK POSITION. IF REQUIRED ADD DAMPING FLUID-SILICONE BASE, 9150-543-7219 UNTIL FLUID IS VISIBLE AT 3:30 POSITION. CHECK FACE OF HEAT ELEMENT FOR EVIDENCE OF LEAKAGE.

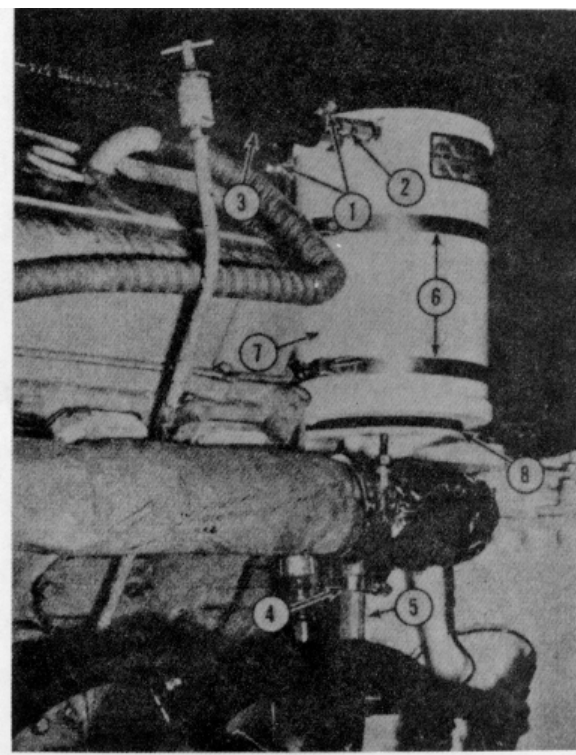

Figure 9-34. Removal/installation - coolant system surge tank

PRELIMINARY STEP

OPEN LEFT ENGINE COMPARTMENT GRILLE DOOR. REMOVE AIR CLEANER-TO-TURBOCHARGER DUCT, FIG. 9-24. DRAIN COOLANT SYSTEM, TABLE 5-4.

LEGEND

- 1. CLAMP (2) UPPER
- 2. NUT AND VENT HOSE
- 3. HOSE (2) UPPER
- 4. CLAMP - LOWER
- 5. HOSE - LOWER
- 6. CLAMP (2)
- 7. SURGE TANK
- 8. SCREW (3), WASHER (3), AND BRACKET

REMOVAL

FOLLOW NUMERICAL SEQUENCE. DO NOT USE SCREW DRIVER TO REMOVE HOSES.

INSTALLATION

REVERSE NUMERICAL SEQUENCE.

**CAUTION:** TEST RUN ENGINE AND RETIGHTEN ALL COOLANT HOSE CLAMPS SECURELY. COOLANT SYSTEM IS PRESSURIZED WHEN ENGINE WARMS TO OPERATING TEMPERATURE.



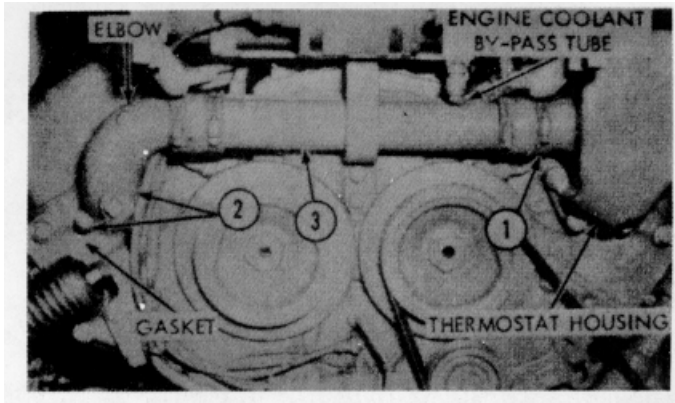

PRELIMINARY STEPS

- A. REMOVE POWER PLANT (FIGS. 9-3 THROUGH 9-6)
- B. DRAIN COOLANT SYSTEM

REMOVAL - ENGINE COOLANT BY-PASS TUBE

1. LOOSEN CLAMP FASTENING HOSE TO THERMOSTAT HOUSING
2. REMOVE 2 SCREWS AND 2 WASHERS FASTENING ELBOW TO ENGINE.
3. REMOVE TUBE AND ELBOW ASSEMBLY.

**NOTE.** DO NOT USE SCREWDRIVER TO REMOVE ANY HOSES ON COOLANT SYSTEM, INSTALLATION NOTE. USE NEW GASKET BETWEEN ELBOW AND ENGINE.

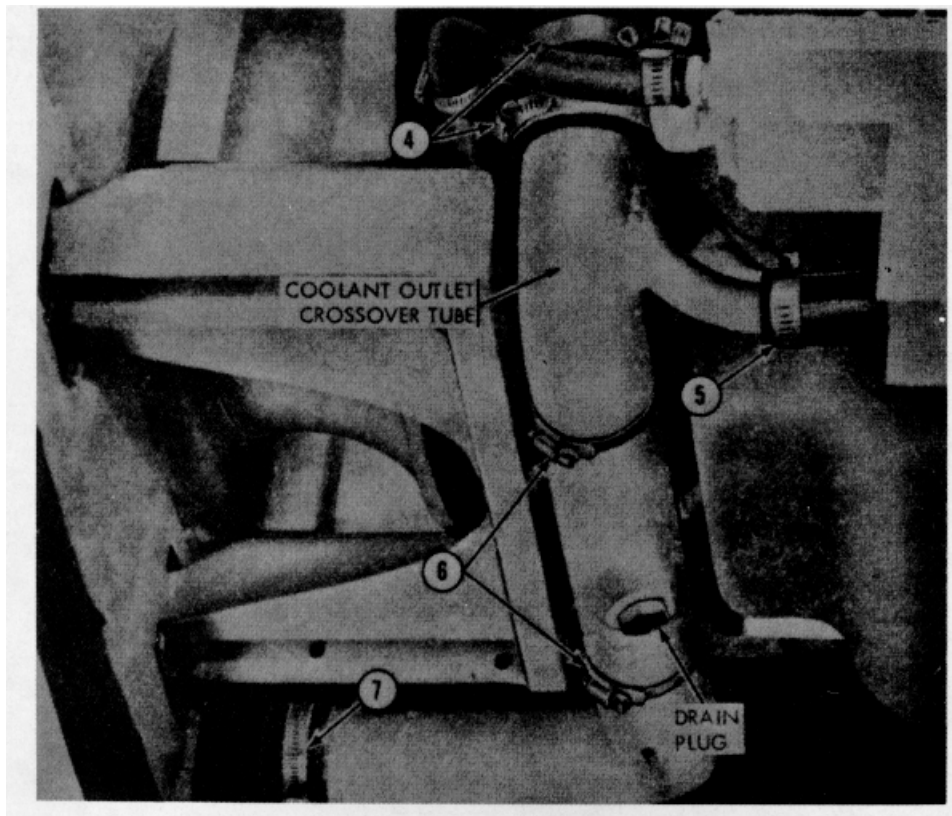

REMOVAL - COOLANT OUTLET CROSSOVER TUBE

4. LOOSEN 2 CLAMPS ON WATER PUMP INLET HOSE AND SLIDE HOSE OFF PUMP.
5. LOOSEN CLAMP ON SURGE TANK HOSE AND SLIDE HOSE OFF TUBE.
6. LOOSEN 2 CLAMPS ON COOLANT TUBE MOUNT SUPPORT AND SLIDE OFF BRACKET.
7. LOOSEN 2 CLAMPS ON RADIATOR OUTLET HOSE AND SLIDE HOSE, CLAMP, AND SEAL ONTO COOLANT TUBE.

**NOTE:** DO NOT USE SCREWDRIVER TO REMOVE ANY COOLANT HOSE. IT CAN DAMAGE HOSE OR TUBES.

INSTALLATION

REVERSE REMOVAL PROCEDURE.  
TEST RUN ENGINE TO OPERATING TEMPERATURE AND RETIGHTEN ALL COOLANT HOSE CLAMPS SECURELY TO PREVENT LEAKS.

WE 10960

Figure 9-35. Removal/installation - engine coolant tubes, hoses, and clamps

**PRELIMINARY STEPS**

REMOVE POWER PLANT (FIGURE 9-3 THROUGH 9-6).

B. DRAIN ENGINE COOLANT SYSTEM (TABLE 5-4).

**REMOVAL**

1. LOOSEN 2 SCREWS, ROTATE BELT ADJUSTING BRACKET CLOCKWISE TO RELIEVE TENSION ON PUMP DRIVE BELTS AND REMOVE BELTS.
2. LOOSEN 2 SCREWS ON HOSE CLAMPS AND SLIDE CLAMPS AND HOSE UPWARDS ON ENGINE THERMOSTAT HOUSING BYPASS TUBE.
3. REMOVE SOCKET-HEAD SCREW AND 4 SCREWS, LOCK WASHERS, AND FLAT WASHERS. REMOVE COOLANT PUMP AND GASKET FROM ENGINE.

**INSTALLATION**

REVERSE REMOVAL SEQUENCE AND ADJUST BELTS. INSTALL NEW GASKET.

**BELT ADJUSTMENT**

PIVOT BELT ADJUSTING BRACKET UNTIL BELTS CAN BE DEPRESSED 1/4 INCH FROM STRAIGHT EDGE WITH FIVE TO TEN POUNDS PRESSURE. IF FULL COUNTERCLOCKWISE MOVEMENT OF ADJUSTING BRACKET WILL NOT PROVIDE PROPER BELT ADJUSTMENT, REPLACE BOTH BELTS.

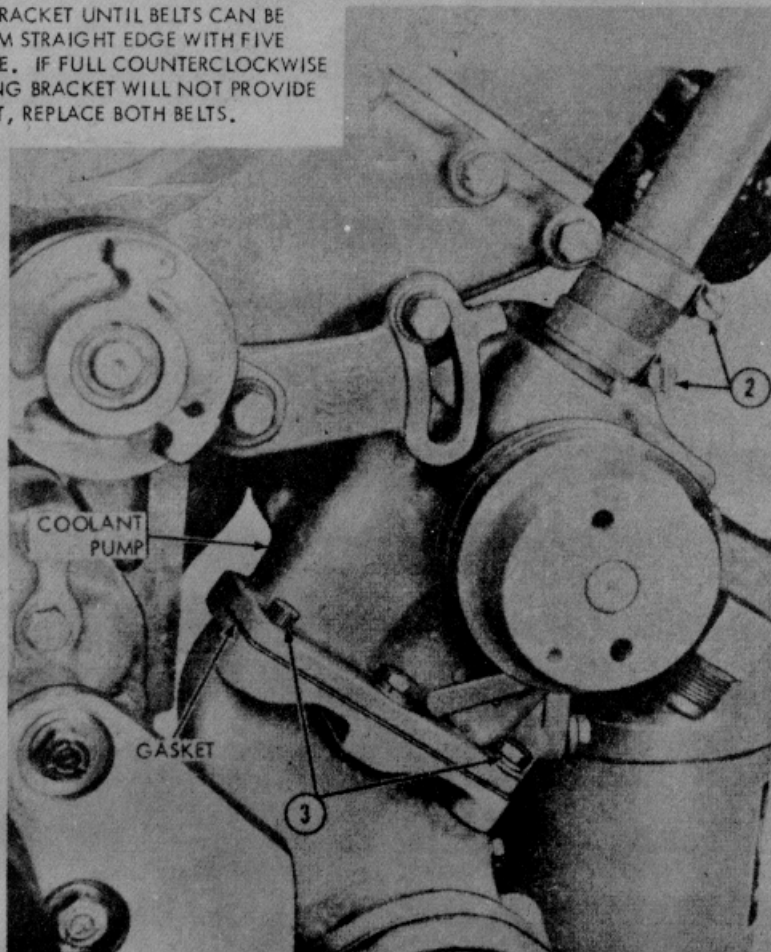
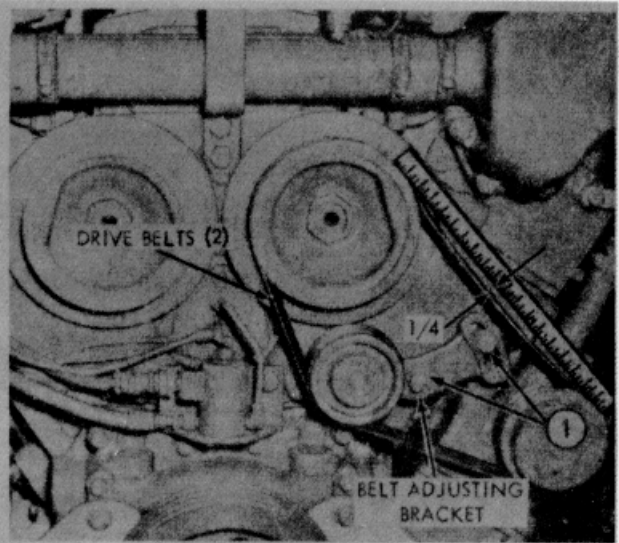

WE 11068

Figure 9-36. Removal/installation - engine coolant pump

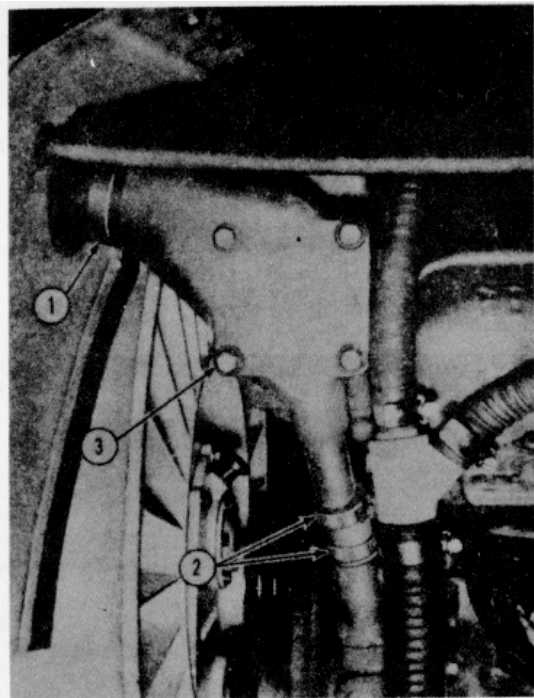

PRELIMINARY STEP  
DRAIN ENGINE COOLANT SYSTEM (TABLE 54).

REMOVAL

1. LOOSEN LARGE HOSE CLAMP.
2. LOOSEN SMALL HOSE CLAMPS -SLIDE HOSE UPWARD ON BYPASS TUBE.
3. SCREW (4), LOCK WASHER (4), FLAT WASHER (4), HOUSING, AND GASKET.

INSTALLATION

REVERSE REMOVAL SEQUENCE. INSTALL NEW GASKET AND THERMOSTAT.

LEGEND

1. GASKET
2. THERMOSTAT
3. THERMOSTAT HOUSING
4. BYPASS TUBE

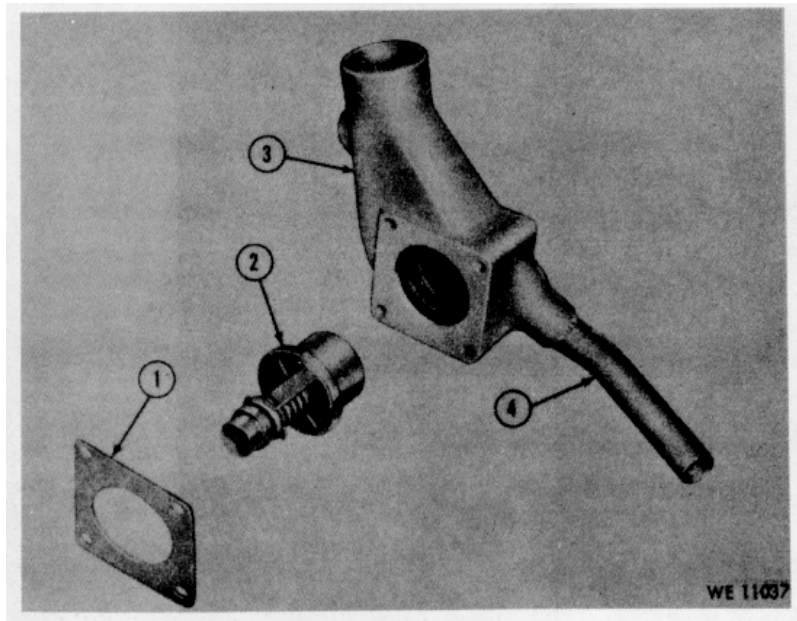

Figure 9-37. Removal/installation - thermostat housing and thermostat

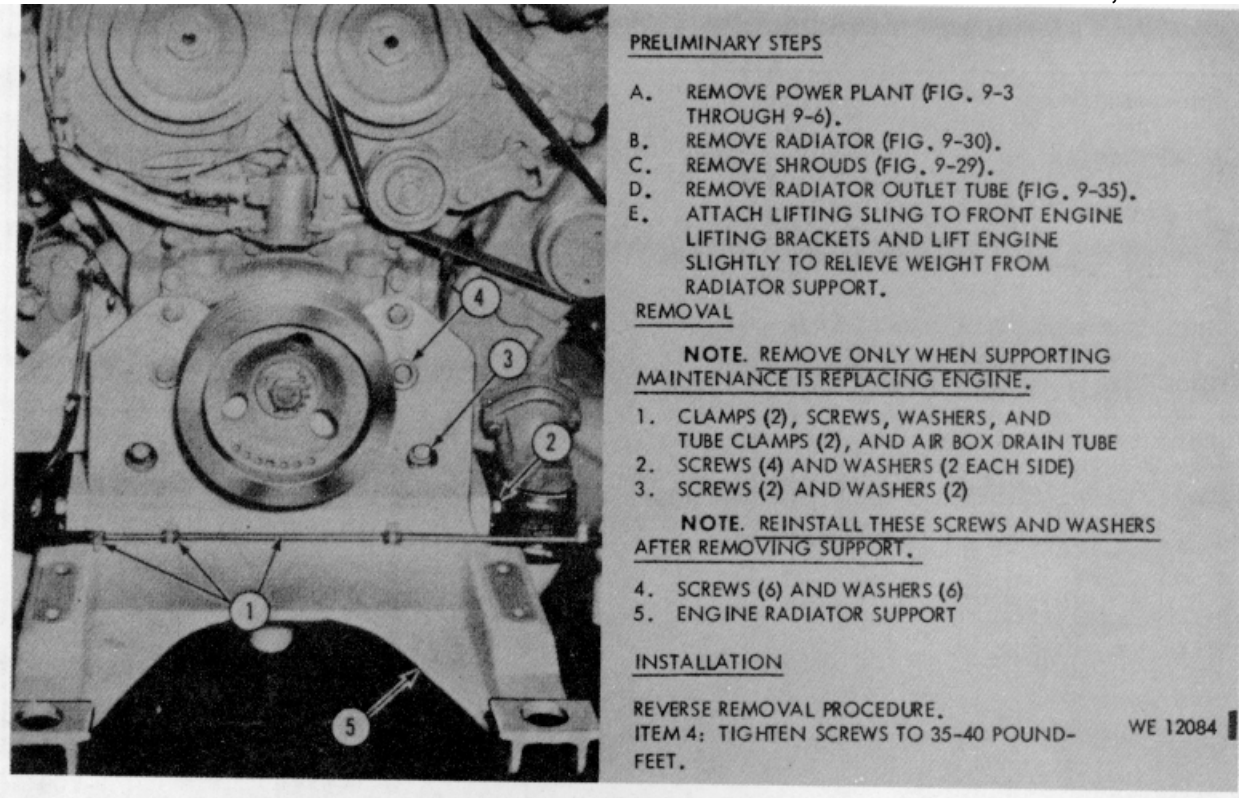

Figure 9-38. Removal/installation - engine radiator support

**Section 9-3. TRANSMISSION AND CONTROLS****9-11. General**

a. This section contains maintenance procedures for the transmission and transmission controls.

b. Refer to paragraph 8-9 to perform transmission pressure test

c. Refer to table 8-17 to perform in-vehicle stall test. To stall test transmission out-of-vehicle, refer to support maintenance.

d. Fuel shut-off controls are illustrated in figures 9-22 and 9-23.

e. Fixed fire extinguisher controls are illustrated in figures 9-140, 9-141, and 9-142.

*TABLE 9-4. TRANSMISSION AND CONTROLS*

ASSEMBLY OR COMPONENT	SERVICE	FIGURE REFERENCE		
		ADJUST	REPLACE	REPAIR
Internal Brake		9-39		
Oil Filter	9-40		9-40	
Oil Level Indicator	9-41			
Throttle Control Assembly and Linkage	9-43	9-44	9-45	9-45
Shift Control Assembly and Linkage	9-42	9-47	9-46	9-46
Brake Control Assembly and Linkage	9-43	9-48	9-49	9-50,51
Land Steer Control Assembly and Linkage	9-42	9-53	9-52	9-52
Water Steer Control Assembly and Linkage	9-42	9-55	9-54	9-54
Neutral Safety Switch		9-47		9-100
Water Steer Switch		9-55		9-100

PRELIMINARY STEP

REMOVE ENGINE ACCESS COVER (FIG. 9-3)

BRAKE CHECK AND ADJUSTMENT

1. REMOVE SNAP RING AND BRAKE LEVER FROM BRAKE APPLY SHAFT (SPLINED).
2. REMOVE 5 SCREWS, LOCK WASHERS, FLAT WASHERS AND TRANSMISSION INSPECTION COVER.
3. ADJUST RIGHT AND LEFT BRAKES SEPARATELY, INSTALL ADAPTER 5120-906-1051 ON BRAKE APPLY SHAFT WITH ½ INCH DRIVE SOCKET WRENCH EXTENSION AND STANDARD TORQUE WRENCH.
4. APPLY 100 POUND-FEET TORQUE TO BRAKE APPLY SHAFT (CLOCKWISE ON LEFT BRAKE, COUNTER-CLOCKWISE ON RIGHT BRAKE). NOTE POSITION OF INDICATOR RELATIVE TO INDEX DOT ON TRANSMISSION.
5. IF DOT IS BETWEEN "OFF" AND "APPLY", LOOSEN BRAKE. IF DOT IS ON "APPLY" OR BETWEEN "APPLY" AND "ADJ.", ADJUSTMENT IS SATISFACTORY. IF DOT IS ON "ADJ" OR BEYOND TIGHTEN BRAKE.

**NOTE.** LEFT AND RIGHT BRAKES MUST BE ADJUSTED EQUALLY.

6. TO ADJUST, LOOSEN LOCK NUT. TO LOOSEN BRAKE, TURN SCREW COUNTERCLOCKWISE (OUT). TO TIGHTEN BRAKE, TURN SCREW CLOCKWISE (IN). TIGHTEN LOCK NUT AFTER ADJUSTMENT,
7. RECHECK ADJUSTMENT WITH TORQUE WRENCH.
8. WHEN BOTH BRAKES HAVE BEEN ADJUSTED, APPLY BRAKES AND CHECK INDICATORS. INDICATOR READINGS SHOULD BE APPROXIMATELY SAME ON BOTH BRAKES.
9. INSTALL ITEMS REMOVED OR DISCONNECTED IN STEPS 1, 2, 3 AND 4.

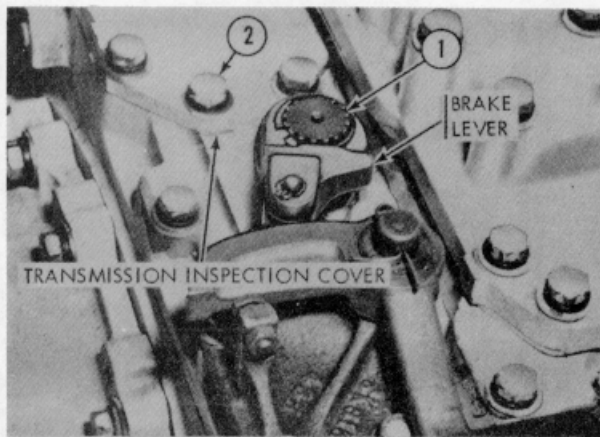

A. LEFT BRAKE CONTROL LEVER AND LINKAGE.

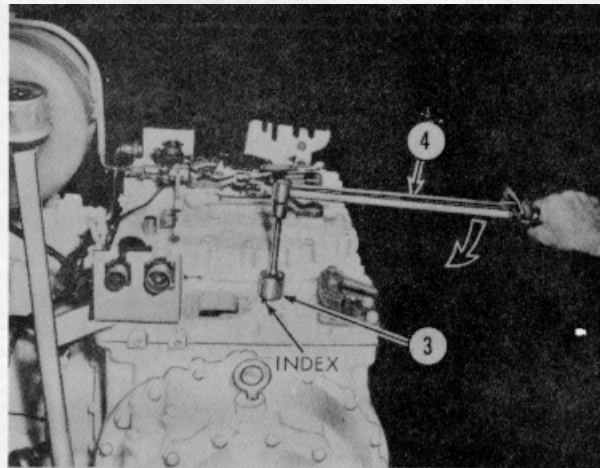

B. CHECKING BRAKE APPLY TORQUE LEFT SHOWN - RIGHT OPPOSITE.

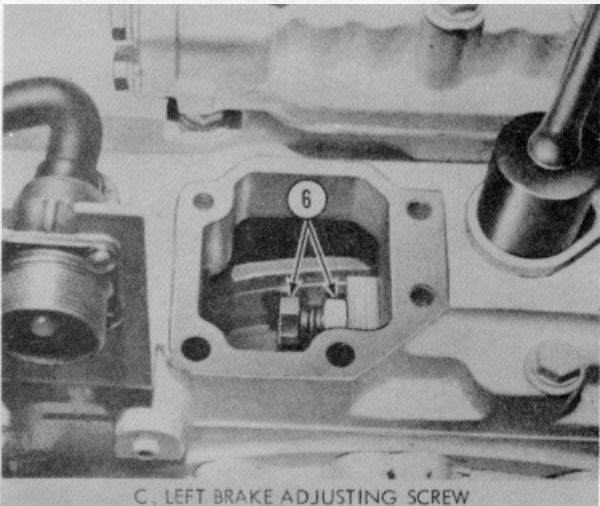

C. LEFT BRAKE ADJUSTING SCREW

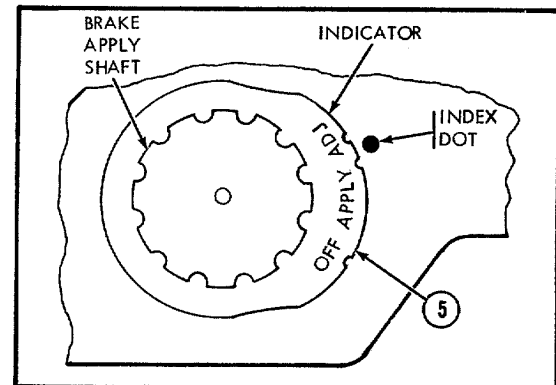

D. BRAKE INDICATOR - REFERENCE LEFT SHOWN - RIGHT OPPOSITE.

WE 66614

Figure 9-39. Transmission internal brake adjustment



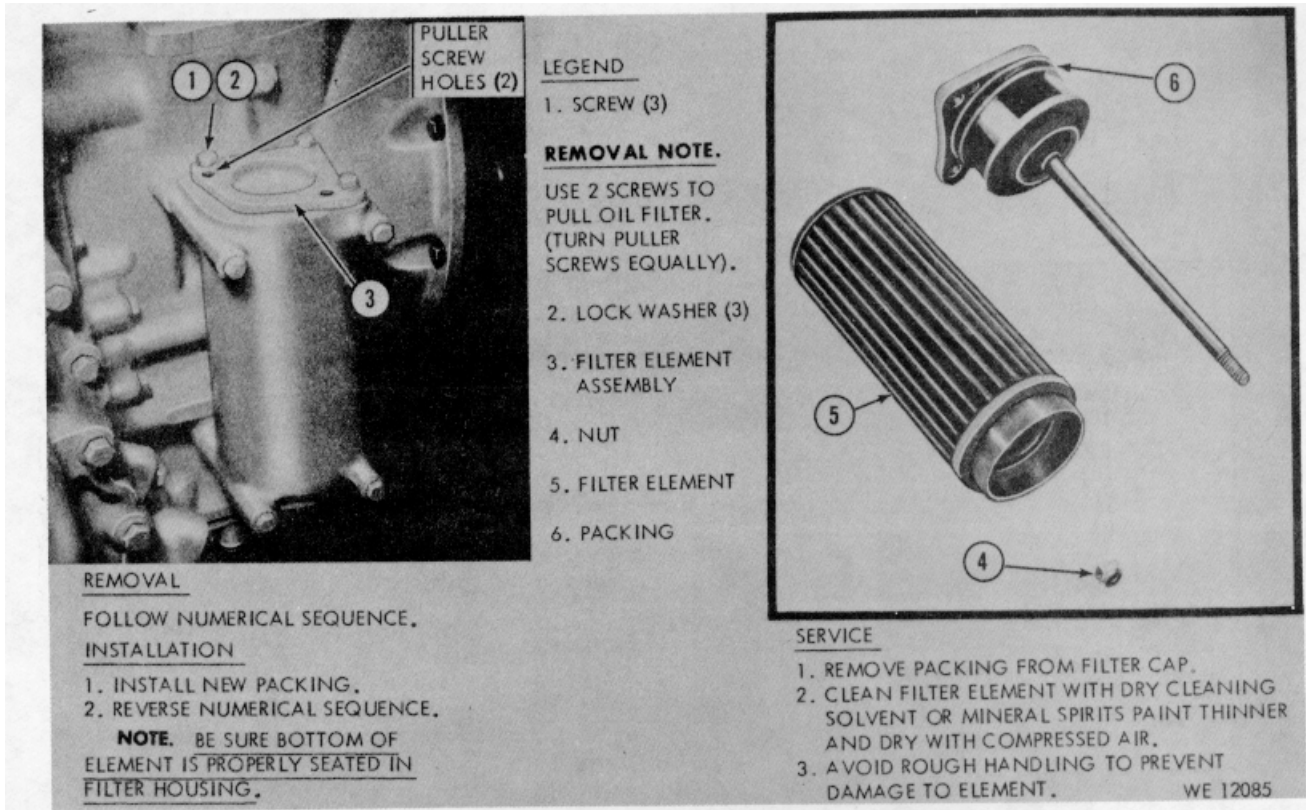

Figure 9-40. Removal/service/installation - transmission oil filter

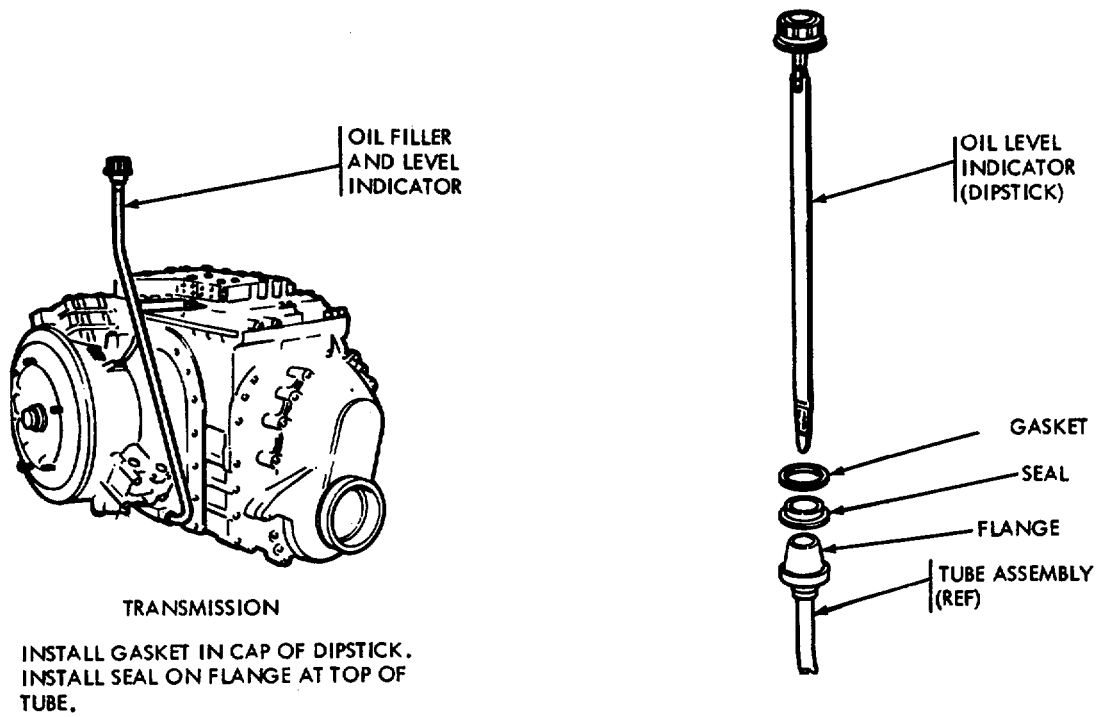
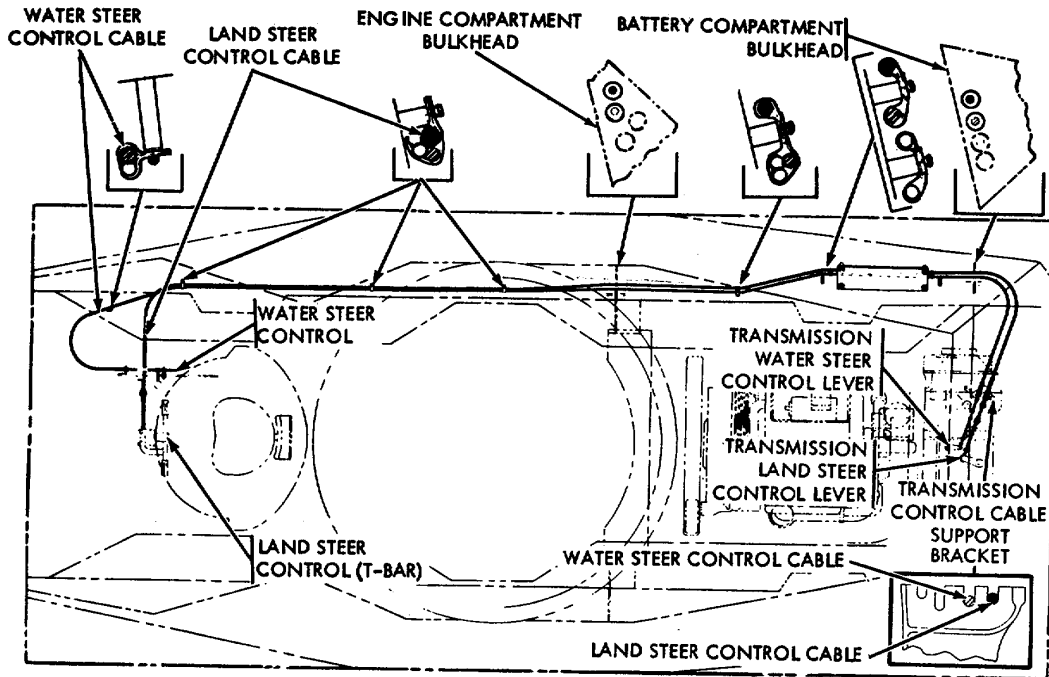
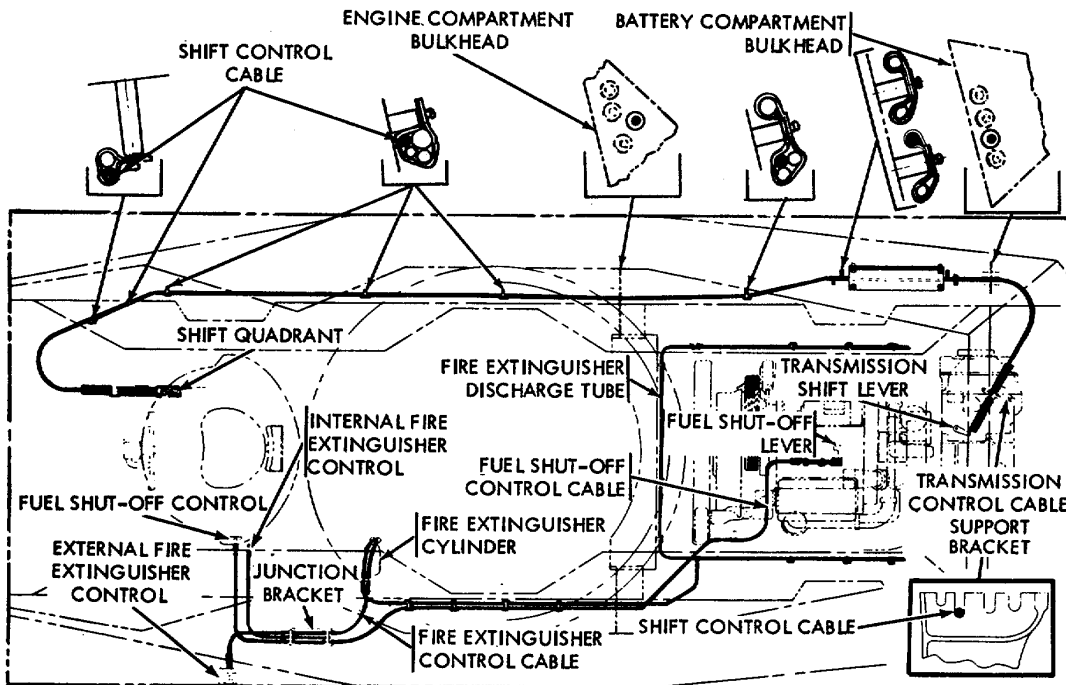

Figure 9-41. Installation - transmission dipstick, seal, and gasket



LAND AND WATER STEER CONTROLS  
(FIGURES 9-52 AND 9-54)



SHIFT, FUEL SHUT-OFF, AND FIXED FIRE EXTINGUISHER CONTROLS  
(FIGURES 9-46, 9-23, AND 9-141)

WE 12136

Figure 9-42. Land and water steer, shift, fuel shutoff, and fixed fire extinguisher controls - locational reference



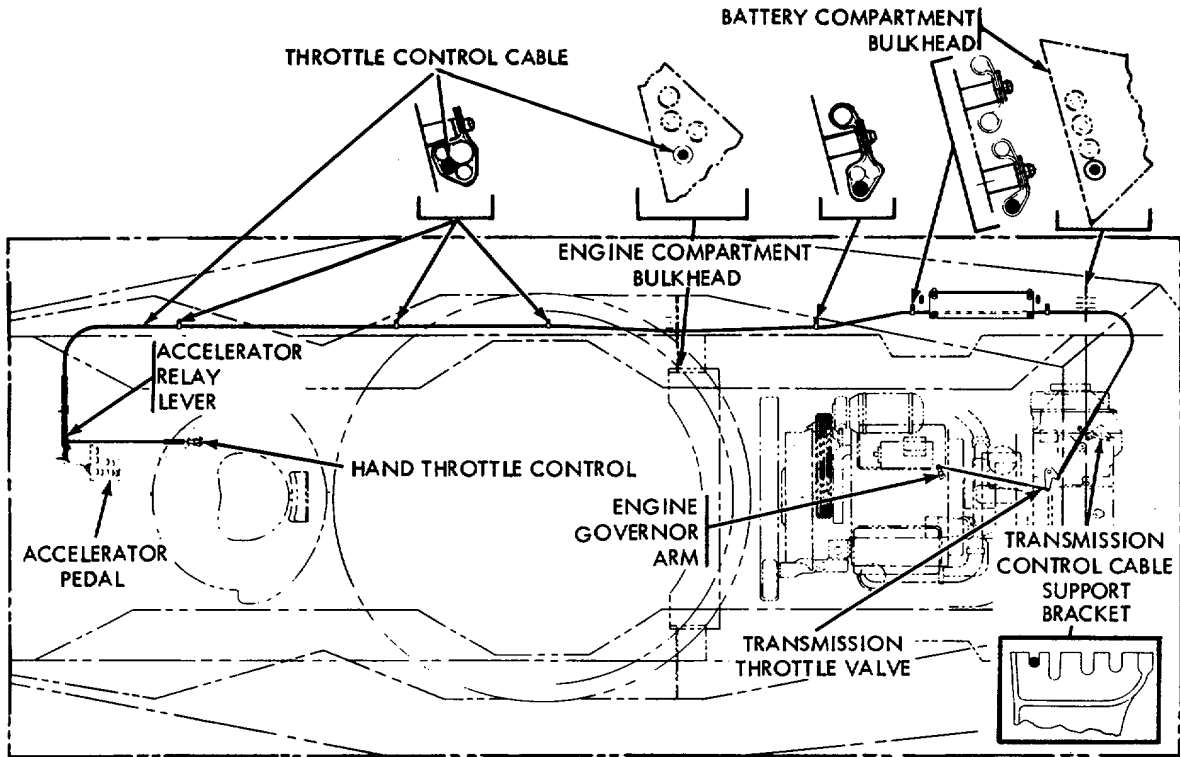

**THROTTLE CONTROL**  
(FIGURE 9-45)

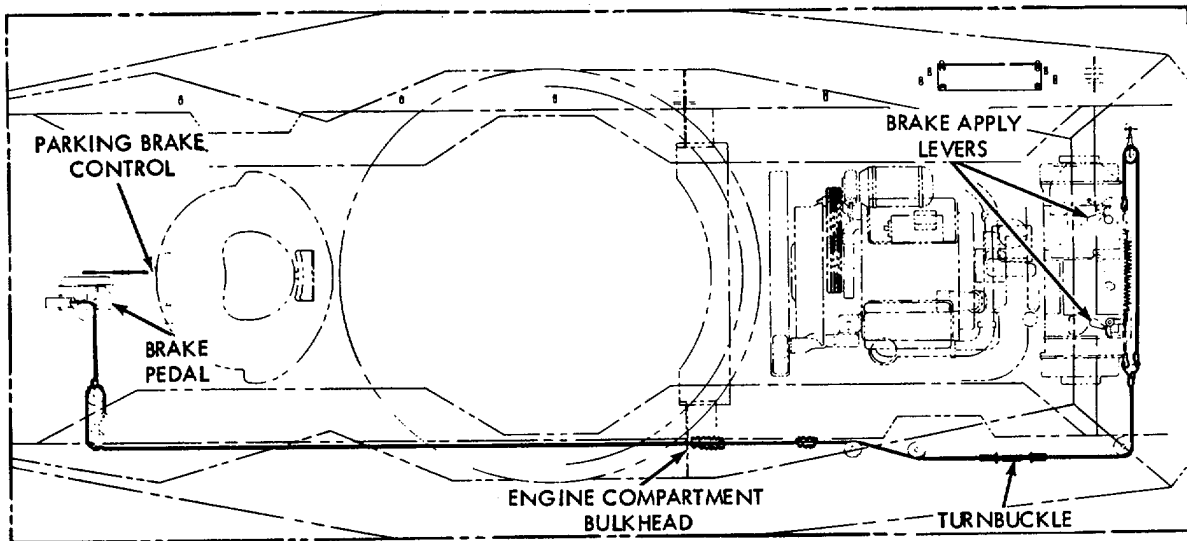

**BRAKE CONTROL**  
(FIGURES 9-49 AND 9-50)

Figure 9-43. Throttle and brake controls - locational reference

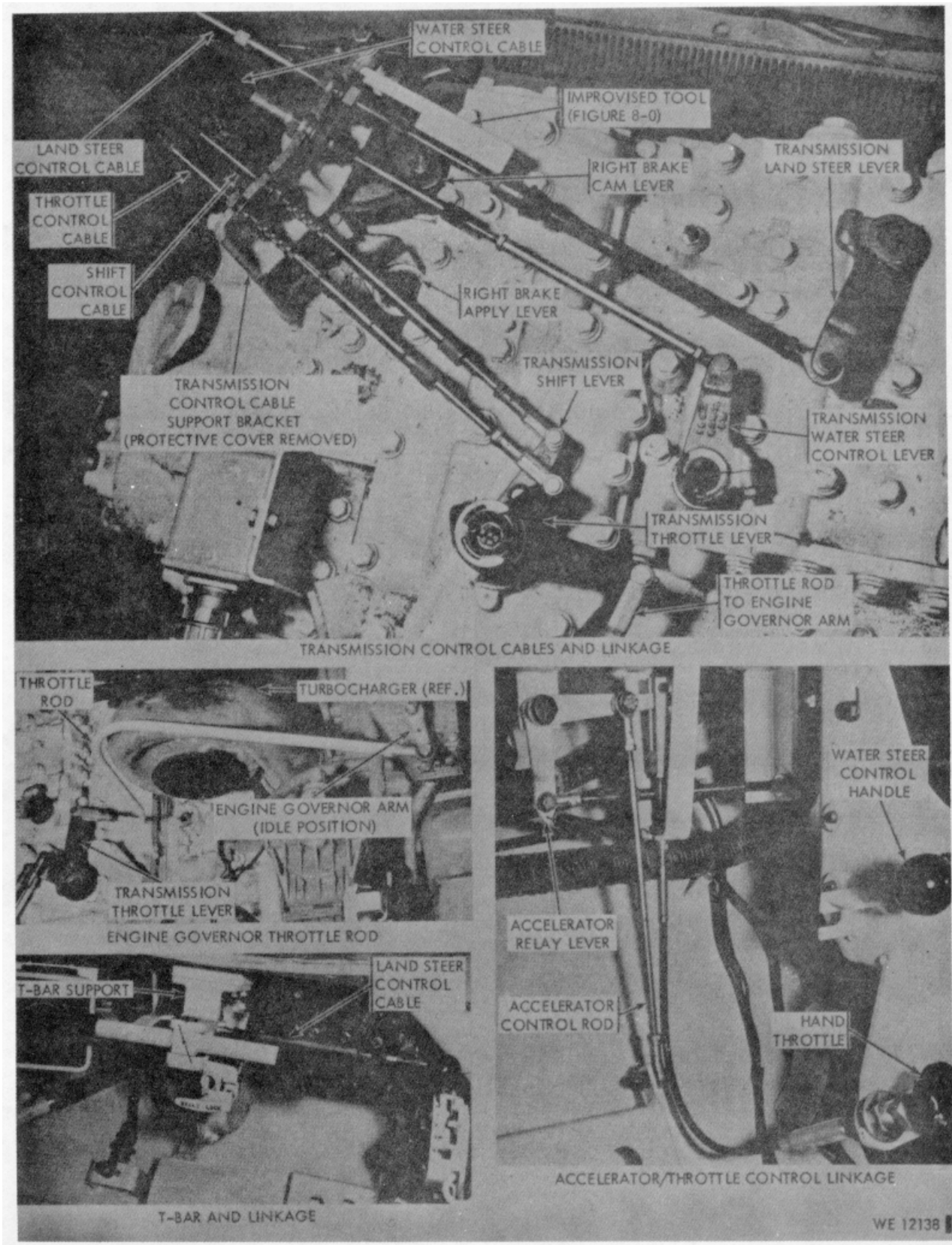
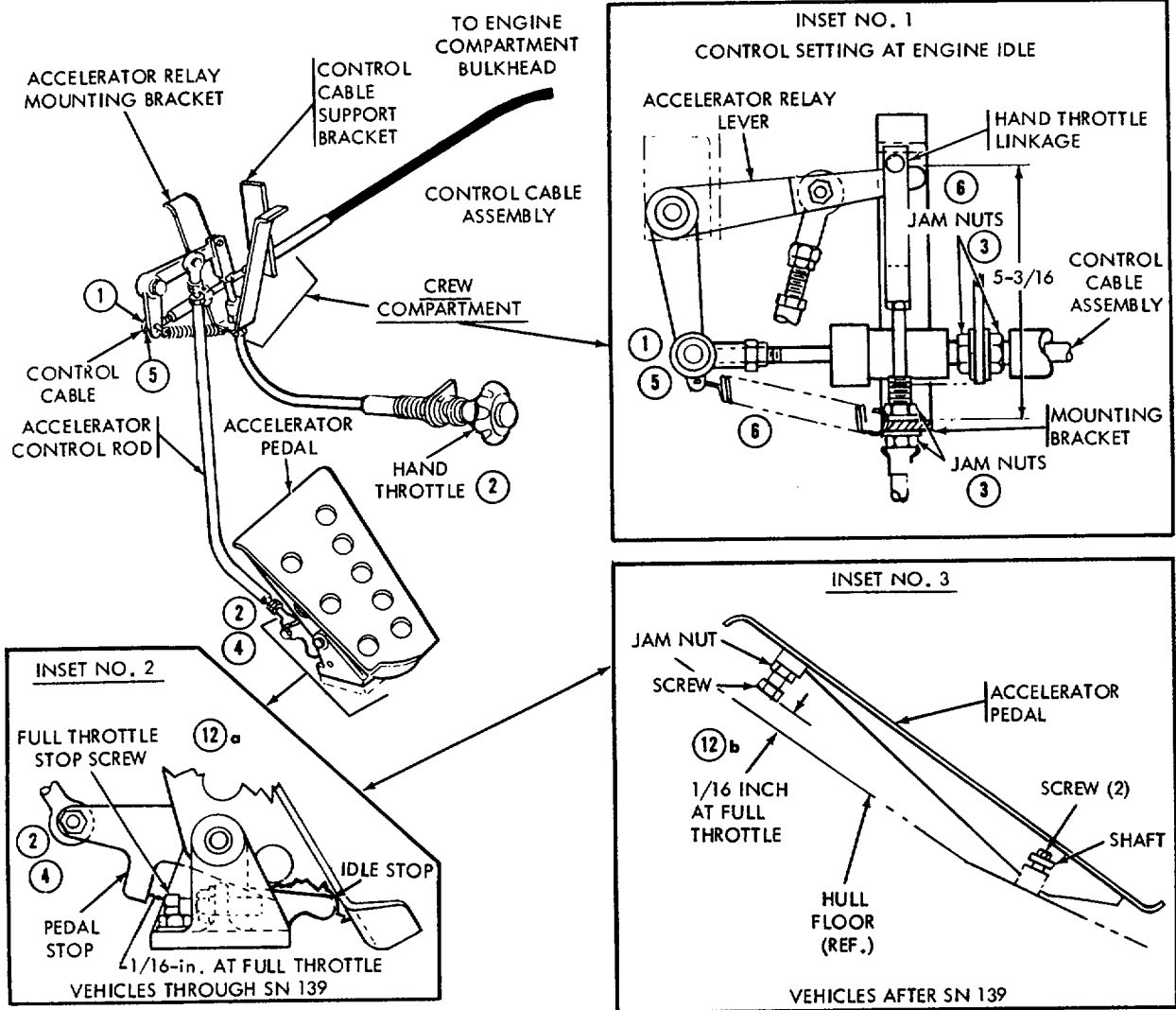

Figure 9-43.1. Control adjustment locational reference



**PRELIMINARY STEPS**

- A. REFER TO FIGURES 9-43 AND 9-43.1, LOCATIONAL REFERENCE.
- B. OPEN ENGINE EXHAUST GRILLES AND REMOVE ENGINE ACCESS COVER (FIG. 9-3, STEPS 3 THROUGH 5). PLACE WOODEN BLOCK APPROXIMATELY 2-1/2 INCHES THICK ON ENGINE STEP PLATE UNDER GRILLE SUPPORT. IF ACCESS TO BULKHEAD IS REQUIRED, ALSO REMOVE INTAKE GRILLE (FIG. 9-3, STEP 1).

**ACCELERATOR PEDAL AND HAND THROTTLE ADJUSTMENT**

1. DISCONNECT CONTROL CABLE AT ACCELERATOR RELAY LEVER ABOVE ACCELERATOR PEDAL (INSET No. 1).
2. DISCONNECT ACCELERATOR CONTROL ROD AT ACCELERATOR PEDAL, AND FULLY RELEASE HAND THROTTLE.
3. ADJUST HAND THROTTLE LINKAGE WITH JAM NUTS AT MOUNTING BRACKET TO OBTAIN 5-3/16 INCH DIMENSION SHOWN IN INSET NO. 1 (FROM MOUNTING BRACKET TO TOP OF ACCELERATOR RELAY LEVER).
4. ADJUST ACCELERATOR CONTROL ROD END BEARING FOR FREE FIT OF BOLT AT ACCELERATOR PEDAL WITH PEDAL AGAINST IDLE STOP. CONNECT ROD BEARING TO PEDAL.
5. CONNECT CONTROL CABLE TO ACCELERATOR RELAY LEVER.
6. ADJUST CONTROL CABLE WITH JAM NUTS AT MOUNTING BRACKET TO OBTAIN FREE PIN FIT AT CLEVIS ON BOTTOM OF ACCELERATOR RELAY LEVER (INSET NO. 1).

WE 12139

Figure 9-44. Accelerator/throttle control and linkage adjustment (1 of 2)

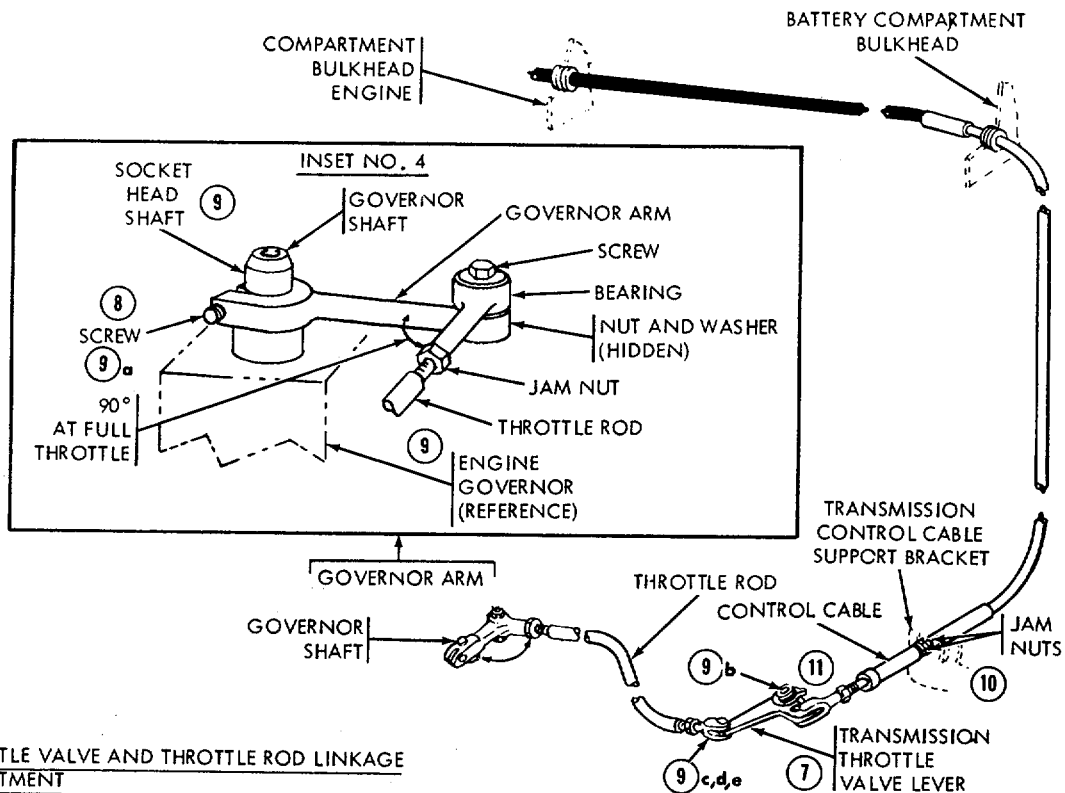

#### THROTTLE VALVE AND THROTTLE ROD LINKAGE ADJUSTMENT

7. ON TRANSMISSION, DISCONNECT CONTROL CABLE AND THROTTLE ROD AT THROTTLE VALVE LEVER.
  8. LOOSEN ENGINE GOVERNOR ARM SCREW AT GOVERNOR SHAFT (INSERT No. 4).
  9. TURN GOVERNOR SHAFT CLOCKWISE WITH SOCKET HEAD SCREW KEY TO FULL THROTTLE POSITION. WITH THROTTLE ROD HELD IN ITS NORMAL POSITION SET GOVERNOR ARM AND THROTTLE ROD AT 90°.
    - a. TIGHTEN ENGINE GOVERNOR ARM SCREW TO GOVERNOR SHAFT.
    - b. AT TRANSMISSION, ROTATE THROTTLE VALVE LEVER UNTIL FULL THROTTLE STOP IN TRANSMISSION IS REACHED.
- CAUTION: DO NOT ROTATE LEVER FURTHER BY WINDING TORSION SPRING.
- c. WITH ENGINE GOVERNOR ARM ROTATED TO FULL THROTTLE POSITION, ADJUST THROTTLE ROD CLEVIS FOR FREE PIN FIT AT TRANSMISSION THROTTLE VALVE LEVER. DO NOT INSTALL CLEVIS PIN.
  - d. LENGTHEN THROTTLE ROD BY TURNING CLEVIS ONE FULL TURN COUNTERCLOCKWISE. THIS INSURES THAT TRANSMISSION REACHES FULL THROTTLE POSITION BEFORE ENGINE GOVERNOR.
  - e. INSTALL CLEVIS PIN AND COTTER PIN AT TRANSMISSION THROTTLE VALVE LEVER, AND TIGHTEN CLEVIS JAM NUT.

#### ACCELERATOR CONTROL CABLE ADJUSTMENT

10. SECURE CONTROL CABLE HOUSING TO TRANSMISSION CONTROL CABLE SUPPORT BRACKET WITH JAM NUTS. PULL CLEVIS TO REMOVE ALL SLACK FROM CABLE.
11. WITH HAND THROTTLE CLOSED AND TRANSMISSION THROTTLE VALVE LEVER AT IDLE POSITION, ADJUST CLEVIS TO PROVIDE FREE PIN FIT AT LEVER. TIGHTEN CLEVIS JAM NUT.
12. DEPRESS ACCELERATOR PEDAL TO GIVE FULL THROTTLE POSITION AT ENGINE GOVERNOR ARM. ADJUST PEDAL FULL THROTTLE STOP SCREW:
  - a. VEHICLES THROUGH SN 139 - WITH PEDAL IN FULL THROTTLE POSITION ADJUST STOP SCREW FOR 1/16 INCH CLEARANCE FROM PEDAL STOP (INSET NO. 2). TIGHTEN JAM NUT.
  - b. VEHICLES AFTER SN139 - WITH PEDAL IN FULL THROTTLE POSITION ADJUST STOP SCREW FOR 1/16 INCH CLEARANCE FROM HULL FLOOR (INSET NO. 3). TIGHTEN JAM NUT.

NOTE. ROD END BEARINGS AND/OR CLEVISES INSTALLED ON CONTROL CABLE ASSEMBLIES MUST HAVE AT LEAST 3/8 INCH THREAD ENGAGEMENT FOR STRENGTH AND SAFETY, AND MUST BE LOCKED IN POSITION WITH JAM NUTS.

WE 12140

Figure 9-44.1. Accelerator/throttle control and linkage adjustment (2 of 2)

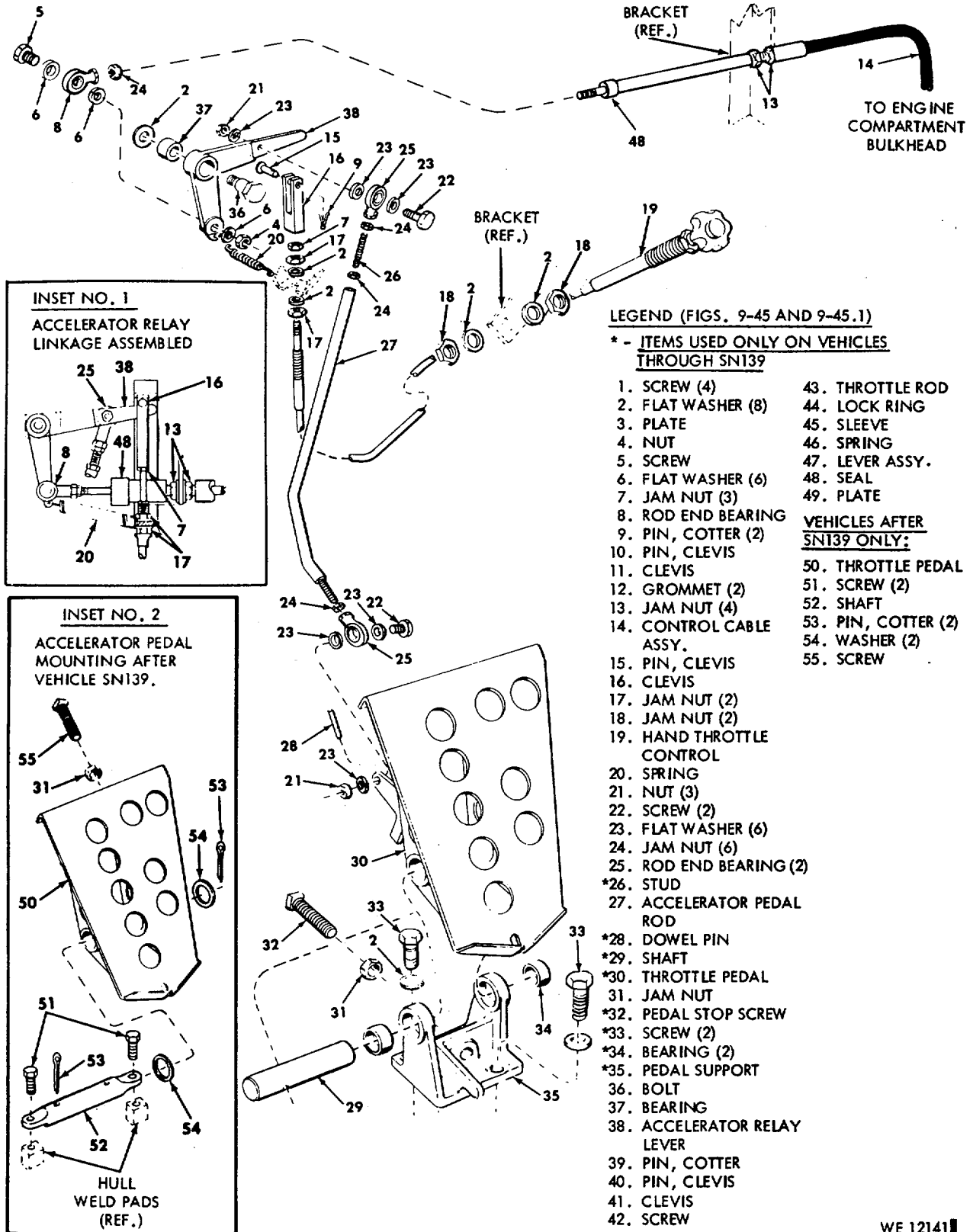
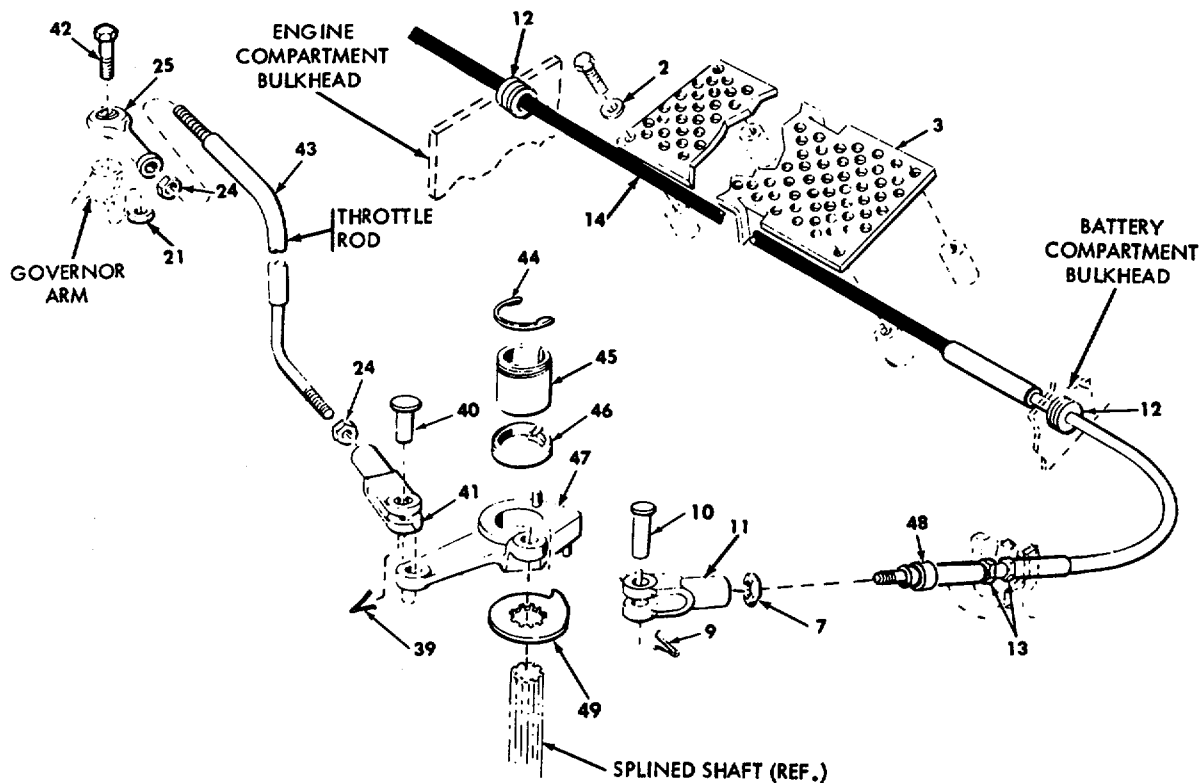

Figure 9-45. Disassembly/assembly - accelerator and throttle control assembly and linkage (1 of 2)



#### PRELIMINARY STEPS

- A. OPEN ENGINE EXHAUST GRILLES AND REMOVE ENGINE ACCESS COVER (FIG. 9-3, STEP 3 THROUGH 5). PLACE WOODEN BLOCK APPROXIMATELY 2-1/2 INCHES THICK ON ENGINE STEP PLATE UNDER GRILLE SUPPORT.
- B. REMOVE VEHICLE BATTERIES (FIG. 9-97).
- C. REMOVE 2 SCREWS, WASHERS, AND PROTECTIVE PLATE FROM TRANSMISSION CONTROL CABLE SUPPORT (FIG. 9-4, ITEM 12).
- D. REVIEW CONTROL CABLE HANDLING PRECAUTIONS (TABLE 9-9.1) AND CONTROL CABLE LOCATIONAL REFERENCE (FIGS. 9-43 AND 9-43.1).

#### DISASSEMBLY/ASSEMBLY

REPLACE UNSERVICEABLE PARTS AS REQUIRED. IF CONTROL CABLE MUST BE REMOVED, PROCEED AS FOLLOWS:

#### REMOVAL

1. REMOVE FOUR SCREWS (1), FLAT WASHERS (2), AND PROTECTIVE PLATE (3).
2. REMOVE NUT (4), SCREW (5), THREE FLAT WASHERS (6), TO DISCONNECT ROD END BEARING (8) FROM ACCELERATOR RELAY LEVER (38).
3. REMOVE COTTER PIN (9) AND CLEVIS PIN (10) AT TRANSMISSION THROTTLE LEVER (47).
4. LOOSEN JAM NUTS (7), REMOVE CLEVIS (11), AND BEARING (8) FROM ENDS OF CONTROL CABLE ASSEMBLY (14).
5. REMOVE JAM NUTS (13) FROM BOTH ENDS OF CABLE.
6. REMOVE CONTROL CABLE RETAINING STRAPS (FIG. 9-43).

7. REMOVE TWO GROMMETS (12) FROM ENGINE AND BATTERY COMPARTMENT BULKHEADS.
8. REMOVE CABLE FROM ENGINE COMPARTMENT. BE SURE TO HOLD CABLE BY OUTER HOUSING ONLY, NOT BY INNER CABLE.

#### INSTALLATION

**NOTE.** INSPECT SEALS (48) AND REPLACE IF DETERIORATED.

9. INSTALL CABLE ASSEMBLY THROUGH VEHICLE FROM ENGINE COMPARTMENT.
10. INSTALL JAM NUTS (13), PLACE CONTROL CABLE IN MOUNTING BRACKETS, AND LIGHTLY TIGHTEN JAM NUTS. INSTALL GROMMETS (12) AND RETAINING STRAPS.
11. ATTACH JAM NUTS (7) AND BEARINGS (8) TO CONTROL CABLE ASSEMBLY AND ATTACH TO ACCELERATOR RELAY LEVER WITH SCREW (5), WASHERS (6), AND NUT (4).
12. ATTACH JAM NUT (7) AND CLEVIS (9) TO OTHER END OF CONTROL CABLE ASSEMBLY (14). CONNECT CLEVIS TO TRANSMISSION THROTTLE LEVER WITH PIN (10) AND COTTER PIN (9).
13. REFER TO FIGURES 9-44 AND 9-44.1 FOR ACCELERATOR/THROTTLE CONTROL AND LINKAGE ADJUSTMENT.

**NOTE.** ROD END BEARINGS AND/OR CLEVISES INSTALLED ON CONTROL CABLE ASSEMBLIES MUST HAVE AT LEAST 3/8 INCH THREAD ENGAGEMENT FOR STRENGTH AND SAFETY, AND MUST BE LOCKED IN POSITION WITH JAM NUTS.

WE 12142

Figure 9-45.1. Disassembly/assembly - accelerator and throttle control assembly and linkage (2of2)

Table 9-4.1 - Deleted

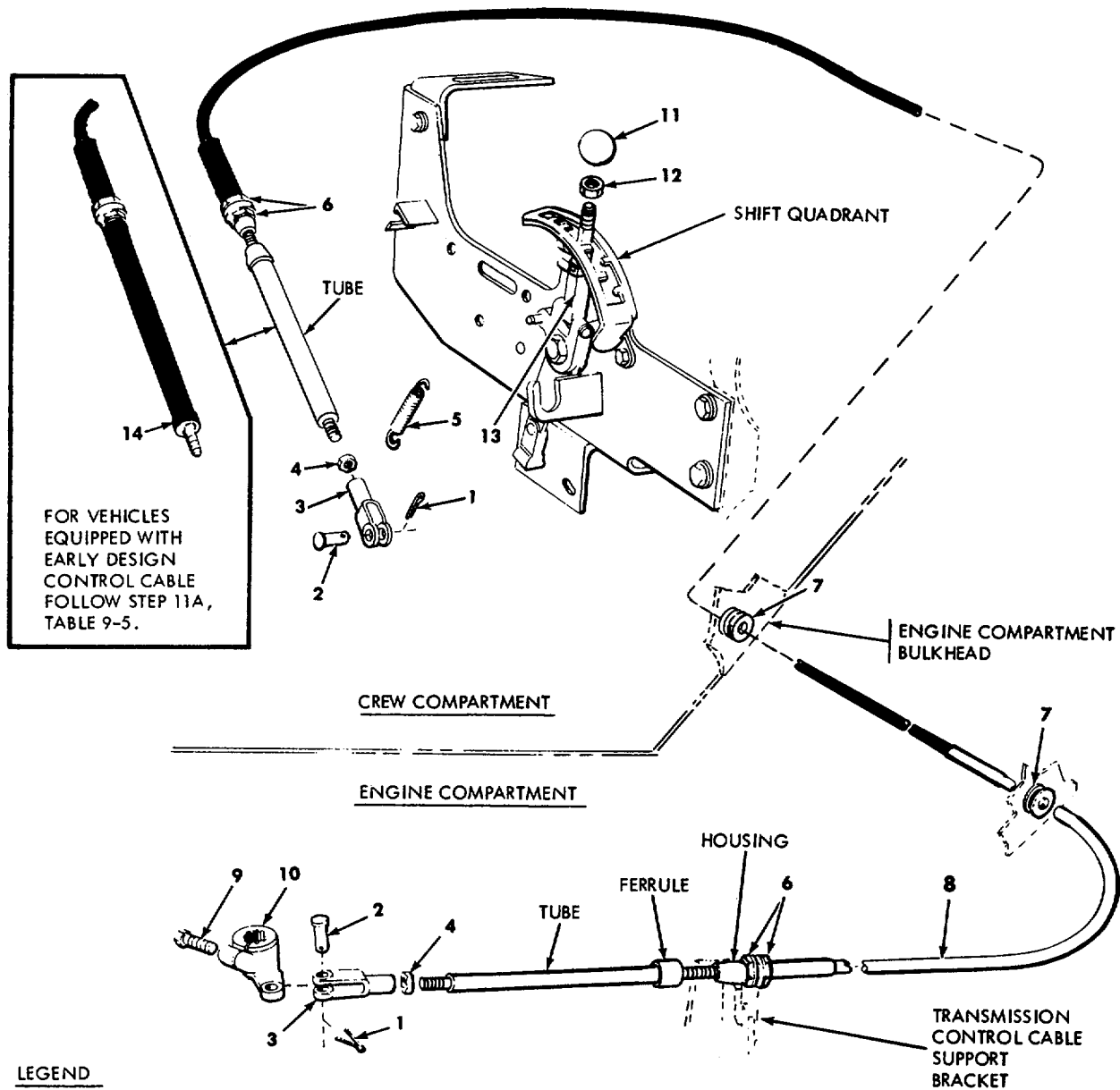

**LEGEND**

- |                    |                              |                          |
|--------------------|------------------------------|--------------------------|
| 1. PIN, COTTER (2) | 6. JAM NUTS (4)              | 11. KNOB ASSEMBLY        |
| 2. PIN, CLEVIS (2) | 7. GROMMET (2)               | 12. NUT                  |
| 3. CLEVIS (2)      | 8. CONTROL ASSEMBLY          | 13. SHIFT LEVER ASSEMBLY |
| 4. JAM NUT (2)     | 9. SCREW                     | 14. SEAL (2)             |
| 5. SPRING          | 10. TRANSMISSION SHIFT LEVER |                          |

REFER TO TABLE 9-5 - REMOVAL/INSTALLATION/REPAIR - TRANSMISSION SHIFT CONTROL AND LINKAGE.

REPLACE UNSERVICEABLE PARTS AS REQUIRED.

**NOTE.** ROD END BEARINGS AND/OR CLEVISES INSTALLED ON CONTROL CABLE ASSEMBLIES MUST HAVE AT LEAST 3/8 INCH THREAD ENGAGEMENT FOR STRENGTH AND SAFETY, AND MUST BE LOCKED IN POSITION WITH JAM NUTS.

WE 12143 ■

Figure 9-46. Removal/installation/repair - transmission shift control assembly and linkage

TABLE 9-5. REMOVAL/INSTALLATION - TRANSMISSION SHIFT CONTROL  
ASSEMBLY AND LINKAGE (FIGURE 9-46)

#### PRELIMINARY STEPS

- A. Open engine exhaust grilles and remove engine access cover (fig. 9-3, steps 3 through 5). Place wooden block approximately 2-1/2 inches thick on engine step plate under grille support. If access to bulkhead is required, also remove intake grille (fig. 9-3, step 1).
- B. Remove vehicle batteries (fig. 9-97).
- C. Remove four screws, three washers, and protective plate from battery compartment (fig. 9-45. 1, item 3).
- D. Remove two screws, washers, and protective plate from control cable support at transmission (fig. 9-4, item 12).
- E. Review control cable handling precautions, table 9-9. 1.

#### REMOVAL (Refer to figure 9-46 for item reference numbers.)

1. Remove cotter pin (1) and clevis pin (2) from clevis (3) at driver's shift lever (13) and transmission shift lever (10).
2. Loosen jam nut and remove clevis (3) and jam nut (4) from both ends of control. Loosen and remove control assembly jam nuts (6) at mounting bracket in driver's compartment and control support at the transmission. Remove two grommets (7) and retaining straps along right side of hull (fig. 9-42).
3. Remove control out through engine compartment. Handle control assembly by outer casing and not by inner race rod.

#### INSTALLATION

**NOTE.** Inspect seals and replace if deteriorated.

4. Install control cable through the vehicle from engine compartment.
5. Place jam nuts (4) and clevis (3) on control rod ends. Do not twist center race rod.
6. Install grommet (7) and retaining straps (fig. 9-42).
7. Install jam nuts (6) and position control assembly in mounting brackets. Do not tighten.
8. Install jam nut (4) and clevis (3) with approximately 3/8-inch thread engagement on both ends of the control assembly.
9. Attach clevis to driver's shift lever (13) with clevis pin (2) and cotter pin (1).
10. Position driver's shift lever in "N" (Neutral) position and install 1/8-inch dia. pin in pad provided (fig. 9-47). Place transmission shift lever (10) in "N" position.
11. Late design control cable - Adjust control assembly, using jam nuts (6) at mounting bracket in driver's compartment, to obtain measurement of  $1/8 + 1/16$  inch from control cable tube to clevis jam nut (fig. 9-47).
- 11A. Early design control cable - Adjust control assembly, using jam nuts (6) at mounting bracket in driver's compartment, to obtain a measurement of 2 inches from control assembly wiper-seal to threads on the race rod. (See inset, fig. 9-47).
12. Adjust control assembly jam nuts at transmission control support bracket to provide a free pin fit at transmission shift lever.
13. Remove 1/8-inch dia. pin from quadrant. Clevis pin at transmission lever should fit freely in all shift positions. Install clevis pin (2) and cotter pin (1).



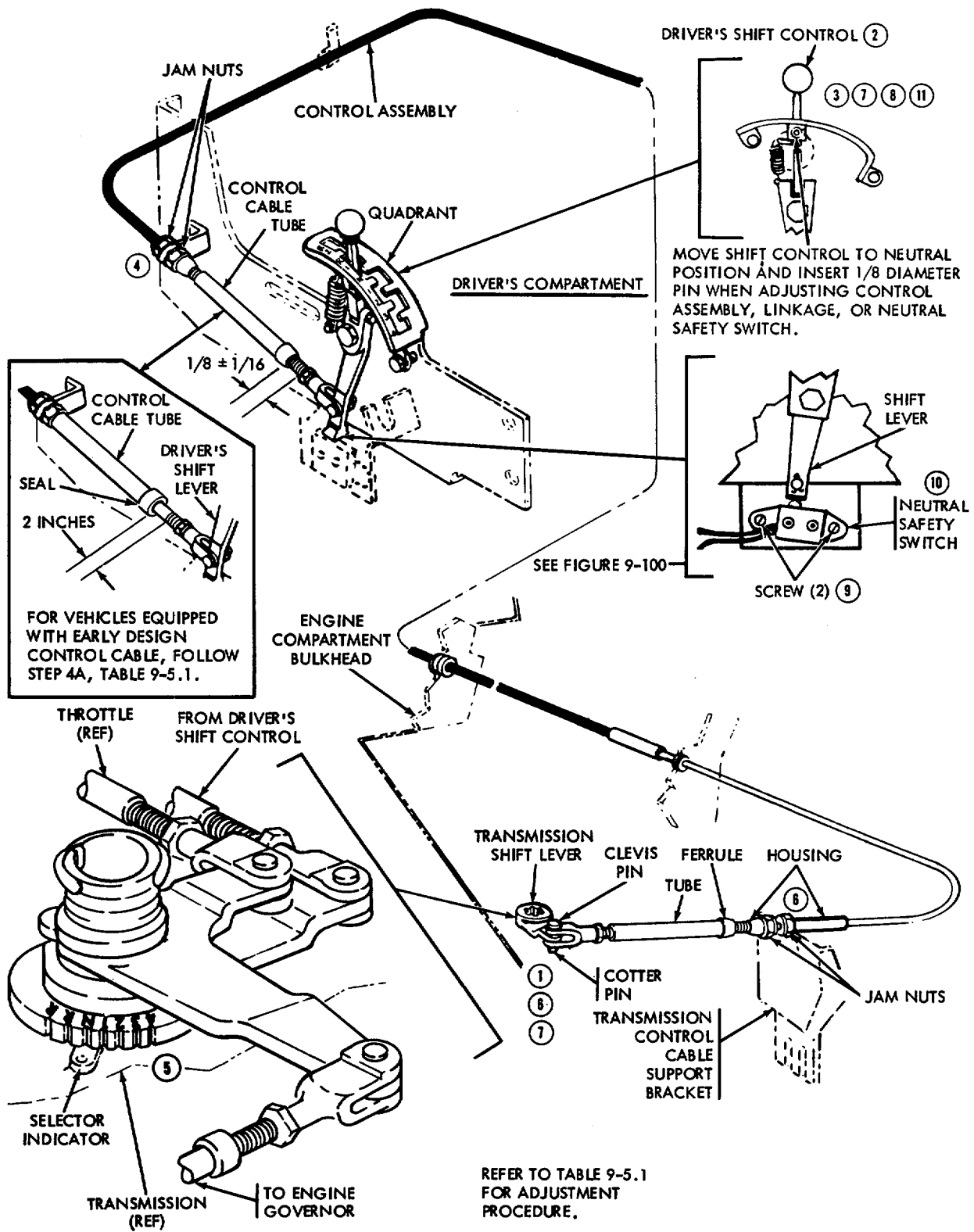

WE 12144

Figure 9-47. Transmission shift control and linkage adjustment

TABLE 9-5.1. TRANSMISSION SHIFT CONTROL AND LINKAGE ADJUSTMENT (FIGURE 9-47)

**PRELIMINARY STEPS**

- A. Open engine exhaust grilles and remove engine access cover (Figure 9-3, step 3 through 5). Place wooden block approximately 2-1/2 inches thick on engine step plate under grille support. If access to bulkhead is required, also remove intake grille (Fig. 9-3, step 1).
- B. Remove vehicle batteries (Fig. 9-97).
- C. Remove two screws, washers and protective plate from transmission control cable support (Figure 9-4, item 12).
- D. Review control cable handling precautions, table 9-9. 1.

**TRANSMISSION SHIFT CONTROL ADJUSTMENT**

1. At transmission, remove cotter pin and clevis pin and disconnect shift linkage from shift lever.
2. Move driver's shift control to any drive range then back to "N" (NEUTRAL) position.
3. Align hole in driver's shift control with hole in pad on shift quadrant. Insert a 1/8-inch dia. pin in hole provided to retain shift lever in "N" position (see Figure 9-47).
4. Adjust late design control assembly by using jam nuts at mounting bracket in driver's compartment, to obtain measurement of 1/8 41/16 inch from control cable tube to clevis jam nut.
- 4A. Adjust early design control assembly by using jam nuts at mounting bracket in driver's compartment to obtain a measurement of 2 inches from control assembly wiper-seal to threads on race rod.
5. Move shift lever on transmission (by hand) to "N" (NEUTRAL) position as indicated by selector indicator on transmission.
6. At transmission control support bracket, adjust control assembly jam nuts to provide a free pin fit at transmission shift lever.
7. Remove 1/8-inch dia. pin from quadrant, operate driver's shift control in all positions and check for proper synchronization between driver's and transmission shift levers (clevis pin at transmission shift lever should fit freely in all shift positions). (Replace cotter pin).

**NEUTRAL SAFETY SWITCH ADJUSTMENT**

8. Perform step 3,
9. Loosen two neutral safety switch mounting screws.
10. Position switch so that roller is in center of heel of lever and is depressed sufficiently to actuate switch (switch closed). Tighten mounting screws.
11. Remove 1/8-inch dia. pin, set parking brake and start engine to check proper operation of switch. Attempt to start engine with driver's shift control in other than "N" (NEUTRAL) position. If switch is adjusted correctly the engine starter will not activate.

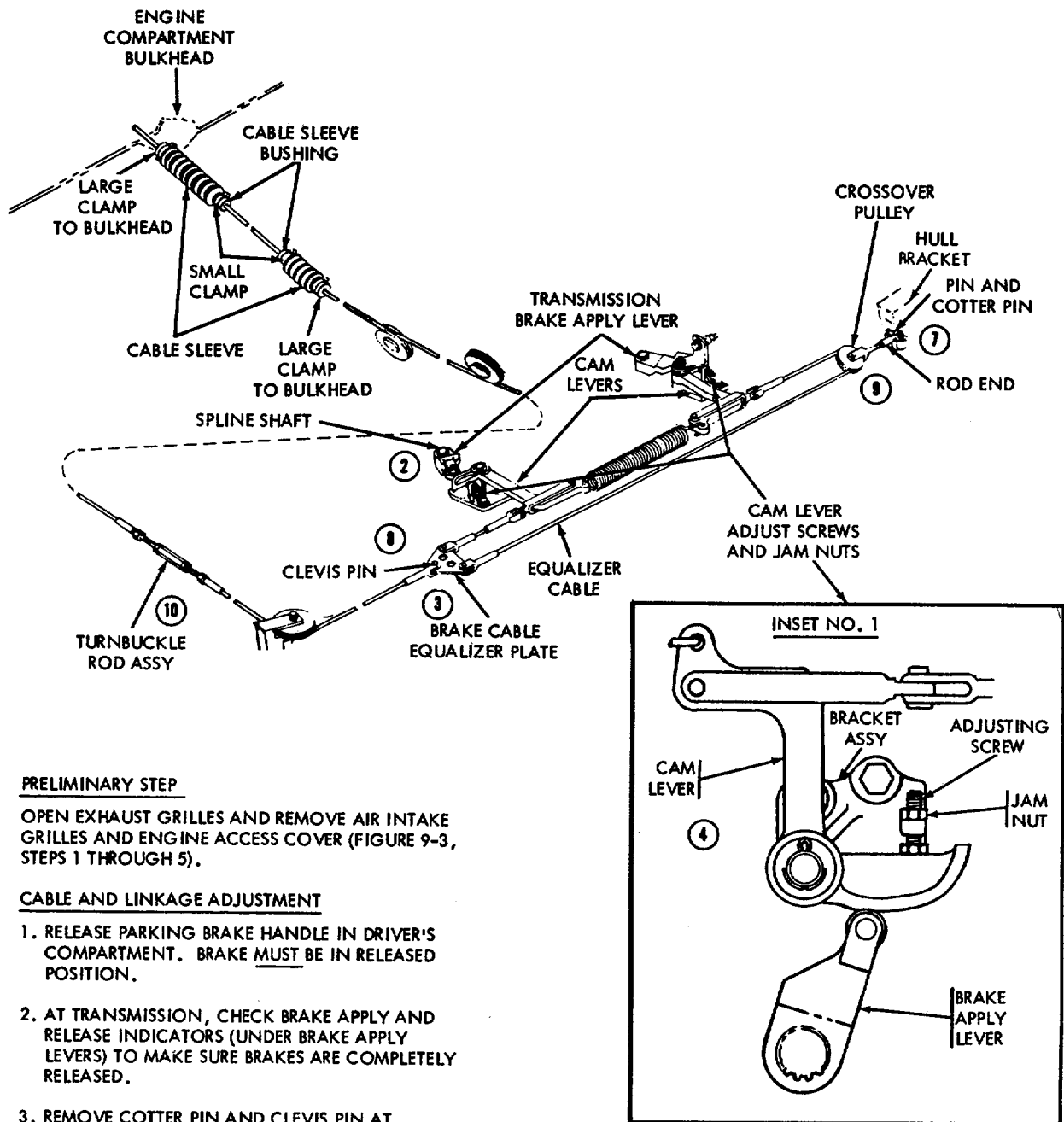

#### PRELIMINARY STEP

OPEN EXHAUST GRILLES AND REMOVE AIR INTAKE GRILLES AND ENGINE ACCESS COVER (FIGURE 9-3, STEPS 1 THROUGH 5).

#### CABLE AND LINKAGE ADJUSTMENT

1. RELEASE PARKING BRAKE HANDLE IN DRIVER'S COMPARTMENT. BRAKE MUST BE IN RELEASED POSITION.
2. AT TRANSMISSION, CHECK BRAKE APPLY AND RELEASE INDICATORS (UNDER BRAKE APPLY LEVERS) TO MAKE SURE BRAKES ARE COMPLETELY RELEASED.
3. REMOVE COTTER PIN AND CLEVIS PIN AT EQUALIZER PLATE TO DISENGAGE BRAKE CABLE.
4. LOOSEN JAM NUTS AND TURN ADJUSTING SCREWS ON EACH BRACKET UNTIL CAM LEVERS ARE FIRMLY SEATED AGAINST BRAKE APPLY LEVERS (INSET NO. 1).

**CAUTION:** THIS ADJUSTMENT MUST NOT ROTATE BRAKE APPLY LEVERS.

WE 12145

Figure 9-48. Brake control and linkage adjustment (1 of 2)

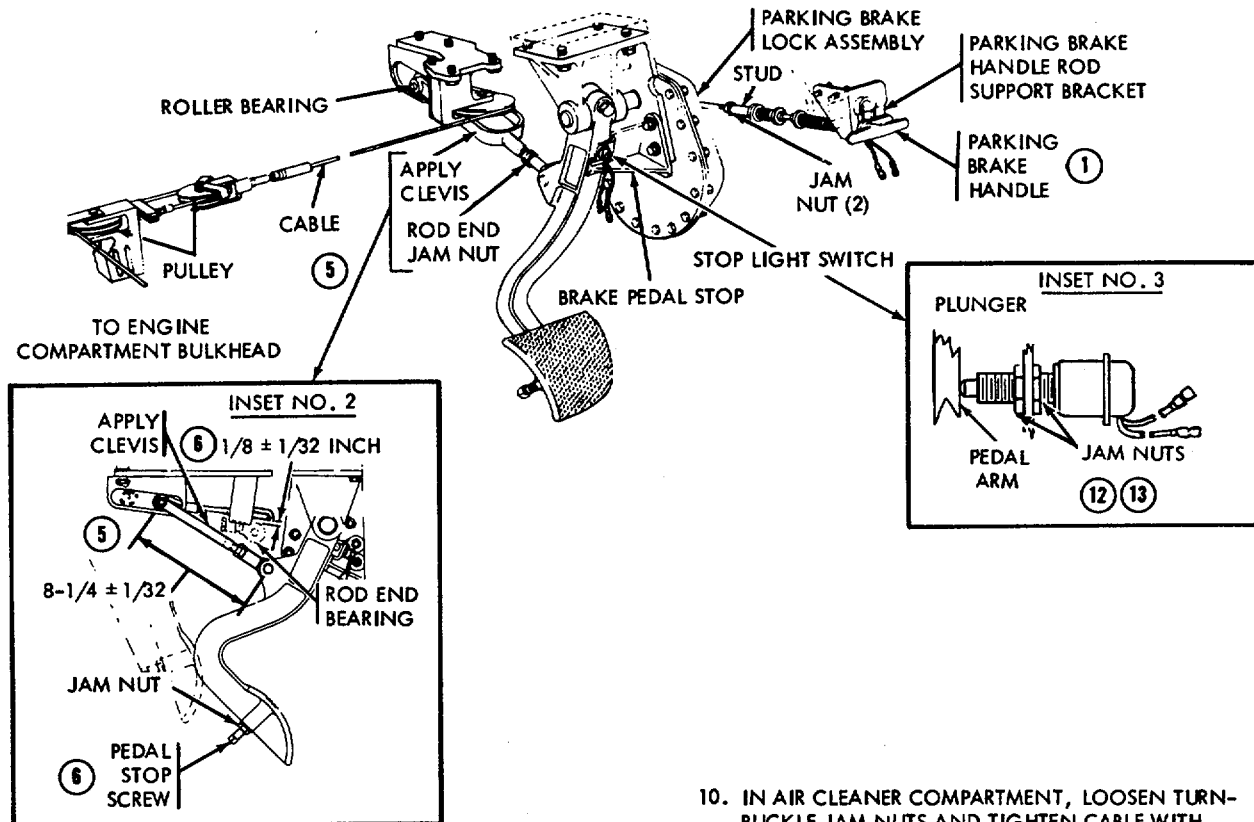

5. AT DRIVER'S BRAKE PEDAL, CHECK APPLY CLEVIS LENGTH (INSET NO. 2). IF NOT  $8-1/4 \pm 1/32$  INCHES, LOOSEN JAM NUT, REMOVE COTTER PIN AND CLEVIS PIN, AND ADJUST CLEVIS LENGTH TO  $8-1/4 \pm 1/32$  INCHES PIN CENTER TO PIN CENTER. CONNECT CLEVIS TO PEDAL AND TIGHTEN JAM NUT.
6. LOOSEN JAM NUT AND ADJUST PEDAL STOP SCREW TO PROVIDE  $1/8 \pm 1/32$  INCH CLEARANCE BETWEEN ROD END AND PULLEY WITH PEDAL STOP SCREW BOTTOMED ON HULL PLATE (INSET 2).
7. IN AIR CLEANER COMPARTMENT, REMOVE SAFETY WIRE AND LOOSEN TURNBUCKLE.
8. INSTALL CLEVIS PIN AND COTTER PIN TO CONNECT CLEVIS TO EQUALIZER PLATE.
9. ADJUST ROD END OF CROSSOVER PULLEY AT HULL BRACKET SO THAT PULLEY AND CABLE ARE ALIGNED TO PREVENT BINDING. INSTALL CLEVIS PIN AND COTTER PIN.

10. IN AIR CLEANER COMPARTMENT, LOOSEN TURNBUCKLE JAM NUTS AND TIGHTEN CABLE WITH TURNBUCKLE UNTIL BRAKE APPLY LEVERS START TO MOVE. LOOSEN TURNBUCKLE 1/2 TURN AND TIGHTEN JAM NUTS. INSTALL SAFETY WIRE ON TURNBUCKLE.

#### STOP LIGHT SWITCH ADJUSTMENT

11. TURN VEHICLE MASTER SWITCH ON.
12. ADJUST SWITCH JAM NUTS (INSET NO. 3) SO THAT BRAKE PEDAL ARM DEPRESSES PLUNGER AND TURNS STOP LIGHTS OFF WHEN PEDAL IS FULLY RELEASED (AGAINST STOP).
13. DEPRESS PEDAL 1/2 INCH AND READJUST JAM NUTS AS REQUIRED TO MAKE STOP LIGHTS COME ON. RELEASE BRAKE PEDAL AND ASSURE THAT LIGHTS GO OUT. TIGHTEN JAM NUTS.

**NOTE.** ROD END BEARINGS AND/OR CLEVISES INSTALLED ON CONTROL CABLE ASSEMBLIES MUST HAVE AT LEAST  $3/8$  INCH THREAD ENGAGEMENT FOR STRENGTH AND SAFETY, AND MUST BE LOCKED IN POSITION WITH JAM NUTS.

WE 12146

Figure 9-48.1. Brake control and linkage adjustment (2 of 2)

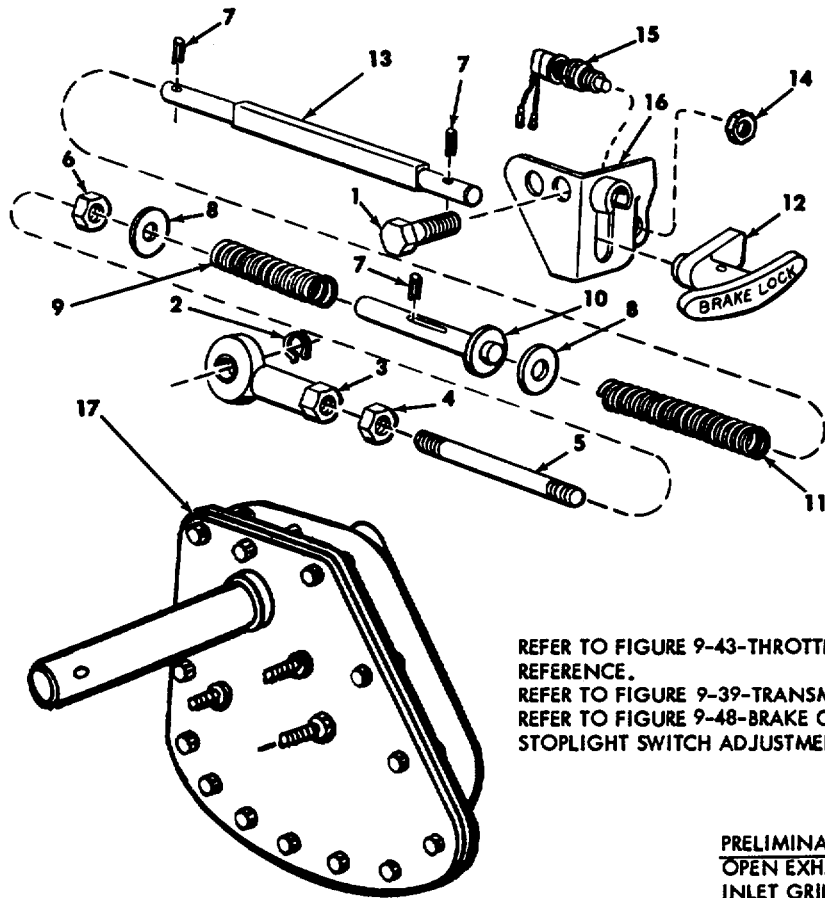

**REMOVAL/INSTALLATION**

REPLACE UNSERVICEABLE ITEMS AS REQUIRED.

1. SCREW (2)
2. RETAINING RING
3. ROD END BEARING
4. JAM NUT
5. STUD
6. JAM NUT
7. SPRING PIN (3)
8. FLAT WASHER (2)
9. SPRING
10. SLEEVE
11. SPRING
12. KNOB
13. ROD
14. NUT (2)
15. SWITCH
16. BRACKET
17. LOCK ASSEMBLY

REFER TO FIGURE 9-43-THROTTLE AND BRAKE LOCATIONAL REFERENCE.  
 REFER TO FIGURE 9-39-TRANSMISSION INTERNAL BRAKE ADJUSTMENT.  
 REFER TO FIGURE 9-48-BRAKE CONTROL CABLE, LINKAGE, AND STOPLIGHT SWITCH ADJUSTMENT.

**PRELIMINARY STEPS**

OPEN EXHAUST GRILLES AND REMOVE ENGINE AIR INLET GRILLE AND ACCESS COVER (FIGURE 9-3 STEPS 1 THROUGH 5).

**ADJUSTMENT**

1. WITH PARKING BRAKE HANDLE IN "OFF" (DOWN) POSITION, LOOSEN JAM NUTS (4 AND 6) AND TURN STUD (5) UNTIL PARKING BRAKE LOCK ASSEMBLY BEGINS TO LOCK. CHECK THIS BY PARTIALLY DEPRESSING PEDAL TO SEE IF LOCK ASSEMBLY IS BEGINNING TO ACTUATE. BACK OFF ON STUD UNTIL BRAKE PEDAL WORKS FREELY THROUGH ITS FULL STROKE WITHOUT LOCKING. TIGHTEN JAM NUTS.
2. MOVE PARKING BRAKE HANDLE (12) TO LOCK POSITION AND FULLY DEPRESS PEDAL TO CHECK PARKING BRAKE LOCK. RELEASE LOCK AND CHECK LEVERS ON TRANSMISSION FOR FULL RELEASE. CABLE SHOULD REMAIN TAUT WHEN PEDAL IS RELEASED.
3. ADJUST PARKING BRAKE WARNING LIGHT SWITCH (15 ABOVE) WITH PARKING BRAKE HANDLE IN "OFF" (DOWN) POSITION AND VEHICLE MASTER SWITCH ON. ADJUST SWITCH POSITION WITH JAM NUTS (14) UNTIL WARNING LIGHT IN PANEL IS OFF. (SWITCH OPEN).

WE 11205

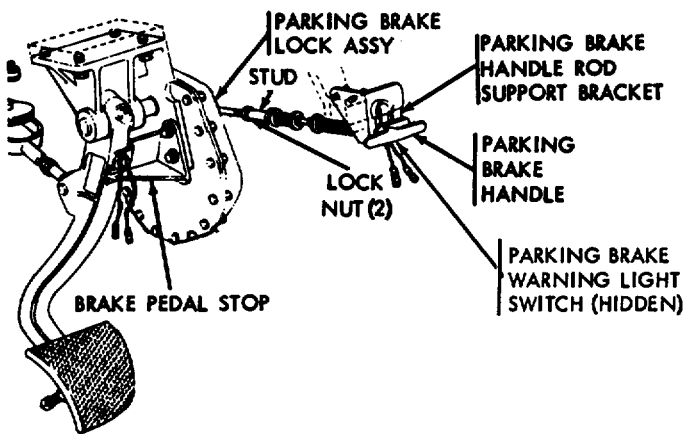
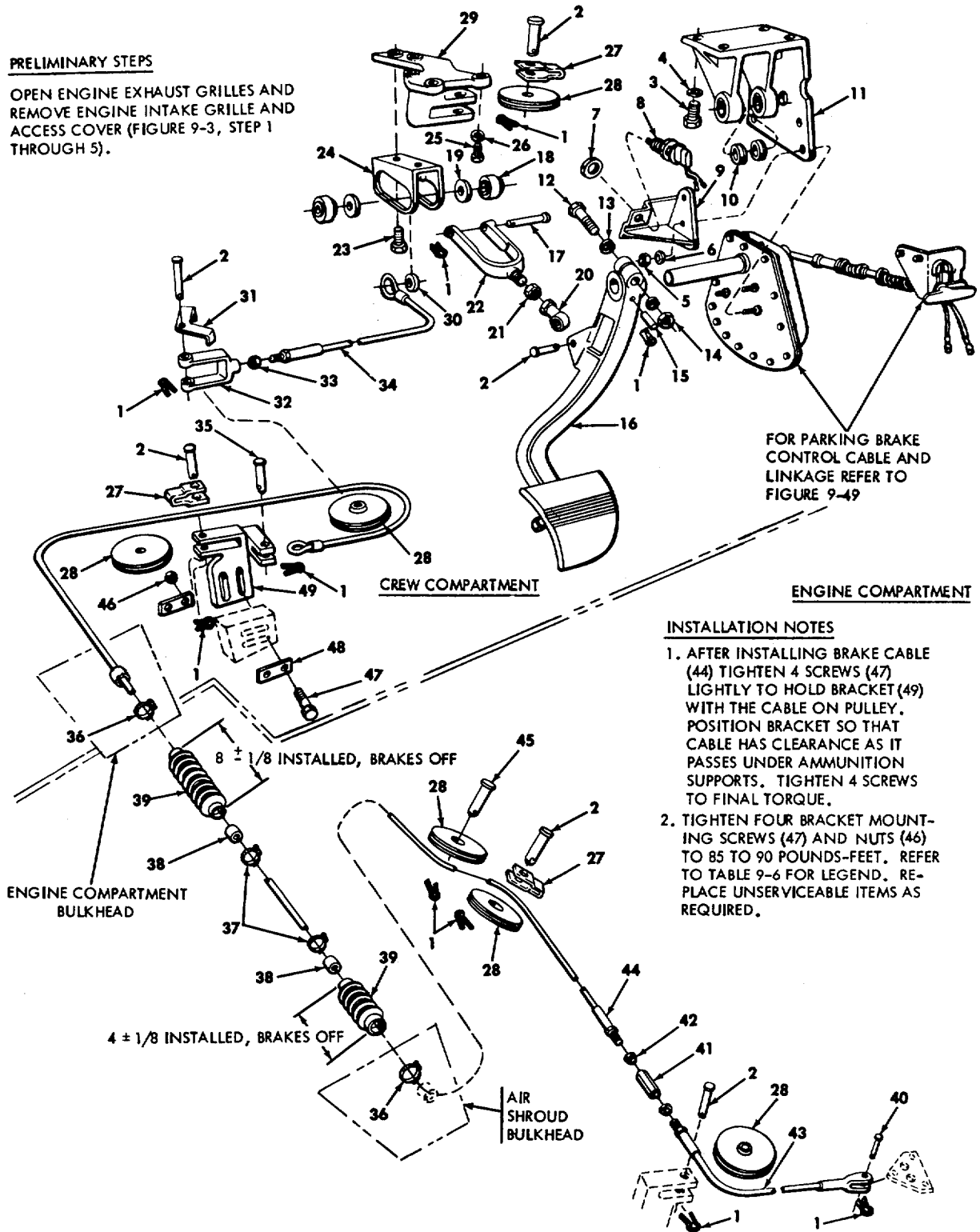

Figure 9-49. Removal/installation/adjustment - parking brake assembly

**PRELIMINARY STEPS**

OPEN ENGINE EXHAUST GRILLES AND REMOVE ENGINE INTAKE GRILLE AND ACCESS COVER (FIGURE 9-3, STEP 1 THROUGH 5).



FOR PARKING BRAKE CONTROL CABLE AND LINKAGE REFER TO FIGURE 9-49

**INSTALLATION NOTES**

1. AFTER INSTALLING BRAKE CABLE (44) TIGHTEN 4 SCREWS (47) LIGHTLY TO HOLD BRACKET (49) WITH THE CABLE ON PULLEY. POSITION BRACKET SO THAT CABLE HAS CLEARANCE AS IT PASSES UNDER AMMUNITION SUPPORTS. TIGHTEN 4 SCREWS TO FINAL TORQUE.
2. TIGHTEN FOUR BRACKET MOUNTING SCREWS (47) AND NUTS (46) TO 85 TO 90 POUNDS-FEET. REFER TO TABLE 9-6 FOR LEGEND. REPLACE UNSERVICEABLE ITEMS AS REQUIRED.

WE 12024 |

Figure 9-50. Removal/installation/repair - brake control cables and linkage (1 of 2)

REFER TO TABLE 9-6 FOR LEGEND  
REFER TO FIGURE 9-43 - THROTTLE AND BRAKE CONTROL LOCALATIONAL REFERENCE.  
REFER TO FIGURE 9-39 - TRANSMISSION INTERNAL BRAKE ADJUSTMENT.  
REFER TO FIGURE 9-49 - PARKING BRAKE AND WARNING LIGHT SWITCH ADJUSTMENT.  
REFER TO FIGURE 9-48 - BRAKE CONTROL CABLE, LINKAGE, AND STOPLIGHT SWITCH ADJUSTMENT.

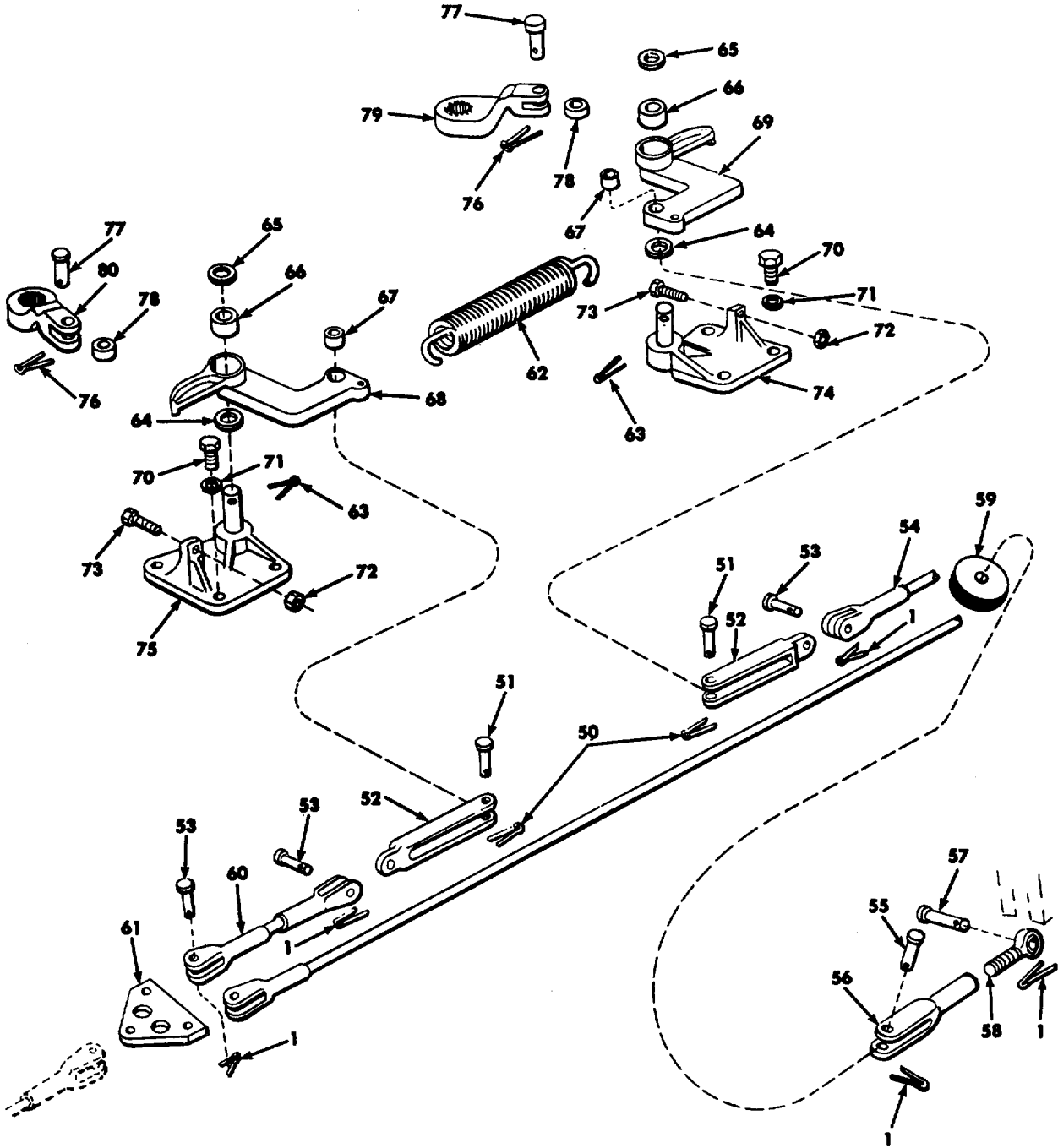

REPLACE UNSERVICEABLE ITEMS AS REQUIRED.

WE 11207

Figure 9-51. Removal/installation/repair - brake control cables and linkage (2 of 2)

TABLE 9-6. LEGEND FOR FIGURES 9-50 AND 9-51

ITEM NO.	DESCRIPTION	ITEM NO.	DESCRIPTION	ITEM NO.	DESCRIPTION
1	CotterPin (17)	28	Pulley (6)	55	Clevis Pin (2)
2	Clevis Pin (6)	29	Bracket	56	Clevis
3	Screw (4)	30	Spacer	57	Clevis Pin
4	Flat Washer (4)	31	Retainer	58	Rod End Bearing
5	Nut (3)	32	Clevis	59	Pulley
6	Flat Washer (3)	33	Jam Nut	60	Wire Rope Assy.
7	Jam Nut (2)	34	Wire Rope Assy	61	Equalizer Plate
8	Stoplight Switch	35	Clevis Pin	62	Spring
9	Bracket	36	Clamp (2)	63	Cotter Pin (2)
10	Bearing (2)	37	Clamp (2)	64	Washer (2)
11	Bracket	38	Bushing (2)	65	Washer (2)
12	Screw	39	Bellows (2)	66	Bearing (2)
13	Flat Washer (2)	40	Clevis Pin	67	Bearing (2)
14	Nut	41	Turnbuckle	68	Cam Lever, Left
15	Dowel Pin	42	Jam Nut (2)	69	Cam Lever, Right
16	Pedal	43	Wire Rope Assy	70	Screw (6)
17	Clevis Pin	44	Wire Rope Assy	71	Flat Washer (6)
18	Bearing (2)	45	Clevis Pin	72	Jam Nut (2)
19	Flat Washer (2)	46	Nut (4)	73	Screw (2)
20	Rod End Bearing	47	Screw (4)	74	Cam Lever Bracket, Right
21	Jam Nut	48	Plate (4)	75	Cam Lever Bracket, Left
22	Clevis	49	Bracket	76	Cotter Pin (2)
23	Screw (2)	50	Cotter Pin (2)	77	Clevis Pin (2)
24	Bracket	51	Clevis Pin (2)	78	Bearing (2)
25	Screw (3)	52	Clevis (2)	79	Brake Apply Lever, Right
26	Flat Washer (3)	53	Clevis Pin (4)	80	Brake Apply Lever, Left
27	Retainer(3)	54	Wire Rope Assy.		



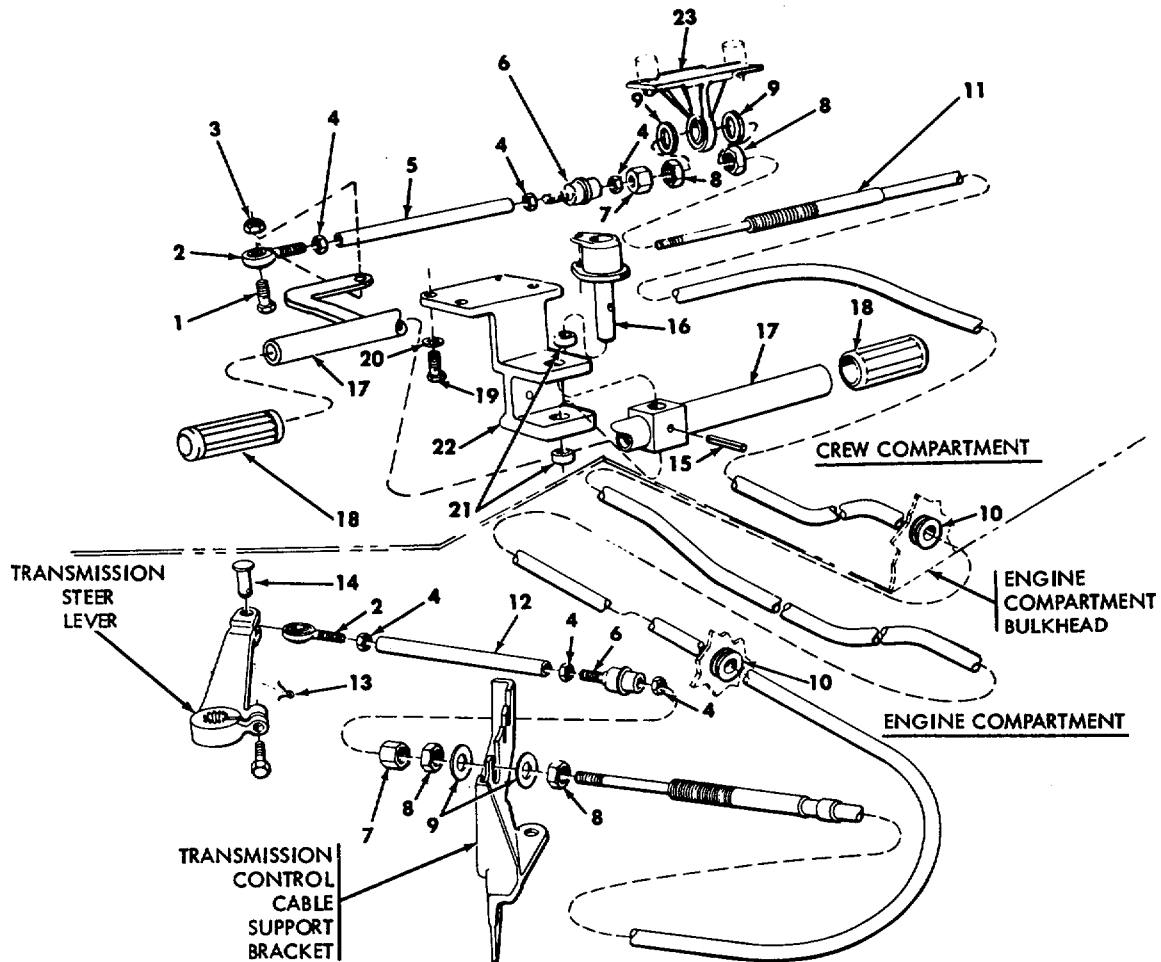

**LEGEND**

- |                        |                       |                      |
|------------------------|-----------------------|----------------------|
| 1. SCREW               | 10. GROMMET (2)       | 19. SCREW (4)        |
| 2. ROD END BEARING (2) | 11. CONTROL ASSEMBLY  | 20. FLAT WASHER (4)  |
| 3. NUT                 | 12. TUBE (6-3/8 INCH) | 21. BEARING (2)      |
| 4. JAM NUT (6)         | 13. PIN, COTTER       | 22. SUPPORT ASSEMBLY |
| 5. TUBE (7-3/16 INCH)  | 14. PIN, CLEVIS       | 23. BRACKET          |
| 6. COUPLING (2)        | 15. SPRING ROLL PIN   |                      |
| 7. SEAL NUT (2)        | 16. ROD               |                      |
| 8. JAM NUT (4)         | 17. T-BAR             |                      |
| 9. FLAT WASHER (4)     | 18. GRIP (2)          |                      |

REFER TO FIGURES 9-42 AND 9-43.1 - LOCATIONAL REFERENCE.

REFER TO FIGURES 9-53 AND 9-53.1 FOR ADJUSTMENT.

**PRELIMINARY STEPS**

- A. REMOVE VEHICLE BATTERIES (FIG. 9-97).
- B. OPEN ENGINE EXHAUST GRILLES AND REMOVE ENGINE ACCESS COVER (FIG. 9-3, STEPS 3 THROUGH 5). PLACE WOODEN BLOCK APPROXIMATELY 2-1/2 INCHES THICK ON ENGINE STEP PLATE UNDER GRILLE SUPPORT. IF ACCESS TO ENGINE BULKHEAD IS REQUIRED, ALSO REMOVE INTAKE GRILLE (FIG. 9-3, STEP 1).

C. REMOVE 4 SCREWS, 3 WASHERS, AND PROTECTIVE PLATE FROM BATTERY COMPARTMENT (FIG. 9-45.1, ITEM 3).

D. REMOVE 2 SCREWS, WASHERS, AND PROTECTIVE PLATE FROM TRANSMISSION CONTROL CABLE SUPPORT BRACKET (FIG. 9-4, ITEM 12).

REPLACE UNSERVICEABLE PARTS AS REQUIRED. REFER TO TABLE 9-7 FOR REMOVAL/INSTALLATION PROCEDURE.

**NOTE.** ROD END BEARINGS AND/OR CLEVISES INSTALLED ON CONTROL CABLE ASSEMBLIES MUST HAVE AT LEAST 3/8 INCH THREAD ENGAGEMENT FOR STRENGTH AND SAFETY, AND MUST BE LOCKED IN POSITION WITH JAM NUTS.

WE 12147

Figure 9-52. Disassembly/assembly/repair - land steer control cable and linkage

TABLE 9-7. REMOVAL/INSTALLATION/REPAIR - LAND STEER CONTROL CABLE AND LINKAGE

(Refer to figure 9-52 for preliminary steps and item reference numbers)

**REMOVAL**

1. Review control cable handling precautions, table 9-9. 1.
2. Remove cotter pin (13), clevis pin (14) and bearing (2) from transmission steer lever.
3. Hold control rod end and loosen jam nut (4). Remove coupling-tube-rod bearing assembly (6, 4, 12, 4, 2) and jam nut (4) from control assembly.
4. Hold cable housing and remove seal assembly (7), two jam nuts (8), and two washers (9).
5. Remove two grommets (10), and retaining straps.
6. In driver's compartment, remove nut (3) and screw (1).
7. Hold control rod end to prevent twisting and loosen coupling jam nut (4). Remove coupling assembly (6, 4, 5, 4, 2) and jam nut (4)°
8. Remove seal nut (7). Hold control housing and loosen jam nuts (8) at the hull mounting bracket. Remove outer jam nut (8) and washer (9).
9. Remove control assembly (11) from mounting bracket and remove second washer (9) and jam nut (8). Avoid unnecessary force and sharp bends by sliding control assembly to rear of vehicle. Do Not Twist Control Cable.
10. Remove control assembly (11) through engine compartment holding control assembly by the outer housing. Do not lift or handle control assembly by rod ends.

**INSTALLATION**

1. Review step 1 above.
2. Assemble a steer bar coupling assembly as follows:
  - a. Screw jam nut (4) on bearing (2). Leave ½" of threads.
  - b. Screw long (7-3/16") tube (5) onto bearing.
  - c. Screw jam nut (4) onto coupling (6) - leave ½" of threads.
  - d. Screw coupling (6) into tube (5).
3. Assemble a transmission steer control coupling the same as step 2 above except use a short (6-3/8") tube (12).
4. From engine compartment, thread control through battery compartment rear bulkhead and engine compartment bulkhead. Install grommets (10)
5. From crew compartment place control assembly along right slope plate to front of driver's compartment. See figure 9-42.
6. Install jam nut (8) and washer (9) on control assembly (11). Leave 2" of thread on end of control assembly.
7. Install control assembly through hull mounting bracket (23) eye and install washer (9), nut (8), and seal assembly (7). Do not tighten jam nuts (8). Stroke control rod several times to permit internal components to position themselves. Control should operate freely.
8. Install jam nut (4) onto control rod - leave ½" of threads.
9. Install long coupling assembly (6, 4, 5, 4, 2)° Hold control rod from twisting.
10. Attach control to T-bar with screw (1) and nut (3).
11. Using improvised tool as shown in figure 9-53. 1, position and tighten jam nuts.
12. Operate T-bar to assure equal motion of steer control lever to both left and right side.
13. Install cable retaining straps, figure 9-42.
14. In engine compartment, install jam nut (8), two washers (9), and 2nd jam nut (8) on cable housing. Leave 1" of threads to first lock nut and ½" between washers. Install rear seal assembly (7).
15. Install jam nut (4) on control rod -leave ½" of threads.
16. Install rear (short) coupling assembly (6, 4, 12, 4, 2).
17. Place control assembly (11) in rear slot of transmission cable support bracket.
18. Operate T-bar several times to permit internal components to position themselves. Position control assembly in transmission cable support bracket.
19. Adjust linkage (figure 9-53).

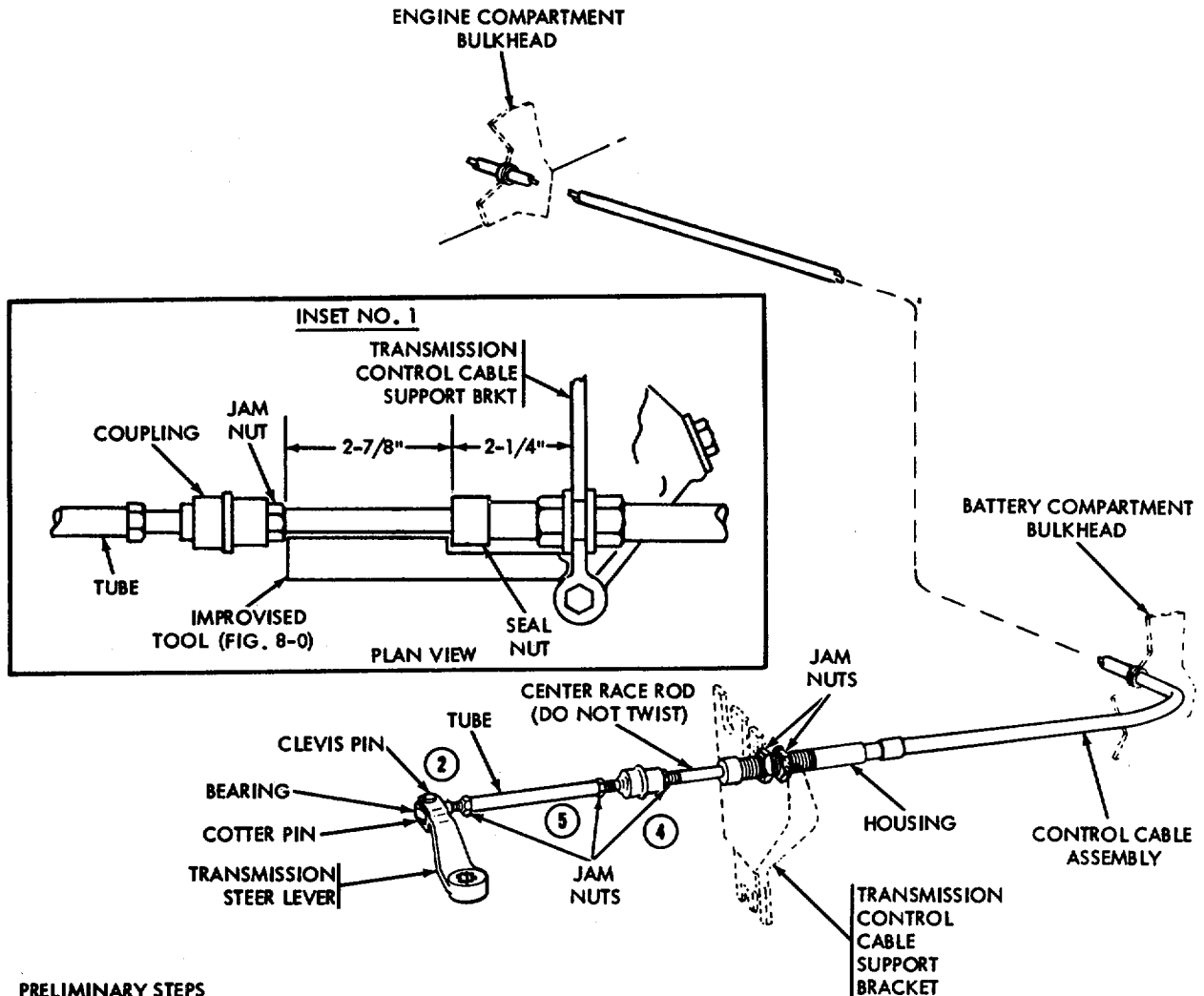

#### PRELIMINARY STEPS

- A. OPEN ENGINE EXHAUST GRILLES AND REMOVE ENGINE ACCESS COVER (FIG. 9-3, STEPS 3 THROUGH 5). PLACE WOODEN BLOCK APPROXIMATELY 2-1/2 INCHES THICK ON ENGINE STEP PLATE UNDER GRILLE SUPPORT. IF ACCESS TO BULKHEAD IS REQUIRED, ALSO REMOVE AIR INTAKE GRILLE (FIG. 9-3, STEP 1).
- B. REMOVE TWO SCREWS, WASHERS AND PROTECTIVE PLATE FROM TRANSMISSION CONTROL CABLE SUPPORT BRACKET.

#### LAND STEER CONTROL CABLE ADJUSTMENT

1. REVIEW CONTROL CABLE HANDLING PRECAUTIONS (TABLE 9-9.1).
2. AT TRANSMISSION, DISCONNECT CONTROL CABLE FROM TRANSMISSION STEER LEVER BY REMOVING COTTER PIN AND CLEVIS PIN.
3. TURN STEER LEVER EACH DIRECTION AND RELEASE. LEVER SHOULD RETURN TO NO STEER POSITION, WITH POINTER (UNDER STEER LEVER) POINTED FORWARD. IF NOT, NOTIFY SUPPORT MAINTENANCE (TM 9-2520-249-35).
4. LOOSEN AND ADJUST JAM NUTS SECURING CABLE AT COUPLING SO THAT IMPROVED TOOL (FIG. 8-0) FITS BETWEEN COUPLING JAM NUT AND TRANSMISSION CONTROL CABLE SUPPORT BRACKET AS SHOWN IN INSET NO. 1. TIGHTEN JAM NUTS.
5. LOOSEN JAM NUTS ON TUBE. ADJUST TUBE TO OBTAIN FREE PIN FIT AT TRANSMISSION STEER LEVER, WITH IMPROVED TOOL STILL POSITIONED AS SHOWN IN INSET NO. 1. TIGHTEN JAM NUTS AND REMOVE IMPROVED TOOL.

WE 12148

Figure 9-53. Land steer control cable and linkage adjustment (1 of 2)

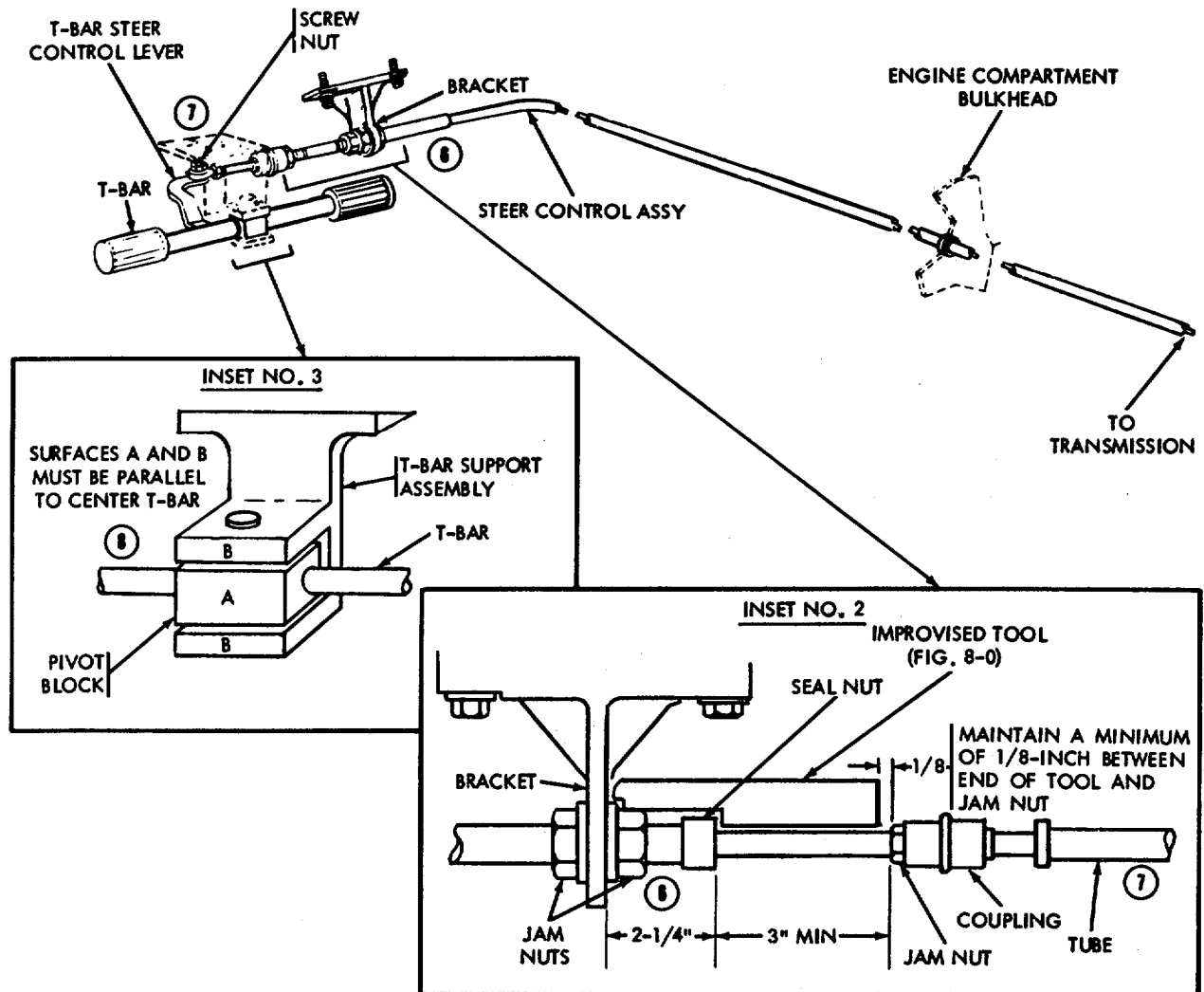

6. AT DRIVER'S COMPARTMENT, LOOSEN AND ADJUST JAM NUTS SECURING CABLE AT HULL MOUNTED BRACKET USING IMPROVISED TOOL (FIG. 8-0). MAINTAIN 3 INCH MINIMUM (ADD 1/8-INCH BETWEEN END OF TOOL AND JAM NUT) AND 2-1/4 INCH DIMENSIONS AS SHOWN IN INSET 2. TIGHTEN JAM NUTS AND SEAL NUT.
7. DISCONNECT CONTROL CABLE BY REMOVING NUT AND SCREW AT T BAR STEER CONTROL LEVER. LOOSEN JAM NUTS ON TUBE.
8. CENTER T BAR. REAR FACE OF T BAR PIVOT BLOCK MUST BE FLUSH WITH OR PARALLEL TO FACE OF SUPPORT ASSEMBLY (SEE INSET NO. 3). ADJUST TUBE TO OBTAIN FREE FIT OF SCREW AT T BAR STEER CONTROL LEVER, AND INSTALL SCREW AND NUT.

**NOTE. 1. THREAD ENGAGEMENT AT BEARINGS, COUPLINGS AND ENDS OF CONTROL CABLE RODS MUST BE AT LEAST 3/8 INCH FOR STRENGTH AND SAFETY.**

**2. JAM NUTS MUST BE KEPT TIGHT AT ALL TIMES TO PREVENT VIBRATION AND WEAR AND TO MAINTAIN ADJUSTMENT.**

WE 12149

Figure 9-53.1. Land steer control cable and linkage adjustment (2 of 2)

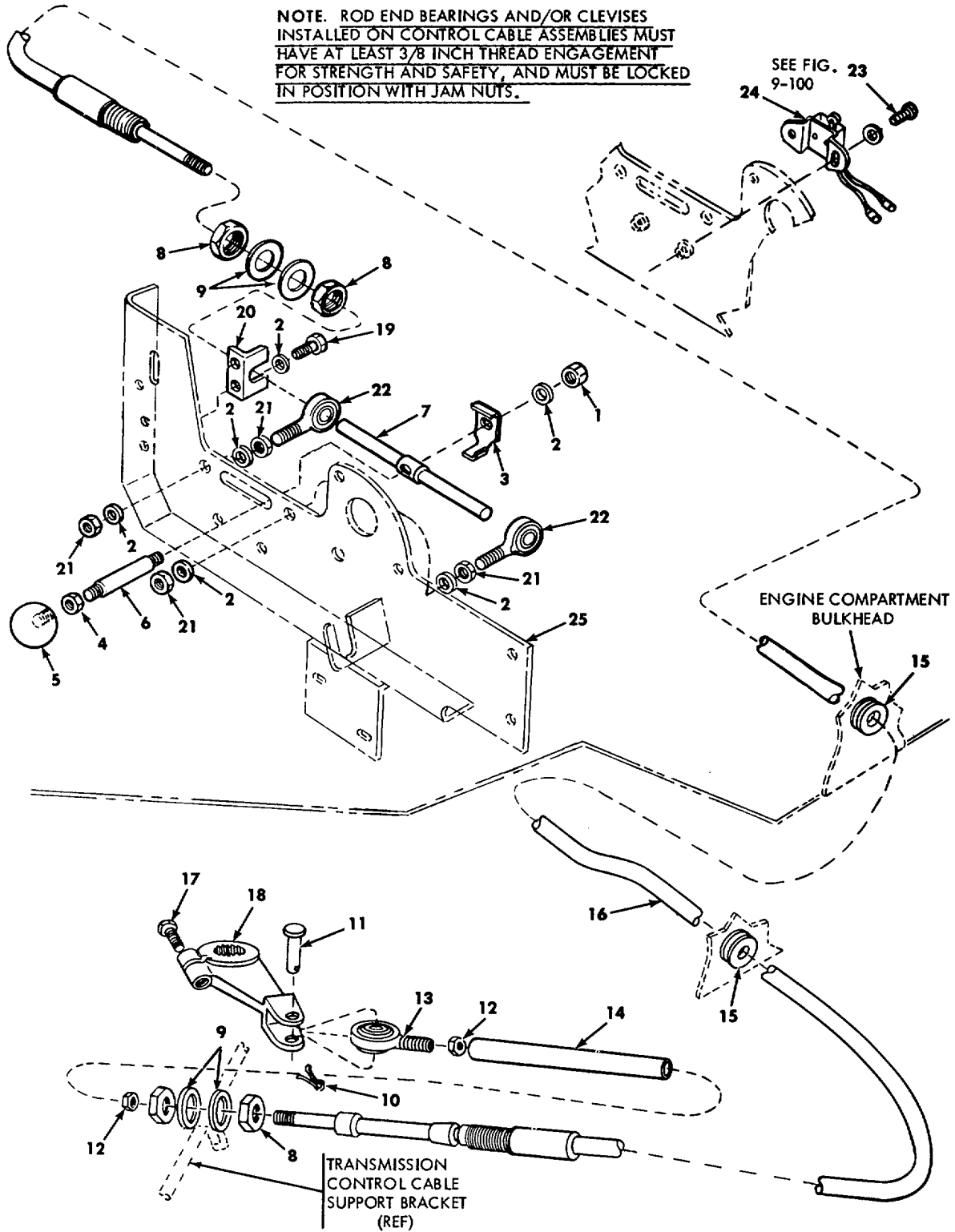

REFER TO TABLE 9-9 FOR LEGEND  
REFER TO TABLE 9-8 FOR REMOVAL/INSTALLATION PROCEDURE.

WE 12152

Figure 9-54. Disassembly/assembly/repair - water steer control cable and linkage

TABLE 9-8. REMOVAL/INSTALLATION/REPAIR - WATER STEER CONTROL CABLE AND LINKAGE

PRELIMINARY STEPS

- A. Open engine exhaust grilles and remove engine access cover (Fig. 9-3, steps 3 through 5). Place wooden block approximately 2-1/2 inches thick on engine step plate under grille support. If access to bulkhead is required, also remove intake grille (Fig. 9-3, step 1).
- B. Remove vehicle batteries (Figure 9-97).
- C. Remove four screws, three washers, and protective plate from battery compartment (Figure 9-45.1, item 3), D. Remove two screws, washers, and protective plate from control cable support at transmission (Figure 9-4, item 12).
- E. Review control cable handling precautions, table 9-9. 1.

CABLE REMOVAL (Refer to Figure 9-54 for item reference numbers. )

- 1. Remove nut (1), washer (2), and switch actuator (3). Remove nut (4), knob (5), and pin (6) as an assembly.
- 2. Remove two nuts (21), two washers (2) and rear bearing (22) and remove rod (7) from control cable assembly. Loosen jam nuts (8) retaining control cable in support bracket (20) on control support plate (25).
- 3. Remove cotter pin (10) and clevis pin (11) from transmission water steer lever (18).
- 4. Loosen jam nut (8) and remove cable assembly from transmission control cable support bracket.
- 5. Loosen jam nut (12) and remove bearing (13), jam nuts (12) and connector (14) from cable assembly.
- 6. Remove jam nuts (8) and flat washers (9) from both ends of cable assembly. Remove grommets (15) from cable and bulkheads. Remove retaining straps along right side of null (Refer to Figure 9-42).
- 7. Remove control cable (16) out through engine compartment. Handle control assembly by outer casing and not by race rod or inner cable.

CABLE INSTALLATION

Follow steps 7 through 1. Refer to Figure 9-55 for adjustment of control cable.

TABLE 9-9. LEGEND FOR FIGURE 9-54

1. Jam nut	10. Pin, cotter	180 Water steer lever
2. Flat Washer (8)	11. Pin, clevis	19. Screw (2)
3. Switch actuator	12. Jam nut (2)	20. Bracket
4. Nut	13. Rod end bearing	21. Nut (4)
5. Knob	14. Connector	22. Bearing (2)
6. Pin	15. Grommet (2)	23. Screw (2)
7. Rod	16. Control cable assembly	24. Switch assembly
8. Jam nut (4)	17. Screw	25. Control support plate
9. Flat washer (4)		

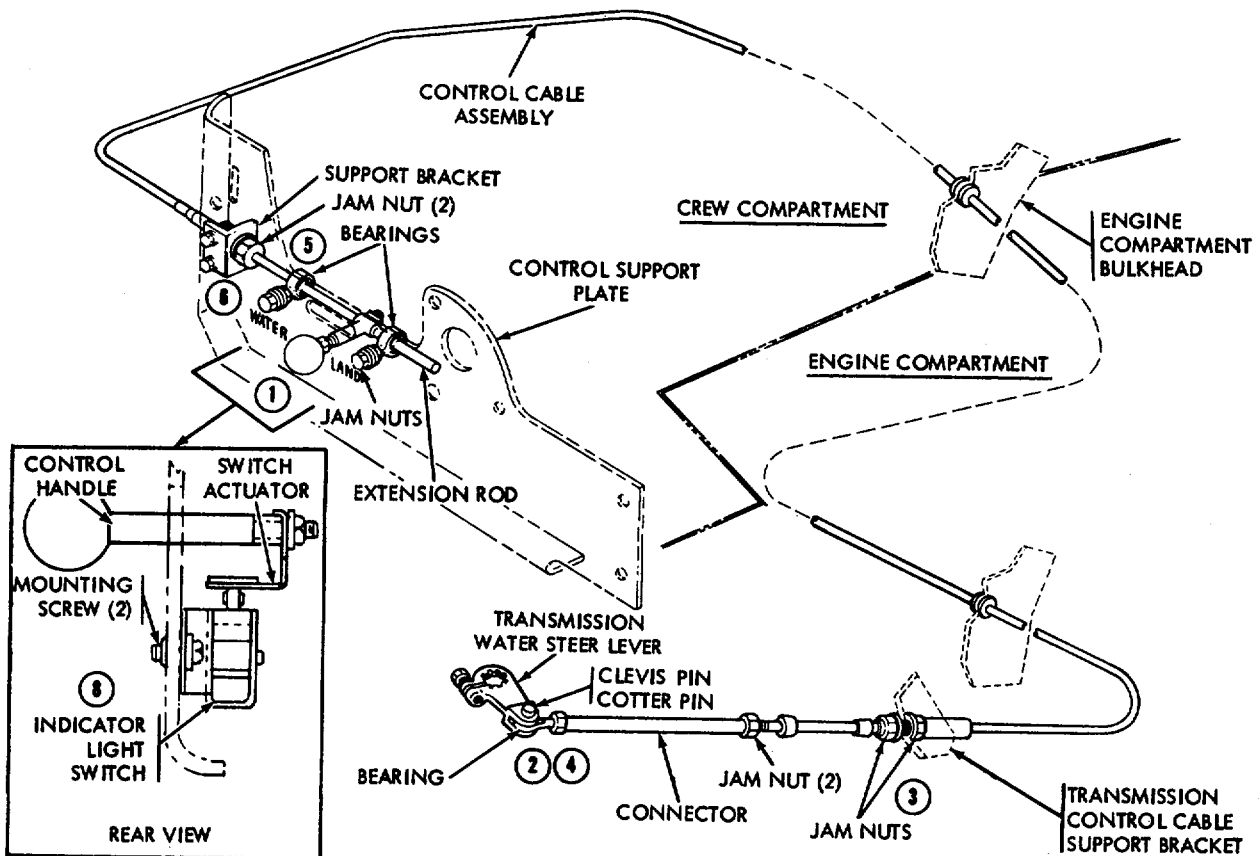

NOTE. WATER STEER CONTROL HANDLE SHOWN IN LAND POSITION.

#### PRELIMINARY STEPS.

- A. OPEN ENGINE EXHAUST GRILLE AND REMOVE ENGINE ACCESS COVER (FIGURE 9-3, STEP 2 THROUGH 5).
- B. REMOVE TWO SCREWS, WASHERS AND PROTECTIVE PLATE FROM CONTROL CABLE SUPPORT AT TRANSMISSION (FIGURE 9-4, ITEM 12).
- C. REVIEW FIGURE 9-42 FOR LOCATIONAL REFERENCE AND TABLE 9-9.1 FOR CONTROL CABLE HANDLING PRECAUTIONS.

#### WATER STEER CONTROL ADJUSTMENT.

1. PLACE DRIVER'S WATER STEER CONTROL HANDLE IN LAND POSITION.
2. AT TRANSMISSION, DISCONNECT CABLE FROM LEVER BY REMOVING COTTER PIN AND CLEVIS PIN. ROTATE LEVER COUNTERCLOCKWISE TO LAND (L) DETENT POSITION.
3. LOOSEN JAM NUTS AT TRANSMISSION CONTROL CABLE SUPPORT BRACKET AND ADJUST FOR FREE PIN FIT AT LEVER. ADDITIONAL ADJUSTMENT IS AVAILABLE AT CONNECTOR IF REQUIRED. TIGHTEN JAM NUTS.

NOTE. LOOSEN RETAINER STRAPS AS REQUIRED TO MAKE ADJUSTMENT (FIG. 9-42).

4. INSTALL CLEVIS PIN AND COTTER PIN TO CONNECT ROD END TO LEVER.
5. PLACE DRIVER'S WATER STEER CONTROL HANDLE IN WATER POSITION. IF EXTENSION ROD BOTTOMS OUT IN WATER POSITION, LOOSEN SUPPORT BRACKET JAM NUTS AND REPOSITION CONTROL CABLE HOUSING. TIGHTEN JAM NUTS.  
NOTE. IF CABLE HOUSING IS REPOSITIONED, RECHECK ADJUSTMENT AT TRANSMISSION (STEP 3).
6. CHECK FREEDOM OF MOVEMENT OF DRIVER'S WATER STEER CONTROL HANDLE. IF BINDING OCCURS, LOOSEN SUPPORT BRACKET JAM NUTS AND BEARING NUTS (FIGURE 9-54, ITEM 21), AND REALIGN EXTENSION ROD. TIGHTEN ALL JAM NUTS.

#### WATER STEER INDICATOR LIGHT SWITCH ADJUSTMENT

7. TURN VEHICLE MASTER SWITCH ON AND PLACE DRIVER'S WATER STEER CONTROL HANDLE IN LAND POSITION.
8. LOOSEN INDICATOR LIGHT SWITCH BRACKET MOUNTING SCREWS, AND POSITION SWITCH AGAINST ACTUATOR (SEE INSET) SO THAT INDICATOR LIGHT GOES OUT. TIGHTEN MOUNTING SCREWS.

WE 12151

Figure 9-55. Water steer control cable and linkage adjustment

Figure 9-56 Deleted

Figure 9-57 Deleted

Figure 9-58 Deleted

TABLE 9-9.1. CONTROL CABLE HANDLING PRECAUTIONS

**DESCRIPTION**

Control cables are precision control devices for transmitting push-pull movement. Because they are precision controls, precautions must be observed in their handling and installation if they are to function properly.

**HANDLING PRECAUTIONS**

Handle the assembly by outer housing only and not by rod ends.

Use care when tightening outer housing jam nuts to avoid twisting housing.

Use wrench on end rod flats whenever tightening or loosening jam nut or coupling to prevent twisting the inner core.

The control is quite flexible in one plane but when making a bend into another plane the control must be gently formed into position to give the internal parts a chance to adjust for the new direction. Tapping lightly with the hand or a rawhide mallet will help the internal parts to align themselves.

Before connecting the control ends, stroke control several times to allow the internal components to align themselves.

Do not use force or bend sharply, but form easily into position.

- NOTE.** hang on wall.
1. Store stock controls in standard figure 8 coils, preferably in their containers as received. If unpacked,
  2. Do not attempt to force oil into the control.
  3. Thread engagement at bearing, coupling, or center control rod should be at least 3/84nch for strength
  4. Keep jam nuts tight at all times to prevent vibration and wear.
- and safety.



**Section 9-4. TRACKS AND SUSPENSION**

**9-12. General**

a. This section contains organizational maintenance instructions for the vehicle suspension system as shown in figures 9-59, 9-60, and table 9-10

b. All two-piece bearings (cup and cone) are supplied only in matched sets.

c. Periodic lubrication will be in accordance with LO 9-2350-230-12. Assembly/installation instructions will specify additional lubrication procedures required in conjunction with assembly/installation.

d. Whenever plugs are used in suspension lubrication system, use only hardened hex recessed head plugs, FSN 4730-278-3462. The correct plugs are identified by embossed or raised markings radiating from corners of hex recess.





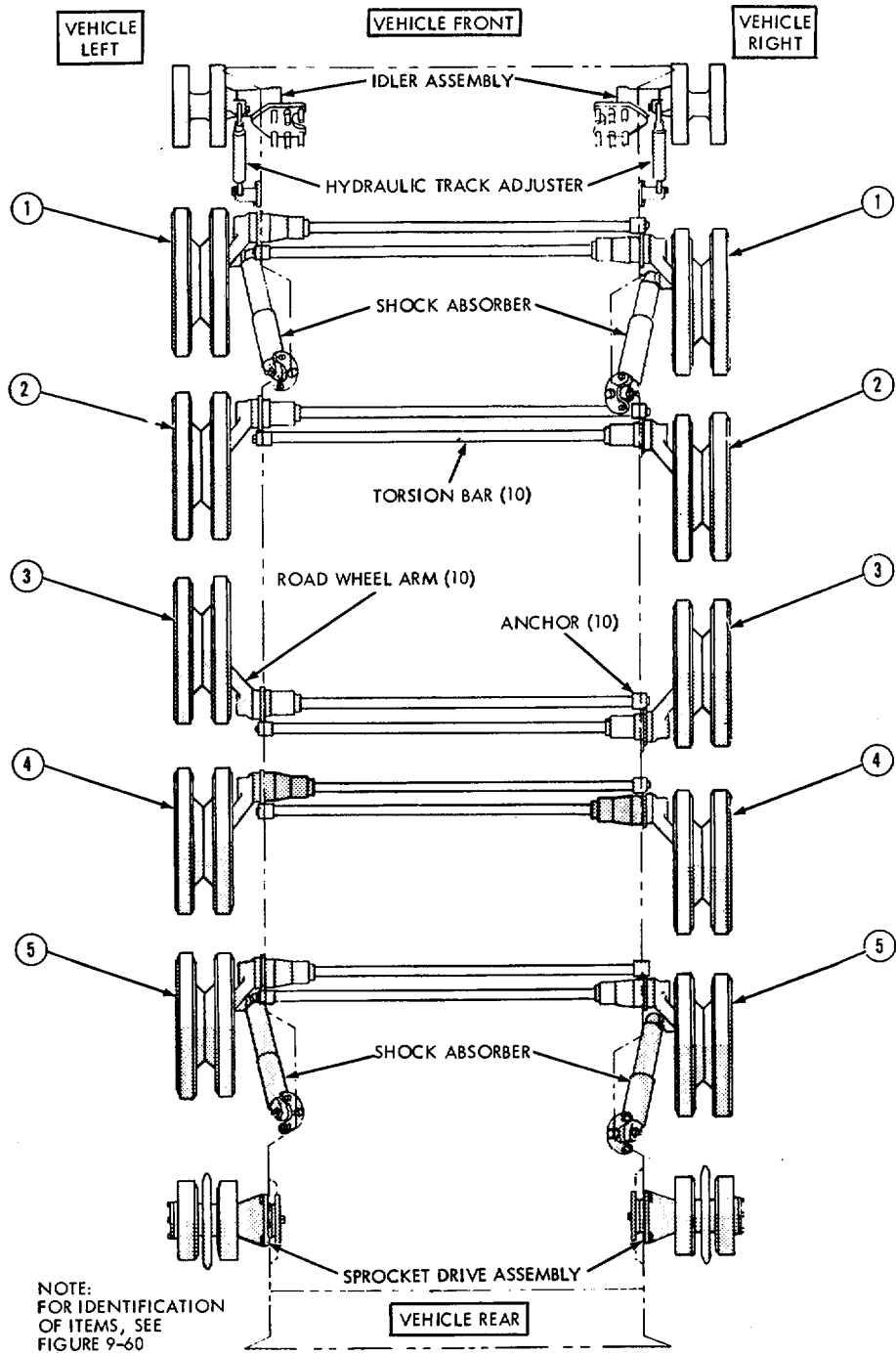





TABLE 9-10. TRACKS AND SUSPENSION

ASSEMBLY OR COMPONENT	FIGURE REFERENCE		
	REMOVE INSTALL	REPLACE	REPAIR
Road Wheels		9-61	
Torsion Bar and Road Wheel Arm Assembly		9-62	
Torsion Bar Anchors		9-63	
Road Wheel Spindle		9-64	
Position No. 2 and No. 3 Road Wheel Arm Housing and Shaft Assembly		9-65	9-65
Position No. 1, 4, and 5 Road Wheel Arm Housing and Shaft Assembly		9-66	9-66
Track Hydraulic Adjuster and Bracket		9-67	
Track Idler Wheels		9-68	
Idler Hub Assembly		9-69	
Idler Housing and Spindle Assembly		9-70	9-70
Sprocket Drive Shaft		9-71	
Sprocket and Sprocket Carrier Wheels		9-72	
Sprocket Hub and Support		9-73	9-73
Shock Absorber and Mounting Bracket		9-74	
Suspension System Seal Installation Specifications		9-75	
Suspension System Special Tools (1 of 4)	9-76		
Suspension System Special Tools (1. 1 of 4)	9-76.1		
Suspension System Special Tools (2 of 4)	9-77		
Suspension System Special Tools (3 of 4)	9-78		
Suspension System Special Tools (4 of 4)	9-79		
Track Shoe	9-80		
Replacing Damaged Track Shoe		9-81	
	<b>9-66</b>		



WE 70034

Figure 9-59. Vehicle suspension system

ITEM (FIG. 9-59)	VEHICLE POSITION	TORSION BAR PART NUMBER	IDENTIFYING ARROW (PRESET)	MATING ANCHOR (ON OPPOSITE SIDE OF VEHICLE) PART NUMBER	LOCATION OF BLIND SPLINE IN ANCHOR*	ROAD WHEEL ARM ASSEMBLY PART NUMBER
<b>RIGHT SIDE</b>						
(1)	FRONT	10948666-2		10948664-1	APPROX 7:30 O'CLOCK	10954288-2
(2)	FRONT INTERMEDIATE	10948665-2		10948664-4	APPROX 7:30 O'CLOCK	10954286
(3)	INTERMEDIATE	10948665-1		10948664-3	APPROX 4:30 O'CLOCK	10954286
(4)	REAR INTERMEDIATE	10948666-2		10948664-4	APPROX 7:30 O'CLOCK	11593592
(5)	REAR	10948666-2		10948664-4	APPROX 7:30 O'CLOCK	10954288-2
<b>LEFT SIDE</b>						
(1)	FRONT	10948666-1		10948664-2	APPROX 4:30 O'CLOCK	10954288-1
(2)	FRONT INTERMEDIATE	10948665-1		10948664-3	APPROX 4:30 O'CLOCK	10954286
(3)	INTERMEDIATE	10948665-2		10948664-4	APPROX 7:30 O'CLOCK	10954286
(4)	REAR INTERMEDIATE	10948666-1		1094664-3	APPROX 4:30 O'CLOCK	11593592
(5)	REAR	10948666-1		10948664-3	APPROX 4:30 O'CLOCK	10954288-1

\*AS VIEWED THROUGH VEHICLE FROM ROAD WHEEL ARM SIDE.

WE 66667

Figure 9-60. Vehicle suspension system component identification

Page 9-68.1 including figure 9-60.1 - deleted.

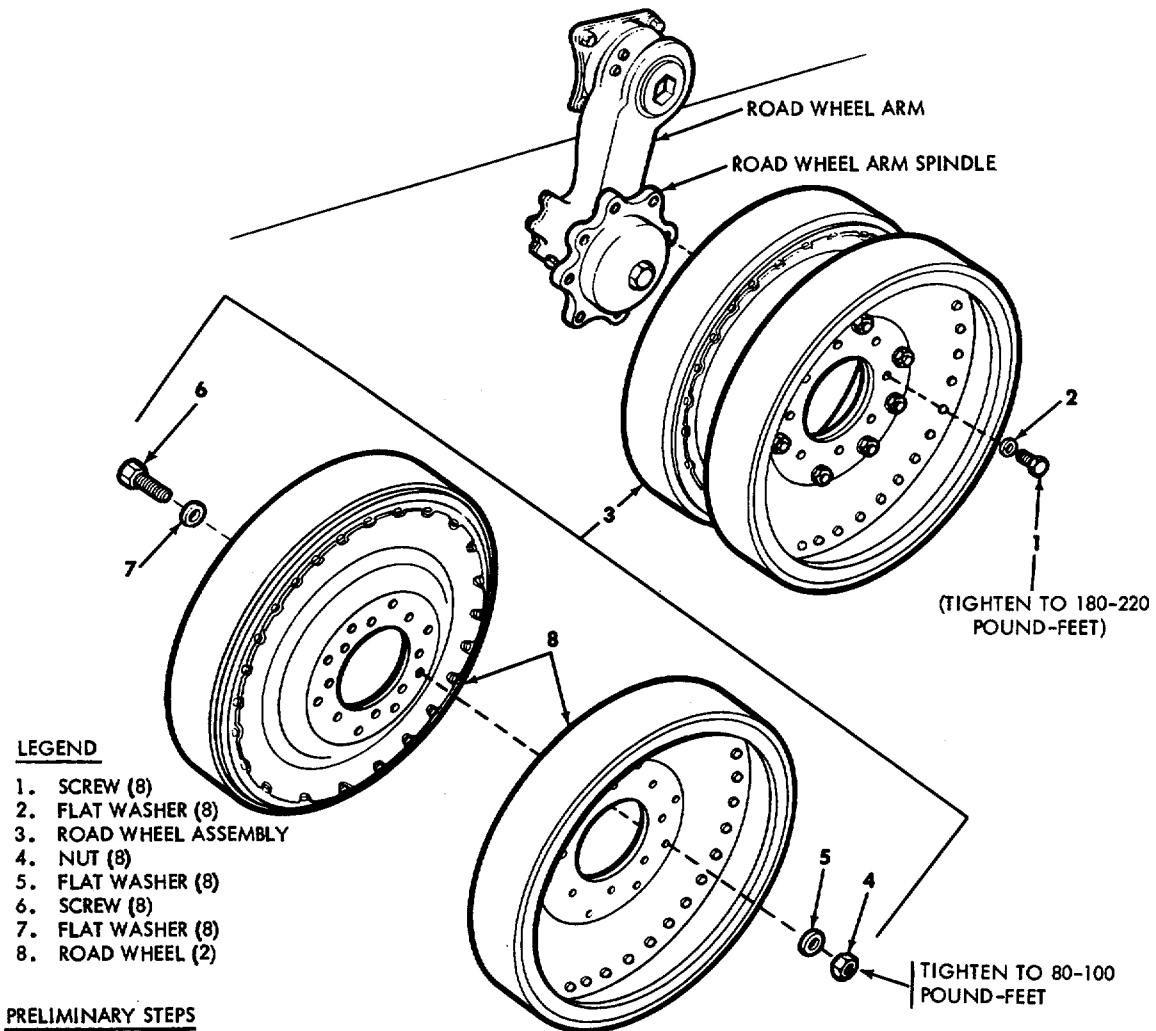
**PRELIMINARY STEPS**

- A. DISCONNECT TRACK (FIG. 5-5 ) AND REMOVE FROM TOP OF AFFECTED ROAD WHEEL ASSEMBLY.
- B. LOOSEN ITEM 1 ATTACHING ROAD WHEEL ASSEMBLY TO ROAD WHEEL ARM SPINDLE.
- C. PLACE HYDRAULIC JACK UNDER HULL, RAISE HULL UNTIL AFFECTED ROAD WHEELS CAN BE REMOVED.

**WARNING:** MAKE SURE JACK IS PROPERLY INSTALLED AND BLOCKED TO PREVENT INJURY TO PERSONNEL. PLACE CHOCKS AT FRONT AND REAR OF OPPOSITE TRACK.

**REMOVAL**

REMOVE ROAD WHEELS BY FOLLOWING NUMERICAL SEQUENCE. TAP WITH SOFT HAMMER TO SEPARATE WHEELS.

**INSTALLATION**

ASSEMBLE ROAD WHEELS WITH ITEMS 7, 6, 5, AND 4 FINGER TIGHT. INSTALL ROAD WHEEL ASSEMBLY ON SPINDLE AND TIGHTEN ITEMS 2 AND 1. TIGHTEN 8 NUTS, ITEM 4. REMOVE JACK AND CHOCKS.

WE 66661

Figure 9-61. Removal/installation - road wheels

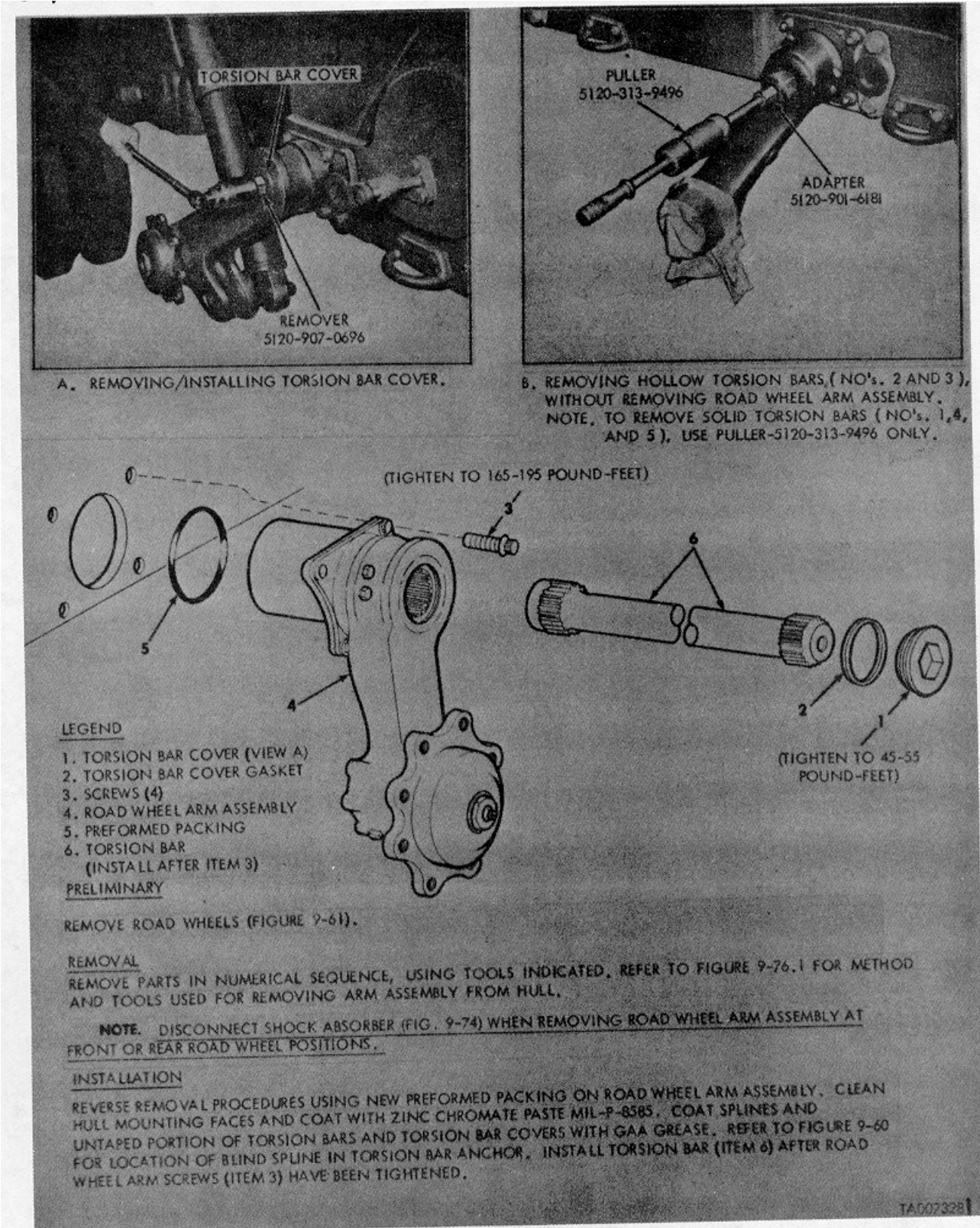
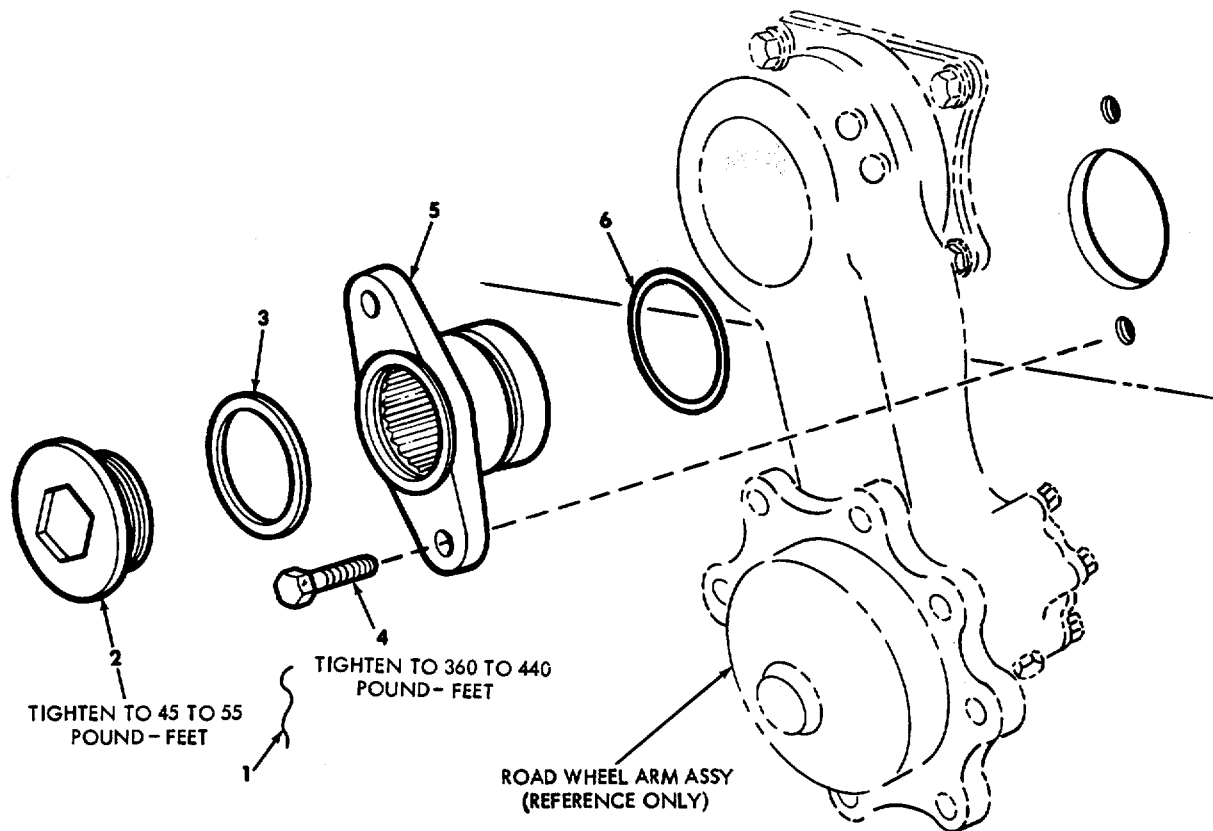

Figure 9-62. Removal/installation - torsion bar and road wheel arm assembly

**LEGEND**

1. LOCK WIRE
2. TORSION BAR ANCHOR COVER
3. TORSION BAR ANCHOR COVER GASKET
4. TORSION BAR ANCHOR SCREWS (2)
5. TORSION BAR ANCHOR
6. PREFORMED PACKING

**PRELIMINARY STEP**

REMOVE ROAD WHEELS (FIG. 9-61).

**NOTE.** TO REMOVE TORSION BAR ANCHORS, REMOVE ROAD WHEELS WHICH OPERATE FROM THE AFFECTED ANCHORS. IN SOME POSITIONS IT IS ALSO NECESSARY TO REMOVE ROAD WHEELS ON ANCHOR SIDE OF VEHICLE (FIG. 9-62).

**REMOVAL**

REMOVE PARTS IN NUMERICAL SEQUENCE, USING REMOVER-5120-999-4055 TO REMOVE TORSION BAR ANCHOR (FIGURE 9-76.1).

**INSTALLATION**

REVERSE REMOVAL PROCEDURE, REFER TO FIG. 9-60 FOR PROPER LOCATION OF BLIND SPLINE IN ANCHOR. CLEAN HULL MOUNTING FACES AND COAT WITH ZINC CHROMATE PASTE MIL-P-8585. INSTALL NEW GASKETS. TAP ANCHOR IN PLACE USING SOFT HAMMER. LIGHTLY COAT THREADS ON COVER WITH GAA GREASE. LOCK WIRE TORSION BAR ANCHOR SCREWS AFTER TIGHTENING.

WE 66663

Figure 9-63. Removal/installation - torsion bar anchors

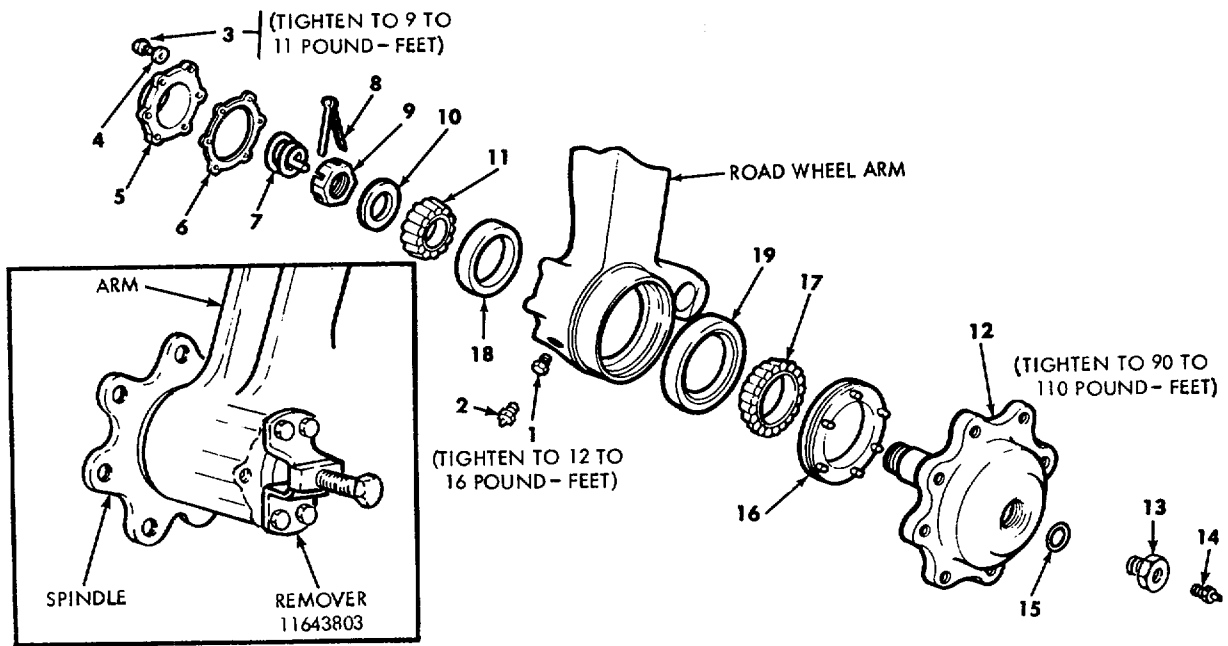

- 1. PLUG
- 2. RELIEF FITTING
- 3. SCREWS (6)
- 4. FLAT WASHERS (6)
- 5. COVER
- 6. GASKET
- 7. SPRING

- 8. COTTER PIN
- 9. SPINDLE NUT
- 10. RETAINING WASHER
- 11. INNER BEARING CONE
- 12. ROADWHEEL SPINDLE
- 13. PLUG
- 14. GREASE FITTING

- 15. PREFORMED PACKING
- 16. SEAL
- 17. OUTER BEARING CONE
- 18. INNER BEARING CUP
- 19. OUTER BEARING CUP

**PRELIMINARY STEP**

REMOVE ROADWHEELS (FIGURE 9-61)

**DISASSEMBLY**

REMOVE PARTS 1 THROUGH 10 IN NUMERICAL SEQUENCE. REMOVE SPINDLE FROM ARM USING REMOVER 11643803 (SEE INSET). REMOVE BALANCE OF PARTS USING METHOD AND TOOL SHOWN ON A, FIGURE 9-76.

**ASSEMBLY**

REVERSE DISASSEMBLY PROCEDURE, AND FOLLOW INSTRUCTIONS LISTED BELOW. USE TOOLS SHOWN BY B, C, D AND E, FIGURE 9-76.

**NOTE.** INSTALL ITEM 16 PER INSTRUCTIONS LISTED ON FIG. 9-75. ALIGN HOLES IN ITEM 12 WITH PINS ON ITEM 16.

**ITEM 9 INSTALL AND ADJUST:**

- a. TIGHTEN NUT TO 100 POUND- FEET.
- b. BACK OFF NUT TO 0, THEN TIGHTEN NUT BY HAND.
- c. STRIKE END OF SPINDLE SHAFT WITH SOFT HAMMER TO RELEASE SET OF BEARINGS OBTAINED AT 100 POUND- FEET.
- d. TIGHTEN NUT TO 25-30 POUND- FEET. A SLOT IN NUT SHOULD BE IN LINE WITH A HOLE IN SPINDLE, IF NECESSARY BACK NUT OFF TO CORRECT, INSTALL COTTER PIN AND BEND OVER.
- e. AFTER ADJUSTMENT, SPINDLE MUST ROTATE AT A TORQUE LESS THAN 10 POUND- FEET.

**LUBRICATION**

HAND PACK WITH GAA GREASE AT ASSEMBLY. AFTER INSTALLATION, LOOSEN COVER (ITEM 5) AND FILL WITH GUN UNTIL GREASE ESCAPES PAST COVER GASKET. THEN TIGHTEN COVER AND FILL UNTIL GREASE ESCAPES FROM RELIEF FITTING (ITEM 2).

WE 66664

Figure 9-64. Disassembly/assembly - road wheel arm spindle

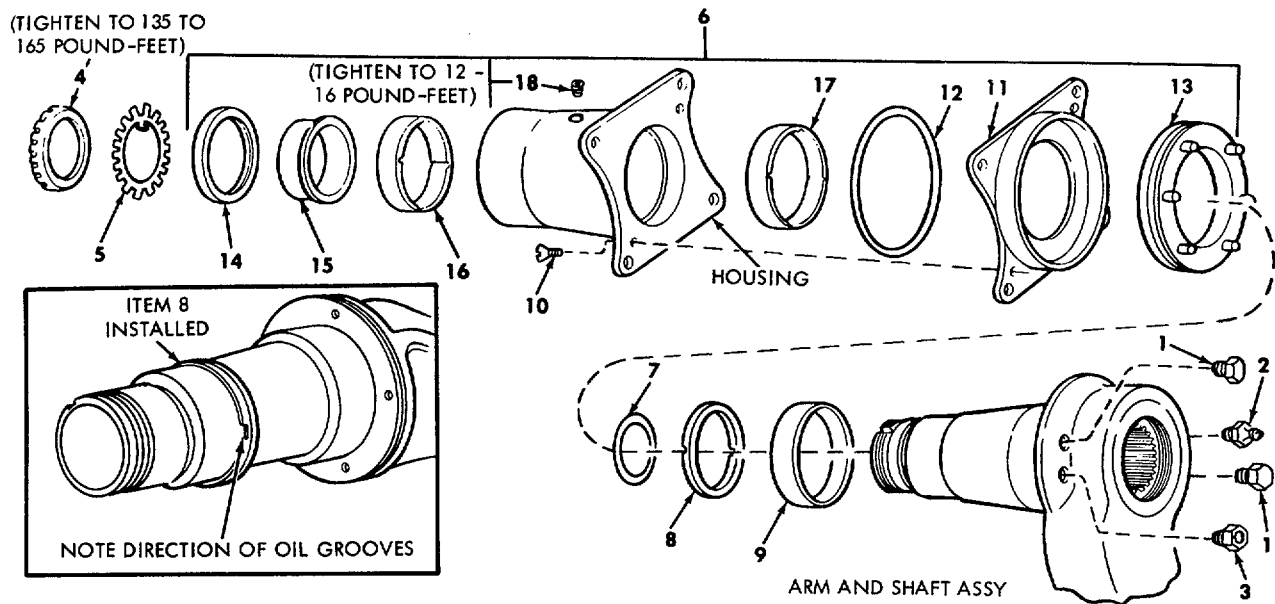
**PRELIMINARY STEP**

REMOVE ROADWHEEL ARM ASSEMBLY FROM VEHICLE (FIG. 9-62).

**DISASSEMBLY AND LEGEND**

1. PLUG (2)
2. GREASE FITTING
3. RELIEF FITTING
4. NUT (PRY UP TAB ON ITEM 5), USE WRENCH 5120-901-4283 (FIG. 9-76).
5. LOCK WASHER
6. HOUSING ASSEMBLY GROUP - SLIDE OFF ARM AND SHAFT ASSEMBLY
7. INNER PREFORMED PACKING
8. THRUST WASHER
9. SLEEVE SPACER
10. FLAT HEAD SCREWS (2)
11. SEAL RETAINER
12. OUTER PREFORMED PACKING
13. OUTER SEAL - USE DRIFT PIN
14. INNER SEAL - DRIVE OUT WITH ITEM 15. USING PUNCH 5120-910-3738 (A, FIG. 9-77).
15. THRUST COLLAR
16. INNER HOUSING BEARING - USE CHISEL IN GROOVE - BREAK OUT.
17. OUTER HOUSING BEARING - **CAUTION: DO NOT DAMAGE THE HOUSING BORES.**
18. PLUG

**ASSEMBLY**

REVERSE DISASSEMBLY NUMERICAL SEQUENCE, FOLLOW INSTRUCTIONS LISTED BELOW.

- 16/17 INSTALL BEARINGS WITH GROOVE IN 12 O'CLOCK POSITION, IN LINE WITH PLUG 18.

- 17 USE REPLACER 5120-906-1059 (B, FIG. 9-77).  
 16/15 USE REPLACER 5120-906-1059 (C, FIG. 9-77).  
 14 USE REPLACER 5120-906-1055 (D, FIG. 9-77).

**NOTE. FOLLOW INSTRUCTIONS GIVEN FIG. 9-75.**

- 13 INSTALL IN ITEM 11 USE REPLACER 5120-906-1057 (E, FIG. 9-77).

**NOTE. FOLLOW INSTRUCTIONS GIVEN FIG. 9-75.**

- 12/11/10 CLEAN MATING FACES, APPLY LIGHT COATING OF GREASE TO ITEM 12 AND INSTALL IN GROOVE ON ITEM 11 SECURE TO HOUSING WITH ITEM 10.

**CAUTION: MAKE SURE ITEM 12 IS PROPERLY LOCATED DURING ASSEMBLY.**

- 9/8/7 INSTALL ITEMS 9, 8 AND 7 ONTO ARM AND SHAFT ASSEMBLY. NOTE DIRECTION OF GROOVES ABOVE. APPLY LIGHT COATING OF GREASE TO OUTSIDE OF ITEM 7 AND THREADED END OF SHAFT. SLIDE ITEM 6 ONTO ARM AND SHAFT ASSEMBLY. ALIGN PINS IN FACE OF ITEM 13 WITH HOLES IN ARM.

- 5/4 INSTALL ITEMS 5 AND 4, TIGHTEN ITEM 4 WITH WRENCH 5120-901-4283 (F, FIG. 9-76). BEND OVER AT LEAST ONE TAB OF ITEM 5 INTO SLOT ON ITEM 4.

- 3/2/1 TIGHTEN TO 12-16 POUND-FEET.

**LUBRICATION**

HAND PACK WITH GAA GREASE AT ASSEMBLY. AFTER INSTALLATION FILL WITH GUN UNTIL GREASE ESCAPES FROM RELIEF FITTING.

WE 66665

Figure 9-65. Disassembly/assembly position no. 2 and no. 3 road wheel arm housing and shaft assembly

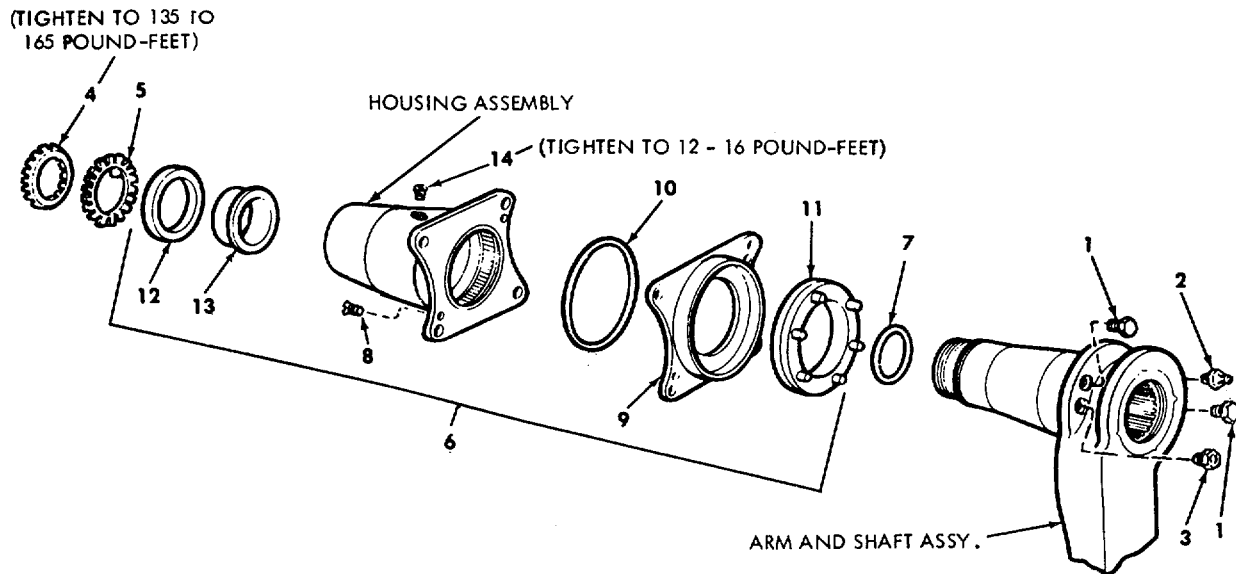

**PRELIMINARY STEP**

REMOVE ROADWHEEL ARM ASSEMBLY (FIG. 9-62).

**DISASSEMBLY**

1. PLUG (2)
2. GREASE FITTING
3. RELIEF FITTING
4. NUT - (PRY UP TABS ON ITEM 5). USE WRENCH 5120-901-4283 (F, FIG. 9-76).
5. LOCK WASHER
6. HOUSING ASSEMBLY GROUP - SLIDE OFF ARM AND SHAFT ASSEMBLY.
7. INNER PREFORMED PACKING - REMOVE FROM ARM AND SHAFT ASSEMBLY.
8. FLAT HEAD SCREWS (2).
9. SEAL RETAINER
10. OUTER PREFORMED PACKING
11. OUTER SEAL - USE PUNCH 5120-910-3738.
12. INNER SEAL - DRIVE OUT WITH ITEM 13 USING PUNCH - 5120-910-3738 (A, FIG. 9-77).
13. THRUST COLLAR
14. PLUG

**ASSEMBLY**

REVERSE DISASSEMBLY PROCEDURE USING FOLLOWING METHOD.

- 13/12 INSTALL, USE REPLACER 5120-906-1055 (D, FIG. 9-77).  
**NOTE:** FOLLOW INSTRUCTIONS (FIG. 9-75).
- 11 INSTALL ITEM 11 INTO ITEM 9. USE REPLACER 5120-906-1057 (E, FIG. 9-77).  
**NOTE:** FOLLOW INSTRUCTIONS (FIG. 9-75).
- 10/9/8 CLEAN MATING FACES, APPLY LIGHT COATING OF GREASE TO ITEM 10 AND INSTALL IN GROOVE ON ITEM 9. SECURE TO HOUSING WITH ITEM 8.  
**CAUTION:** MAKE SURE ITEM 10 IS PROPERLY LOCATED DURING ASSEMBLY.
- 7/6 PLACE ITEM 7 IN GROOVE ON THE ARM AND SHAFT ASSEMBLY. APPLY A LIGHT COATING OF GREASE TO ITEM 7 AND THE THREADED END OF SHAFT. SLIDE ITEM 6 ONTO ARM AND SHAFT ASSEMBLY. PROPERLY ALIGN ITEM 11 PINS WITH HOLES IN ARM AND SHAFT ASSEMBLY.
- 5/4 INSTALL ITEMS 5 AND 4, TIGHTEN ITEM 4 WITH WRENCH 5120-901-4283 (F, FIG. 9-76). BEND OVER AT LEAST ONE TAB OF ITEM 5 INTO SLOT ON ITEM 4.
- 3/2/1 TIGHTEN TO 12-16 POUND-FEET.

**LUBRICATION**

HAND PACK WITH GAA GREASE AT ASSEMBLY. AFTER INSTALLATION FILL WITH GUN UNTIL GREASE ESCAPES FROM RELIEF FITTING.

WE 66666

Figure 9-66. Disassembly/assembly position no. 1, no. 4 and no. 5 road wheel arm housing and shaft assembly

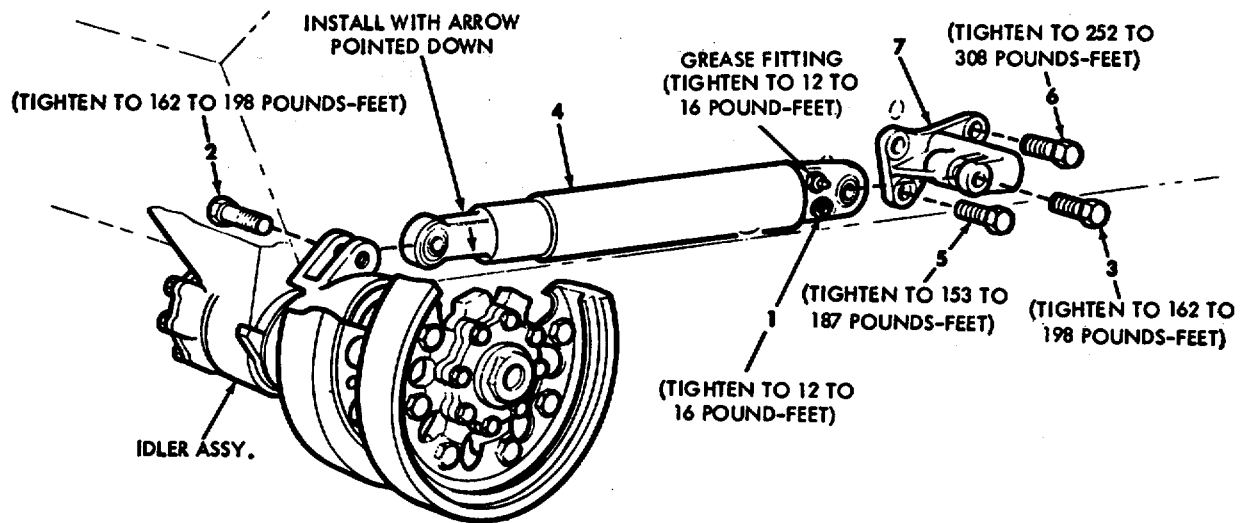
**PRELIMINARY STEPS**

DISCONNECT TRACK (FIG. 5-5).

**REMOVAL**

FOLLOW NUMERICAL SEQUENCE.

1. BLEED PLUG (LOOSEN)
2. SCREW (IDLER END)
3. SCREW (BRACKET END)
4. TRACK HYDRAULIC ADJUSTER
5. SCREW (2) (5/8" DIA.)
6. SCREW (3/4" DIA.)
7. ADJUSTER BRACKET

**INSTALLATION**

REVERSE REMOVAL PROCEDURE. ADJUST TRACK TENSION, FIG. 5-4.

WE 12044

Figure 9-67. Removal/installation - track hydraulic adjuster and bracket

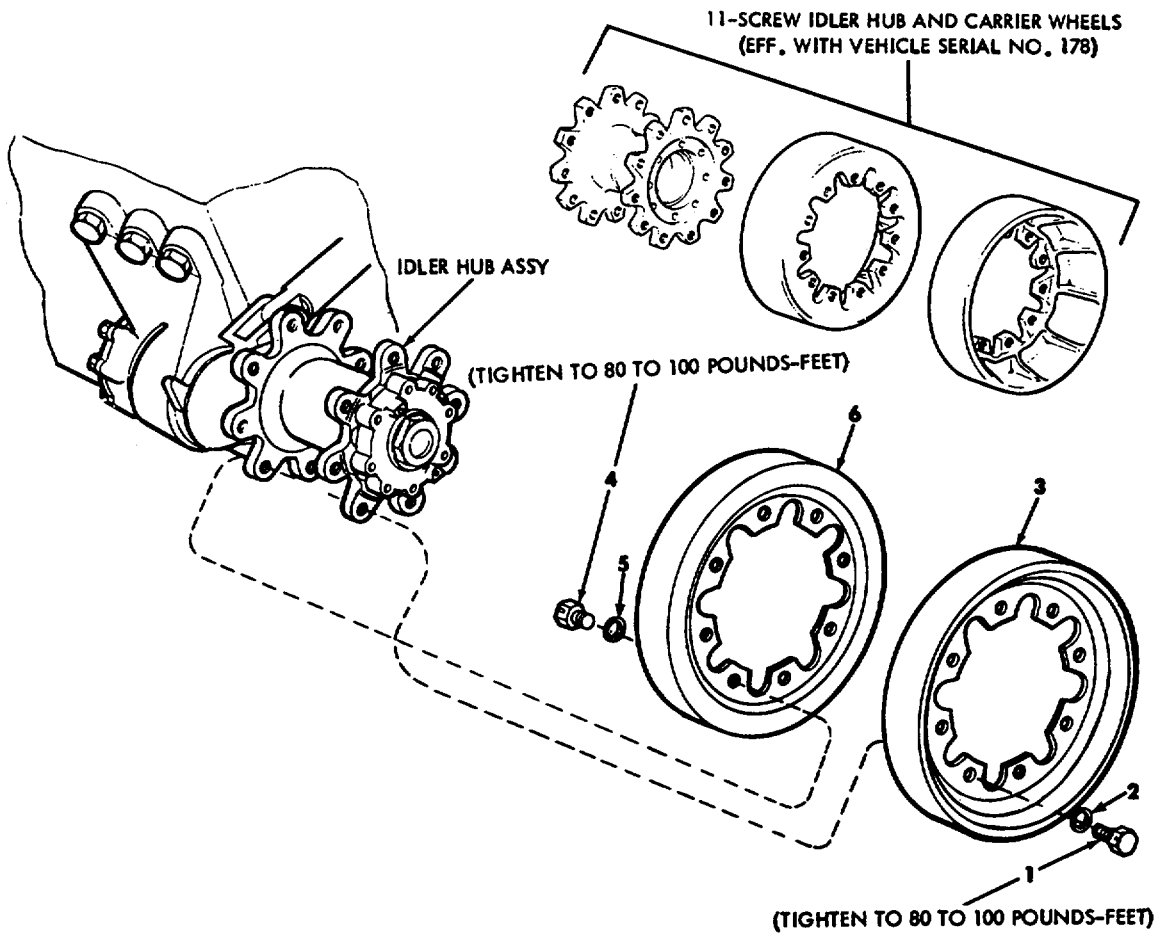

**PRELIMINARY STEPS**

- A. LOOSEN BUT DO NOT REMOVE SCREWS (1) AND (4).
- B. DISCONNECT TRACK (REFER TO FIG. 5-5) AND REMOVE TRACK FROM IDLER WHEELS.

**REMOVAL**

REMOVE COMPONENTS IN NUMERICAL SEQUENCE.

- 1. SCREW (8 OR 11)
- 2. WASHER (8OR 11)
- 3. OUTER IDLER WHEEL
- 4. SCREW (8 OR 11)
- 5. WASHER (8 OR 11)
- 6. INNER IDLER WHEEL

**INSTALLATION**

REVERSE REMOVAL PROCEDURE.

WE 12025

Figure 9-68. Removal/installation - track idler wheels.

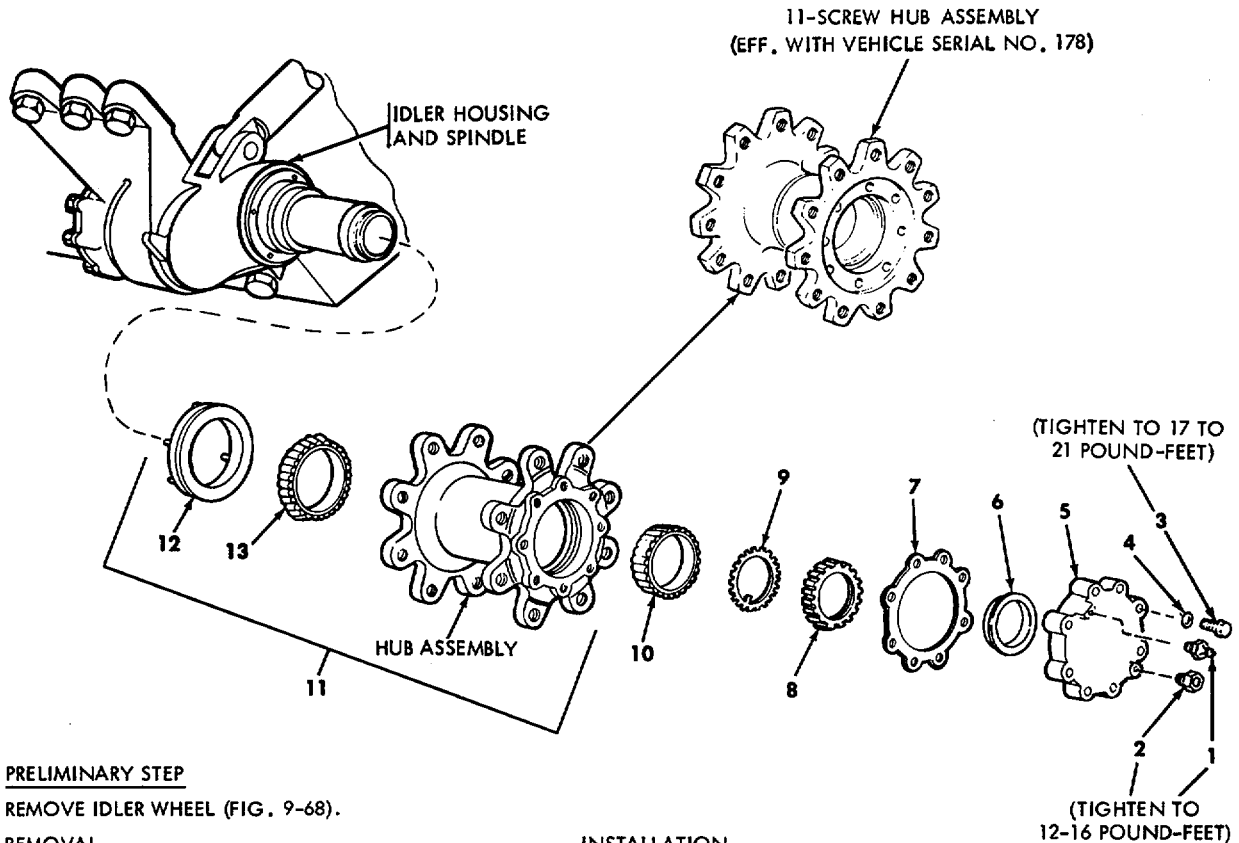

**PRELIMINARY STEP**

REMOVE IDLER WHEEL (FIG. 9-68).

**REMOVAL**

1. GREASE FITTING
2. RELIEF FITTING
3. SCREW (8 OR 11)
4. FLAT WASHER (8 OR 11)
5. HUB CAP
6. COVER
7. GASKET
8. NUT (PRY UP TAB ON ITEM 9. USE WRENCH 5120-901-4282 (A, FIG. 9-78).
9. LOCK WASHER
10. OUTER BEARING CONE - SLIDE OFF WITH ITEM 11.
11. HUB ASSEMBLY WITH BEARINGS AND SEAL
12. SEAL
13. BEARING

**INSTALLATION**

REVERSE DISASSEMBLY PROCEDURE AND FOLLOW INSTRUCTIONS NOTED BELOW.  
 HUB ASSEMBLY - FLUSH AND CLEAN.  
 13/12 INSTALL AND SEAT. USE REPLACER 5120-906-1057 (C, FIG. 9-78).

**NOTE.** FOLLOW INSTRUCTIONS GIVEN ON FIG. 9-75.

- 11 ALIGN PINS ON ITEM 12 WITH HOLES IN SPINDLE.
- 8 TIGHTEN, USE WRENCH 5120-901-4282 (A, FIG. 9-78).

**NUT ADJUSTMENT**

- a. TIGHTEN NUT TO 50 POUND-FEET, BACK OFF TO ZERO (0) AND ROTATE HUB.
- b. TIGHTEN NUT TO 10 POUNDS-FEET WHILE ROTATING HUB, AND BEND TAB ON LOCK WASHER (9) INTO NUT SLOT.

**LUBRICATION**

HAND PACK WITH GAA GREASE AT ASSEMBLY. AFTER INSTALLATION FILL WITH GUN UNTIL GREASE ESCAPES FROM RELIEF FITTING.

WE 66669

Figure 9-69. Removal/installation - idler hub assembly

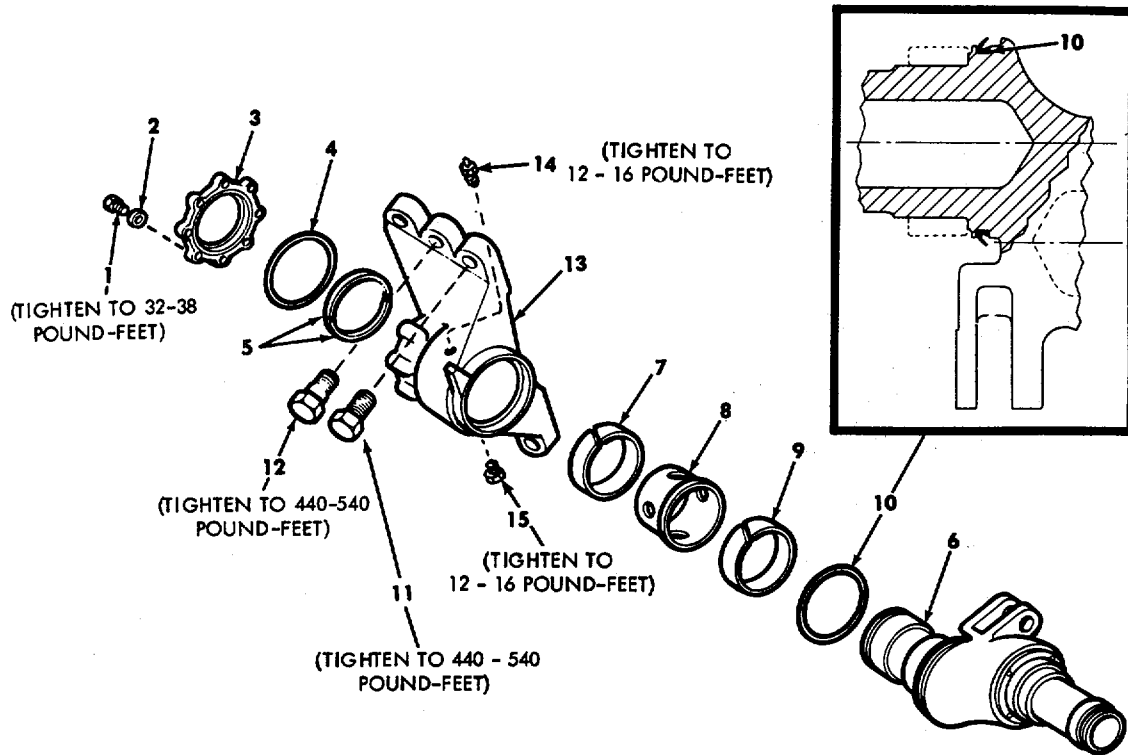

**LEGEND**

- |                            |                                     |
|----------------------------|-------------------------------------|
| 1. SCREW (8)               | 8. BEARING SPACER                   |
| 2. FLAT WASHER (8)         | 9. OUTER BEARING                    |
| 3. CAP                     | 10. PREFORMED OUTER PACKING         |
| 4. PREFORMED INNER PACKING | 11. SCREW (4) (3" LONG)             |
| 5. RETAINER (SPLIT TYPE)   | 12. SHOULDER BOLT (2) (3-1/8" LONG) |
| 6. SPINDLE                 | 13. IDLER HOUSING                   |
| 7. INNER BEARING           | 14. GREASE FITTING                  |
|                            | 15. RELIEF FITTING                  |
- INSTALLED ON SOME LATE PRODUCTION VEHICLES. INSTALLED AT REBUILD ON EARLIER VEHICLES

**PRELIMINARY STEPS**

- A. REMOVE IDLER WHEELS AND HUB ASSEMBLY (FIGS. 9-68 AND 9-69).
- B. DISCONNECT TRACK HYDRAULIC ADJUSTER AT IDLER SPINDLE BRACKET (FIG. 9-67).

**REMOVAL/DISASSEMBLY**

REMOVE AND DISASSEMBLE IDLER ASSEMBLY BY FOLLOWING NUMERICAL SEQUENCE. SUPPORT HOUSING DURING REMOVAL OF ITEM 12.

**ASSEMBLY/INSTALLATION**

ASSEMBLE COMPONENTS TO HOUSING BY REVERSING DISASSEMBLY PROCEDURE. INSTALL ITEM 10 WITH LIP OF SEAL TOWARD HUB OF SPINDLE AS SHOWN IN INSET. HAND PACK ITEMS 7, 8, 9, AND 13 WITH GAA GREASE. CLEAN MOUNTING FACES OF HULL AND HOUSING (13) AND COAT WITH ZINC CHROMATE PASTE (MIL-P-8585). INSTALL SHOULDER BOLTS (12) AT BOTH LOCATIONS BEFORE TIGHTENING. THESE BOLTS MUST BE TIGHTENED BEFORE TIGHTENING THE OTHER FOUR SCREWS (11).

**LUBRICATION**

AFTER INSTALLATION, ON VEHICLES PROVIDED WITH GREASE FITTINGS (ITEMS 14 AND 15), FILL WITH GAA GREASE USING GUN UNTIL GREASE ESCAPES FROM RELIEF FITTING.

WE 66670

Figure 9-70. Removal/disassembly/assembly/installation - idler housing and spindle assembly

PRELIMINARY STEP

IF VEHICLE IS OPERABLE, START AND MOVE VEHICLE ENOUGH TO ALLOW IT TO COAST TO A STOP

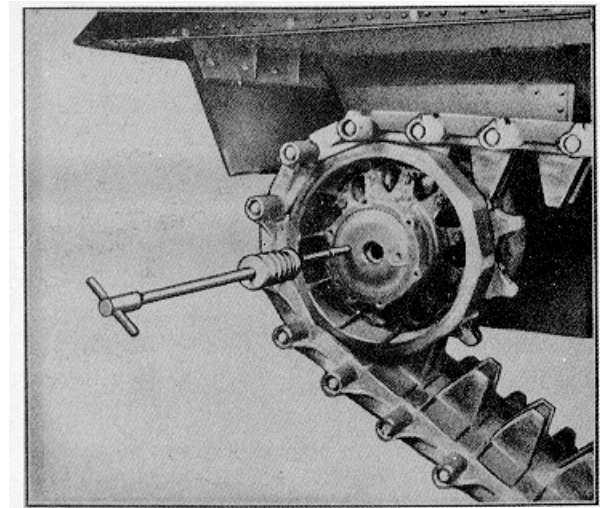
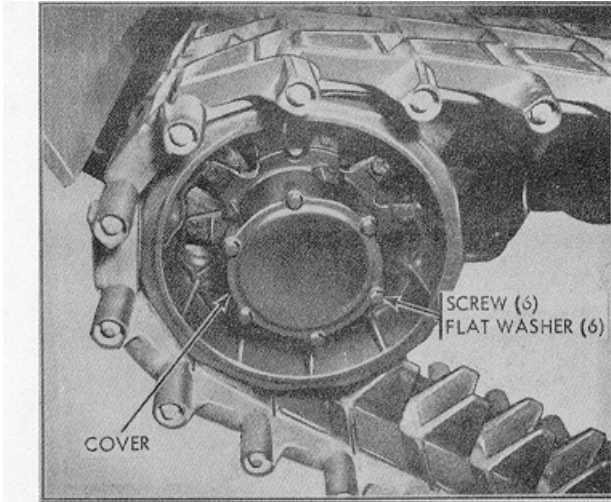

A. REMOVE SCREWS, FLAT WASHERS, COVER, AND SPRING.

REMOVAL

USE PULLER 5120-313-9496 TO REMOVE DRIVE SHAFT.

INSTALLATION

APPLY A LIGHT COAT OF GAA GREASE TO SPLINES ON BOTH ENDS OF SHAFT BEFORE INSTALLATION. APPLY A LIGHT COATING OF NON-HARDENING GASKET MATERIAL, (MIL-S-45180 TYPE 2) TO CONTACT SURFACE OF COVER PLATE.

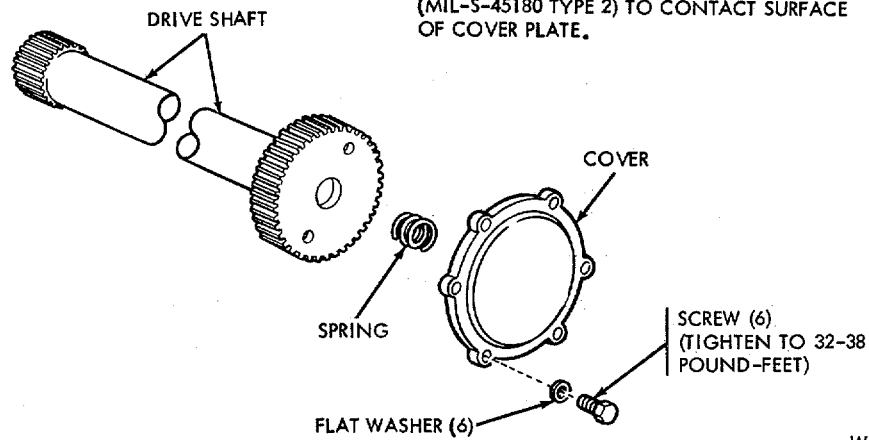

WE 66671

Figure 9-71. Removal/installation - sprocket drive shaft

**NOTE.** THE FOLLOWING INSTRUCTIONS ARE STAMPED ON SPROCKET WEAR GAGE - 5210-906-3706:

(SPROCKET WEAR GAGE FOR SPROCKET 10948438)  
 PLACE GAGE BETWEEN SPROCKET TEETH. REVERSE SPROCKETS WHEN WEAR ON DRIVE SIDE IS 1/8 INCH. REVERSE AGAIN WHEN WEAR IS 1/4 ON DRIVE SIDE. REVERSE AGAIN WHEN TOTAL WEAR ON DRIVE SIDE IS 3/8 INCH. REPLACE SPROCKET WHEN WEAR IS 3/8 INCH ON BOTH SIDES OF TOOTH.

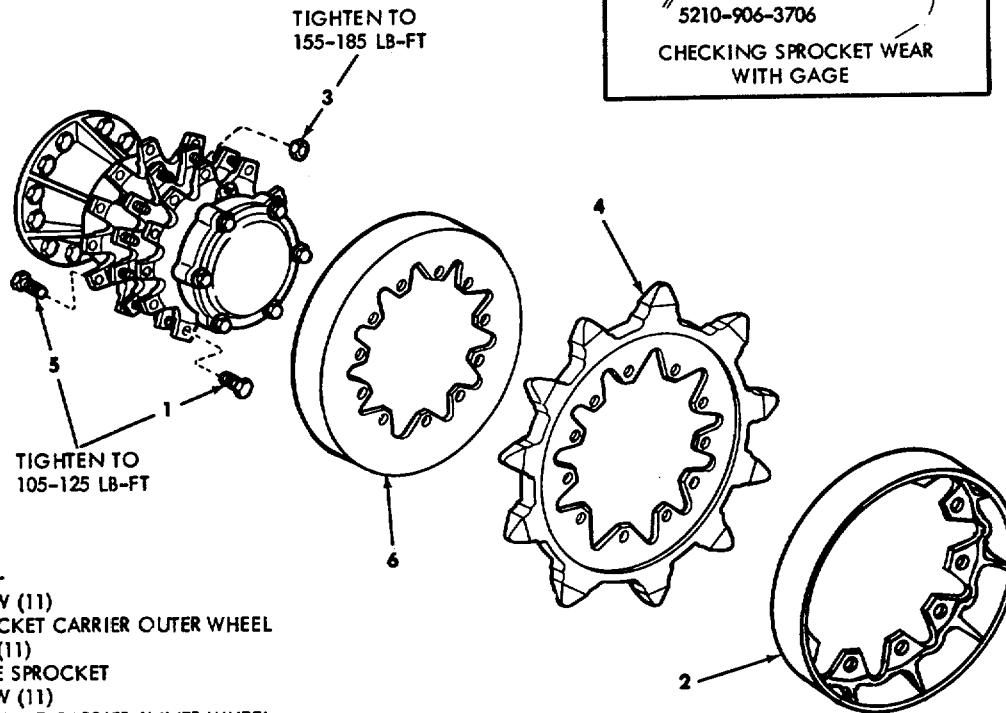
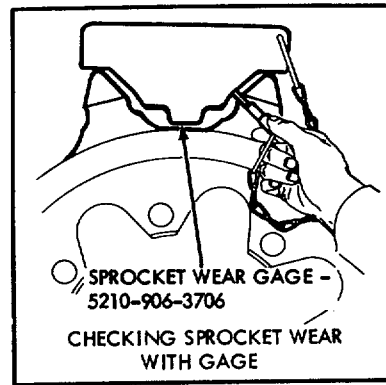

**LEGEND**

- 1. SCREW (11)
- 2. SPROCKET CARRIER OUTER WHEEL
- 3. NUT (11)
- 4. DRIVE SPROCKET
- 5. SCREW (11)
- 6. SPROCKET CARRIER INNER WHEEL

**NOTE.** CARRIER WHEELS SHOULD BE CHANGED WHEN WORN TO THICKNESS OF 1/8 INCH, MEASURED AT A POINT 1-1/2 INCHES FROM OUTER RIM.

**PRELIMINARY STEPS**

DISCONNECT TRACK (FIG. 5-5) AND REMOVE TRACK FROM DRIVE SPROCKET AND SPROCKET CARRIER WHEELS.

**REMOVAL**

REMOVE DRIVE SPROCKET AND CARRIER WHEELS BY FOLLOWING NUMERICAL SEQUENCE.

**INSTALLATION**

REVERSE REMOVAL PROCEDURE. AT 1500 MILES, OR AT SECOND SPROCKET REVERSAL (WHICHEVER OCCURS FIRST), REVERSE THE POSITION OF THE SPROCKET CARRIER WHEELS. PLACE OUTBOARD WHEELS INBOARD, AND INBOARD WHEELS OUTBOARD.

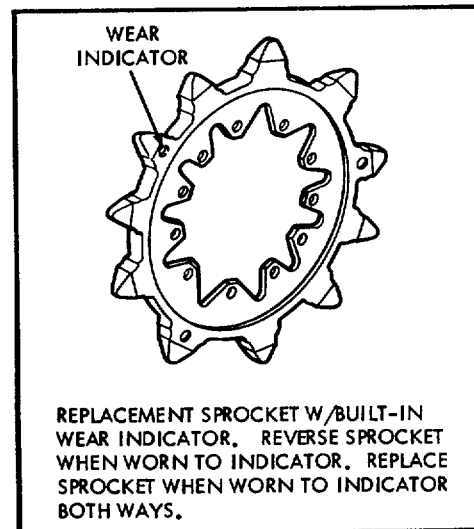

WE 66609

Figure 9-72. Removal/installation - sprocket and sprocket career wheels

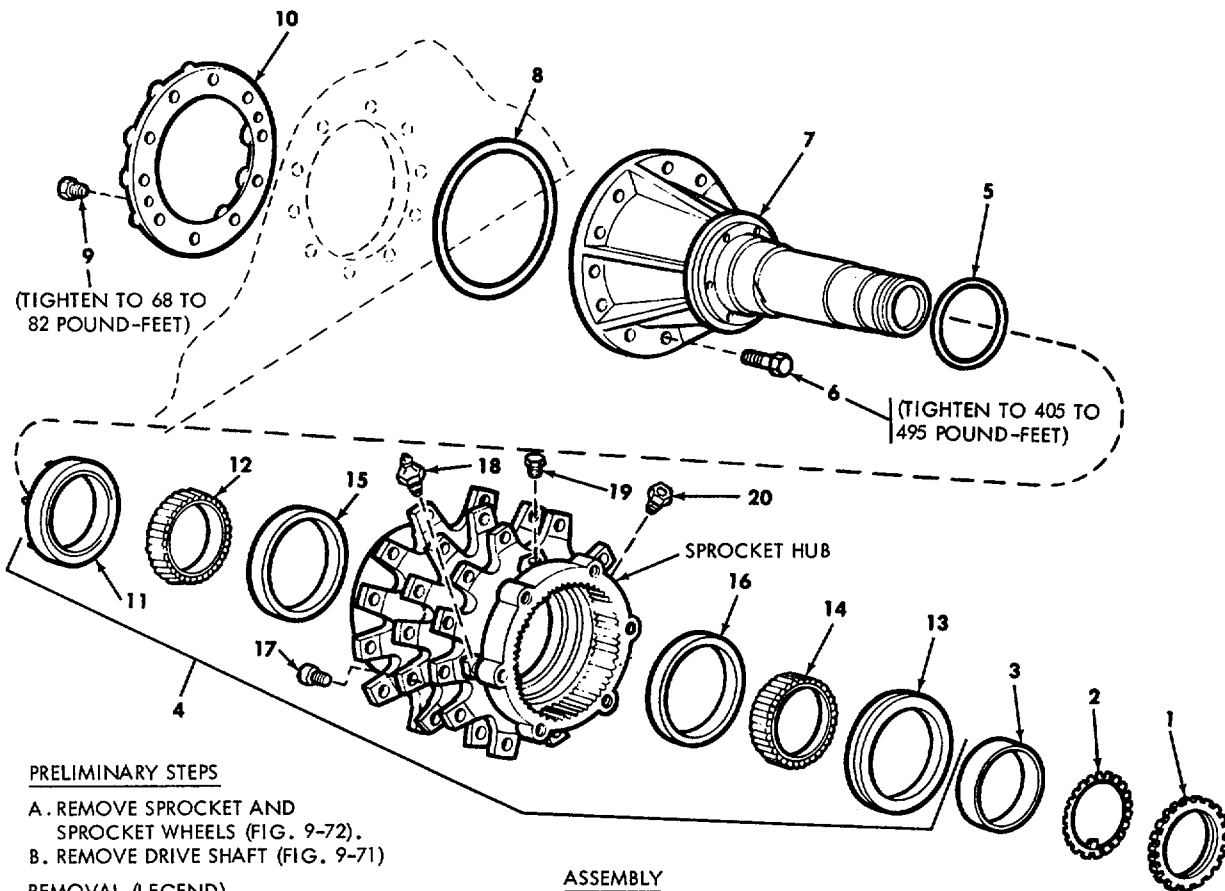
**PRELIMINARY STEPS**

- A. REMOVE SPROCKET AND SPROCKET WHEELS (FIG. 9-72).
- B. REMOVE DRIVE SHAFT (FIG. 9-71)

**REMOVAL (LEGEND)**

1. NUT - (PRY UP TAB ON LOCK WASHER).  
USE WRENCH 5120-901-4294 (D, FIG. 9-78)
2. LOCK WASHER
3. SPACER SLEEVE
4. HUB ASSEMBLY WITH SEALS
5. OUTER PREFORMED PACKING
6. SCREW (10)
7. SPROCKET SUPPORT
8. INNER PREFORMED PACKING
9. SCREWS (2) - OPEN POWER PLANT COMPARTMENT GRILLES.
10. TAPPING RING

**DISASSEMBLY (LEGEND)**

11. INNER SEAL - DRIVE OUT WITH ITEM 12 (A, FIG. 9-79).
12. INNER BEARING CONE
13. OUTER SEAL - DRIVE OUT WITH ITEM 15 (B, FIG. 9-79)
14. OUTER BEARING CONE
15. INNER BEARING CUP - USE DRIFT PIN
16. OUTER BEARING CUP - USE DRIFT PIN
17. SPROCKET MOUNTING SCREWS (11)-  
DRIVE OUT IF NECESSARY.
18. GREASE FITTING
19. PLUG
20. RELIEF FITTING

**ASSEMBLY**

REVERSE DISASSEMBLY PROCEDURE AND FOLLOW INSTRUCTIONS LISTED BELOW.

SPROCKET HUB - FLUSH AND CLEAN OUT.

20/19/18 TIGHTEN TO 12-16 POUND-FEET.

17 INSTALL MAKING SURE SCREW HEADS ARE PROPERLY SEATED IN SPROCKET HUB LUG.

16 SEAT WITH REPLACER 5120-906-1063 (C, FIG. 9-79).

15 SEAT WITH REPLACER 5120-906-1062 (D, FIG. 9-79).

14/13 SEAT WITH REPLACER 5120-906-1057 (E, FIG. 9-79).

**NOTE.** REFER TO INSTRUCTIONS ON FIG. 9-75.

12/11 SEAT WITH REPLACER 5120-906-1056 (F, FIG. 9-79).

**NOTE.** REFER TO INSTRUCTION ON FIG. 9-75.

**INSTALLATION**

INSTALL SPROCKET SUPPORT AND HUB ASSEMBLY BY REVERSING REMOVAL PROCEDURES (STEP 10 THROUGH 1). CLEAN ALL MOUNTING FACES AND COAT WITH ZINC CHROMATE PASTE MIL-P-8585. INSTALL NEW PACKING AT INSTALLATION. ALIGN PINS ON ITEM 11 WITH HOLES IN ITEM 7 DURING ASSEMBLY. TIGHTEN BEARING NUT ITEM 1 TO 50 POUND-FEET TO SEAT BEARING, BACK OFF TO 0 THEN RETIGHTEN TO 10 POUND-FEET. BEND AT LEAST ONE TAB OF ITEM 2 INTO SLOT OF ITEM 1.

**LUBRICATION**

HAND PACK WITH GAA GREASE AT ASSEMBLY. AFTER INSTALLATION FILL WITH GUN UNTIL GREASE ESCAPES FROM RELIEF FITTING.

WE 66673

Figure 9-73. Removal/disassembly/assembly/installation sprocket hub and support



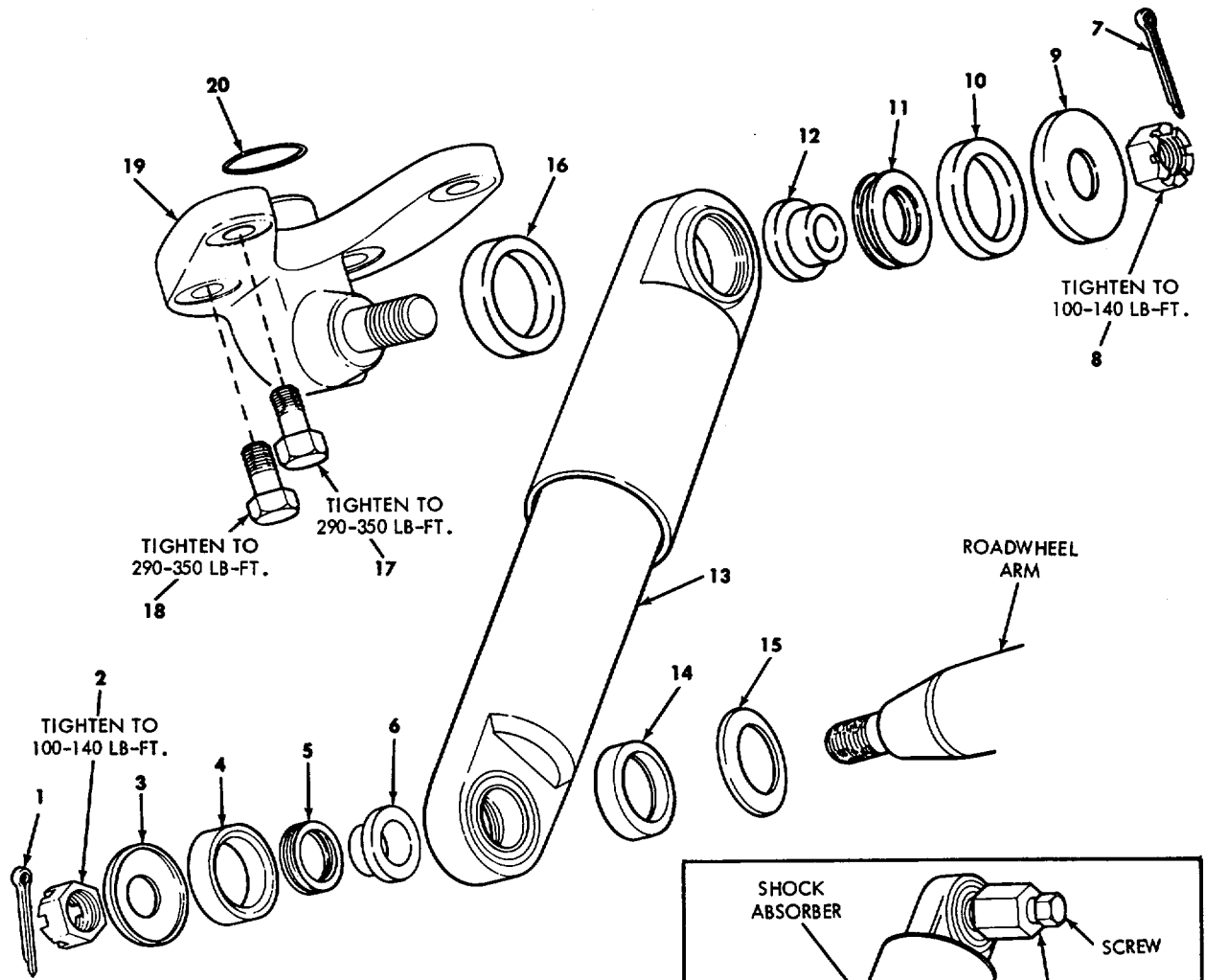

**LEGEND**

- |                       |                          |
|-----------------------|--------------------------|
| 1. COTTER PIN         | 11. CUSHION WASHER       |
| 2. NUT                | 12. SPACER               |
| 3. COVER (25/32 HOLE) | 13. SHOCK ABSORBER       |
| 4. SEAL               | 14. SEAL                 |
| 5. CUSHION WASHER     | 15. COVER (1-7/8 HOLE)   |
| 6. SPACER             | 16. SEAL                 |
| 7. COTTER PIN         | 17. SCREW (2) 2" LG.     |
| 8. NUT                | 18. SCREW (2) 2-1/4" LG. |
| 9. COVER (25/32 HOLE) | 19. BRACKET              |
| 10. SEAL              | 20. PREFORMED PACKING    |

SHOCK ABSORBER

SCREW

REMOVER

SCREW REMOVER - 5120-907-0696 INTO THREADED END OF SHOCK ABSORBER BEARING. HOLD REMOVER WITH WRENCH AND TIGHTEN SCREW TO PULL SHOCK ABSORBER FROM MOUNTING BRACKET OR ROAD WHEEL ARM.

**REMOVAL**

REMOVE BY FOLLOWING NUMERICAL SEQUENCE. USE TOOL 5120-907-0696 AS SHOWN TO DISENGAGE SHOCK ABSORBER FROM SPINDLES.

**INSTALLATION**

REVERSE REMOVAL PROCEDURE. CLEAN HULL MOUNTING FACES AND COAT WITH ZINC CHROMATE PASTE MIL-P-8585 INSTALL NEW SEALS AND PACKING IF REMOVED.

WE 66674

Figure 9-74. Removal/installation - shock absorber and mounting bracket

INSTALLATION PROCEDURE FOR PRESSED IN SHELL, ENCASED SEALS OR LEAKPROOF PARTS

1. WIPE MATING SURFACES (O.D. OF SEAL, I.D. OF HOUSING BORE) FREE OF FOREIGN MATERIAL
2. APPLY SEALING COMPOUND MIL-S-45180, TYPE 3 (NON-HARDENING GASKET COMPOUND) IN A CONTINUOUS COATING AROUND SURFACE OF HOUSING BORE. DO NOT APPLY SEALER TO O.D. OF SEAL. WIDTH "W" SHOULD BE 1/6 TO 1/3 DEPTH OF HOUSING BORE "D". THE WIDTH "W" SHOULD BE CENTERED IN THE HOUSING BORE BUT NOT LOCATED CLOSER THAN 1/8" TO ITS LEADING EDGE. THICKNESS OF SEALER COAT SHOULD BE A MAXIMUM OF 1/2 THE WIDTH "W" BUT NOT LESS THAN 1/64 INCH.
3. INSTALL SEAL WITH SPECIAL TOOL KEEPING SURFACE "X" SQUARE WITH CENTERLINE OF HOUSING BORE.
4. PREVENT SEALER SEEPAGE FROM REACHING EDGE OF SEAL HOUSING "X".

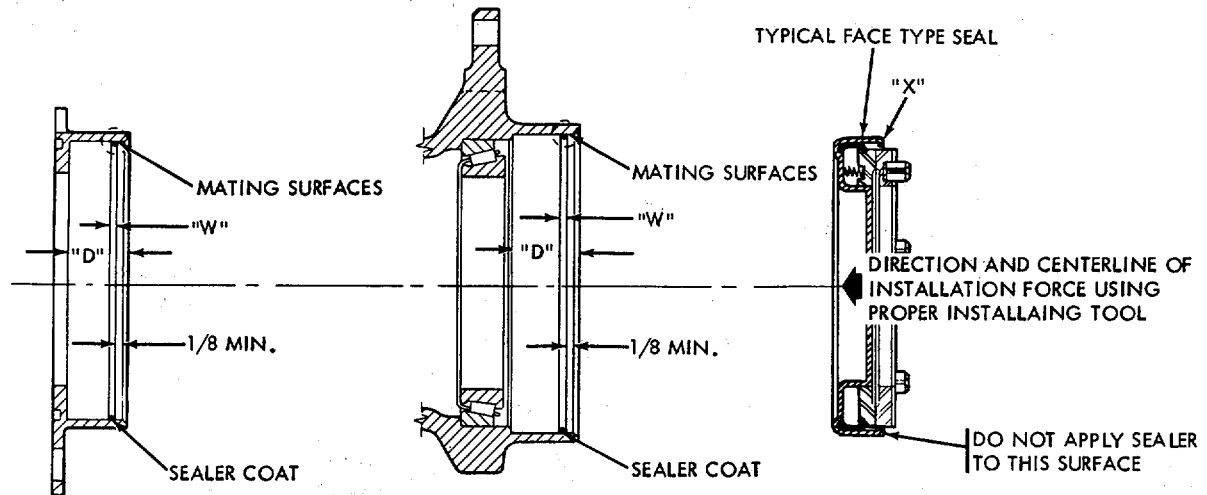

ROAD WHEEL HOUSING OUTER SEAL (FIGS. 9-65 AND 9-66)

IDLER HUB (FIG. 9-69) AND SPROCKET HUB (FIG. 9-73) INNER SEAL

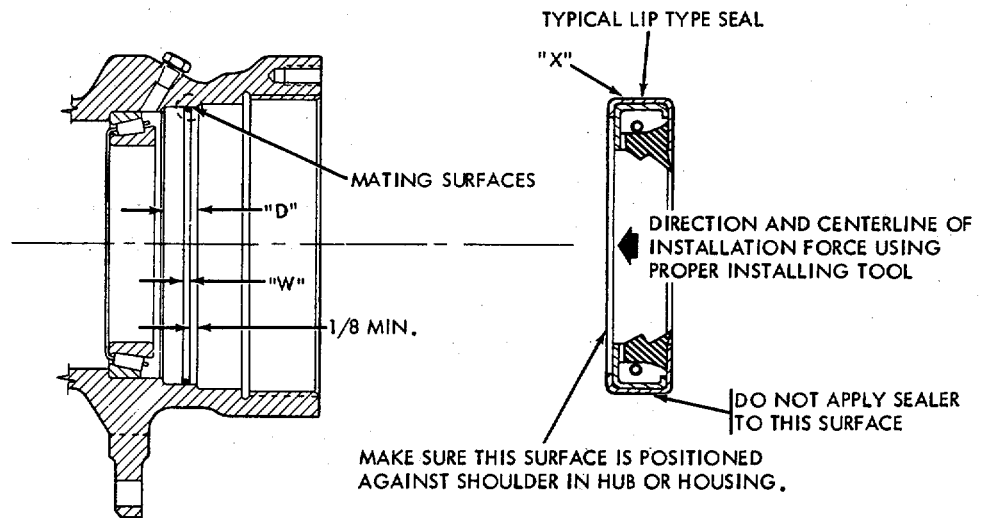

SPROCKET HUB (FIG. 9-73) OUTER SEAL (ALSO HOUSING INNER SEAL (FIGS. 9-65 AND 9-66)

WE 66675

Figure 9-75. Suspension system seal installation specifications

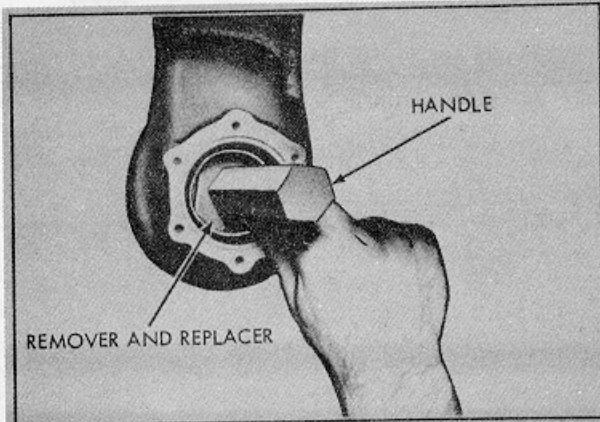

A. REMOVING ROAD WHEEL ARM HUB OUTER BEARING CONE AND OIL SEAL USING REMOVER AND REPLACER - 5120-906-1060 WITH HANDLE - 5120-034-0884.

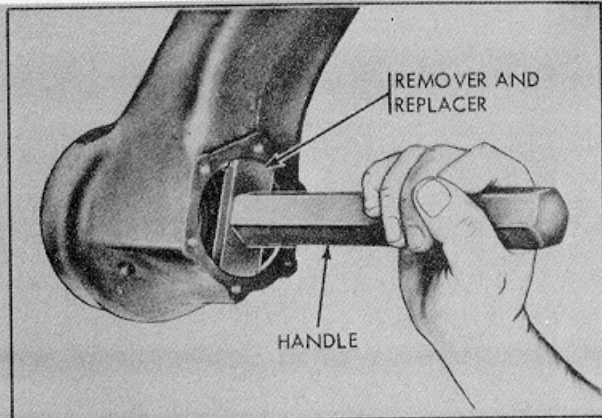

B. INSTALLING ROAD WHEEL ARM HUB INNER BEARING CUP USING REMOVER AND REPLACER - 5120-906-1060 WITH HANDLE - 5120-034-0884.

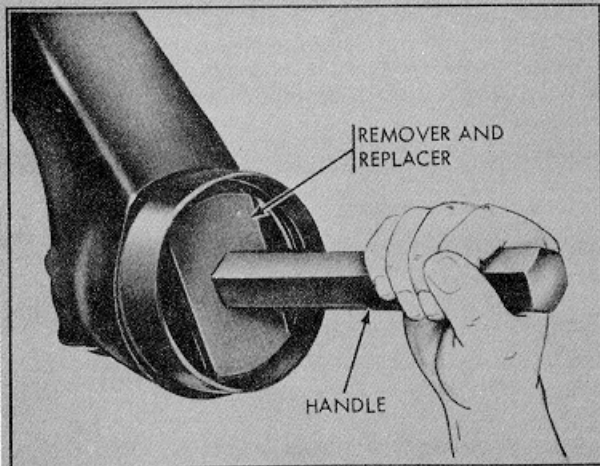

C. INSTALLING ROAD WHEEL ARM HUB OUTER BEARING CUP USING REMOVER AND REPLACER - 5120-906-1061 WITH HANDLE - 5120-034-0884.

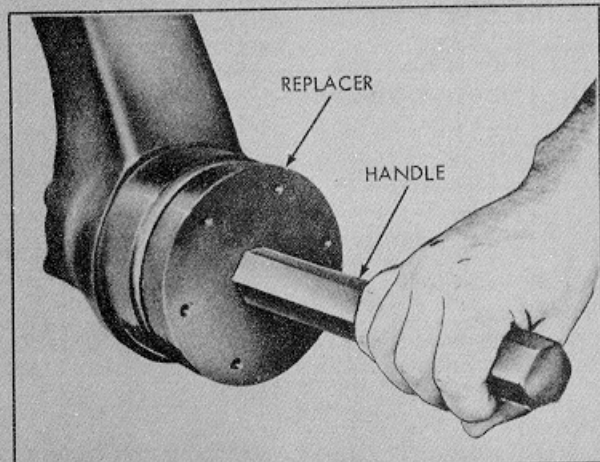

D. INSTALLING ROAD WHEEL ARM HUB OUTER OIL SEAL USING REPLACER - 5120-906-1054 WITH HANDLE - 5120-034-0884.

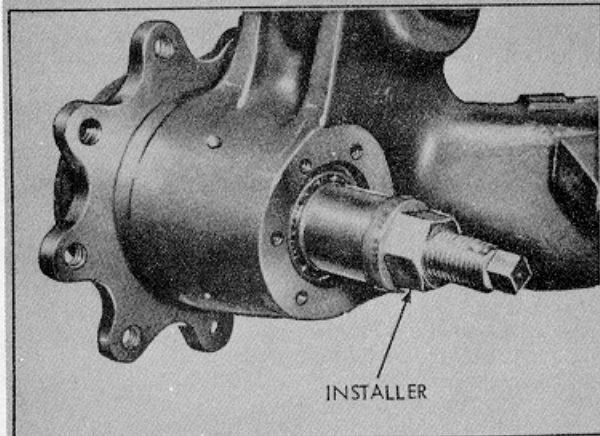

E. INSTALLING ROAD WHEEL ARM SPINDLE INNER BEARING CONE USING INSTALLER - 5120-906-1064.

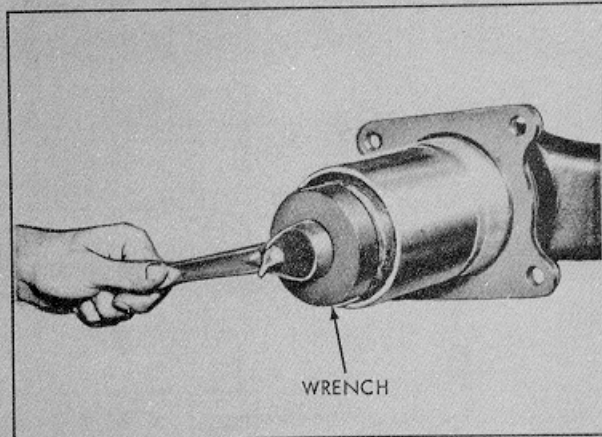

F. REMOVING/INSTALLING ROAD WHEEL ARM SUPPORT HOUSING LOCK NUT USING WRENCH - 5120-901-4283.

WE 11014

Figure 9-76. Suspension system special tools (1 of 4)

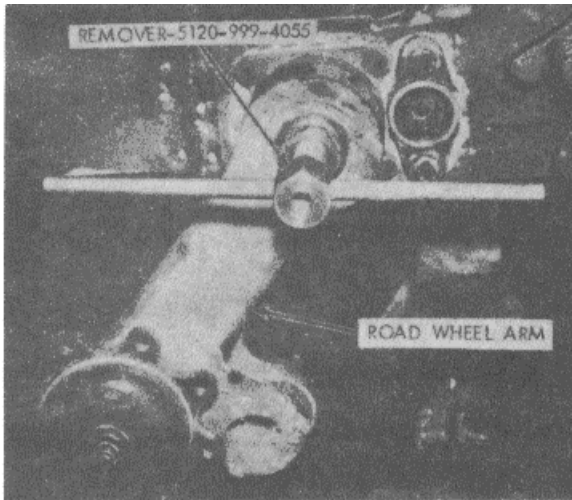

A. REMOVING ROAD WHEEL ARM USING  
REMOVER - 5120-999-4055 WITH TORSION  
BAR INSTALLED. (USE WITH TORSION  
BAR ANCHOR AND COVER INSTALLED).

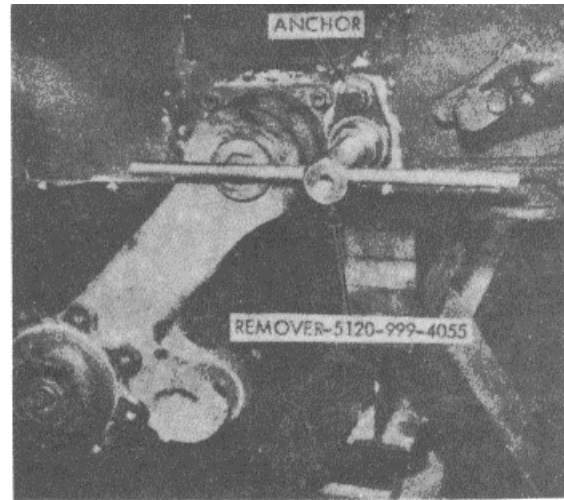

B. REMOVING ROAD WHEEL ARM USING  
REMOVER - 5120-999-4055 INSTALLED  
IN TORSION BAR ANCHOR ON OPPOSITE  
SIDE OF VEHICLE. (REMOVE ROAD WHEEL  
ARM SCREWS (4) BUT DO NOT REMOVE  
TORSION BAR COVER IN ARM).

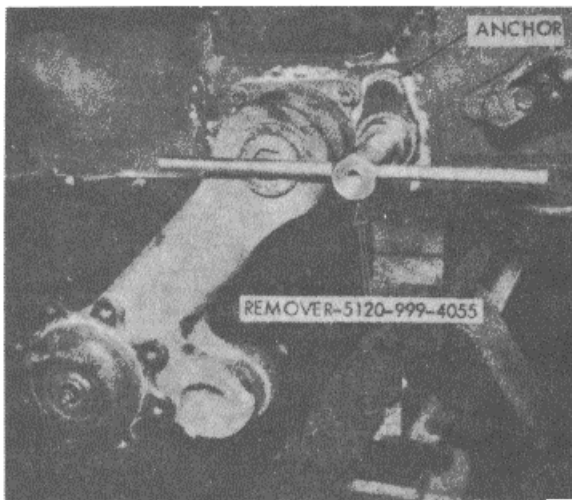

C. REMOVING TORSION BAR ANCHOR USING  
REMOVER - 5120-999-4055. (ROAD WHEEL  
ARM AND TORSION BAR INSTALLED).

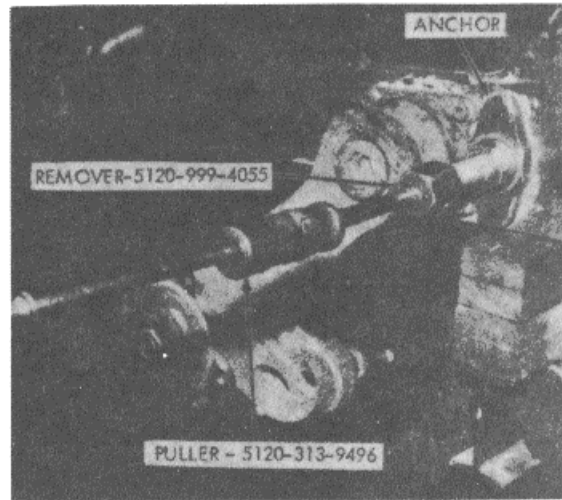

D. REMOVING TORSION BAR ANCHOR USING  
REMOVER - 5120-999-4055 AND PULLER -  
5120-313-9496. (TORSION BAR REMOVED).

Figure 9-76. 1. Suspension system special tools (1.1 of 4),

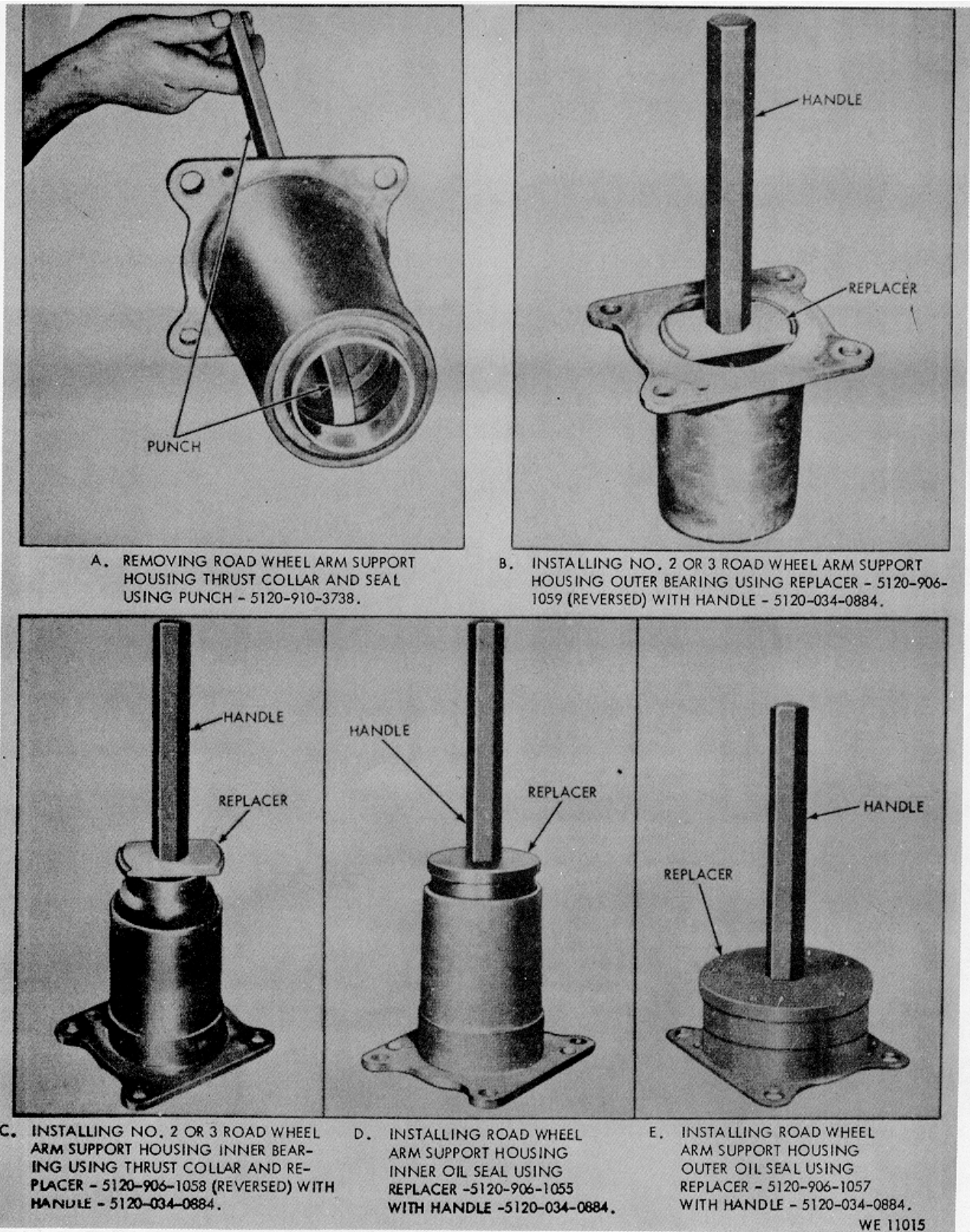
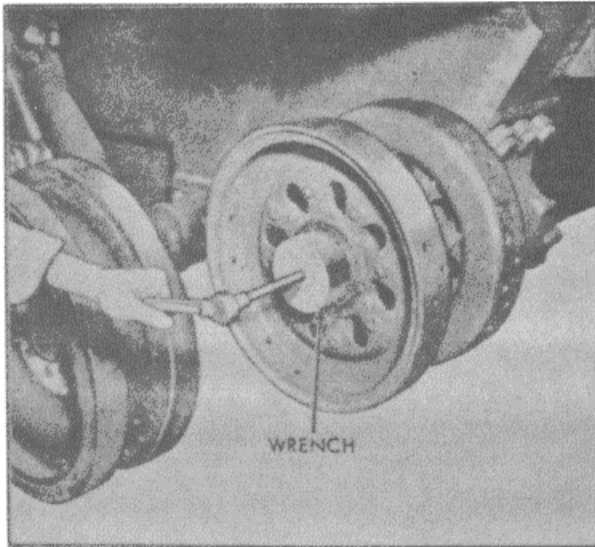
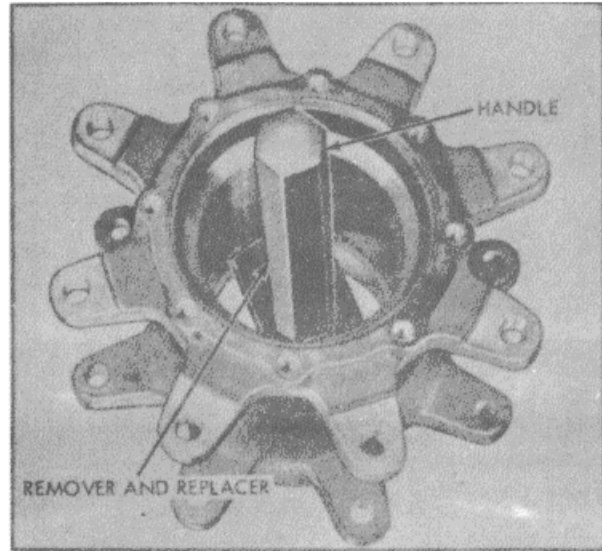

Figure 9-77. suspension system Special tools (2 of 4)





A. REMOVING/INSTALLING IDLER NUT USING WRENCH - 5120-901-4282.



B. REMOVING IDLER HUB INNER BEARING CONE AND OIL SEAL USING REMOVER AND REPLACER - 5120-906-1059 WITH HANDLE - 5120-034-0884.

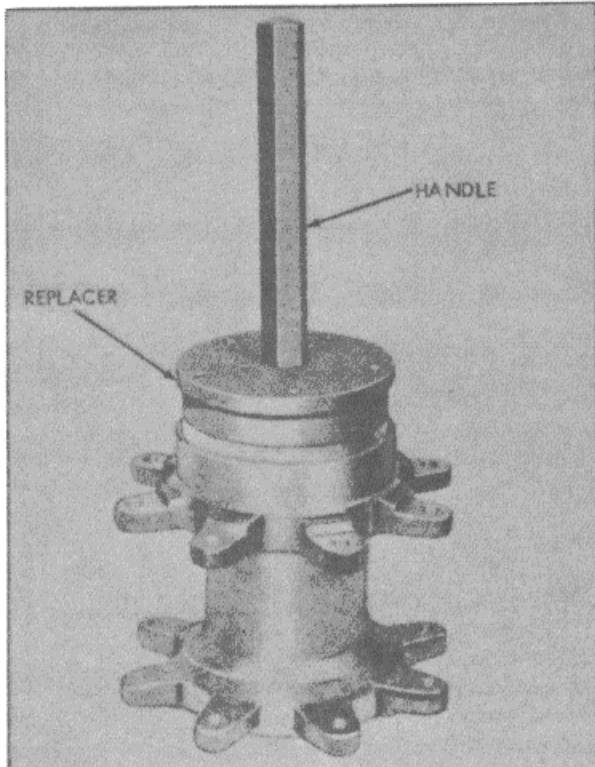

C. INSTALLING IDLER HUB OIL SEAL USING REPLACER - 5120-906-1057 WITH HANDLE - 5120-034-0884.

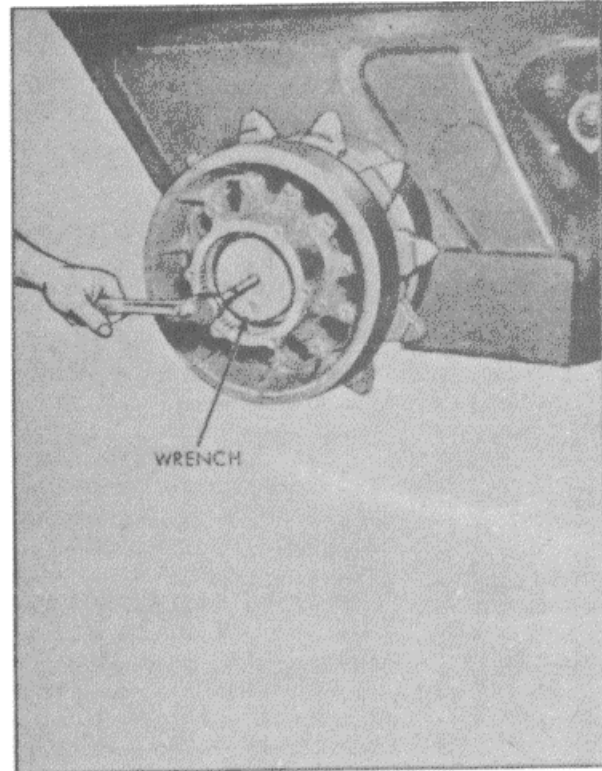

D. REMOVING/INSTALLING SPROCKET HUB NUT USING WRENCH - 5120-901-4294.

Figure 9-78. Suspension system special tools (3 of 4)

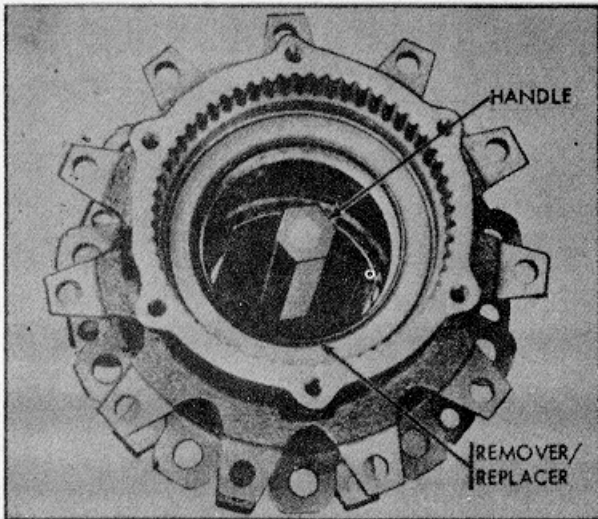

A. REMOVING SPROCKET HUB INNER OIL SEAL AND INNER BEARING CONE USING REMOVER AND REPLACER - 5120-906-1058 WITH HANDLE - 5120-034-0884.

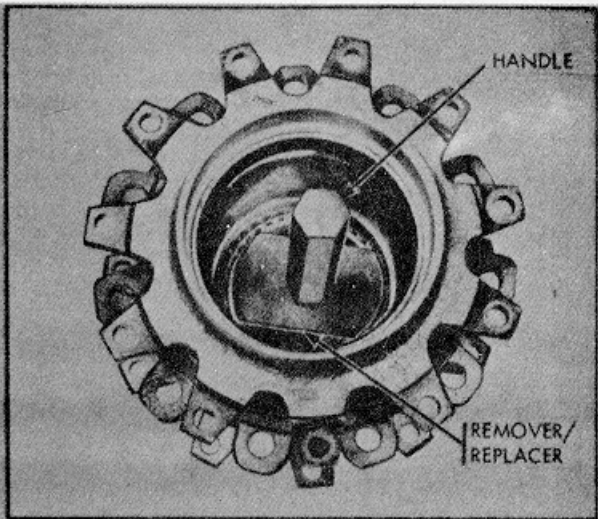

B. REMOVING SPROCKET HUB OUTER OIL SEAL AND BEARING CONE USING REMOVER AND REPLACER - 5120-906-1061 WITH HANDLE - 5120-034-0884.

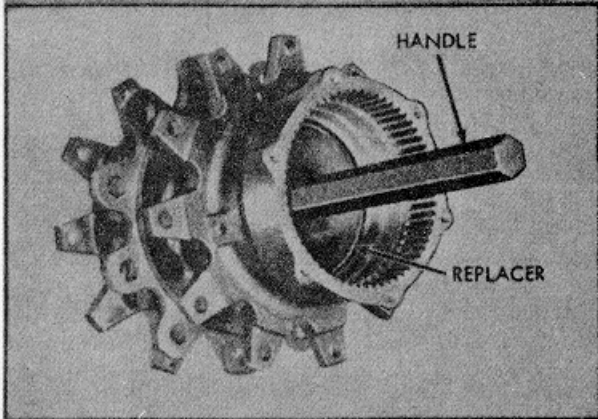

C. INSTALLING SPROCKET HUB OUTER BEARING CUP USING REPLACER - 5120-906-1063 WITH HANDLE - 5120-034-0884.

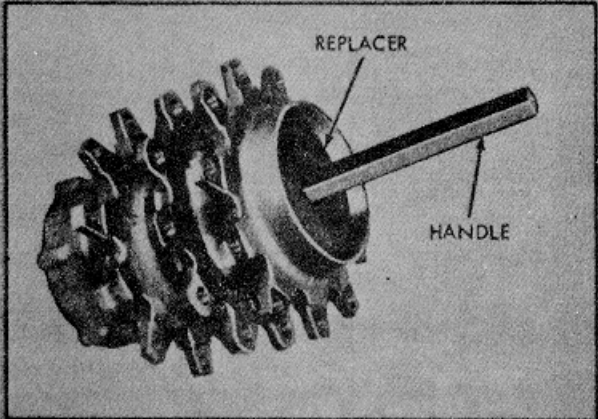

D. INSTALLING SPROCKET HUB INNER BEARING CUP USING REPLACER - 5120-906-1062 WITH HANDLE - 5120-034-0884.

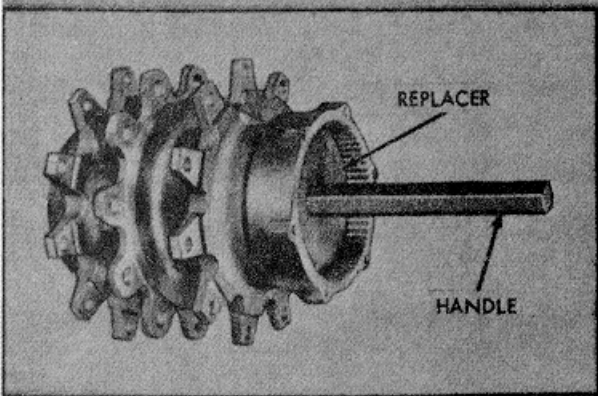

E. INSTALLING SPROCKET HUB OUTER OIL SEAL USING REPLACER - 5120-906-1057 WITH HANDLE - 5120-034-0884.

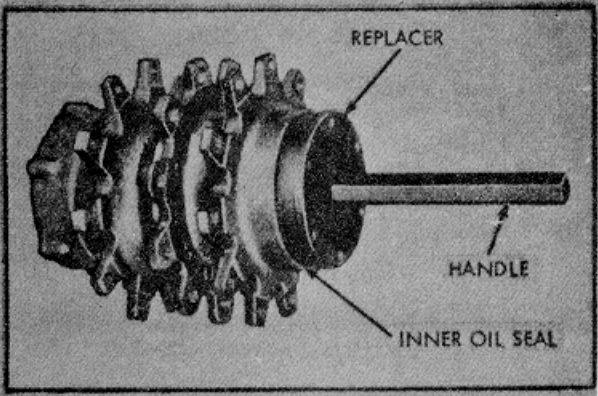

F. INSTALLING SPROCKET HUB INNER OIL SEAL USING REPLACER - 5120-906-1056 WITH HANDLE - 5120-034-0884.

WE 11017

Figure 9-79. Suspension system special tools (4 of 4)

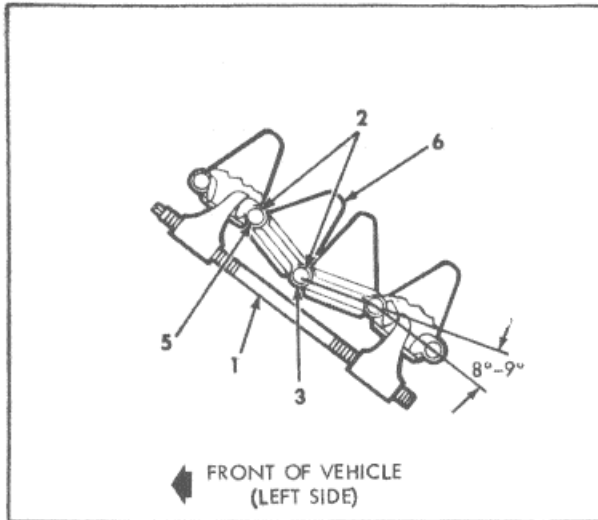

A. USING TRACK FIXTURE-4910-906-1053 ON TRACK ASSEMBLY.

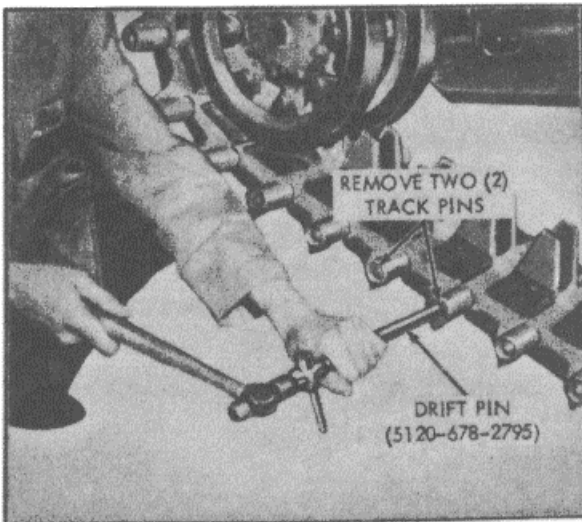

B. USING DRIFT PIN-5120-678-2795.

PROCEDURE FOR REMOVING TRACK SHOE WHEN FULL EXTENSION OF TRACK HYDRAULIC ADJUSTER FAILS TO MAINTAIN PROPER TRACK TENSION.

PRELIMINARY STEPS

- A. OPERATE VEHICLE AND COAST TO STOP.
- B. BLOCK TRACK ON OPPOSITE SIDE OF VEHICLE.
- C. LOOSEN BLEED PLUG ON TRACK HYDRAULIC ADJUSTER TO RELEASE TENSION ON TRACK.

REMOVAL

1. INSTALL TRACK FIXTURE-4910-906-1053 AT IDLER END AND TIGHTEN AS SHOWN IN FIG. A.
2. REMOVE OUTSIDE TRACK PIN NUTS FROM ADJACENT TRACK PINS SECURING ONE SHOE.
3. DRIVE OUT TRACK PIN CENTERED IN TRACK FIXTURE USING DRIFT PIN-5120-678-2795 (FIG. B); THEN WITHDRAW DRIFT PIN FROM SHOES.
4. TAP SHOES WITH HAMMER OR PRY WITH CROWBAR TO SEPARATE SHOES. IF NECESSARY LOOSEN TRACK FIXTURE TO DISENGAGE SHOES.
5. DRIVE OUT SECOND TRACK PIN (USING DRIFT PIN) AND REMOVE SHOE FROM TRACK.
6. TIGHTEN TRACK FIXTURE WHILE GUIDING LOOSE SHOE INTO POSITION WITH FIXED SHOE. USE CROWBAR IF NECESSARY.
7. INSTALL DRIFT PIN-5120-678-2795 THROUGH TRACK SHOE BUSHINGS FROM VEHICLE SIDE OF TRACK.
8. REPOSITION TRACK FIXTURE SO THAT DRIFT PIN IS LOCATED MIDWAY BETWEEN TRACK FIXTURE JAWS. TIGHTEN TRACK FIXTURE UNTIL TRACK SHOES ARE POSITIONED 8 - 9° AS SHOWN IN FIG. A. USE CROWBAR IN SPROCKET HOLE OF SHOE TO ASSIST.
9. INSTALL TRACK SHOE PIN AND NUTS, TIGHTEN NUTS TO 120-130 POUNDS-FEET.
10. RELEASE TRACK FIXTURE. REFER TO FIG. 5-4 FOR TRACK ADJUSTMENT.

**NOTE** AFTER 50 MILES OF OPERATION, RETIGHTEN ALL DISTURBED TRACK PIN NUTS TO 120-130 POUNDS-FEET.

WE 11018

Figure 9-80. Removal-track shoe



**CRITERIA FOR TRACK SHOE REPLACEMENT**

- A. WHEN BOTH TRACK SHOE GUIDES ARE MISSING ON A SINGLE SHOE, OR WHEN THREE OR MORE GUIDES IN A ROW ARE DAMAGED, THE SHOE(S) SHOULD BE REPLACED.
- B. A GUIDE IS CONSIDERED MISSING WHEN 75% OF GUIDE IS GONE, AND IS CONSIDERED DAMAGED IF MORE THAN 1/3 OF GUIDE IS MISSING, OR GUIDE IS BENT AND INTERFERES WITH RELATED COMPONENTS. A GUIDE WORN THROUGH AT POINT "Y" (VIEW A) IS NOT CONSIDERED DAMAGED UNTIL STRUCTURAL STRENGTH IS IMPAIRED TO THE POINT OF BENDING.
- C. SHOES WITH SPROCKET OPENING (DIMENSION X, VIEW A) ELONGATED TO MORE THAN 2-5/16 INCHES ARE TO BE REPLACED.
- D. IF 25 OR MORE GUIDES ARE MISSING, THE ENTIRE TRACK SHOULD BE REPLACED.
- E. IN CASES OF EMERGENCY, THREE OR MORE CONSECUTIVE SHOES WITH MISSING OR DAMAGED GUIDES MAY BE SEPARATED AND RELOCATED PENDING LATER REPLACEMENT.
- F. WHEN RUBBER PADS ARE MISSING FROM GUIDE SIDE OF TRACK SHOE, REPLACE SHOE.
- G. WHEN 10% OF RUBBER PADS ARE MISSING FROM ROAD SIDE OF ONE TRACK ASSEMBLY, REPLACE ALL SHOES INVOLVED. REPLACE SHOES WHEN GROUSER-HEIGHT WEAR IS OVER 7/16 INCH.
- H. WHEN RUBBER PADS ARE MISSING FROM THREE OR MORE CONSECUTIVE SHOES, REPLACE SHOES OR INTERMIX WITH GOOD SHOES.

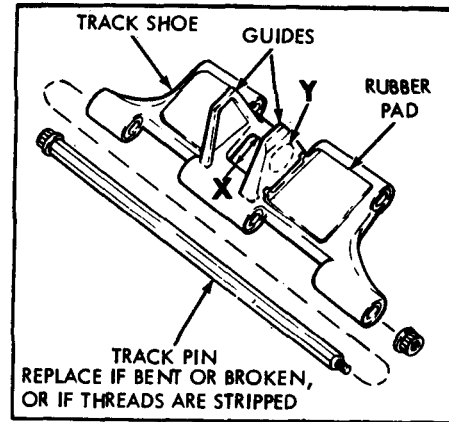

A. TRACK SHOE AND PIN DETAIL.

**REPLACEMENT OF ONE DAMAGED SHOE**

FOLLOW PRELIMINARY STEPS AND STEPS 1 THROUGH 5, FIG. 9-80. INSTALL NEW SHOE BY REVERSING REMOVAL PROCEDURE. TIGHTEN NUTS TO 120-130 POUND-FEET.

**REPLACEMENT OF A DAMAGED SECTION OF TRACK**

1. MOVE VEHICLE SO ONE END OF DAMAGED SECTION STOPS BETWEEN THE IDLER AND NO. 1 ROAD WHEEL AND THE BALANCE RESTS UNDER THE ROAD WHEELS; THEN PERFORM PRELIMINARY STEPS B AND C, FIG. 9-80.
2. INSTALL TRACK FIXTURE (FIG. 9-80, A), REMOVE TRACK PIN OUTER NUT AND DISCONNECT DAMAGED TRACK SECTION FROM GOOD SECTION USING DRIFT PIN - 5120-678-2795.
3. RELEASE AND REMOVE TRACK FIXTURE.
4. BACK UP VEHICLE SLOWLY, GUIDING TRACK OVER IDLER AND ROAD WHEELS UNTIL BALANCE OF DAMAGED SECTION IS FULLY EXPOSED.
5. REMOVE TRACK PIN NUT AND PIN AT END OF DAMAGED SECTION; REMOVE SECTION.
6. INSTALL NEW TRACK SHOES, PINS, AND NUTS USING DRIFT PIN - 5120-678-2795 TO LINE UP SHOES BEFORE INSTALLING TRACK PINS. MAINTAIN 8 - 9° ANGLE ILLUSTRATED ON FIG. 9-80, VIEW A. TIGHTEN TRACK PIN NUTS TO 120 - 130 POUNDS-FEET.
7. REINSTALL TRACK AND ADJUST TRACK TENSION. REFER TO FIG. 5-5.

**NOTE.** AFTER 50 MILES OF OPERATION, RETIGHTEN ALL DISTURBED TRACK PIN NUTS TO 120 - 130 POUND-FEET.

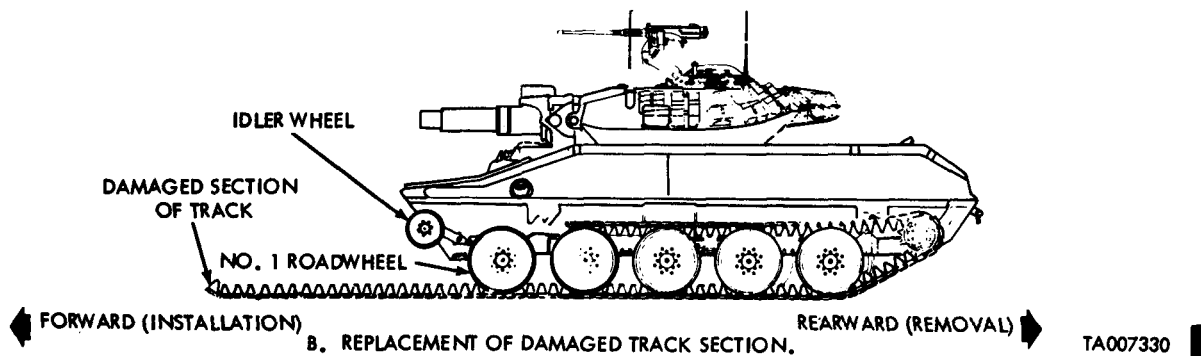

B. REPLACEMENT OF DAMAGED TRACK SECTION.

TA007330

Figure 9-81. Replacing damaged track shoe(s).

**Section 9-5. HULL AND POWER PLANT ELECTRICAL**

**9-13. General**

a. This section covers organizational maintenance functions on hull and power plant electrical components listed in table 9-11. Front and rear hull schematic diagrams are illustrated in figures 9-84 and 9-85. Hull and power plant electrical harness diagrams are illustrated in figures 9-82 and 9-83.

b. Each electrical cable is marked with a circuit-numbered metal tag attached to the junction or terminal end of the cable. All electrical circuits, shown in schematic and wiring diagrams, are identified by circuit numbers listed in table 9-12.

**CAUTION:** Turn master switch off before disconnecting or connecting electrical connectors to avoid possible arcing.

TABLE 9-11. HULL AND POWER PLANT ELECTRICAL

ASSEMBLY OR COMPONENT	FIGURE REFERENCE		
	ADJUST	REPLACE	REPAIR
Headlights	9-86		9-87 thru 9-91 9-92,93
Taillights			
Headlight Dimmer Switch		9-94	
Dome Light		9-95	9-96
Batteries		9-97	
Auxiliary Power (Slave) Receptacle		9-94	
Master Relay		9-98	
Hull Circuit Breaker		9-100	
Driver's Switch Panel		9-101	9-102, thru 9-105
Driver's Switch Panel Rectifier		9-103.1	
Time Delay Assembly		9-103.2	
Turret Master Relay		9-103.3	
Electrical Harnesses		9-103.4, 9-103.5	
Driver's Indicator Panel		9-106	
Personnel Heater Control Box		9-107	9-107
Neutral Safety Switch	9-47	9-100	
Water Steer Switch	9-54	9-100	
Bilge Pump Relays and Mount		9-108	
"V" Belt Tensioner and Belts		9-109	
Generator Voltage Regulator	9-110.1 9-110.1	9-110, 9-110.1	
Generator Drive and Pulley		9-111, 9-112	
Generator-to-Voltage Regulator Wiring Harness		9-112.1	9-112.1
Engine Starter		9-113	
Starter Relay		9-100	
Power Plant Temperature and Pressure Switches and Transmitters		9-114	

TABLE 9-11. HULL AND POWER PLANT ELECTRICAL - CONTINUED

ASSEMBLY OR COMPONENT	FIGURE REFERENCE		
	ADJUST	REPLACE	REPAIR
Tachometer and Speedometer Generators and Drives		9-115	9-116
Fuel Level Transmitters		9-99	
Electrical Cable Terminals and Connectors			9-117
Electrical Harness Plugs			9-118
Electrical Harness Receptacle Connectors			9-118

TABLE 9-12. HULL ELECTRICAL CIRCUIT NUMBER REFERENCE CHART

CIRCUIT NUMBER	CIRCUIT
10	Battery ground
11	Battery-to-master relay
12	Master relay-to-master switch
12B	Battery-to-master switch
12L	Master switch warning light
13	Battery-to-voltage regulator
14	Voltage regulator-to-generator armature
15	Voltage regulator-to-generator field
21	Power circuit-to-starter
22	Neutral safety switch - starter relay
22A	Neutral safety switch - starter switch
22A	Power circuit-to-starter relay
22B	Power circuit-to-starter relay solenoid
30	Upper fuel level transmitter - ground
31A	Circuit breaker-to-windshield wiper switch and engine starter relay switch
31B	Circuit breaker-to-bilge pump switch and flame heater switch
31C	Circuit breaker-to-engine indicator panel
32A	Upper fuel level transmitter-to-engine indicator panel
32B	Upper fuel level transmitter-to-lower fuel level transmitter
32C	Lower fuel level transmitter-to-engine indicator panel (through fuse)
34	Engine coolant transmitter-to-engine indicator panel
39	Engine coolant high temperature thermostatic switch-to-engine indicator panel
40	Headlight ground
41	Power circuit-main light switch
42	Light switch-to-service taillight
43	Light switch-to-B.O. marker taillight
44	Light switch-to-service stoplight
45	Light switch-to-B.O. stoplight
48	Light switch-to-B.O. marker headlight
50	Wiper assembly-to-ground
50A	Water steer switch - engine indicator panel warning light
50B	Parking brake "ON" switch-to-engine indicator panel warning light
50G	Parking brake "ON" switch-to-ground
55	Circuit breaker-to-auxiliary outlet
57	Power lead to driver's periscope (M48)
70	Slave receptacle negative-to-ground

TABLE 9-12. HULL ELECTRICAL CIRCUIT NUMBER REFERENCE CHART - CONTINUED

CIRCUIT NUMBER	CIRCUIT
71	Power circuit-to-slave receptacle positive
75	Flame heater switch-to-flame heater ignition coil and fuel solenoid
111	Master relay-to-power circuit
112	Battery interconnecting cable - positive-to-negative
152	Voltage regulator-to-generator interpole
313	Engine lo-oil pressure switch-to-engine indicator panel
314	Transmission oil high temperature thermostatic switch-to-engine indicator panel
315	Transmission lo-oil pressure switch-to-engine indicator panel
322	TACHOMETER GENERATOR-TO-ENGINE INDICATOR PANEL.
323	Speedometer switch-to-speedometer generator and engine indicator panel
323C	Odometer switch-to-engine indicator panel
422	Light switch-to-LR./B. O. headlight selector switch
422A	LR./B.O. switch-to-B.O. drive headlight
423	Light switch-to-stoplight switch
424	Light switch-to-headlight dimmer switch - service drive
425	Headlight dimmer switch-to-high beam service headlight
426	Headlight dimmer switch-to-low beam service headlight
427	L R. /B. O. high beam headlight switch-to-headlight dimmer switch and L R. /B. O. high beam headlight
427L	I.R. warning light
428	LR./B.O. low beam headlight switch-to-headlight dimmer switch and LR./B.O. low beam headlight
428L	I.R. warning light
429	Headlight dimmer switch-to-engine indicator panel - high beam indicator light
432	Circuit breaker-to-dome lights
432A	Light switch-to-panel light on engine indicator panel - driver's switch panel
521	Windshield wiper switch-to-windshield wiper
521B	Circuit breaker-to-windshield wiper
521L	Windshield wiper warning light
560	Personnel heater-to-ground
561	Battery-to-heater control box (personnel and winterization kit)
562	Heater control-to-coil and flame detector switch
563	Heater control-to-coolant thermostat and solenoid valve
563A	Heater control-to-fuel pump
564	Heater control-to-blower motor
565	Heater control-to-flame detector switch
721	Bilge pump switch-to-bilge pump relay
721B	Rear bilge pump relay
721BL	Rear bilge pump indicator light
721L	Front bilge pump indicator light
722	Power circuit-to-bilge pump relay (rear bilge pumps)
722A	Bilge pump relay-to-circuit breaker (rear bilge pumps)
722B	Circuit breaker - left rear bilge pump
722C	Circuit breaker - right rear bilge pump
723	Power circuit-to-bilge pump relay (front bilge pump)
723A	Bilge pump relay-to-circuit breaker (front bilge pump)
723B	Circuit breaker-to-front bilge pump

TABLE 9-12. HULL ELECTRICAL CIRCUIT NUMBER REFERENCE CHART - CONTINUED

CIRCUIT NUMBER	CIRCUIT
11T	MASTER RELAY-TO-TURRET POWER RELAY.
12C	STARTER SWITCH-TO-RECTIFIER.
12T	TIME DELAY-TO-TURRET POWER RELAY.
22T	TIME DELAY-TO-STARTER SWITCH.
23	B. O. STOPLIGHT LEAD, RIGHT.
24	B. O. MARKER TAILLIGHT, LEFT AND RIGHT.
50	AIR CLEANER BLOWER MOTOR RELAY-TO-RELAY SWITCH..
58	BLOWER MOTOR-TO-RELAY.
58A	BLOWER MOTOR-TO-RELAY.
111T	TURRET POWER RELAY-TO-SLIPRING.
322A	TACHOMETER SWITCH-TO-ENGINE INDICATOR PANEL.
581	STARTER RELAY-TO-BLOWER MOTOR RELAY.
720	FIRE EXTINGUISHER SOLENOID-TO-GROUND.
725	FIRE EXTINGUISHER SOLENOID-TO-SLIPRING.
726	TURRET POWER RELAY-TO-SLIPRING.

(9-92. 2 blank)/9-92.1

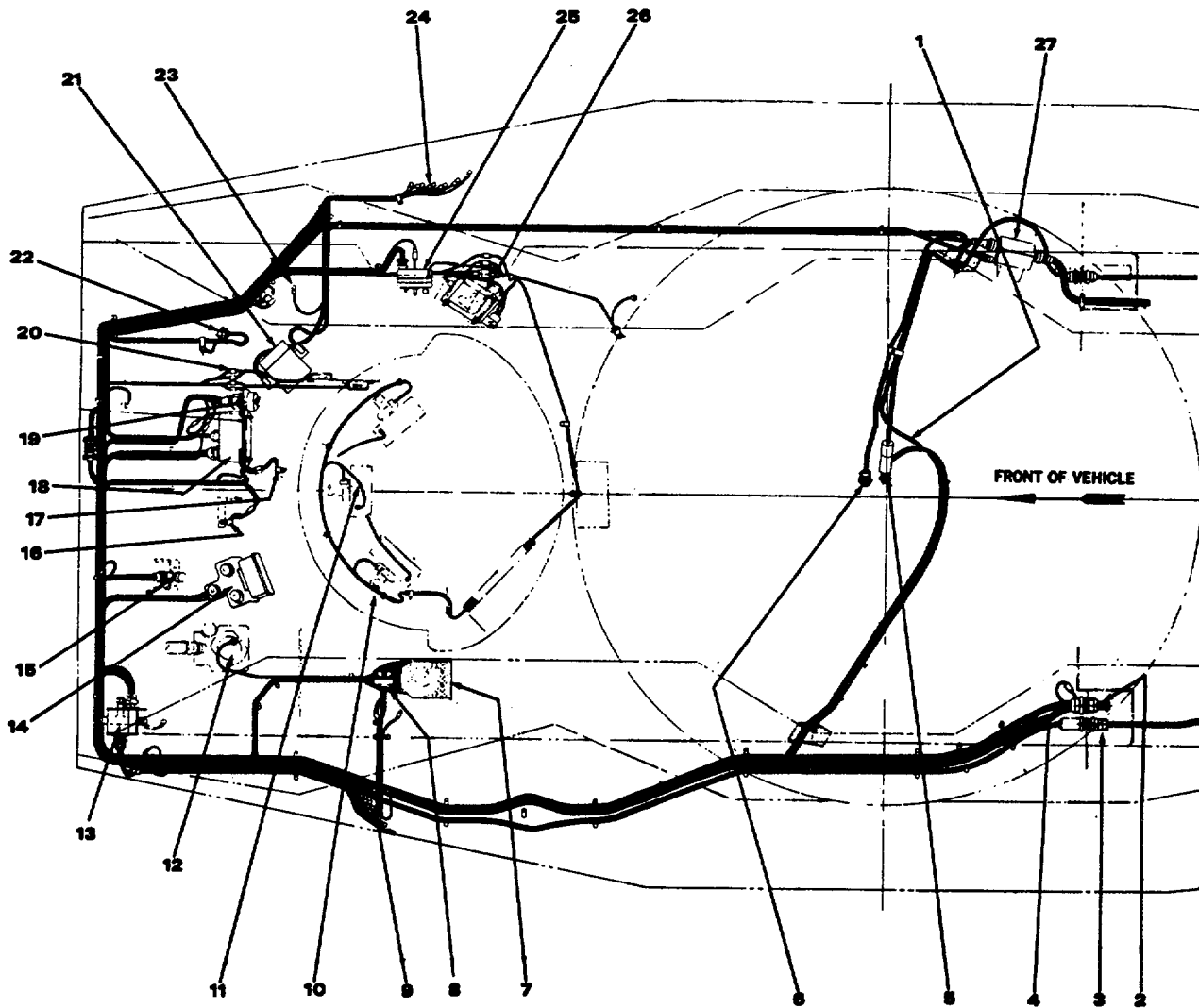

**LEGEND**

- |   |   |
|---|---|
| <ul style="list-style-type: none"> <li>1. HULL FRONT POWER</li> <li>2. TO ENGINE ELECTRICAL</li> <li>3. TO REAR INTERCOMMUNICATION SET</li> <li>4. (LOWER) TO HULL REAR ELECTRICAL</li> <li>5. COMMUNICATION HARNESS - TURRET SLIP RING</li> <li>6. HULL POWER TO TURRET SLIP RING</li> <li>7. CIRCUIT BREAKERS</li> <li>8. SLAVE RECERTACLE</li> <li>9. LEFT HEADLIGHT LEADS</li> <li>10. DRIVER'S PERISCOPE WIPERS (3)</li> <li>11. DRIVER'S M48 PERISCOPE LEAD</li> <li>12. BILGE PUMP - FRONT</li> <li>13. BILGE PUMP RELAYS (2)</li> <li>14. DRIVER'S INDICATOR PANEL</li> </ul> | <ul style="list-style-type: none"> <li>15. HEADLIGHT DIMMER SWITCH</li> <li>16. STOPLIGHT SWITCH</li> <li>17. PARKING BRAKE SWITCH</li> <li>18. DRIVER'S SWITCH PANEL</li> <li>19. LIGHT SWITCH</li> <li>20. NEUTRAL SAFETY SWITCH AND WATER STEER SWITCH LEADS</li> <li>21. DRIVER'S INTERCOM BOX</li> <li>22. TO PERSONNEL HEATER</li> <li>23. TO PERSONNEL HEATER FUEL PUMP</li> <li>24. RIGHT HEADLIGHT LEADS</li> <li>25. PERSONNEL HEATER LEADS CONTROL BOX</li> <li>26. DOME LIGHT</li> <li>27. TURRET POWER DISCONNECT RELAY</li> </ul> |
|---|---|

TA-007300

Figure 9-82. Hull electrical wiring diagram.

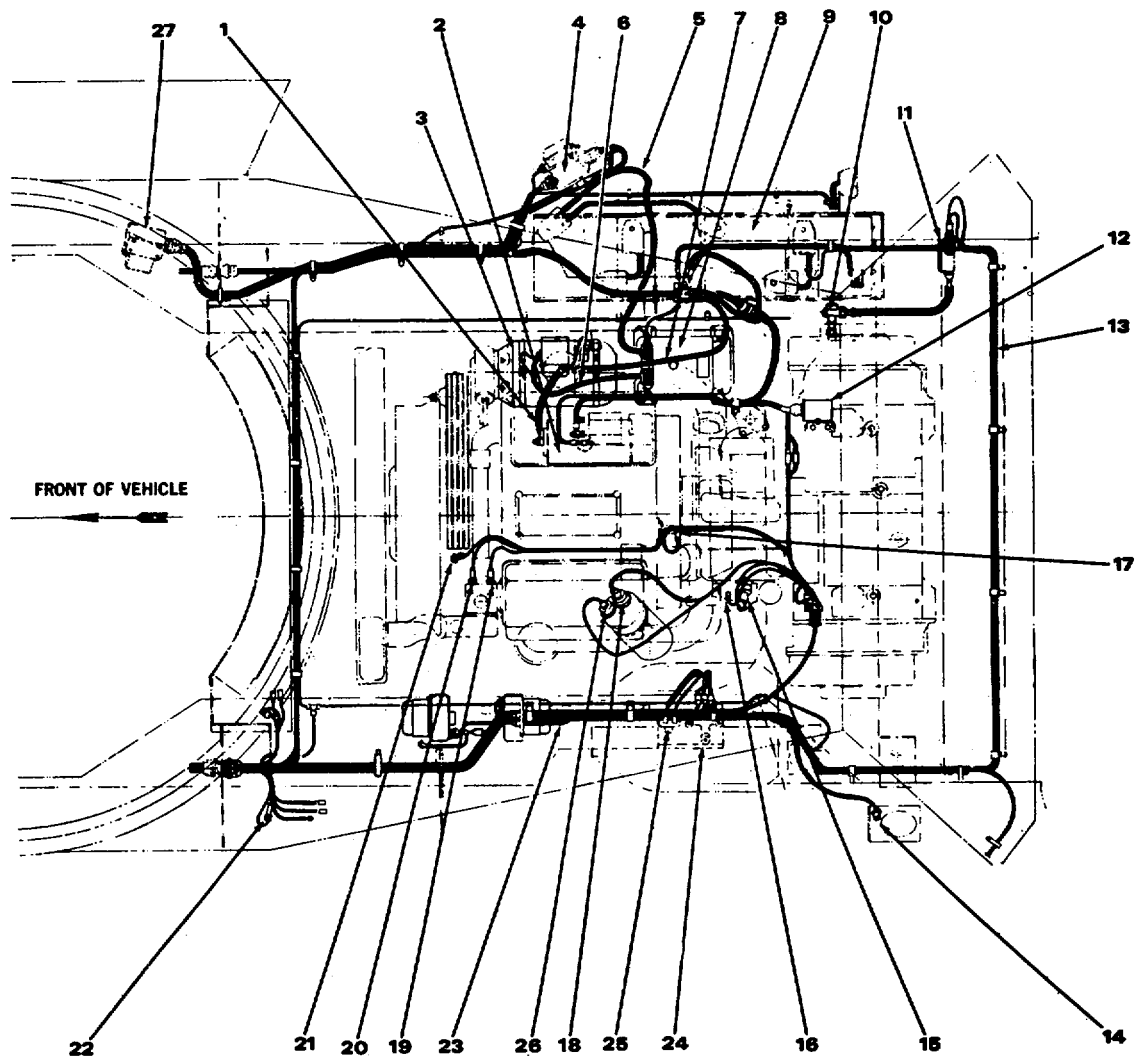

**LEGEND**

- |   |  |
|---|--|
| 1. GENERATOR-TO-STARTER GROUND LEAD       | 15. TRANSMISSION OIL LOW PRESSURE SWITCH                   |
| 2. ENGINE STARTER MOTOR                   | 16. TRANSMISSION OIL HIGH TEMPERATURE SWITCH               |
| 3. GENERATOR                              | 17. TACHOMETER GENERATOR                                   |
| 4. MASTER RELAY                           | 18. ENGINE LOW OIL PRESSURE SWITCH                         |
| 5. BATTERY-TO-VOLTAGE REGULATOR LEAD      | 19. ENGINE COOLANT HIGH TEMPERATURE SWITCH                 |
| 6. GENERATOR-TO-VOLTAGE REGULATOR HARNESS | 20. ENGINE COOLANT TRANSMITTER                             |
| 7. GENERATOR/ENGINE GROUND LEAD           | 21. AIR BOX (FLAME) HEATER IGNITER COIL AND SOLENOID VALVE |
| 8. VOLTAGE REGULATOR                      | 22. FUEL LEVEL TRANSMITTER FUSE                            |
| 9. BATTERY (4 SHOWN)                      | 23. BLOWER MOTORS LEAD                                     |
| 10. SPEEDOMETER GENERATOR                 | 24. BLOWER MOTOR RELAY                                     |
| 11. ODOMETER ADAPTER                      | 25. BLOWER MOTOR CIRCUIT BREAKER                           |
| 12. STARTER RELAY                         | 26. BLOWER MOTOR RELAY SWITCH                              |
| 13. HULL REAR HARNESS                     | 27. TURRET POWER DISCONNECT RELAY                          |
| 14. GROUND INTERCOM BOX CABLE ASSEMBLY    |  |

TA-007307

Figure 9-83. Power plant electrical wiring diagram.

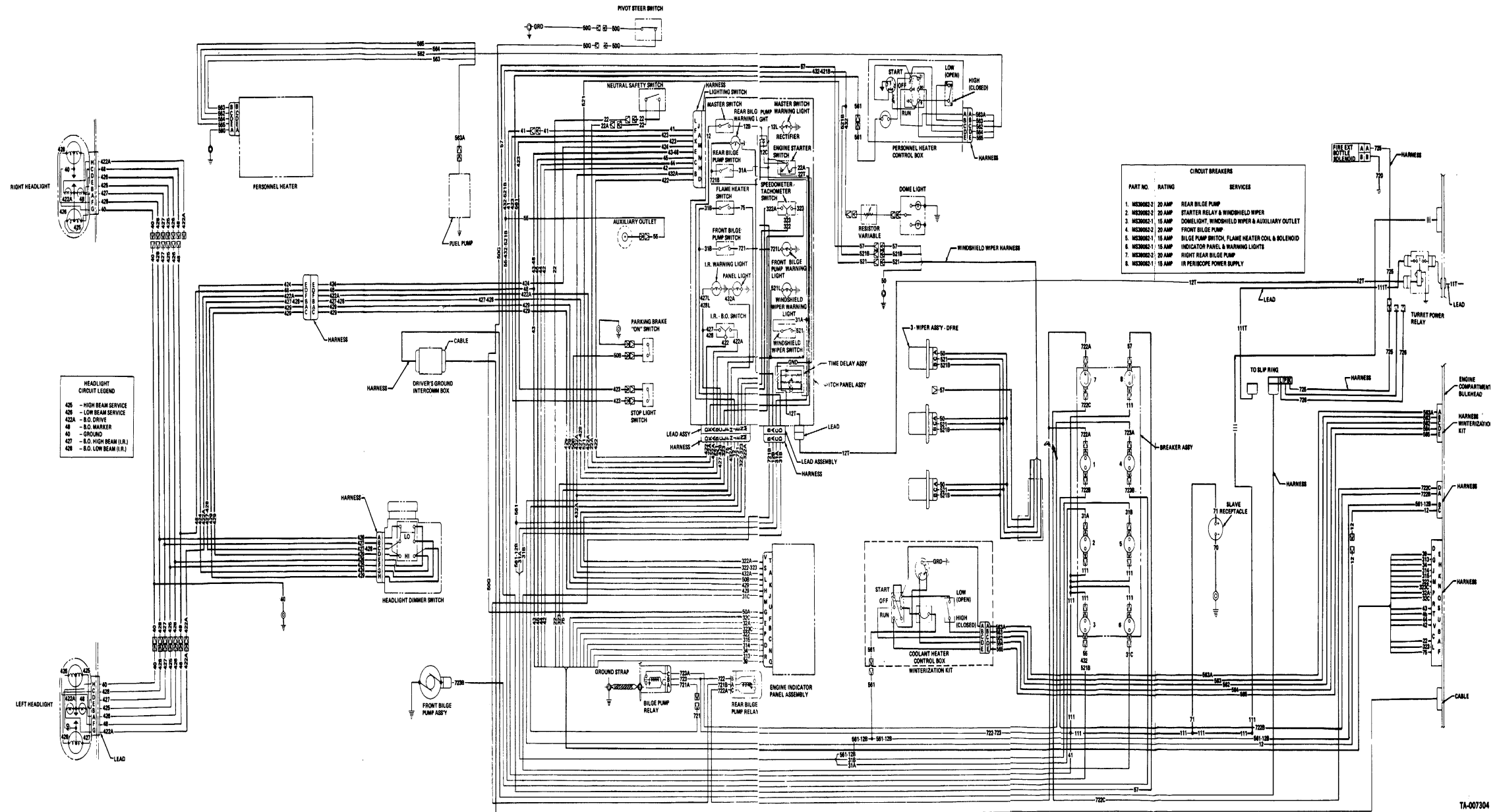
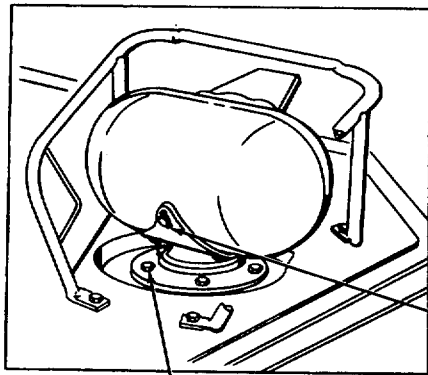
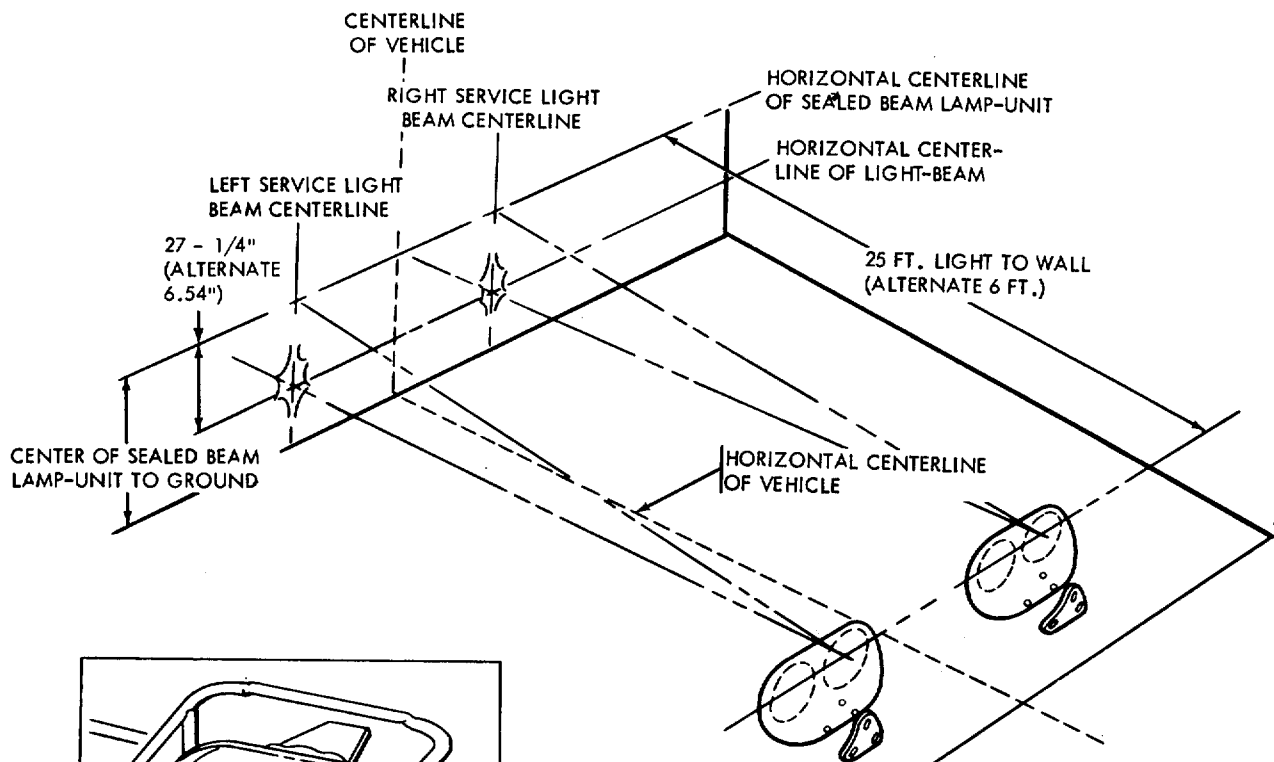

Figure 9-84. Hull electrical schematic (1 of 2)







ADJUSTING SCREWS (5)  
(HORIZONTAL ADJUSTMENT)

ADJUSTING SCREWS (3)  
(VERTICAL ADJUSTMENT)

**HEADLIGHT ADJUSTMENT**

1. TO ADJUST HEADLIGHT BEAM VERTICALLY (UP OR DOWN), LOOSEN 3 SCREWS (SEE INSET). RAISE OR LOWER HEADLIGHT AS REQUIRED. TIGHTEN SCREWS.
2. TO ADJUST HEADLIGHT HORIZONTALLY LOOSEN 5 SCREWS IN MOUNT (SEE INSET) AND ROTATE HEADLIGHT IN SOCKET AS REQUIRED. TIGHTEN SCREWS.

**BEAM ALIGNMENT PROCEDURE**

1. PARK VEHICLE ON LEVEL PAVEMENT OR APRON. ALIGN VEHICLE TORSION BAR AXIS PARALLEL TO A WALL OR LARGE SCREEN. THE DISTANCE BETWEEN HEADLIGHT AND WALL OR SCREEN SHALL MEASURE 25 FEET.
2. DRAW A LINE PERPENDICULAR TO WALL OR SCREEN PASSING THROUGH CENTER OF VEHICLE.
3. MEASURE DISTANCE FROM CENTER OF SEALED UNIT (SERVICE SIDE, CLEAR) TO GROUND; DUPLICATE THIS MEASUREMENT ON WALL OR SCREEN, DRAWING A HORIZONTAL CENTERLINE OF LAMP. NEXT DRAW A PARALLEL LINE 27-1/4 INCHES BELOW THE HORIZONTAL CENTERLINE OF LAMP; THIS LINE WILL BE USED FOR VERTICAL AIMING OF LAMP. AIM CENTER OF HIGHEST LIGHT INTENSITY OF LOW BEAM FOR SERVICE PORTION OF HEADLIGHT ASSEMBLY ON THIS LINE.
4. DRAW A VERTICAL REFERENCE CENTERLINE ON WALL OR SCREEN PERPENDICULAR TO VEHICLE HORIZONTAL CENTERLINE.

5. MEASURE DISTANCE FROM CENTER OF SEALED UNIT (SERVICE SIDE, CLEAR) TO VEHICLE CENTERLINE; DUPLICATE THIS MEASUREMENT ON WALL OR SCREEN, DRAWING VERTICAL CENTERLINE OF LAMP. FOLLOW THIS SAME PROCEDURE FOR BOTH RIGHT AND LEFT HEADLIGHT ASSEMBLIES. THESE VERTICAL CENTERLINES WILL BE USED FOR HORIZONTAL AIMING (LATERAL). AIM CENTER OF HIGHEST LIGHT INTENSITY OF LOW BEAM FROM SERVICE PORTION OF HEADLIGHT ASSEMBLY OF THIS LINE.

**ALTERNATE PROCEDURE**

FOLLOW STEPS 1 THROUGH 5 SUBSTITUTING ALTERNATE DIMENSIONS.

WE 12040

Figure 9-86. Headlight adjustment and beam alignment procedure

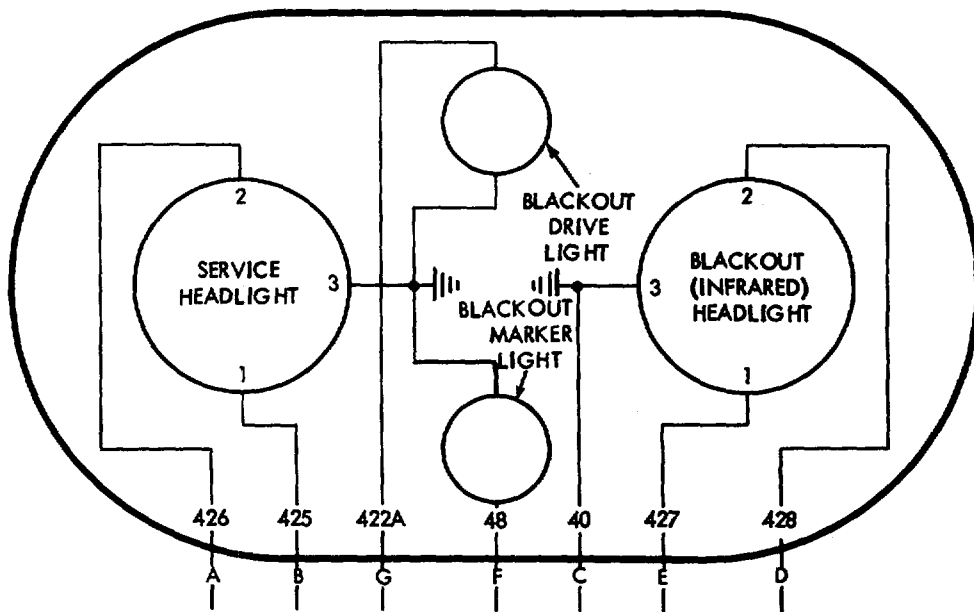

WE 11054

Figure 9-87. Headlight wiring diagram

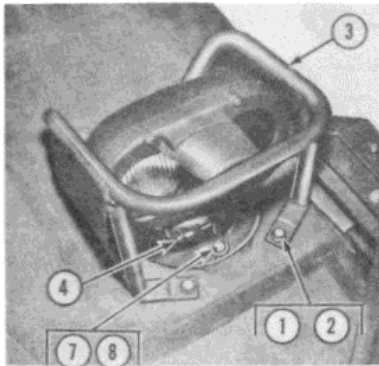

**LEGEND**

- |                       |                      |
|-----------------------|----------------------|
| 1. SCREW (4)          | 6. PREFORMED PACKING |
| 2. FLAT WASHER (4)    | 7. SCREW (5)         |
| 3. GUARD              | 8. FLAT WASHER (5)   |
| 4. CLAMP              | 9. MOUNT GROUP       |
| 5. HEADLIGHT ASSEMBLY | 10. GASKET           |

**REMOVAL**

DISCONNECT ELECTRICAL LEADS (IN DRIVER'S COMPARTMENT) AND REMOVE SHELLS AND "C" WASHERS FROM LEADS.

REMOVE HEADLIGHT ASSEMBLY AND MOUNT GROUP BY FOLLOWING NUMERICAL SEQUENCE.

**NOTE.** COVER GROUP (FIG. 9-90) AND LAMPS (FIG. 9-91) MAY BE REMOVED WITHOUT REMOVING HEADLIGHT FROM VEHICLE.

**INSTALLATION**

REVERSE REMOVAL PROCEDURE.

**NOTE.** REFER TO FIG. 9-86 FOR ADJUSTMENT BEAM ALIGNMENT.

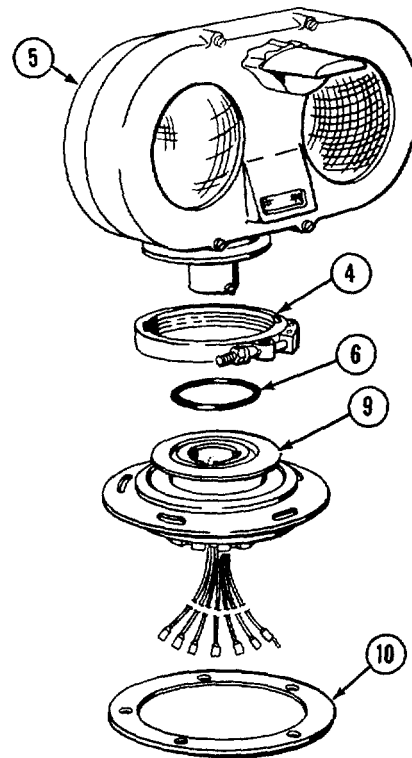
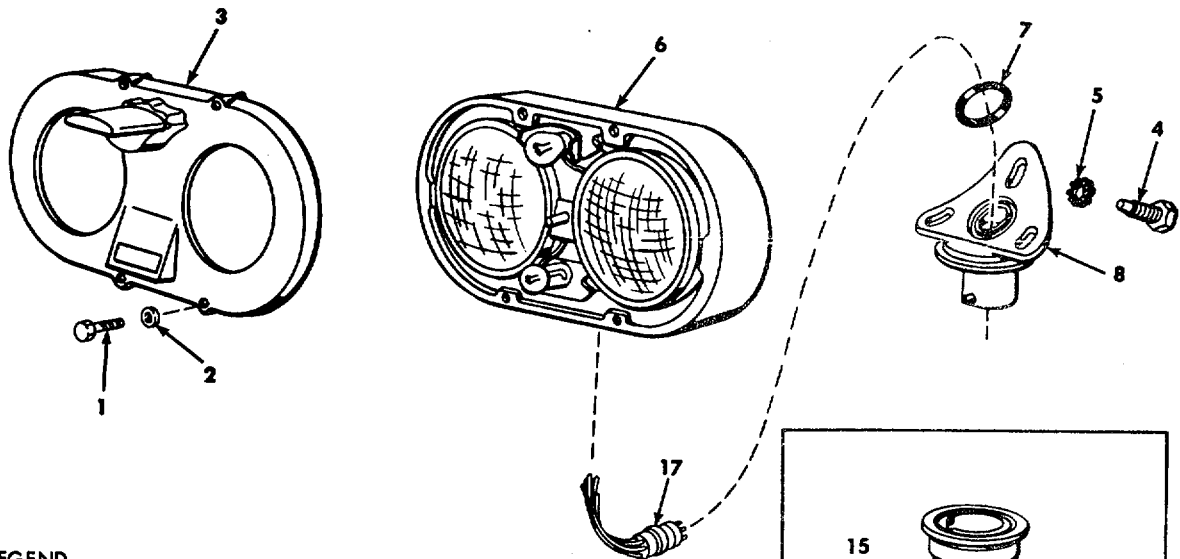

Figure 9-88. Disassembly/assembly - headlight assembly and components (1 of 4)

**LEGEND**

- |                      |                   |
|----------------------|-------------------|
| 1. SCREW (4)         | 10. WASHER        |
| 2. LOCKWASHER (4)    | 11. FLAT WASHER   |
| 3. COVER GROUP       | 12. BASE          |
| 4. SCREW (3)         | 13. FLAT WASHER   |
| 5. WASHER (3)        | 14. MOUNT         |
| 6. HOUSING GROUP     | 15. SPRING PIN    |
| 7. PREFORMED PACKING | 16. LEAD ASSEMBLY |
| 8. SUPPORT           | 17. HARNESS       |
| 9. NUT               |                   |

**DISASSEMBLY**

FOLLOW NUMERICAL SEQUENCE.  
 ITEM 9: PRY UP TAB ON WASHER (10) TO UNLOCK NUT.  
 ITEM 15: REMOVE ONLY WHEN REPLACING LEAD ASSEMBLY (16).  
 ITEM 16: REMOVE BY PRESSING DOWN THROUGH BASE.  
 REMOVE ONLY FOR REPLACEMENT.  
 ITEM 17: REMOVE BY PRESSING DOWN THROUGH SUPPORT.  
 REMOVE ONLY FOR REPLACEMENT.

**ASSEMBLY**

REVERSE DISASSEMBLY PROCEDURE.  
 ITEM 17: THREAD HARNESS LEADS UP THROUGH SUPPORT. ALIGN KEYWAY IN CONNECTOR WITH LOCATOR IN SUPPORT AND PRESS CONNECTOR INTO PLACE. USE MATING ELECTRICAL CONNECTOR TO PROTECT PINS.  
 ITEM 16: THREAD LEADS DOWN THROUGH BASE. ALIGN KEYWAY IN CONNECTOR WITH PIN HOLE IN BASE, AND PRESS INTO PLACE. THEN INSTALL SPRING PIN (15).  
 ITEM 9: AFTER TIGHTENING NUT (9) BEND ONE TAB OF WASHER DOWN TO LOCK NUT.  
 ITEM 3: APPLY A LIBERAL COATING OF SILICONE COMPOUND PASTE, MIL-S-8660, TO GASKET AND MATING SURFACES OF COVER AND HOUSING BEFORE INSTALLATION.

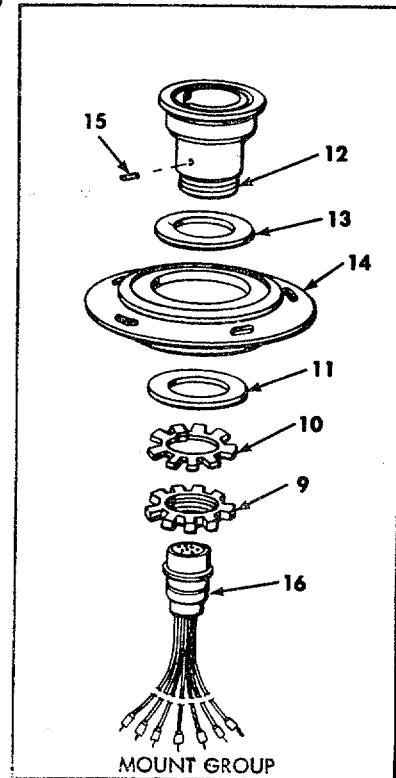

WE 66586

Figure 9-89. Disassembly/assembly - headlight assembly and components (2 of 4)

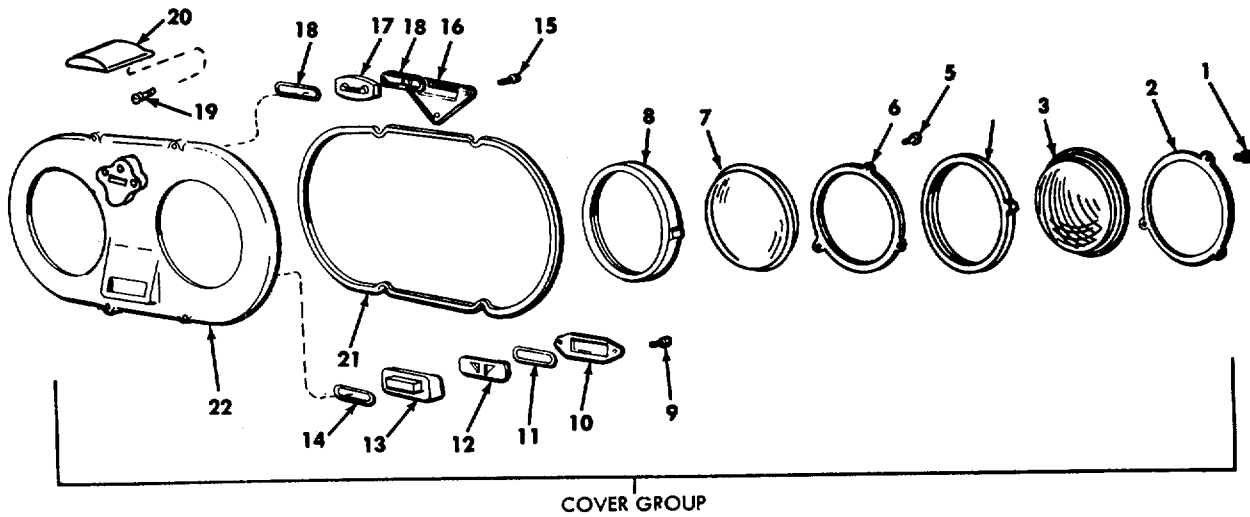
**LEGEND**

- |                          |                          |                           |
|--------------------------|--------------------------|---------------------------|
| 1. SCREW W/LOCKWASHER(3) | 9. SCREW W/LOCKWASHER(2) | 17. BLACKOUT DRIVING LENS |
| 2. RETAINER              | 10. RETAINER             | 18. GASKET (2)            |
| 3. FILTER LENS           | 11. GASKET               | 19. SCREW W/LOCKWASHER(3) |
| 4. GASKET                | 12. FILTER               | 20. SHIELD                |
| 5. SCREW W/LOCKWASHER(3) | 13. BLACKOUT MARKER LENS | 21. GASKET                |
| 6. RETAINER              | 14. GASKET               | 22. COVER                 |
| 7. SERVICE LENS (CLEAR)  | 15. SCREW W/LOCKWASHER   |                           |
| 8. GASKET                | 16. RETAINER             |                           |

**DISASSEMBLY**

FOLLOW NUMERICAL SEQUENCE.

**NOTE. COVER GASKET (21) MAY BE REPLACED WITHOUT DISASSEMBLING COVER GROUP.**

**ASSEMBLY**

REVERSE DISASSEMBLY PROCEDURE.

ITEM 22: REFER TO PARAGRAPH 8-6 AND APPLY ADHESIVE MIL-A-5092 TYPE II TO GASKET AND COVER.

ITEMS 14 AND 18: APPLY SEALING COMPOUND MIL-S-11030 TYPE III BETWEEN GASKETS AND COVER (22).

WE 66587

Figure 9-90. Disassembly/assembly - headlight assembly and components (3 of 4)

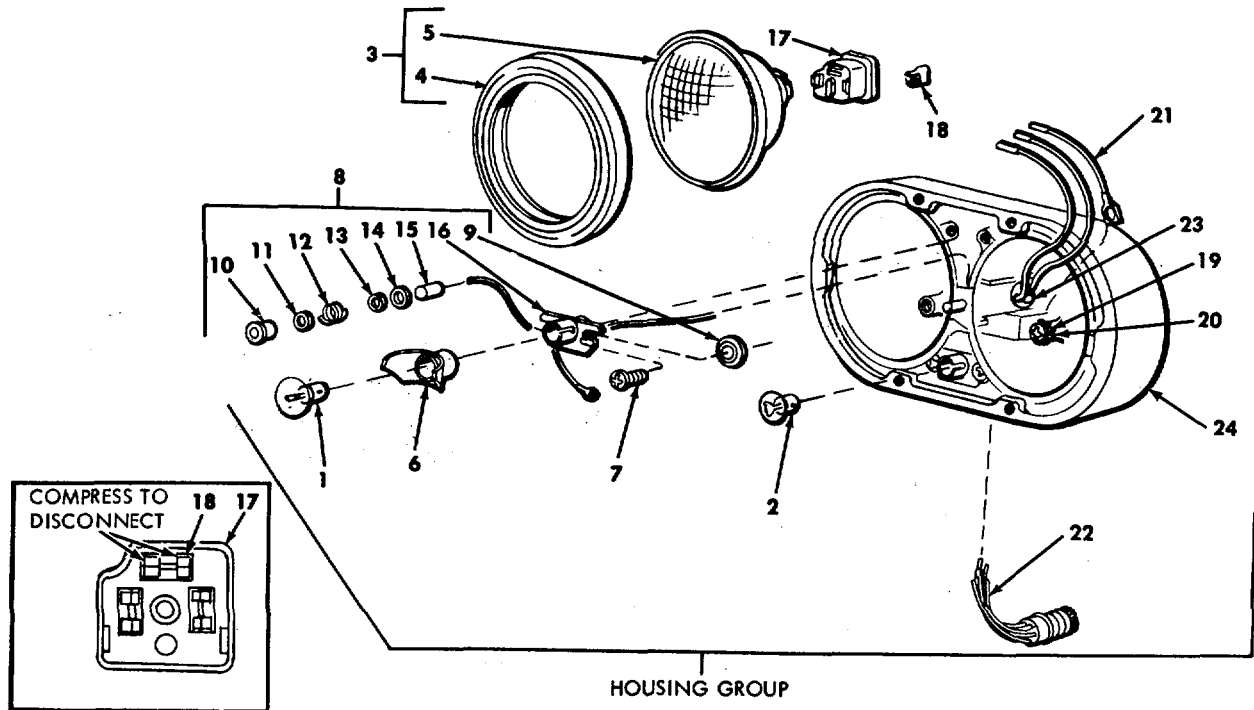

#### LEGEND FOR HOUSING GROUP

- |                                |                      |                            |
|--------------------------------|----------------------|----------------------------|
| 1. 32CP BLACKOUT DRIVE LAMP    | 11. FIBER WASHER (2) |                            |
| 2. 3CP BLACKOUT MARKER LAMP    | 12. SPRING (2)       |                            |
| 3. HEADLIGHT GROUP (2)         | 13. FIBER WASHER (2) |                            |
| 4. GASKET (2)                  | 14. FLAT WASHER (2)  |                            |
| 5. LAMP (2)                    | 15. INSULATOR (2)    |                            |
| 6. REFLECTOR                   | 16. SOCKET ASSY (2)  |                            |
| 7. SCREW (4)                   | 17. CONNECTOR (2)    |                            |
| 8. SOCKET GROUP (2)            | 18. CONTACT (6)      | 21. GROUND LEAD (2)        |
| 9. EYELET AND GROMMET ASSY (4) | 19. SCREW (2)        | 22. HOUSING WIRING HARNESS |
| 10. RIVET (2)                  | 20. LOCK WASHER (4)  | 23. GROMMET                |
|                                |                      | 24. HOUSING                |

#### DISASSEMBLY

DISASSEMBLE BY FOLLOWING NUMERICAL SEQUENCE.

#### DISASSEMBLY NOTES

1. TO DISASSEMBLE SOCKET GROUP (8), PUSH LEADS FORWARD THROUGH SOCKET ASSEMBLY (16), SLIDE INSULATOR (15) OFF LEAD, AND UNSOLDER LEAD FROM CONTACT (10).
2. TO DISASSEMBLE CONTACTS FROM CONNECTOR, USE NEEDLE-NOSE PLIERS TO COMPRESS LOCKING TABS OF CONTACT, THEN PULL CONTACT OUT OF CONNECTOR (SEE INSET).

**NOTE.** CONTACT TABS MUST BE RESTORED TO ORIGINAL SHAPE BEFORE BEING REUSED.

3. LAMPS (ITEMS 1, 2, AND 5) MAY BE REPLACED WITHOUT REMOVING HEADLIGHT FROM VEHICLE.

#### ASSEMBLY

REVERSE DISASSEMBLY PROCEDURE.

WE 66588

Figure 9-91. Disassembly/assembly - headlight assembly and components (4 of 4)

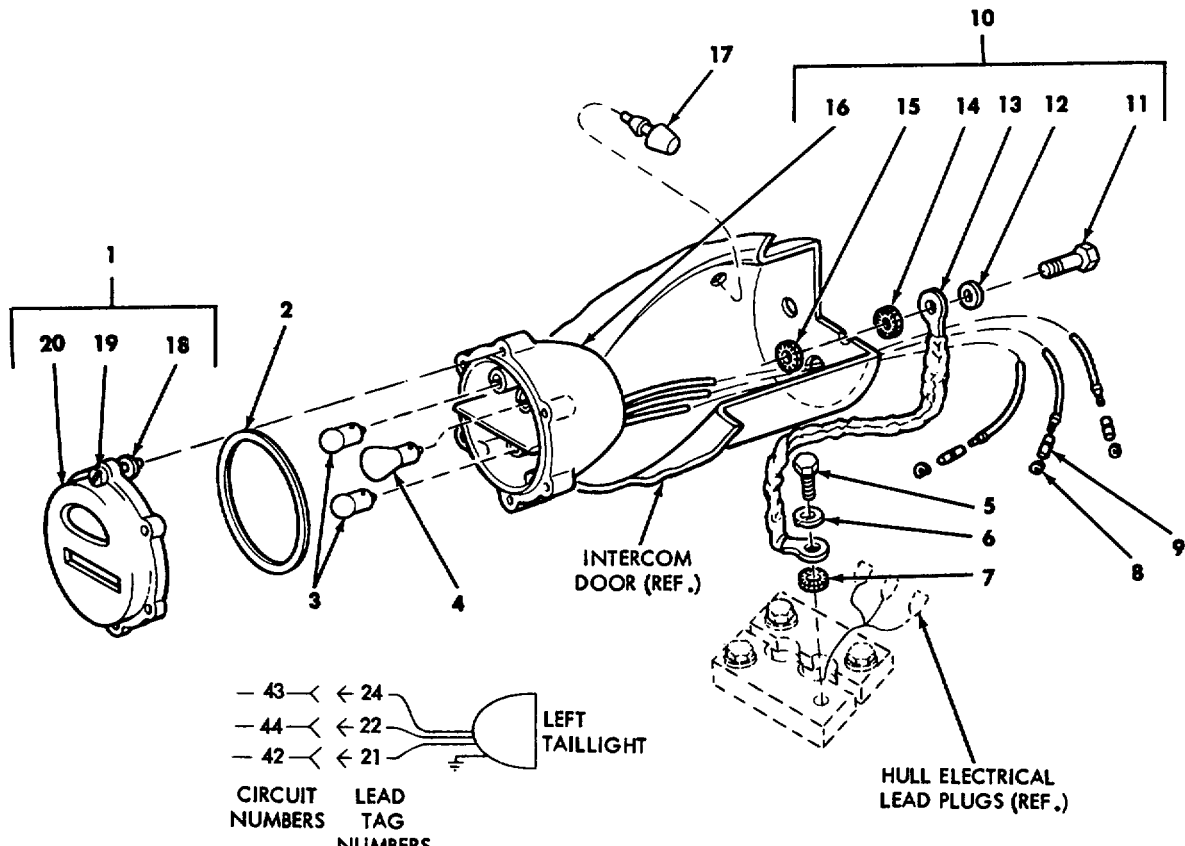

3 CP SERVICE TAIL TAG #21 CIRCUIT #42  
 32 CP SERVICE STOP TAG #22 CIRCUIT #44  
 3 CP BLACKOUT TAIL TAG #24 CIRCUIT #43

WIRING DIAGRAM

**LEGEND FOR LEFT TAILLIGHT**

- |                  |                     |                        |
|------------------|---------------------|------------------------|
| 1. DOOR ASSEMBLY | 8. "C" WASHER (3)   | 15. LOCK WASHER        |
| 2. GASKET        | 9. SHELL (3)        | 16. BODY ASSEMBLY      |
| 3. 3 CP LAMP (2) | 10. BODY GROUP      | 17. PAD (3)            |
| 4. 32 CP LAMP    | 11. SCREW (2)       | 18. RETAINING RING (6) |
| 5. SCREW         | 12. FLAT WASHER (2) | 19. SCREW (6)          |
| 6. FLAT WASHER   | 13. GROUND LEAD     | 20. DOOR               |
| 7. LOCK WASHER   | 14. LOCK WASHER     |                        |

**PRELIMINARY STEP**

TURN MASTER SWITCH TO "OFF" POSITION BEFORE ATTEMPTING TO REMOVE TAILLIGHT.

**REMOVAL/DISASSEMBLY (LEFT TAILLIGHT)**

LIFT UP ON INTERCOM DOOR, DISCONNECT ELECTRICAL LEADS FROM HULL WIRING HARNESS AND REMOVE BY FOLLOWING NUMERICAL SEQUENCE.

**ASSEMBLY/INSTALLATION**

REVERSE REMOVAL/DISASSEMBLY PROCEDURE.

WE 11045

Figure 9-92. Disassembly/assembly - taillights (1 of 2)

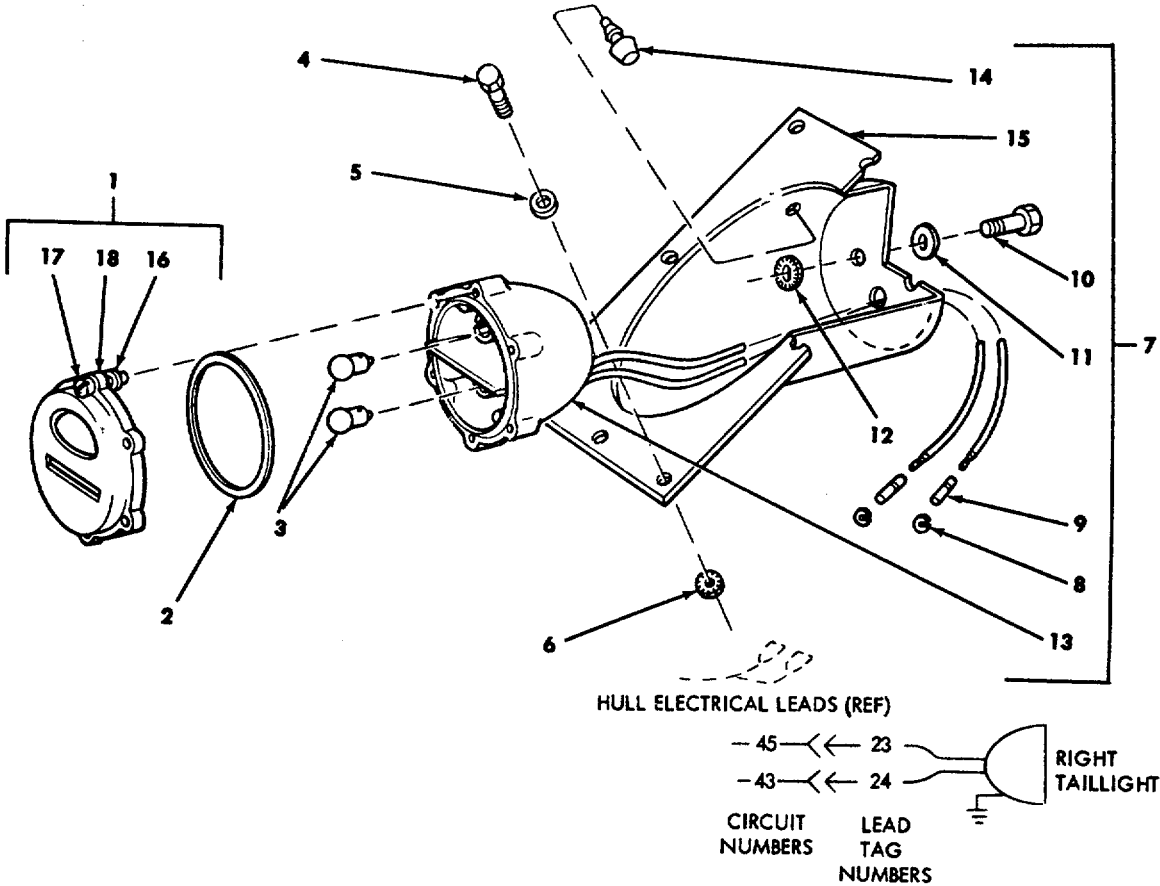

**LEGEND FOR RIGHT TAILLIGHT**

- |                                  |                        |
|----------------------------------|------------------------|
| 1. DOOR ASSEMBLY                 | 10. SCREW (2)          |
| 2. GASKET                        | 11. FLAT WASHER (2)    |
| 3. 3 CP LAMP (2)                 | 12. LOCK WASHER        |
| 4. SCREW (8)                     | 13. BODY ASSEMBLY      |
| 5. FLAT WASHER (8)               | 14. PAD (3)            |
| 6. LOCK WASHER (ONE CORNER ONLY) | 15. HOUSING            |
| 7. BODY - HOUSING GROUP          | 16. RETAINING RING (6) |
| 8. "C" WASHER (2)                | 17. SCREW (6)          |
| 9. SHELL (2)                     | 18. DOOR               |

3 CP BLACKOUT TAIL TAG #24 CIRCUIT #43  
 3 CP BLACKOUT STOP TAG #23 CIRCUIT #45

**WIRING DIAGRAM**

**PRELIMINARY STEP**

TURN MASTER SWITCH TO "OFF" POSITION BEFORE ATTEMPTING TO REMOVE TAILLIGHT.

**REMOVAL/DISASSEMBLY (RIGHT TAILLIGHT)**

REMOVE BY FOLLOWING NUMERICAL SEQUENCE.

**NOTE.** TO REACH ITEM 10, OPEN BATTERY COMPARTMENT DOOR.

**ASSEMBLY/INSTALLATION**

REVERSE REMOVAL/DISASSEMBLY PROCEDURE.

WE 11046

Figure 9-93. Disassembly/assembly - taillights (2 of 2)



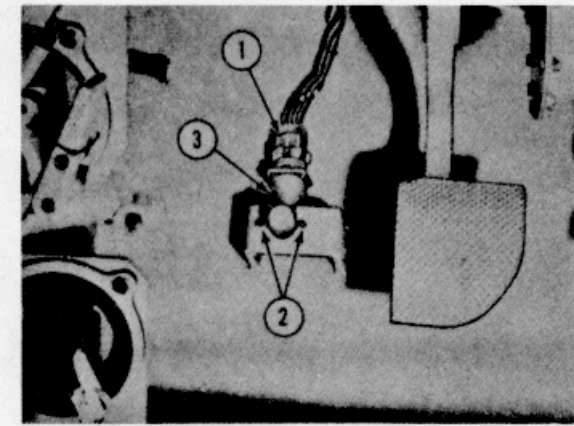

A. HEADLIGHT DIMMER SWITCH INSTALLED VIEW.

REMOVAL

FOLLOW NUMERICAL SEQUENCE.

1. HEADLIGHT HARNESS PLUG NUT.
2. DIMMER SWITCH ATTACHING SCREWS AND FLAT WASHERS.
3. HEADLIGHT DIMMER SWITCH.

INSTALLATION

REVERSE NUMERICAL SEQUENCE.

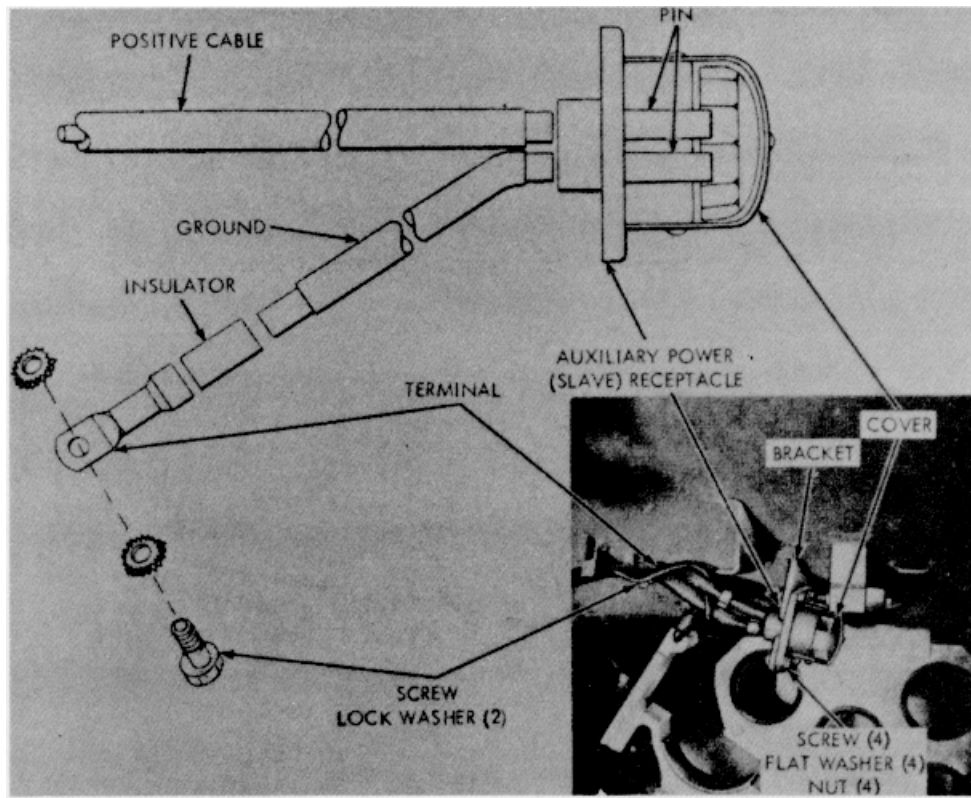

B. AUXILIARY POWER (SLAVE) RECEPTACLE INSTALLED VIEW.

REMOVAL

REMOVE SCREWS, FLAT WASHERS, AND NUTS; SLIDE RECEPTACLE TO LEFT TO REMOVE FROM BRACKET. IF PINS REQUIRE REPLACEMENT, UNSOLDER CABLE FROM PIN.

INSTALLATION

REVERSE REMOVAL PROCEDURE.

WE 11085

Figure 9-94. Removal/installation headlight dimmer switch and auxiliary power (slave) receptacle

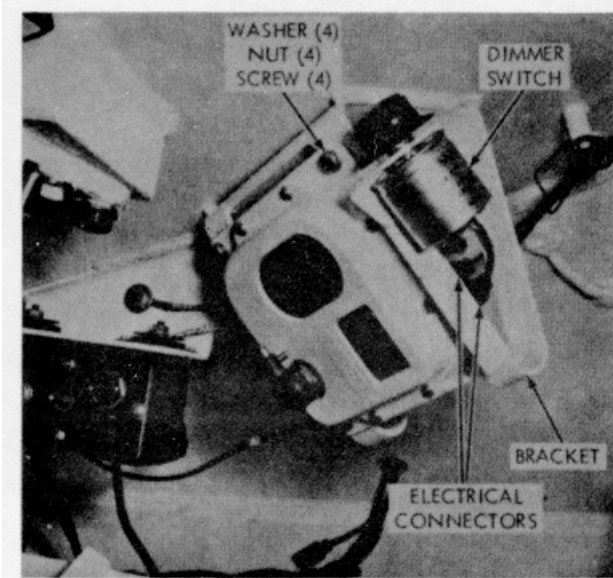

DRIVER'S DOME LIGHT

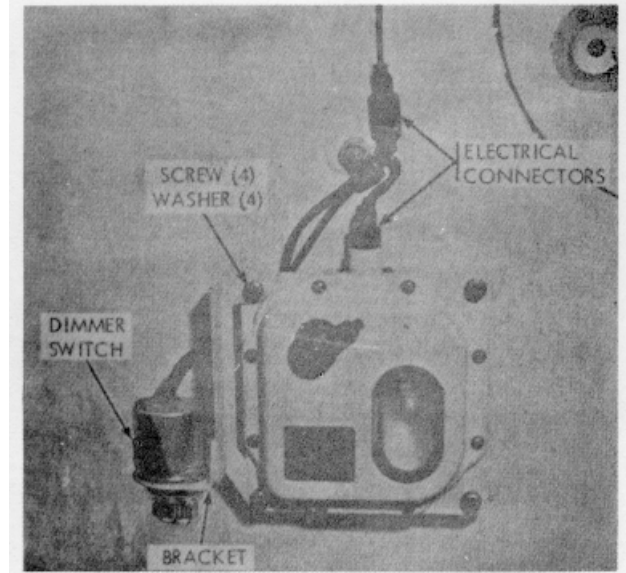

TYPICAL TURRET DOME LIGHT

**REMOVAL**

1. DISCONNECT ELECTRICAL CONNECTORS.
2. REMOVE TWO NUTS AND / OR SCREWS AND WASHERS TO REMOVE DIMMER SWITCH W/BRACKET.
3. REMOVE OTHERS TWO NUTS AND/OR SCREWS AND WASHERS TO REMOVE DOME LIGHT ASSEMBLY

**INSTALLATION**

REVERSE REMOVAL PROCEDURE. REMOVE ALL PAINT AT ONE CORNER TO PROVIDE GOOD GROUND. (SEE FIG. 9-95.1 FOR INSULATION REQUIRED ON DIMMER SWITCH AT LOADER'S STATION.)

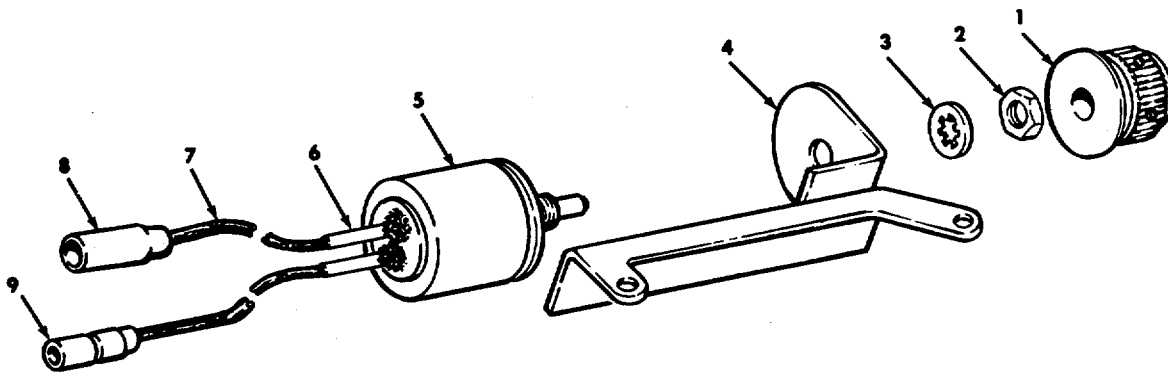

**LEGEND**

1. KNOB
2. NUT
3. WASHER
4. BRACKET
5. RESISTOR
6. INSULATOR (2)
7. LEAD (2)  
(14 GA. WIRE)
8. CONNECTOR  
(B, FIG. 9-117)
9. CONNECTOR  
(D, FIG. 9-117)

**DISASSEMBLY/ASSEMBLY**

LOOSEN TWO SETSCREWS TO REMOVE KNOB. REMOVE NUT AND WASHER TO REMOVE RESISTOR FROM BRACKET. REPLACE UNSERVICEABLE PARTS AS REQUIRED.

**NOTE.** AT LOADER'S STATION ONLY, EXPOSED TERMINAL LUGS OF RESISTOR MUST BE COVERED WITH APPROXIMATELY 1/4 INCH COATING OF ADHESIVE COMPOUND 8040-867-4358 (MIL-L-46106).

WE 12026

Figure 9-95.1. Disassembly/assembly - dome light dimmer switch.

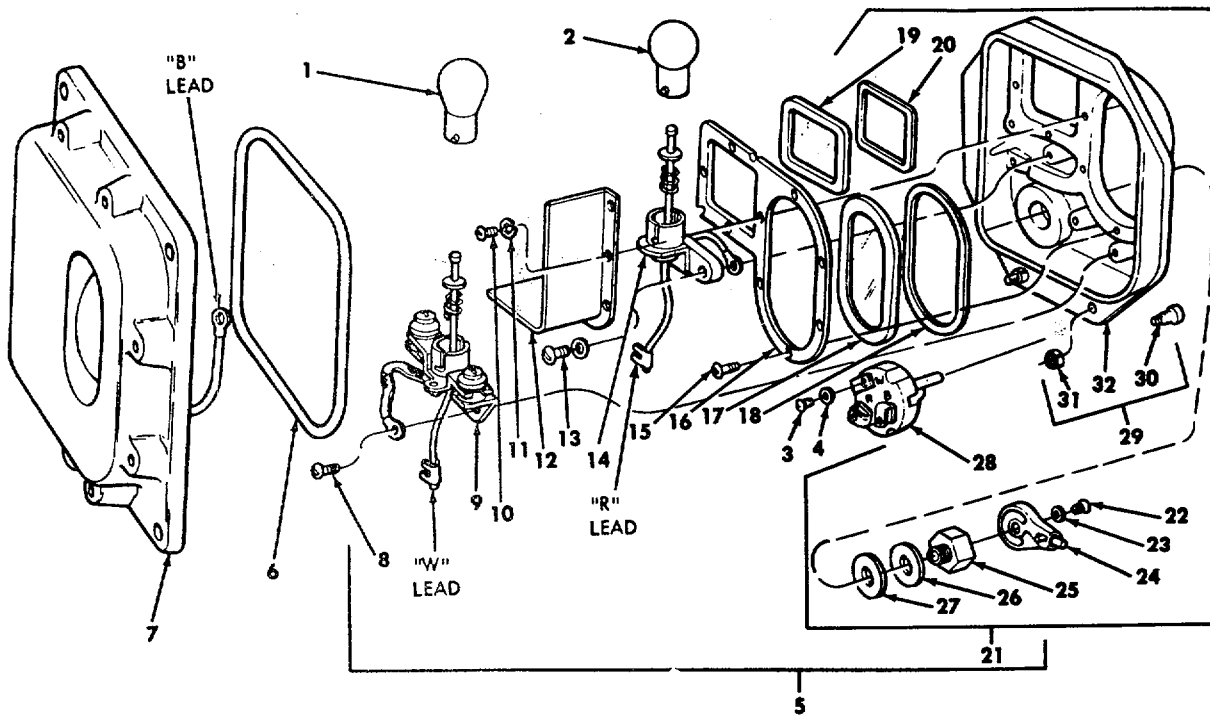
**LEGEND**

- |                               |                     |                        |
|-------------------------------|---------------------|------------------------|
| 1. 15 C.P. LAMP (WHITE LENS)  | 12. PARTITION       | 23. LOCK WASHER        |
| 2. 6 C.P. LAMP (RED LENS)     | 13. SCREW (2)       | 24. KNOB ASSEMBLY      |
| 3. SCREW (3)                  | 14. SOCKET ASSEMBLY | 25. NUT ASSEMBLY       |
| 4. LOCK WASHER (3)            | 15. SCREW (7)       | 26. FLAT WASHER        |
| 5. DOOR - SOCKET - LENS GROUP | 16. RETAINER        | 27. GASKET             |
| 6. DOOR GASKET                | 17. WHITE LENS      | 28. SWITCH             |
| 7. BODY GROUP                 | 18. GASKET          | 29. DOOR ASSEMBLY      |
| 8. SCREW (2)                  | 19. RED LENS        | 30. SCREW (8)          |
| 9. SOCKET ASSEMBLY            | 20. GASKET          | 31. RETAINING RING (8) |
| 10. SCREW (4)                 | 21. DOOR GROUP      | 32. DOOR               |
| 11. LOCK WASHER (4)           | 22. SCREW           |                        |

**DISASSEMBLY**

LOOSEN SCREWS (ITEM 30) AND SEPARATE BODY GROUP (ITEM 7) AND DOOR GASKET (ITEM 6) FROM DOOR GROUP (ITEM 5).

DISASSEMBLY BY FOLLOWING NUMERICAL SEQUENCE.

**ASSEMBLY**

REVERSE DISASSEMBLY PROCEDURE.

ITEM 22: APPLY SEALING COMPOUND 8030-081-2333 TO SCREW THREADS.

WE 12027

Figure 9-96. Disassembly/assembly - dome lights

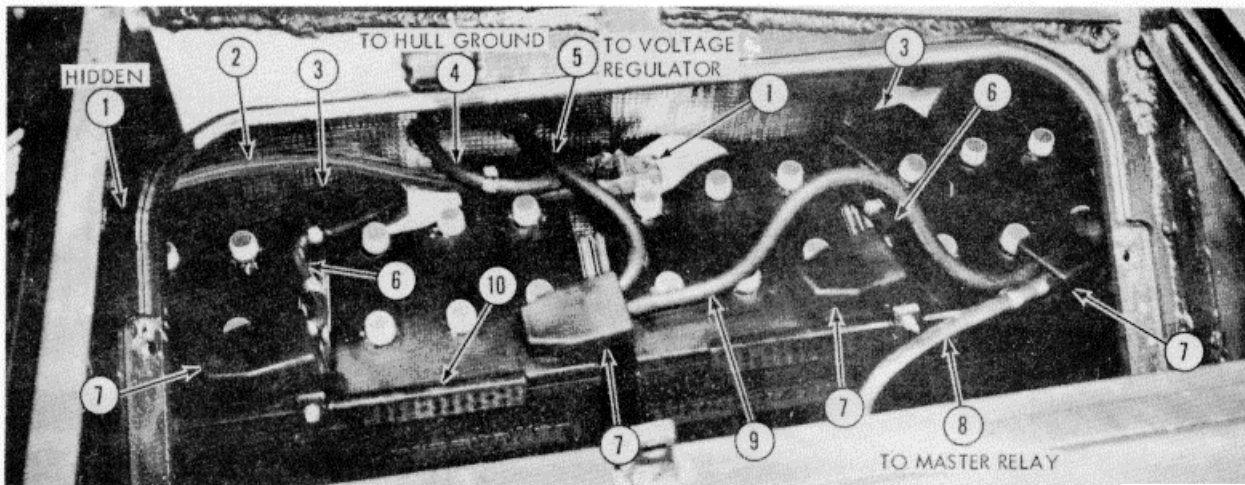

**LEGEND**

1. NEGATIVE TERMINAL ADAPTER (2)
2. JUMPER, NEGATIVE TO NEGATIVE
3. NEGATIVE TERMINAL ADAPTER W/INSULATOR (2)
4. HULL GROUND CABLE # 10
5. VOLTAGE REGULATOR LEAD # 13
6. JUMPER, NEGATIVE TO POSITIVE (2)
7. POSITIVE TERMINAL ADAPTER W/INSULATOR (4)
8. LEADS # 11, # 12B AND # 561
9. JUMPER, POSITIVE TO POSITIVE
10. BATTERY HOLD-DOWN BRACKET GROUP (2)

**REMOVAL**

1. OPEN BATTERY ACCESS COVER, AND REMOVE LATCH PIN AND 6 SCREWS TO REMOVE BATTERY ACCESS DOOR.
2. LOOSEN TERMINAL ADAPTER NUTS AND REMOVE ALL ADAPTERS W/LEADS.
3. REMOVE NUTS AND WASHERS FROM HOLD-DOWN BRACKET RODS AND REMOVE BRACKETS.
4. REMOVE BATTERIES.

**INSTALLATION**

REVERSE REMOVAL PROCEDURE.

**CAUTION:** CHECK ALL CONNECTIONS FOR PROPER POLARITY BEFORE TURNING ON ANY SWITCHES. CHECK THAT ITEM 4 (CIRCUIT #10) IS CONNECTED TO HULL GROUND AND ITEM 5 (CIRCUIT #13) IS CONNECTED TO VOLTAGE REGULATOR. REVERSING THESE CABLES WILL CAUSE SERIOUS DAMAGE TO VOLTAGE REGULATOR.

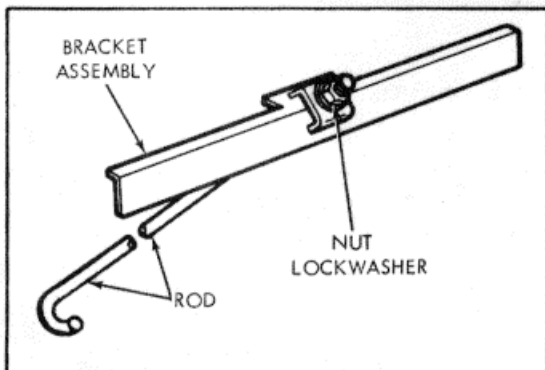

BATTERY HOLD DOWN BRACKET GROUP

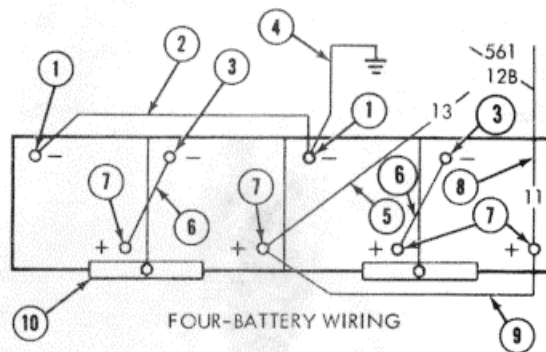

**NOTE.** FOUR BATTERIES ARE REQUIRED

**CONVERSION - TWO TO FOUR BATTERIES**

THE FOLLOWING ADDITIONAL PARTS ARE REQUIRED TO CONVERT TWO-BATTERY INSTALLATION TO FOUR BATTERIES:

BATTERIES (2)	6140-057-2554
ROD	11636145
BRACKET ASSY	2590-911-3629
WASHER	1005-755-4866
NUT	5310-913-7020
TERMINAL ADAPTER (2)	5940-549-6581
TERMINAL ADAPTER (2)	5940-549-6583
LEAD ASSY	6140-926-3370
LEAD ASSY (2)	2590-930-5152
INSULATOR (3)	2590-944-3591

REFER TO TM 9-6140-200-15 FOR ADDITIONAL INFORMATION ON BATTERY MAINTENANCE.

WE 66615

Figure 9-97. Removal/installation - batteries and leads

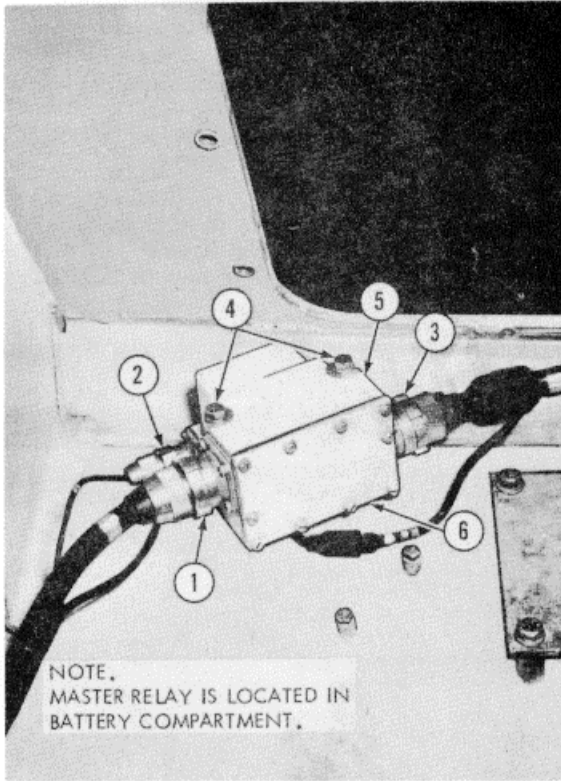

REMOVAL

REMOVE ITEMS IN NUMERICAL SEQUENCE.

1. MASTER RELAY-TO-STARTER CABLE (CIRCUIT NO. 111).
2. MASTER RELAY-TO-MASTER SWITCH CABLE (CIRCUIT NO. 12B).
3. MASTER RELAY-TO-BATTERY CABLE (CIRCUIT NO. 11).
4. MASTER RELAY ATTACHING SCREWS (2), AND FLAT WASHERS (2).
5. MASTER RELAY.
6. LOCK WASHER (2) (BETWEEN RELAY AND MOUNTING PADS)

INSTALLATION

INSTALL ITEMS BY REVERSING NUMERICAL SEQUENCE.

WE 11083

Figure 9-98. Removal/installation - master relay

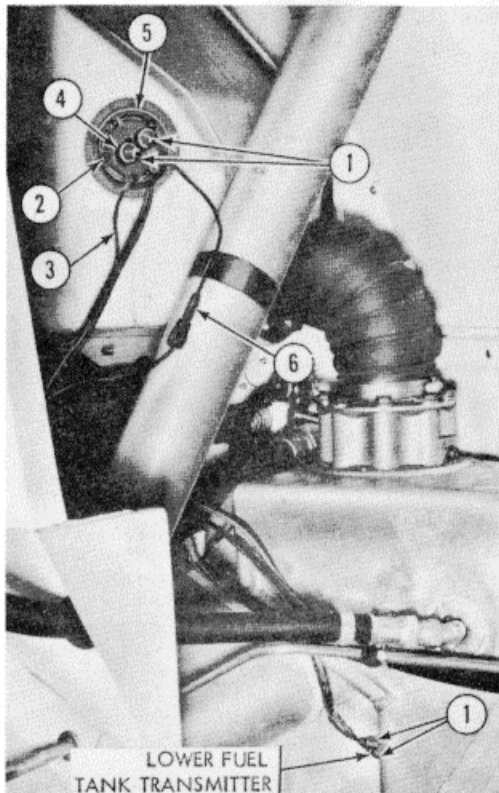

PRELIMINARY STEP

REMOVE AIR INTAKE GRILLE (STEP 1, FIGURE 9-3).

REMOVAL

FOLLOW NUMERICAL SEQUENCE

1. ELECTRICAL LEADS
2. SCREW (5)
3. GROUND LEAD (NO. 30)
4. TRANSMITTER
5. GASKET
6. CONNECTOR W/FUSE

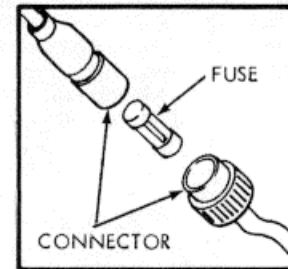

**NOTE.** GROUND LEAD NOT USED ON LOWER FUEL TANK TRANSMITTER

INSTALLATION

REVERSE NUMERICAL SEQUENCE, USE NEW GASKET. DO NOT OVER TIGHTEN SCREWS, BUT TIGHTEN SECURELY TO PREVENT LEAKS. CONNECT LEAD NO. 32A TO UPPER TRANSMITTER AND LEAD NO. 32C TO LOWER TRANSMITTER. CONNECT LEAD NO. 32B TO EACH TRANSMITTER.

**NOTE.** TAPE LEAD ASSEMBLY TO RACE RING SUPPORT AS SHOWN. FUSE MAY BE INSPECTED OR REPLACED BY SEPARATING CONNECTOR, ITEM 6.

REFER TO FIGURE 8-8 AND TABLE 8-11 FOR TROUBLESHOOTING INFORMATION.

WE 11291A

Figure 9-99. Removal/installation - fuel level transmitters



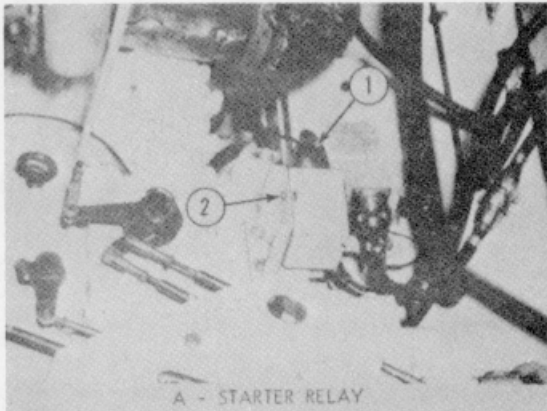

A - STARTER RELAY

**STARTER RELAY**  
**PRELIMINARY STEP**  
 OPEN EXHAUST GRILLES AND REMOVE GRILLE SUPPORT AND ENGINE ACCESS COVER (FIG. 9-3), STEPS 2 THROUGH 5.  
**REMOVAL (VIEW A)**  
 1. LOOSEN NUT AND DISCONNECT STARTER CIRCUIT HARNESS PLUG.  
 2. REMOVE SCREWS, LOCK WASHERS, NUT, AND STARTER RELAY.  
**INSTALLATION**  
 REVERSE REMOVAL PROCEDURE.

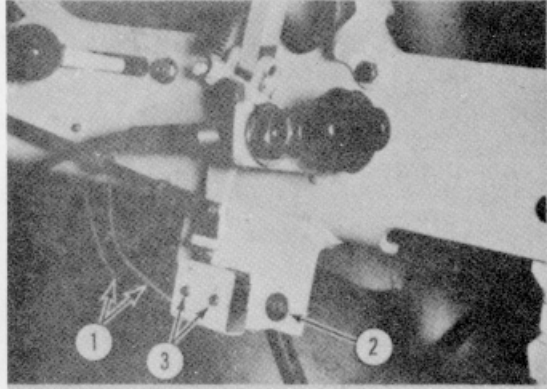

B - NEUTRAL SAFETY SWITCH

**NEUTRAL SAFETY AND WATER STEER SWITCHES**  
**REMOVAL (VIEWS B AND C)**  
 1. DISCONNECT 2 ELECTRIC LEADS AT CONNECTORS.  
 2. REMOVE SCREWS, NUTS, FLAT WASHERS, AND SWITCH ASSY.  
 3. REMOVE TWO SCREWS, WASHERS, SWITCH, AND LEADS (2) FROM BRACKET.  
**INSTALLATION**  
 CONNECT LEADS TO PROPER TERMINALS AS INDICATED IN VIEW BELOW. REVERSE REMOVAL PROCEDURE. APPLY SEALING COMPOUND 8030-081-2336 TO SCREWS IN STEP 3. ADJUST AS INDICATED IN FIGURES 9-47 AND 9-54 RESPECTIVELY.

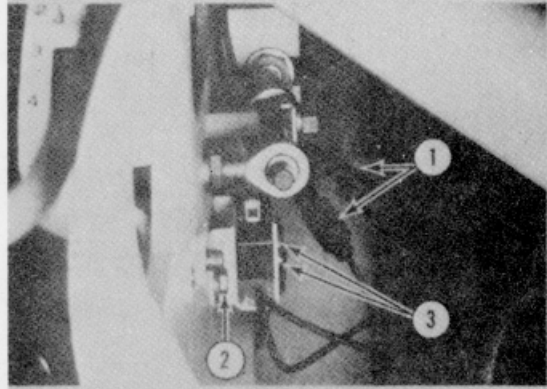

C - WATER STEER SWITCH

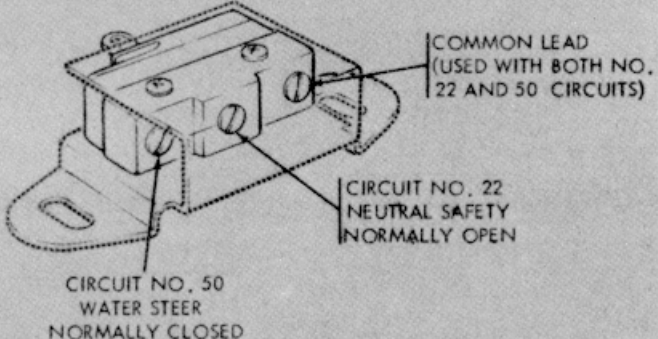

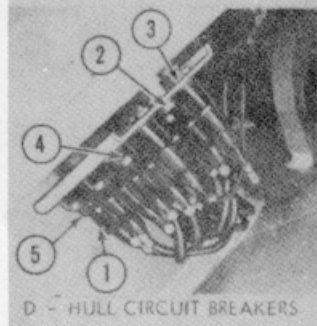

D - HULL CIRCUIT BREAKERS

**HULL CIRCUIT BREAKERS**  
**REMOVAL (VIEW D)**  
 1. ELECTRICAL CONNECTORS (16)  
 2. SCREW (2), FLAT WASHER (2)  
 3. PANEL ASSEMBLY  
 4. SCREW (16), NUT (16), LOCK WASHER (16)  
 5. CIRCUIT BREAKER (8)  
**INSTALLATION**  
 REVERSE REMOVAL PROCEDURE

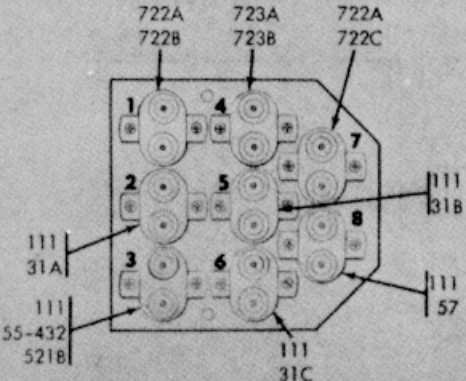

**NOTE. REFER TO TABLE 9-12 FOR IDENTIFICATION OF CIRCUIT BREAKER CIRCUIT NUMBERS.**  
 E - CIRCUIT BREAKER PANEL - REFERENCE, WE 12087

Figure 9-100. Removal/installation starter relay, neutral safety and water steer switches, and hull circuit breakers

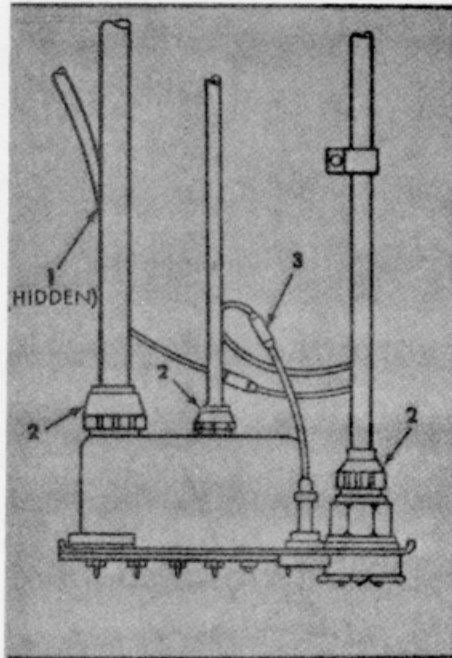

A. HARNESS CONNECTIONS AT DRIVER'S SWITCH PANEL.

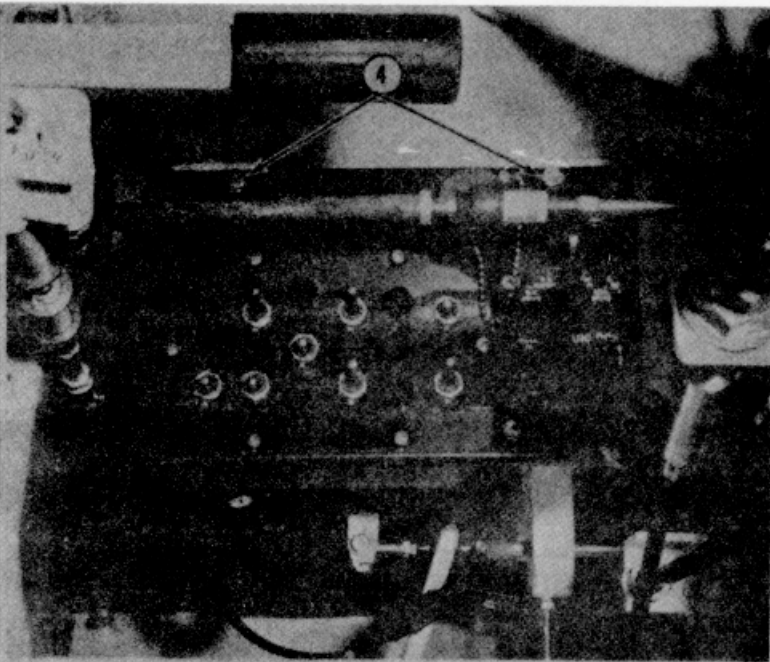

B. DRIVER'S SWITCH PANEL - INSTALLED VIEW

#### REMOVAL

1. UNSCREW NUT AND DISCONNECT HULL FRONT POWER BRANCHED WIRING HARNESS AT REAR OF DRIVER'S SWITCH PANEL.
2. UNSCREW NUTS AND DISCONNECT HULL FRONT INDICATOR BRANCHED WIRING HARNESS AND LIGHT SWITCH HARNESS, AND TURRET-POWER RELAY LEAD.
3. DISCONNECT CONNECTOR AT LEAD TO AUXILIARY OUTLET.
4. REMOVE 4 SCREWS, FLAT WASHERS, AND DRIVER'S SWITCH PANEL.

#### INSTALLATION

REVERSE REMOVAL PROCEDURE.

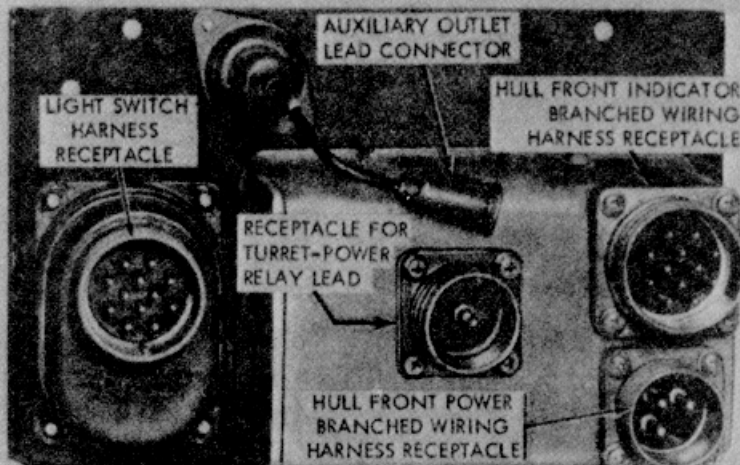

C. HARNESS DISCONNECT POINTS AT REAR OF DRIVER'S SWITCH PANEL.

TA007331

Figure 9-101. Removal/installation - driver's switch panel

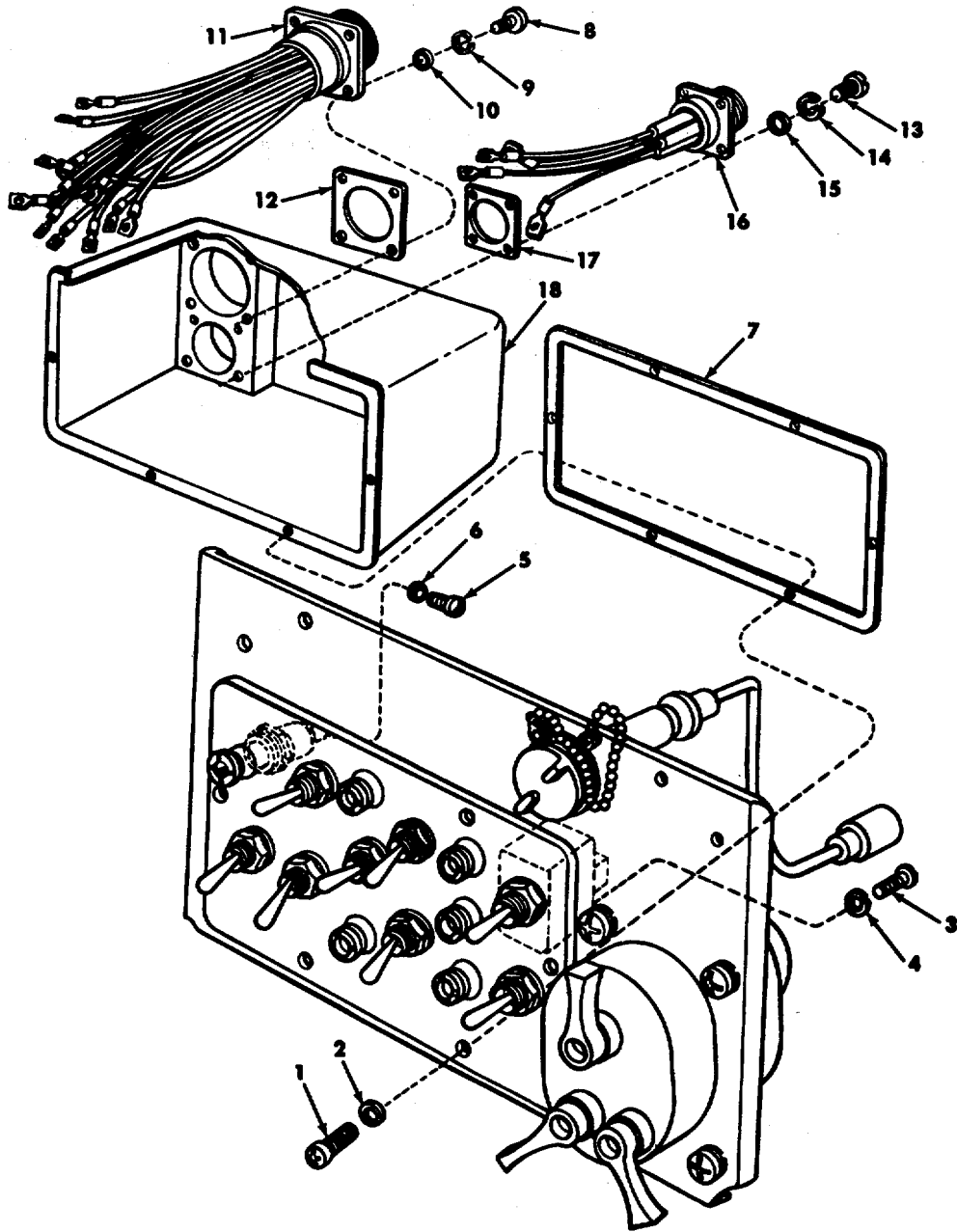

**LEGEND**

- |                     |                     |
|---------------------|---------------------|
| 1. SCREW (6)        | 10. FLAT WASHER (4) |
| 2. FLAT WASHER (6)  | 11. LEAD ASSEMBLY   |
| 3. SCREW (18)       | 12. GASKET          |
| 4. LOCK WASHER (18) | 13. SCREW (4)       |
| 5. SCREW (6)        | 14. LOCK WASHER (4) |
| 6. LOCK WASHER (6)  | 15. FLAT WASHER (4) |
| 7. COVER GASKET     | 16. LEAD ASSEMBLY   |
| 8. SCREW (4)        | 17. GASKET          |
| 9. LOCK WASHER (4)  | 18. COVER           |

**DISASSEMBLY**

REMOVE IN NUMERICAL SEQUENCE.

**ASSEMBLY**

REVERSE NUMERICAL SEQUENCE.

WE 11022

Figure 9-102. Disassembly/assembly - driver's stitch panel (1 of 2)



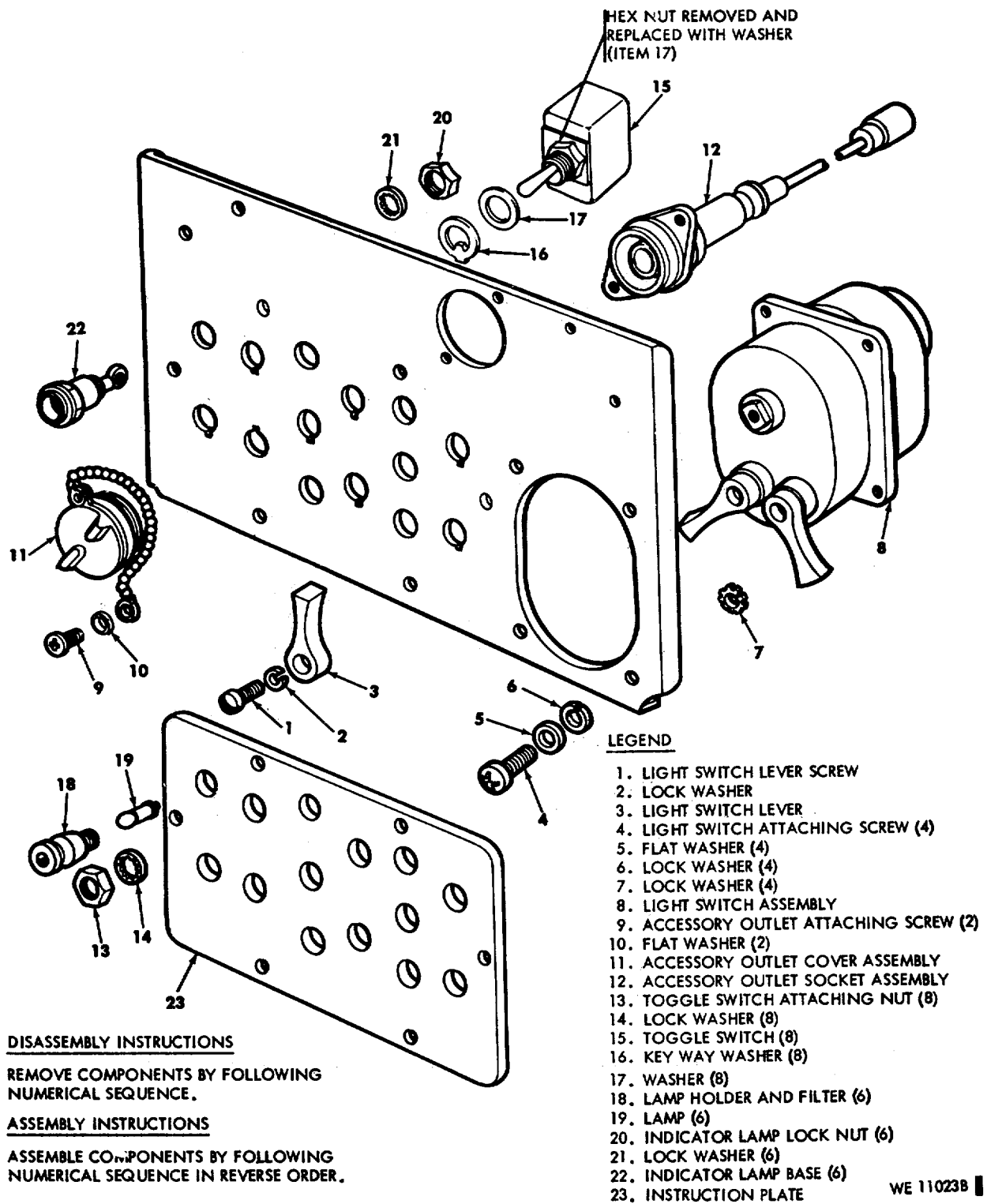
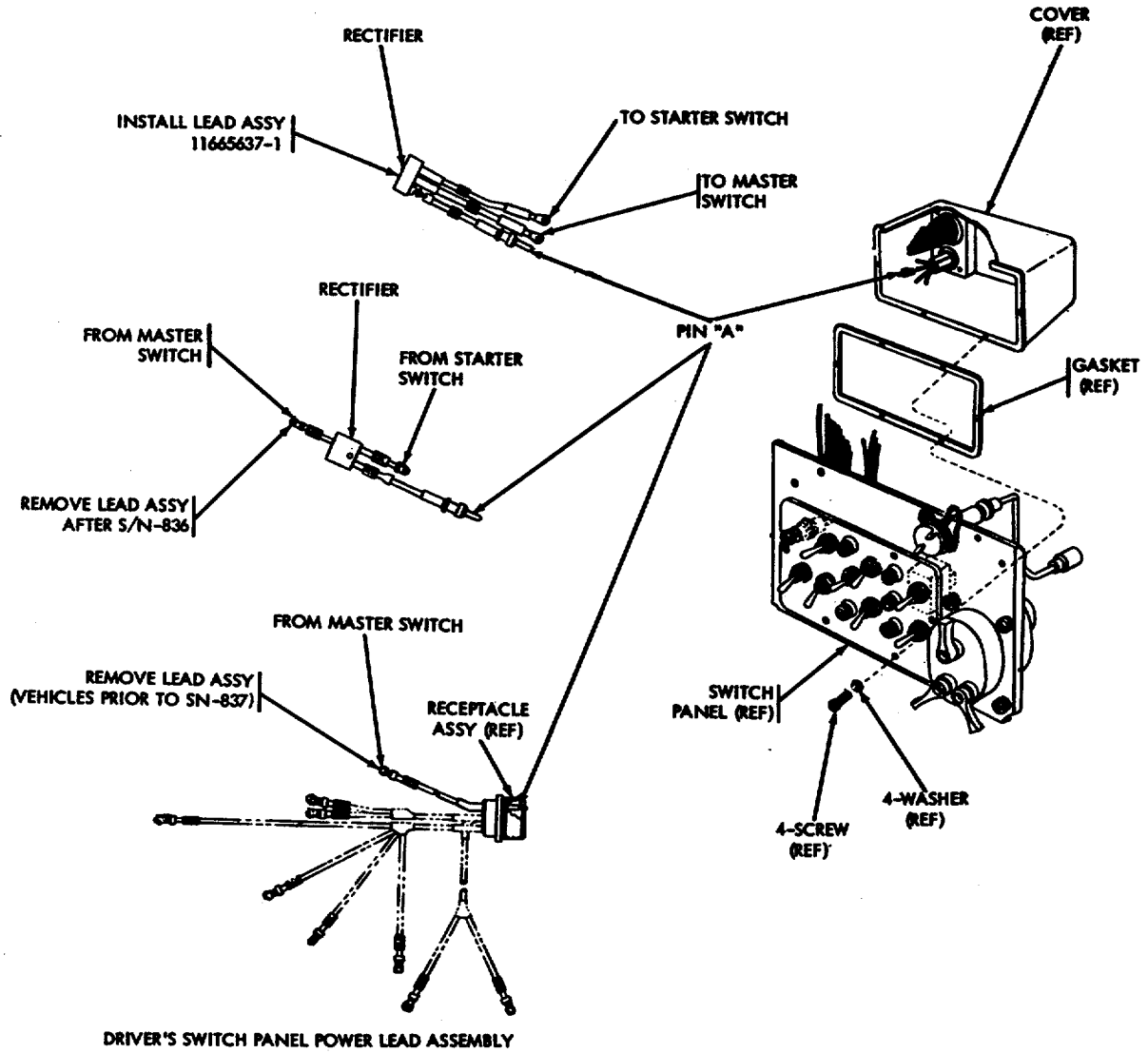

Figure 9-103. (Superseded) Disassembly/assembly - driver's switch panel (2 of 2)



AT 35870

Figure 9-103.1. Removal/installation - driver's switch panel rectifier.

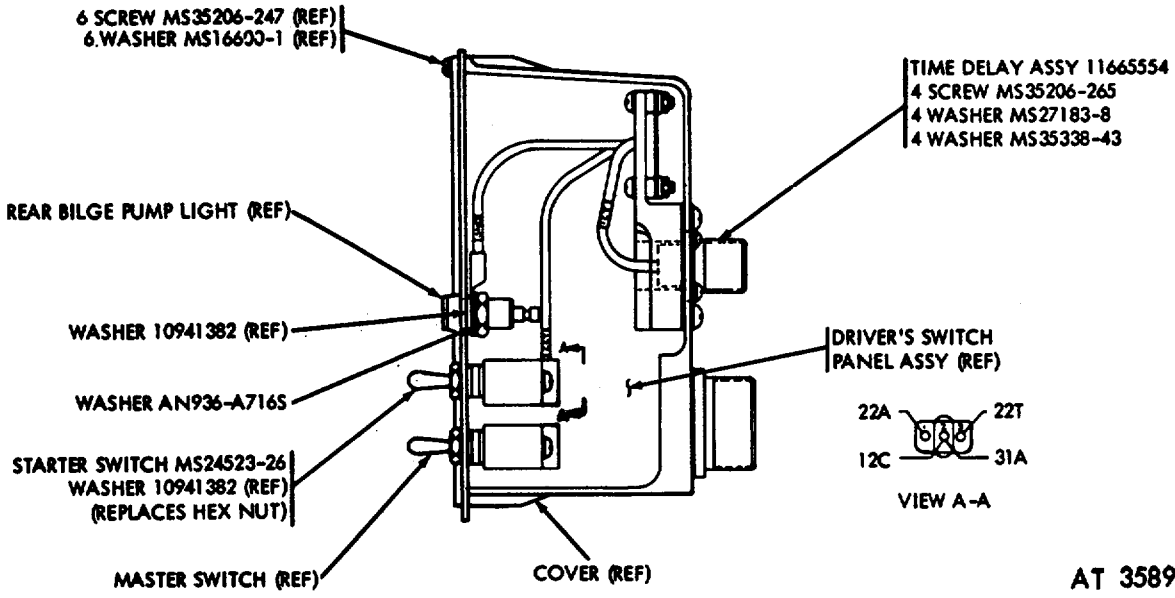
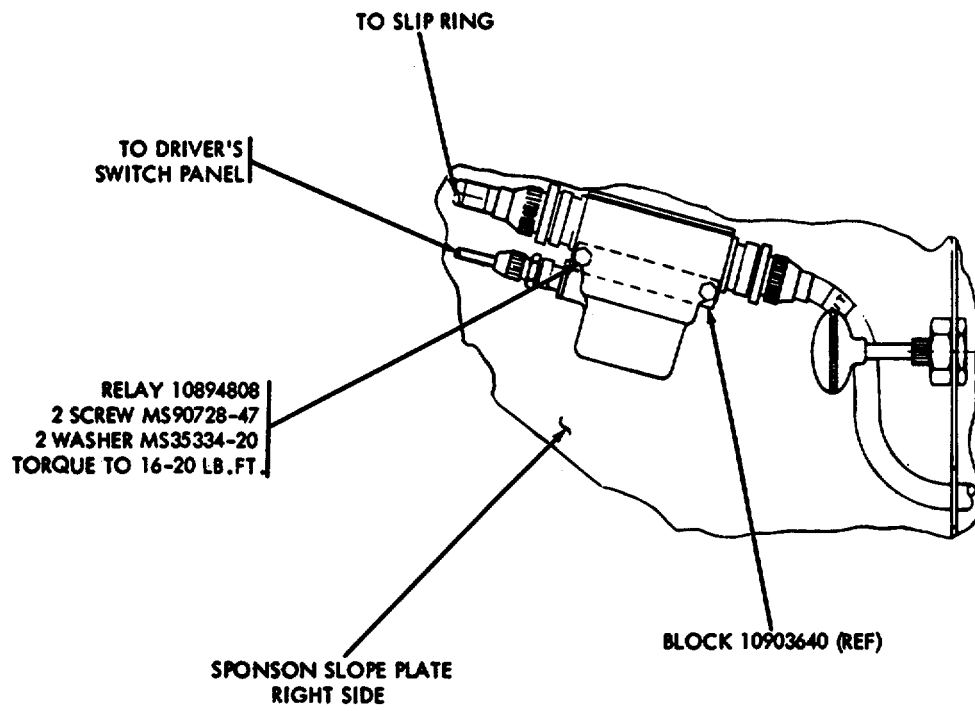

Figure 9-103.2. Removal/installation - time delay assembly.

9-110.2



AT 35811

Figure 9-103.3. Removal/installation - turret master relay.

9-110.3

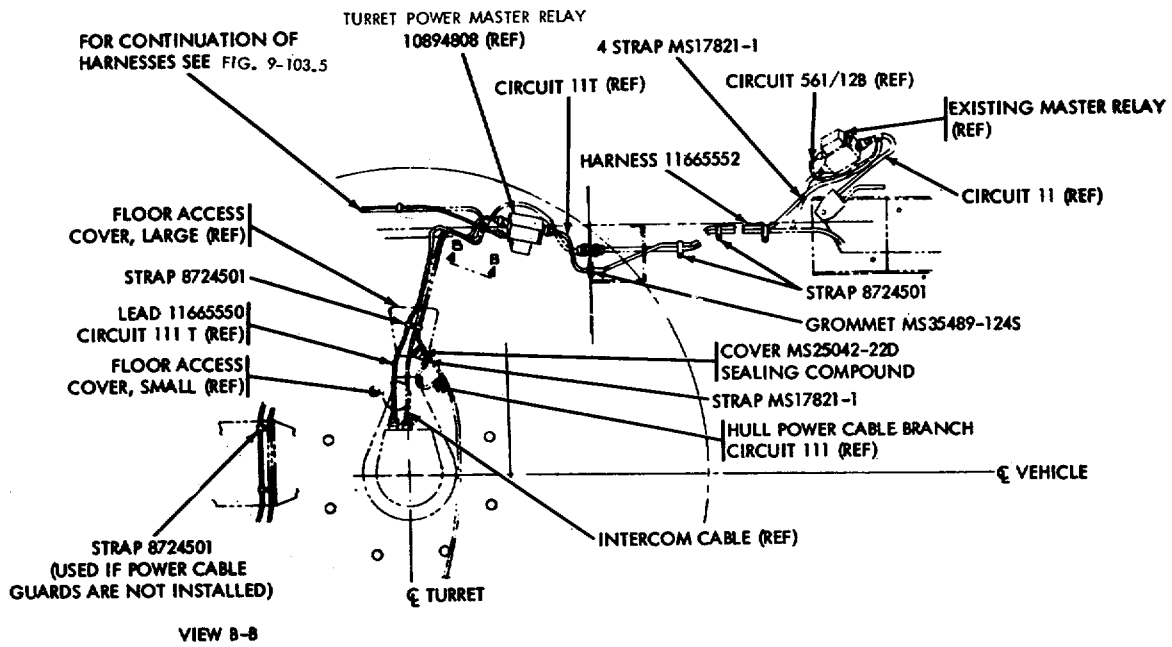

AT 35812

Figure 9-103.4. Removal/installation - electrical harnesses (1 of 2).

9-110.4

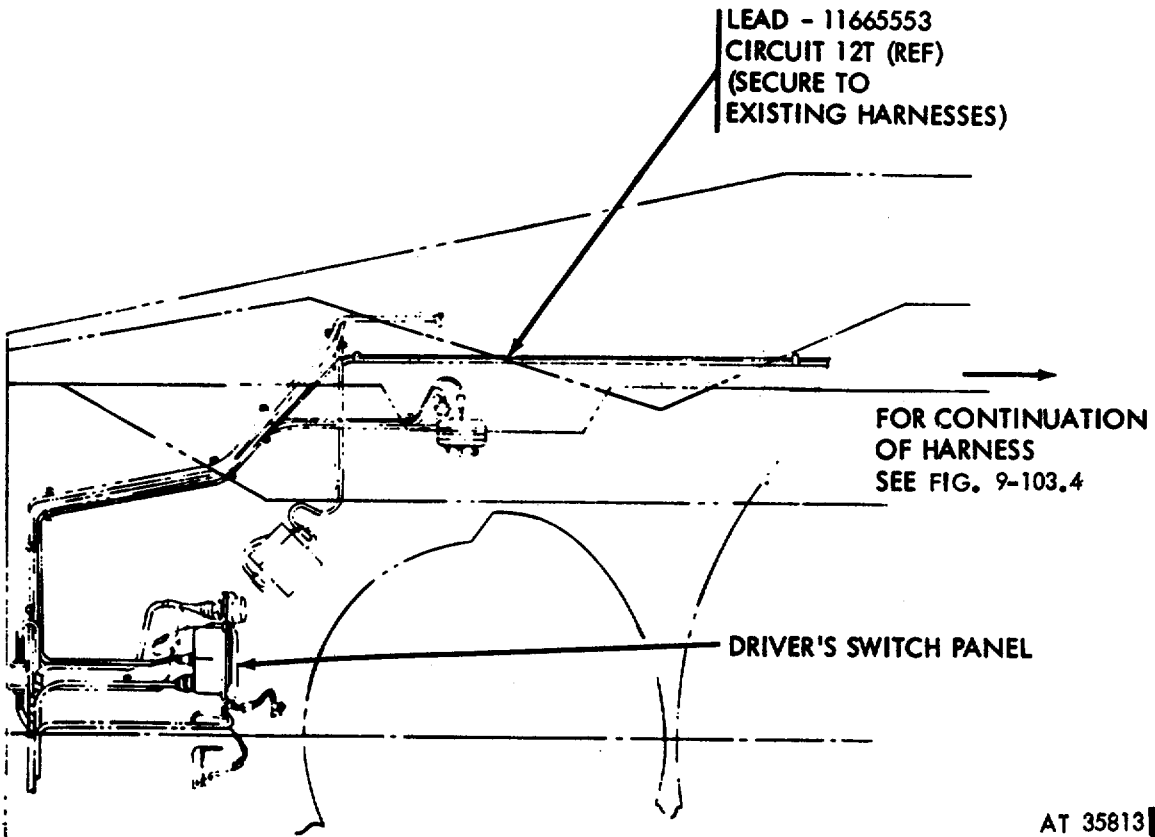
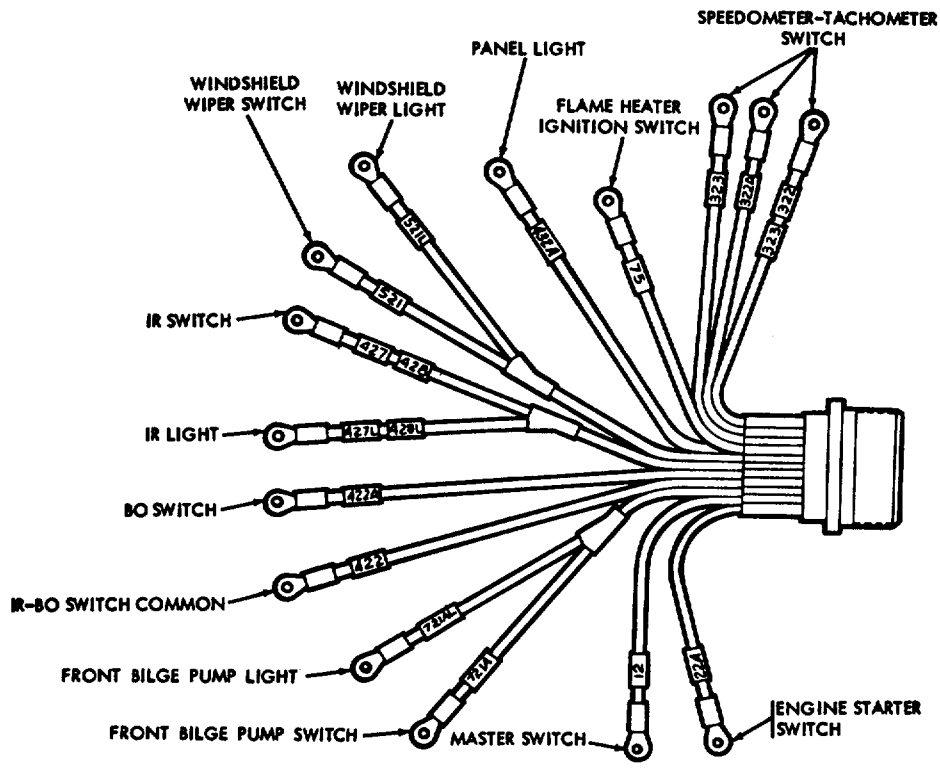
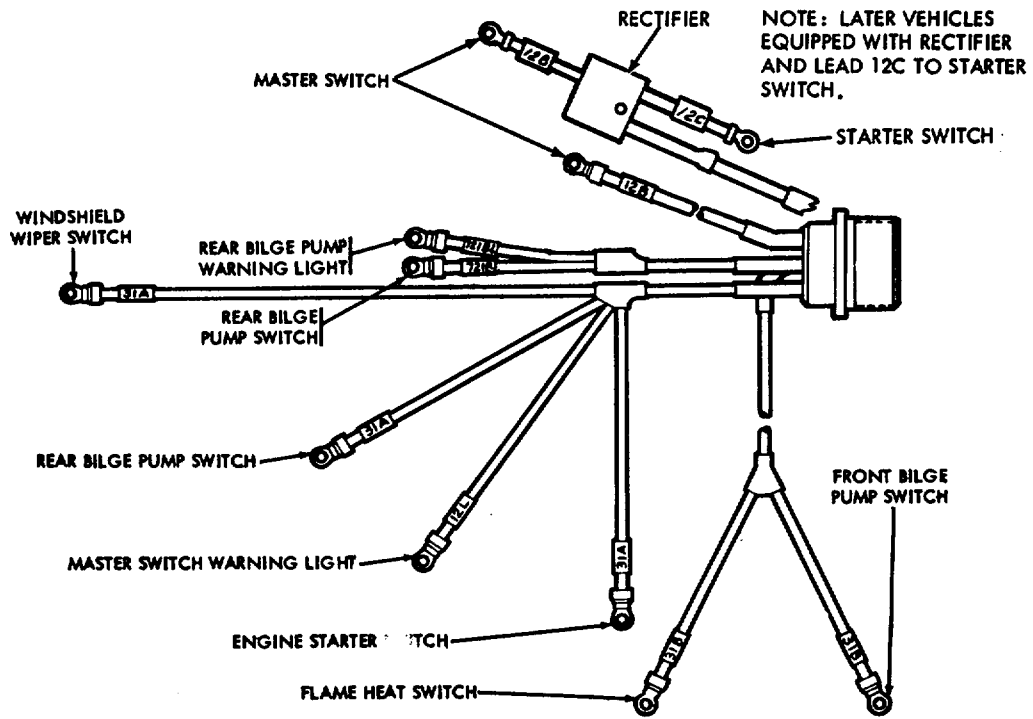

Figure 9-103.5. Removal/installation - electrical harnesses (2 of 2).

(9-110.6 blank)/9-110. 5



A. DRIVER'S SWITCH PANEL LEAD ASSEMBLY



B. DRIVER'S SWITCH PANEL POWER LEAD ASSEMBLY

WE 11231A

Figure 9-104. Driver's switch panel - lead connection guide

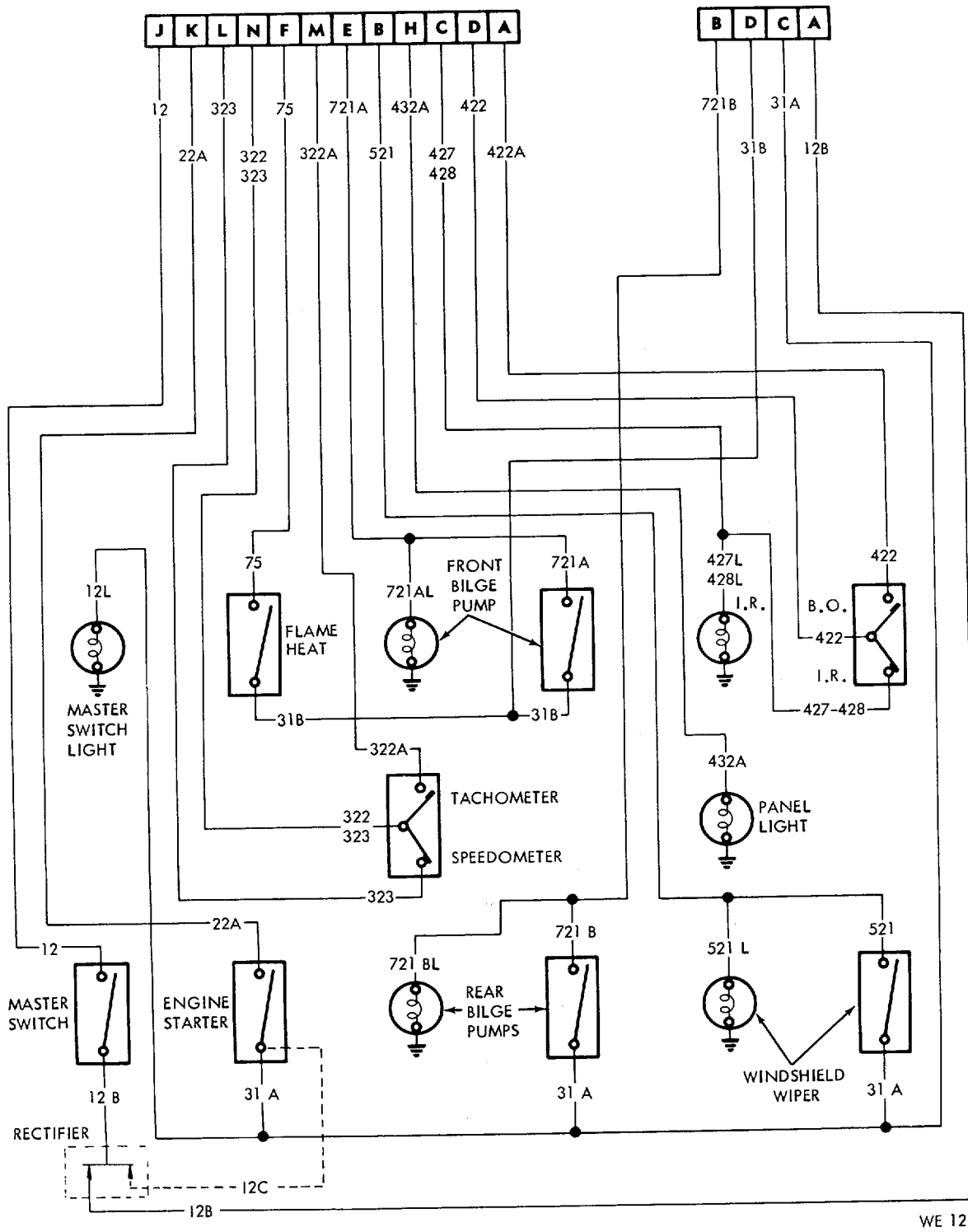

WE 12174

Figure 9-105. Schematic wiring diagram - driver's switch panel



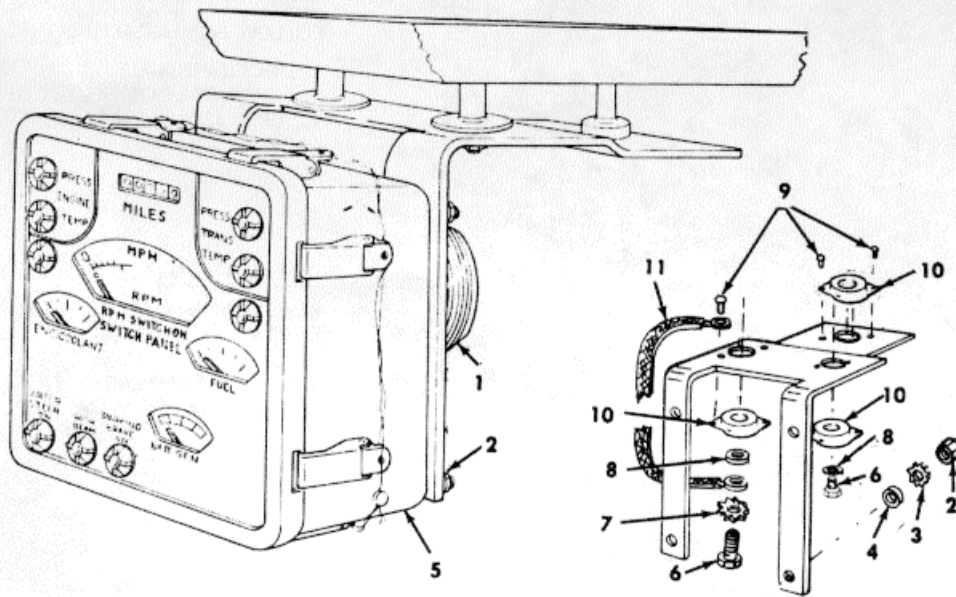

- |                         |                    |                  |
|-------------------------|--------------------|------------------|
| 1. ELECTRICAL CONNECTOR | 5. INDICATOR PANEL | 9. RIVET (6)     |
| 2. NUT (4)              | 6. SCREW (3)       | 10. CUSHION (3)  |
| 3. LOCK WASHER (4)      | 7. WASHER          | 11. GROUND STRAP |
| 4. WASHER (4)           | 8. WASHER (3)      |                  |

REMOVAL/DISASSEMBLY

FOLLOW NUMERICAL SEQUENCE. USE PLIERS 5120-624-8065 TO DISCONNECT ELECTRICAL CONNECTOR.

ASSEMBLY/INSTALLATION

REVERSE REMOVAL/DISASSEMBLY PROCEDURE. REPLACE UNSERVICEABLE PARTS AS REQUIRED.

NOTE. ORGANIZATIONAL MAINTENANCE OF THE PANEL IS LIMITED TO REPLACEMENT OF LENS CAPS, GASKETS AND INCANDESCENT LAMPS. DO NOT DISASSEMBLE PANEL FOR FURTHER MAINTENANCE.

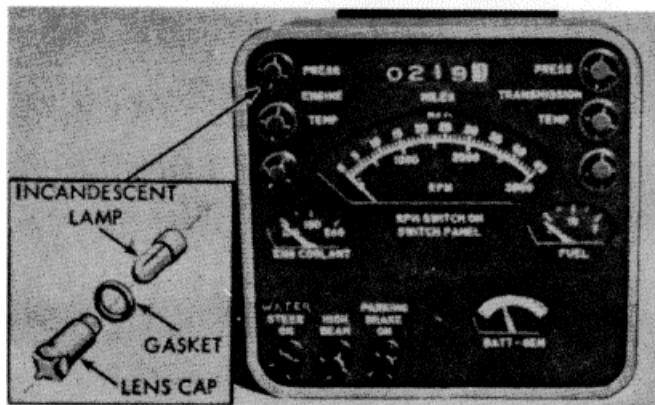

LAMP REPLACEMENT

LAMP REPLACEMENT

1. UNSCREW LENS AND REMOVE COMBINED CAP, GASKET, AND INCANDESCENT LAMP FROM PANEL.
2. PULL INCANDESCENT LAMP FROM LENS CAP TO REPLACE.

WE 66581

Figure 9-106. Removal/installation - driver's indicator panel

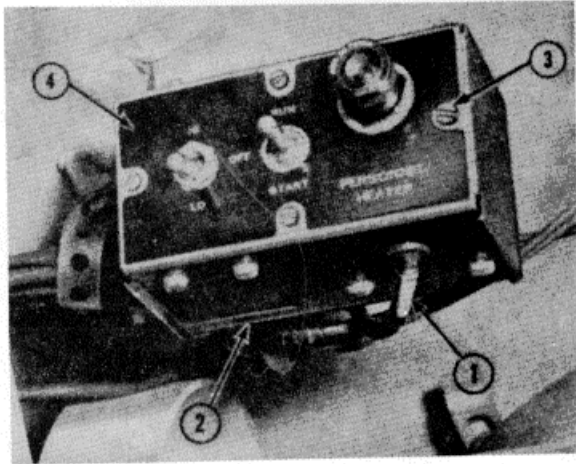

VIEW A - VEHICLES THROUGH SN 797

REMOVAL (ALL VEHICLES)

FOLLOW NUMERICAL SEQUENCE.

1. DISCONNECT ELECTRICAL LEAD (CIRCUIT NO. 561)
2. ELECTRICAL CONNECTOR (HIDDEN)
3. SCREW (2)
4. PANEL ASSEMBLY

INSTALLATION (ALL VEHICLES)

REVERSE NUMERICAL SEQUENCE.

REFER TO FIGURE 9-107.1 FOR DISASSEMBLY/ASSEMBLY. REPLACE UNSERVICEABLE COMPONENTS AS REQUIRED. LAMP CAN BE REPLACED WITHOUT REMOVING PANEL ASSEMBLY BY REMOVING CAP.

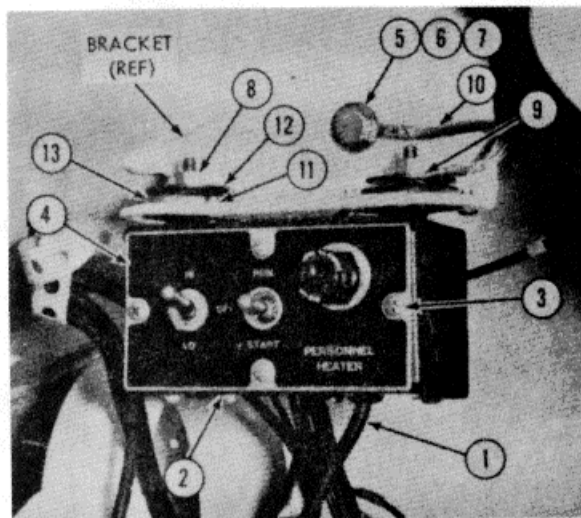

VIEW B - VEHICLES AFTER SN 797

REPAIR OF MOUNT  
(VEHICLES AFTER SN 797)LEGEND

5. SCREW
6. FLAT WASHER
7. EXTERNAL TOOTH WASHER
8. NUT (2)
9. EXTERNAL TOOTH WASHER
10. GROUND STRAP
11. RIVET (4) (MS24662-77)
12. FLAT WASHER (2)
13. CUSHION (2)

REPLACE UNSERVICEABLE PARTS AS REQUIRED. EXTERNAL TOOTH WASHER (7) MUST BE INSTALLED BETWEEN GROUND STRAP TERMINAL AND BRACKET.

WE 12196

Figure 9-107. Removal/installation - personnel heater control box assembly

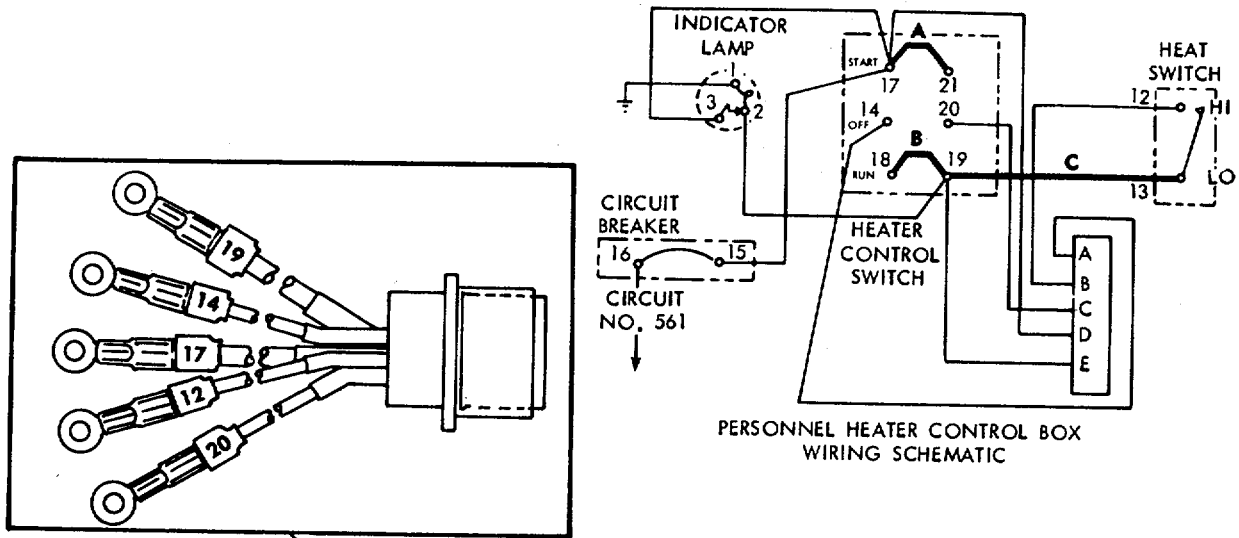

PERSONNEL HEATER CONTROL BOX WIRING SCHEMATIC

DISASSEMBLY/ASSEMBLY

FOLLOW NUMERICAL SEQUENCE FOR TOTAL DISASSEMBLY. REVERSE SEQUENCE FOR ASSEMBLY.

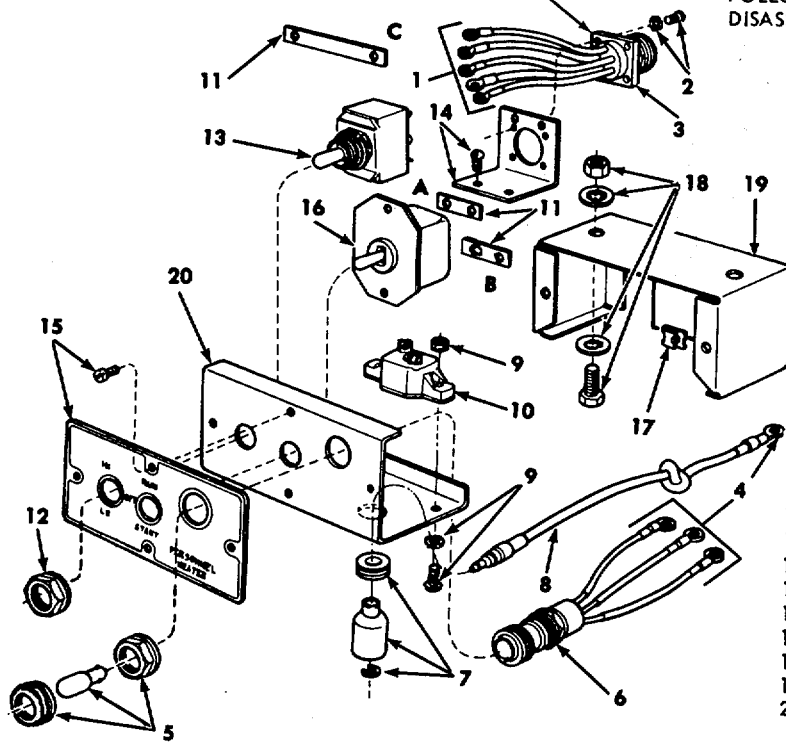

LEGEND

1. FIVE SCREWS AND ELECTRICAL LEADS  
NOTE. REINSTALL SCREWS.
2. FOUR SCREWS AND WASHERS
3. LEAD ASSEMBLY
4. FOUR SCREWS AND ELECTRICAL LEADS  
NOTE. REINSTALL SCREWS
5. CAP, LAMP, AND NUT
6. INDICATOR LIGHT
7. LOCK WASHER, SHELL, AND GROMMET
8. ELECTRICAL LEAD
9. TWO SCREWS, WASHER, AND NUTS
10. CIRCUIT BREAKER
11. SCREWS (6) AND JUMPER STRAPS (A, B, & C). REINSTALL SCREWS IN SWITCHES, ITEMS 13 AND 16.
12. NUT
13. "HI-LO" SWITCH
14. SCREWS (4) AND BRACKET
15. SCREWS (2) AND SWITCH PANEL
16. "START-RUN" SWITCH
17. NUTS (2)
18. SCREWS (2), WASHERS (4), AND NUTS (2)
19. CONTROL BOX CASE ASSEMBLY
20. CONTROL BOX PANEL

WE 12197

Figure 9-107.1 Disassembly / assembly - personnel heater control box assembly

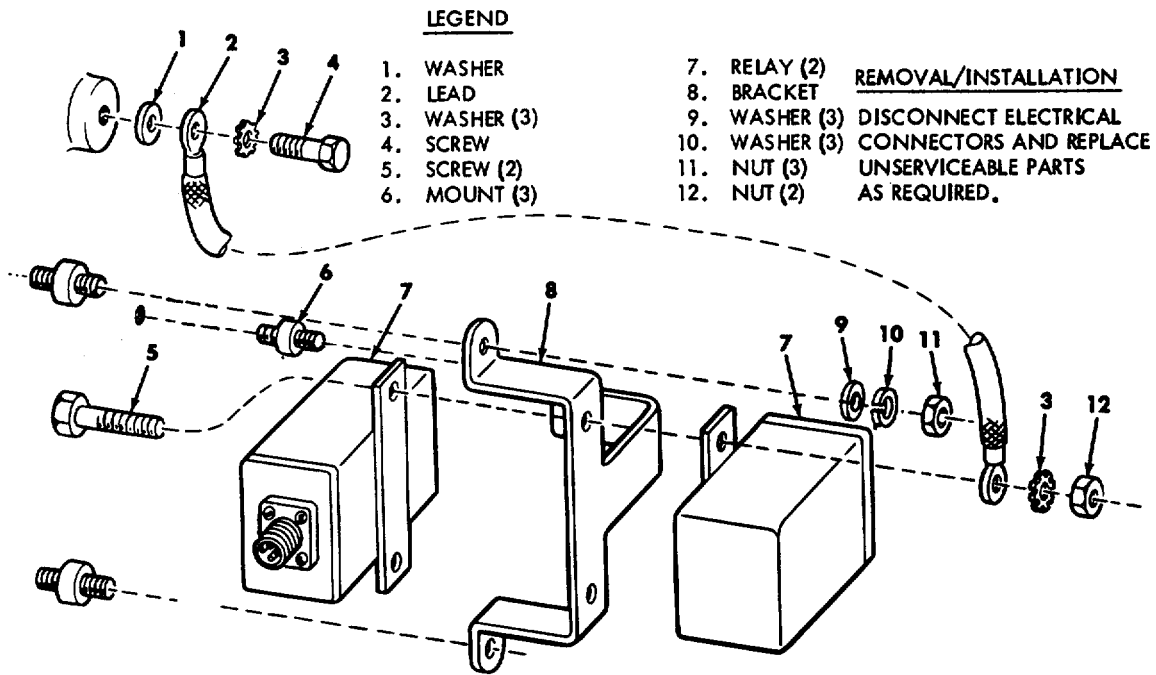

FOR BILGE PUMP  
RELAY LOCATION  
SEE ITEM 13, FIG. 9-82

WE 10987

Figure 9-108. Removal/installation - bilge pump relays and mount

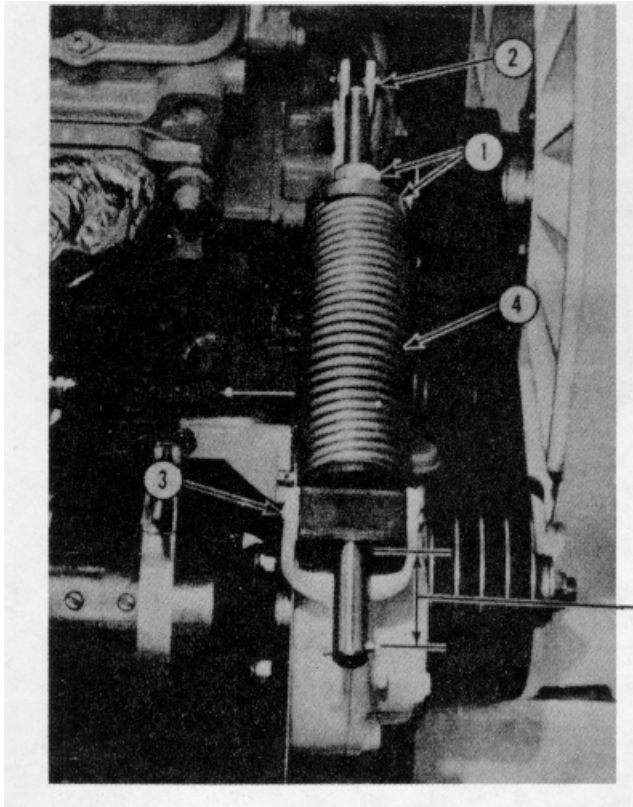

PRELIMINARY STEP

OPEN RIGHT HAND EXHAUST GRILLE.

REMOVAL

1. BACK OFF ADJUSTING NUT AND ADJUSTER (1) TO END OF ROD

**CAUTION:** WHEN BELTS ARE TO BE REMOVED, SUPPORT GENERATOR BEFORE REMOVING TENSIONER.

2. COTTER PIN, WASHER, AND STRAIGHT PIN

3. SCREW (2)

4. BELT TENSIONER

INSTALLATION

REVERSE REMOVAL PROCEDURE. TIGHTEN ADJUSTER (1) UNTIL SPRING IS FULLY COMPRESSED.

NOTE. TENSIONER IS SELF ADJUSTING. REPLACE BELTS IF PIN IS WITHIN 1/4 INCH FROM BOTTOMING OUT. WHEN REPLACING BELTS, ALWAYS REPLACE THE COMPLETE SET OF FOUR.

WE11036A|

Figure 9-109. Removal/installation - generator "V" belt tensioner

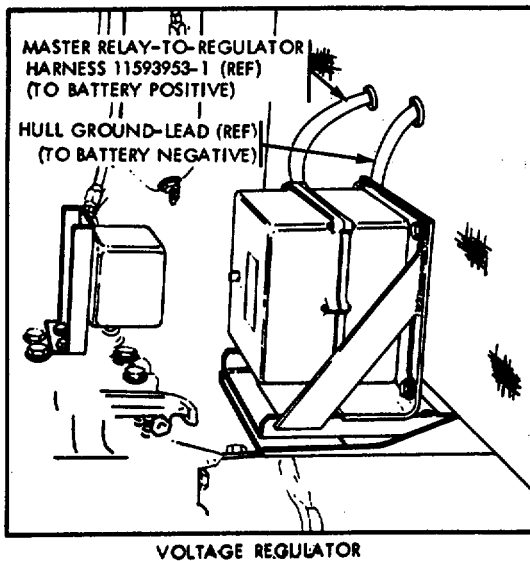

**PRELIMINARY STEP**

OPEN RIGHT EXHAUST GRILLE DOOR. VOLTAGE REGULATOR IS LOCATED ON RIGHT SIDE OF ENGINE COMPARTMENT.

**REMOVAL**

1. LOOSEN NUTS AND DISCONNECT GENERATOR HARNESS PLUG AND BATTERY HARNESS PLUG AT VOLTAGE REGULATOR.
2. REMOVE 4 SCREWS AND LOCK WASHERS AND REMOVE VOLTAGE REGULATOR FROM 2 MOUNTING BRACKETS.

**INSTALLATION**

1. REMOVE ANY FINISH FROM MOUNTING SURFACES.
2. MOUNT TOOTH LOCK WASHER ON TOP OF GROUND WIRE TERMINAL.
3. REVERSE REMOVAL STEPS.

**ADJUSTMENT**

BEFORE ADJUSTING REGULATOR, MAKE SURE THE PROBLEM IS NOT FAIL SAFE LOCKOUT. (SEE TABLE 8-7).

**PRELIMINARY STEPS**

1. CHECK BATTERIES FOR STATE OF CHARGE.
2. IF BATTERIES ARE DEPLETED OR BELOW 1.225 GRAVITY READING, RUN ENGINE AT 1000 TO 1200 RPM FOR APPROXIMATELY 1/2 HOUR TO CHARGE BATTERIES PREPARATORY TO ADJUSTING VOLTAGE RHEOSTAT.
3. MAKE SURE ALL MAJOR VEHICLE ELECTRICAL COMPONENTS ARE TURNED OFF WHILE CHARGING BATTERIES.

**CAUTION:** DO NOT REMOVE REGULATOR COVER. REPLACE PLUG (STEP 5, FIG. 9-110.1) IMMEDIATELY AFTER MAKING ADJUSTMENT.

**NOTE:** REFER TO FIGURE 8-4 FOR VOLTAGE REGULATOR TESTS AND TABLE 8-7 FOR TROUBLE-SHOOTING DATA.

ADJUSTMENT PROCEDURE CONTINUED ON FIG. 9-110.1.

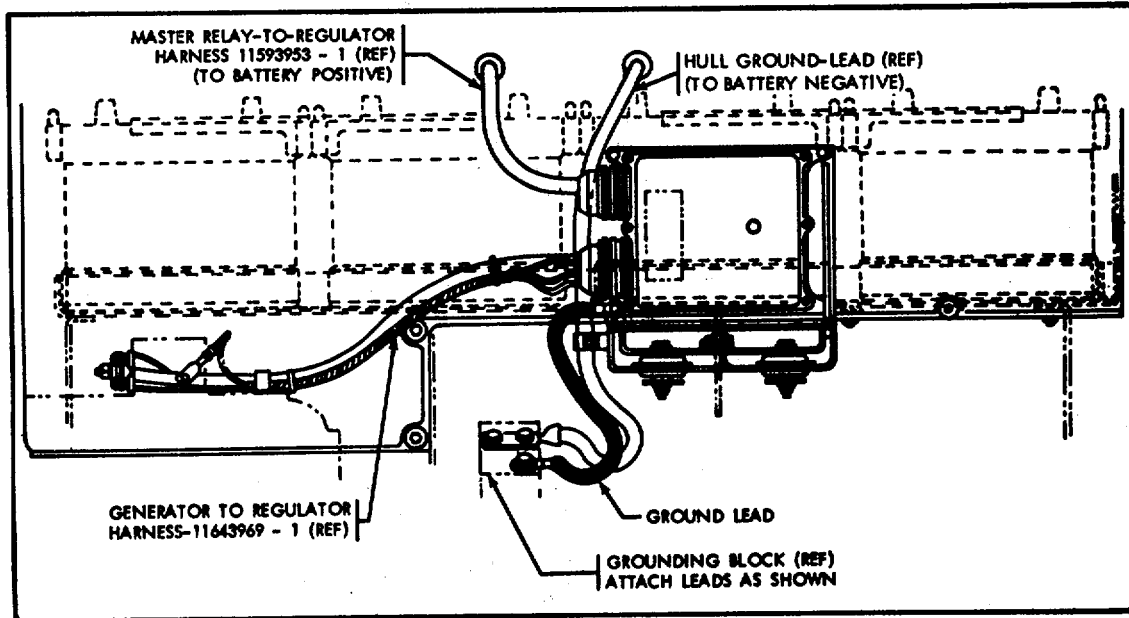

TA007332

Figure 9-110. Removal/installation/adjustment - voltage regulator (1 of 2).

**ADJUSTMENT PROCEDURE**

1. REMOVE PLUG FROM TOP OF VOLTAGE REGULATOR.
2. ATTACH VOLTMETER TO THE POSITIVE AND NEGATIVE BATTERY CABLE TERMINALS.
3. WITH HEADLIGHTS ON, RUN ENGINE AT 1000 RPM. ALLOW 10 MINUTES FOR THE BATTERIES AND VOLTAGE REGULATOR TO STABILIZE BEFORE MAKING ADJUSTMENT.
4. USING A SCREWDRIVER, ADJUST THE RHEOSTAT TO OBTAIN THE VOLTMETER READINGS SHOWN BELOW:

AMBIENT TEMPERATURE	VOLTMETER READING
ABOVE 80°	27.0 - 27.5 SEE
0° to 80°	27.5 - 28.0 NOTE
BELOW 0°	28.0 - 28.5

NOTE. IF BATTERIES REQUIRE EXCESSIVE ADDITION OF WATER, ADJUST VOLTAGE REGULATOR TO 26.5 VOLTS. (AT 26.5 VOLTS, BATTERIES MAY RECEIVE LESS THAN FULL CHARGE IF VEHICLE IS OPERATED INFREQUENTLY OR ONLY FOR SHORT PERIODS.)

5. APPLY SEALING COMPOUND 8030-226-6436 TO PLUG THREADS, AND REPLACE PLUG IN TOP OF VOLTAGE REGULATOR.
6. REMOVE VOLTMETER AND TURN HEADLIGHTS OFF.

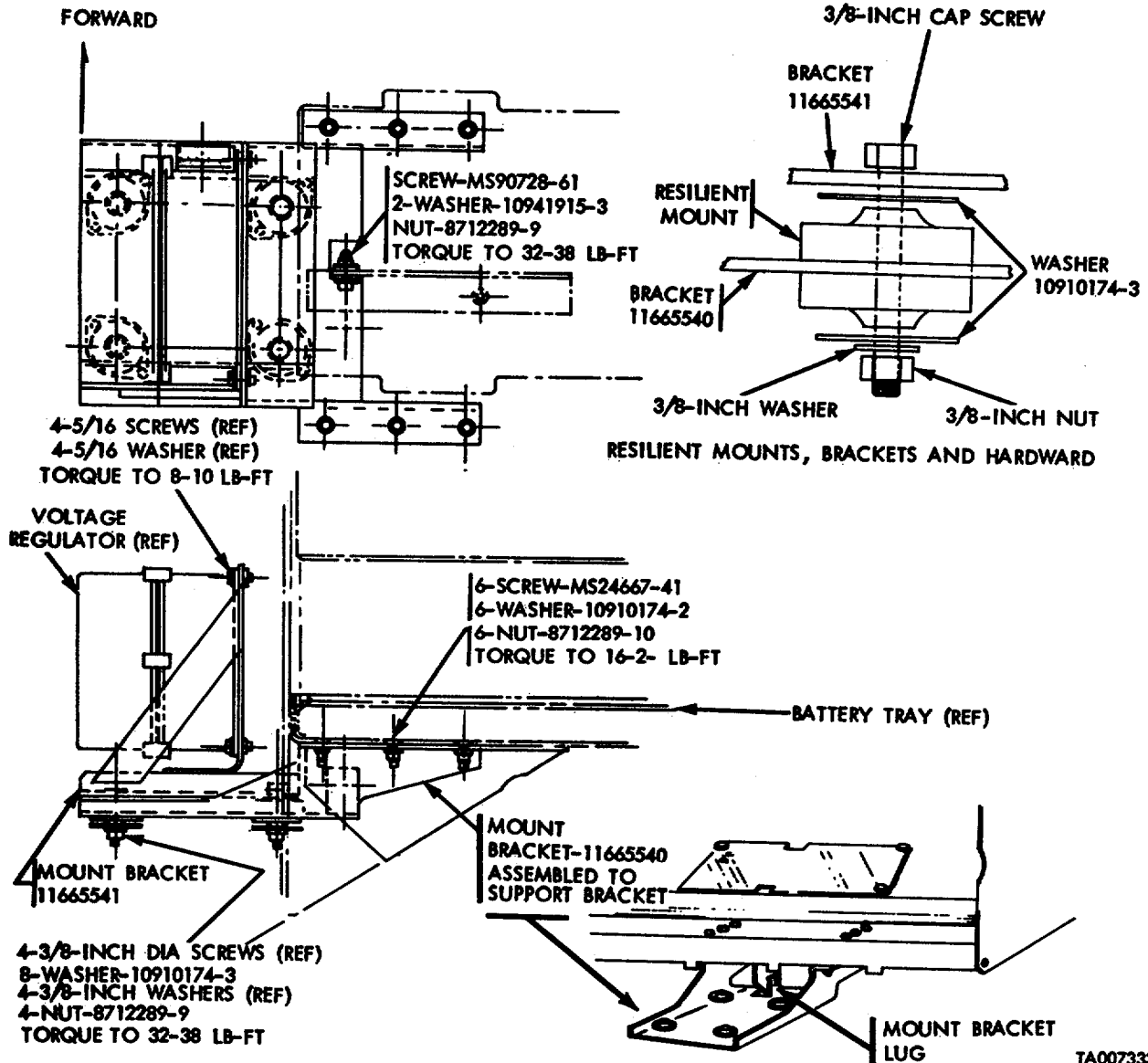

Figure 9-110. 1. Removal/installation/adjustment -voltage regulator (2 of 2).

PRELIMINARY STEPS

- A. SUITABLE HOIST AND SLINGS MUST BE AVAILABLE TO LIFT GENERATOR FROM VEHICLE.
- B. REMOVE HULL ACCESS PLUG UNDER RIGHT ENGINE MOUNTING SCREW (ITEM 6, FIGURE 5-7). PLACE BLOCKING APPROXIMATELY 8 INCHES HIGH ON HULL FLOOR UNDER GENERATOR CRADLE. (IF POWER PLANT IS OUT OF VEHICLE, USE SUITABLE BLOCKING UNDER CRADLE TO PREVENT CRADLE FROM DROPPING BELOW LEVEL POSITION).

REMOVAL

1. DISCONNECT GROUND STRAP AND ELECTRICAL LEADS, CIRCUITS 14, 15, AND 152, AT GENERATOR TERMINAL BOX.
2. LOOSEN BELT TENSIONER (FIGURE 9-109) AND REMOVE BELTS.
3. REMOVE TWO SCREWS AND REMOVE BELT TENSIONER FROM GENERATOR DRIVE HOUSING.
4. PLACE SLING AROUND FRONT END OF GENERATOR NEXT TO GENERATOR DRIVE HOUSING. CONNECT HOIST TO SLING AND REMOVE SLACK.
5. REMOVE CLIP AND WASHER FROM GENERATOR SUPPORT ROD.
6. UNSCREW RETAINING CLAMP NUTS AND RELEASE CLAMPS. RELEASE TENSION ON HOIST UNTIL GENERATOR PULLEYS WILL CLEAR FAN STATOR, THEN SLIDE GENERATOR FORWARD UNTIL HOUSING CLEARS SUPPORT ROD.
7. RELEASE TENSION ON HOIST UNTIL GENERATOR RESTS ON BLOCKING.
8. PLACE SECOND SLING AROUND REAR END OF GENERATOR, AND HOIST GENERATOR OUT OF VEHICLE.

**CAUTION:** GENERATOR IS HEAVY- HANDLE CAREFULLY TO AVOID INJURY TO PERSONNEL OR DAMAGE TO EQUIPMENT.

INSTALLATION

REVERSE REMOVAL PROCEDURE. BEFORE INSTALLING BELTS, RAISE GENERATOR UNTIL OIL FILL PLUG IS LEVEL WITH PULLEY SHAFT AND CHECK OIL LEVEL IN ACCORDANCE WITH LO 9-2350-230-12. REFER TO FIGURE 9-109 FOR ADJUSTMENT OF BELT TENSIONER.

GENERATOR POLARITY

AFTER INSTALLING GENERATOR AND BEFORE CONNECTING GENERATOR-TO-VOLTAGE REGULATOR HARNESS, CONNECT NEGATIVE TERMINAL OF BATTERY (12 OR 24V.) TO TERMINAL E (GROUND) ON GENERATOR, AND POSITIVE BATTERY TERMINAL MOMENTARILY TO TERMINAL A (SHUNT FIELD). THIS WILL INSURE PROPER GENERATOR POLARITY.

BRACKET REMOVAL/INSTALLATION

REMOVE 5 SCREWS, WASHERS AND GENERATING MOUNTING BRACKET. TIGHTEN SCREWS TO 16-20 POUND-FEET AT INSTALLATION.

WE 665561

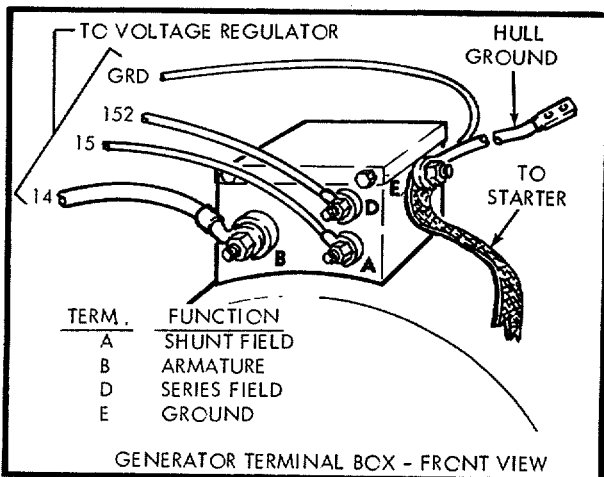
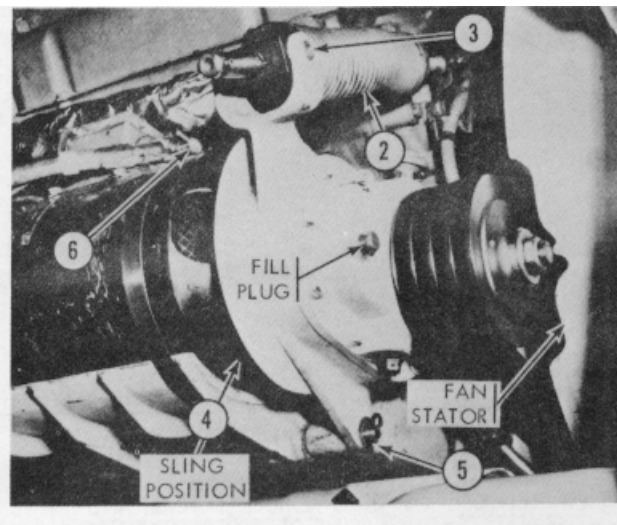
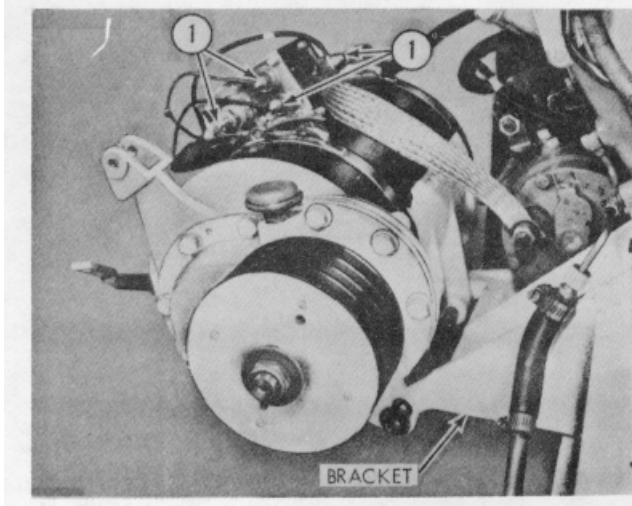
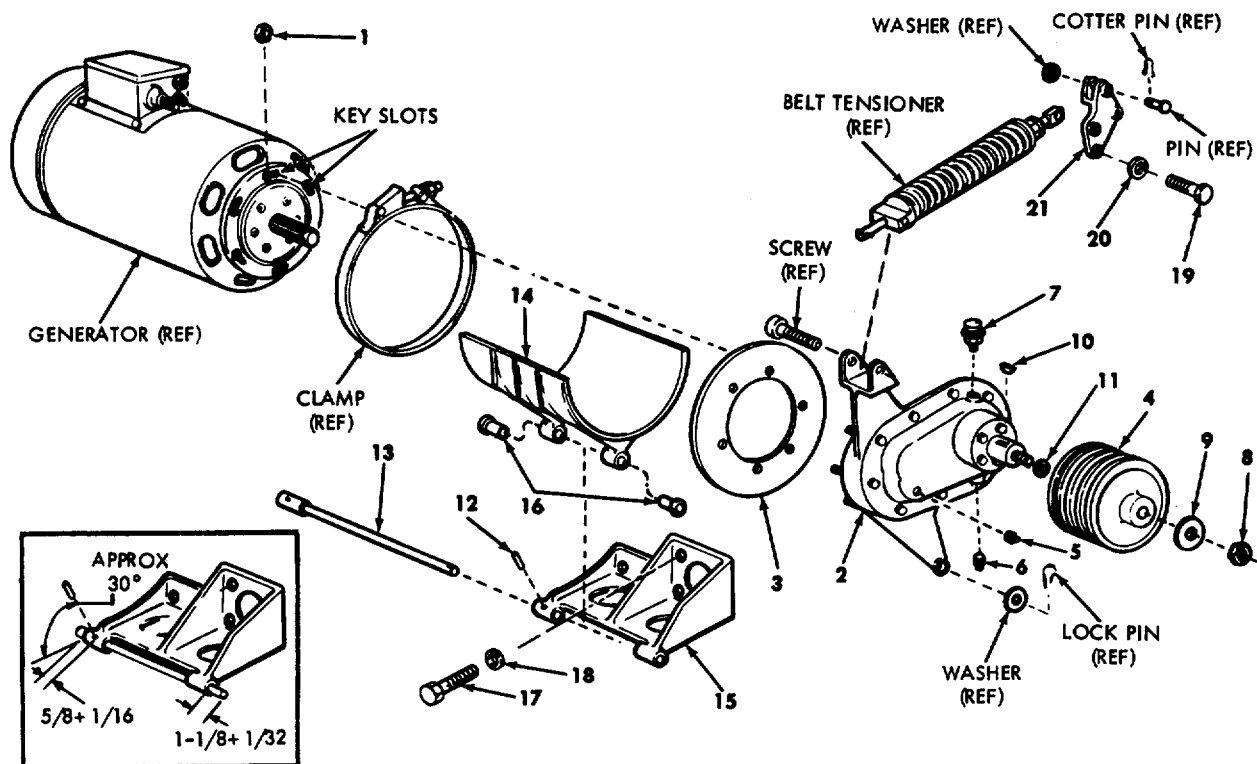

Figure 9-111. Removal/installation - generator and drive assembly

**LEGEND**

- |               |               |                |                 |
|---------------|---------------|----------------|-----------------|
| 1. NUT (6)    | 6. DRAIN PLUG | 11. WASHER     | 16. BUSHING (2) |
| 2. DRIVE ASSY | 7. BREATHER   | 12. SPRING PIN | 17. SCREW (5)   |
| 3. BAFFLE     | 8. NUT        | 13. MOUNT PIN  | 18. WASHER (5)  |
| 4. PULLEY     | 9. WASHER     | 14. CRADLE     | 19. SCREW (3)   |
| 5. FILL PLUG  | 10. KEY       | 15. BRACKET    | 20. WASHER (3)  |
|               |               |                | 21. BRACKET     |

**REMOVAL/INSTALLATION - GENERATOR DRIVE SYSTEM**

1. REMOVE GENERATOR AND DRIVE ASSEMBLY (FIG. 9-111).
2. LOOSEN NUTS (1), ROTATE DRIVE ASSEMBLY COUNTER-CLOCKWISE, AND REMOVE COMBINED DRIVE ASSEMBLY (2), BAFFLE (3) AND PULLEY (4) FROM KEY SLOTS IN GENERATOR BAFFLE.
3. REMOVE NUTS (1) TO REMOVE BAFFLE FROM DRIVE ASSEMBLY.

INSTALL BY REVERSING REMOVAL PROCEDURE. AFTER INSTALLATION, FILL DRIVE ASSEMBLY WITH ENGINE OIL TO LEVEL OF FILL PLUG OPENING (5) (LO 9-2350-230-12). CLEAN BREATHER (7) WITH TPM OR SD AND DRY WITH COMPRESSED AIR.

**REMOVAL/INSTALLATION - GENERATOR PULLEY**

1. REMOVE NUT (8) AND WASHER (9).
2. USE PULLER 5120-313-9496 TO REMOVE PULLEY (4). USE CAUTION TO AVOID LOSING KEY (10) AND WASHER (11).

INSTALL PULLEY BY TAPPING WITH SOFT HAMMER, AND TIGHTEN NUT (8) TO 90-110 POUND-FEET.

**CAUTION:** MAKE SURE KEY IS PROPERLY IN PLACE WHEN INSTALLING PULLEY.

**REMOVAL/INSTALLATION - GENERATOR CRADLE ASSEMBLY**

1. REMOVE GENERATOR W/DRIVE ASSEMBLY (FIG. 9-111).
2. REMOVE SPRING PIN (12)

**NOTE.** EARLY VEHICLES MAY NOT HAVE PROVISION FOR THIS PIN. ON THESE VEHICLES, BRACKET AND GENERATOR MOUNT PIN SHOULD BE DRILLED (.187 DIA., APPROX. 30° TO BASE OF BRACKET - SEE INSET) AND PIN MS16562-51 INSERTED AT INSTALLATION.

3. REMOVE GENERATOR MOUNT PIN (13) TO REMOVE CRADLE (14) FROM BRACKET (15). REPLACE BUSHINGS (16) AS REQUIRED.

INSTALL CRADLE BY REVERSING REMOVAL PROCEDURE.

**REMOVAL/INSTALLATION - GENERATOR BRACKET W/CRADLE**

1. REMOVE GENERATOR W/DRIVE ASSEMBLY (FIG. 9-111).
2. REMOVE SCREWS (17) AND WASHERS (18).
3. REMOVE BRACKET (15) W/CRADLE.

REPLACE UNSERVICEABLE COMPONENTS AS REQUIRED. INSTALL BY REVERSING REMOVAL PROCEDURE.

**REMOVAL/INSTALLATION - V-BELT TENSIONER BRACKET**

1. REMOVE V-BELT TENSIONER ASSEMBLY (FIG. 9-109).
2. REMOVE SCREWS (19) WASHERS (20) AND BRACKET (21).

INSTALL BRACKET AND TENSIONER BY REVERSING REMOVAL PROCEDURE. TIGHTEN TO 32-38 POUND-FEET. WE 66616

Figure 9-112. Removal/installation - generator drive, pulley, cradle, bracket, and V-belt tensioner bracket



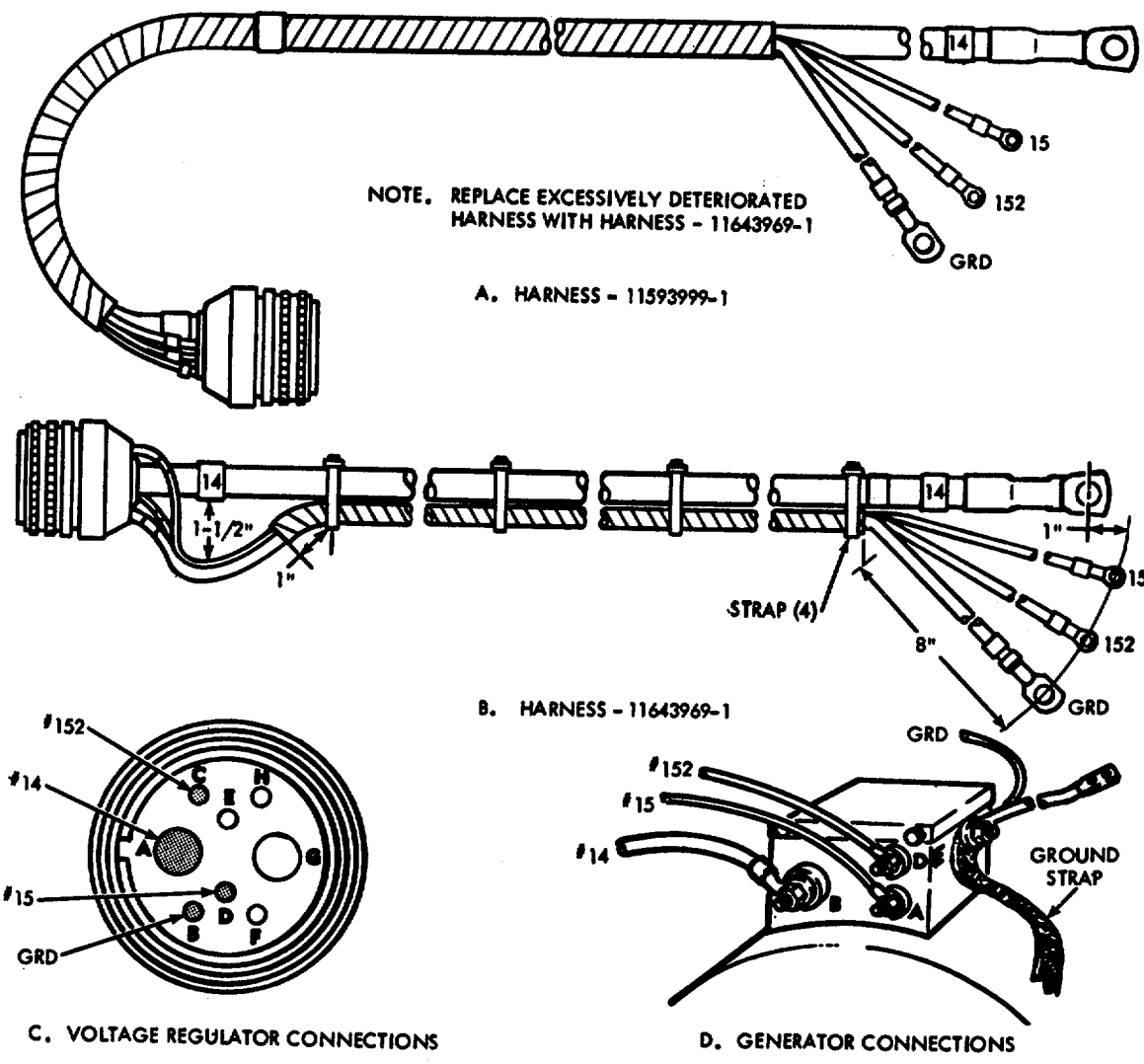

NOTE. REPLACE EXCESSIVELY DETERIORATED HARNESS WITH HARNESS - 11643969-1

A. HARNESS - 11593999-1

B. HARNESS - 11643969-1

C. VOLTAGE REGULATOR CONNECTIONS

D. GENERATOR CONNECTIONS

1. REMOVE HARNESS FROM GENERATOR AND VOLTAGE REGULATOR.
2. REMOVE WRAPPING AND STRAIGHTEN HARNESS.
3. VISUALLY CHECK EACH WIRE FOR KINKS AND FOR BREAKS IN INSULATION. REPLACE KINKED OR DAMAGED WIRES.  
 CIRCUIT #14 ..... M13486/1-14 (1/0 GAGE)  
 CIRCUITS #15 AND 152.. M13486/1-5 (14 GAGE)  
 GROUND CIRCUIT ..... M13486/1-7 (12 GAGE)  
 IDENTIFY NEW WIRES BY BAND (MS39020-1) ON EACH END, STAMPED WITH APPROPRIATE CIRCUIT NUMBERS.
4. TEST EACH WIRE FOR CONTINUITY, FLEXING THE WIRE WHILE CHECKING. REPLACE WIRES AS INDICATED BY TEST.
5. SOLDER NEW WIRES TO CONNECTOR PINS AS SHOWN IN VIEW "C."
6. TAPE CIRCUITS 15, 152 AND GRD TOGETHER, AS SHOWN IN VIEW "B" ABOVE.
7. INSTALL FOUR STRAPS (MS17821) AS SHOWN IN VIEW "B," LEAVING SLACK AT THE CONNECTOR AS SHOWN ON THE DRAWING.
8. CUT LEAD #14 AND SLIDE 1-3/4 INCHES OF HEAT-SHRINKABLE INSULATION (MIL-1-23053, CLASS 2 OR 3) ON THE LEAD. SOLDER NEW TERMINAL MS20659-18 ON THE LEAD SO THAT LEAD #14 WILL BE 1 INCH SHORTER THAN THE OTHER THREE LEADS, MEASURED TO THE CENTER LINE OF THE TERMINAL BINDING POST HOLES. APPLY HEAT TO INSULATION.
9. INSTALL HARNESS ("C" AND "D" ABOVE). BEND HARNESS AS NECESSARY TO FOLLOW ROUTING OF OLD HARNESS.

TA007334

Figure 9-112.1. Removal/installation/repair - generator-to-voltage regulator wiring harness.

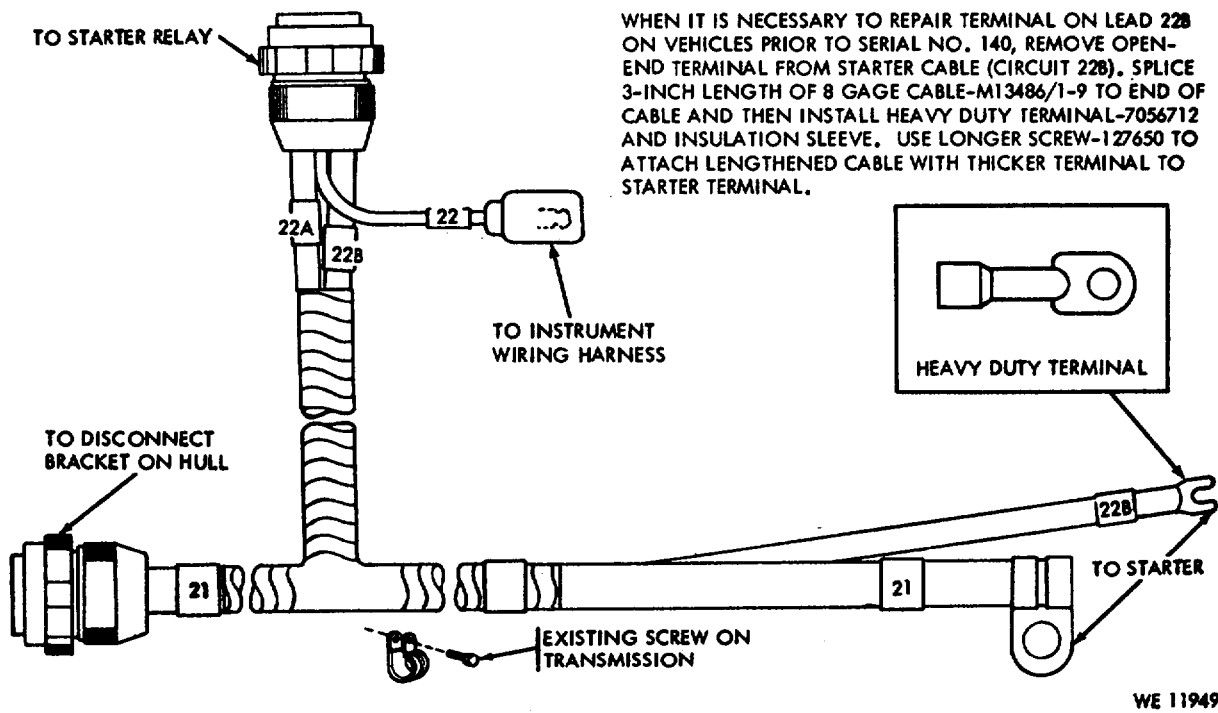
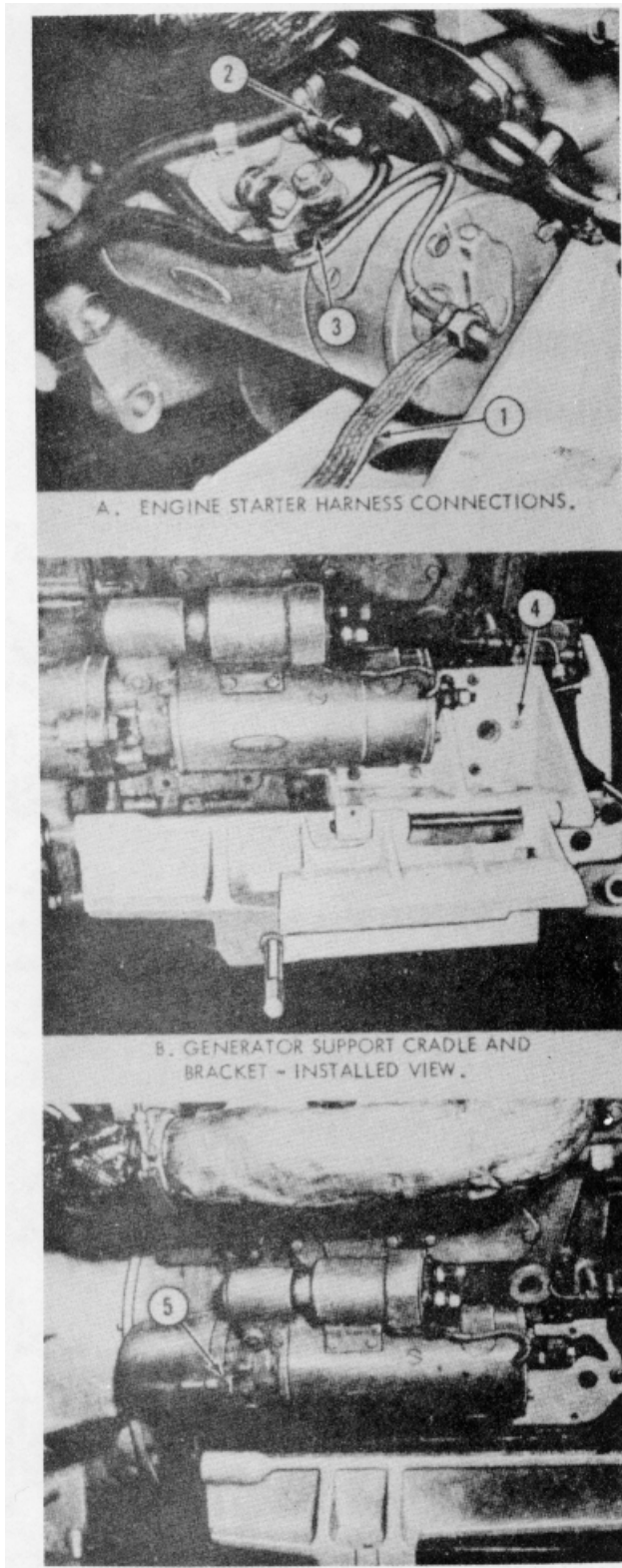

Figure 9-112.2. (Added) Repair - starter/starter relay wiring harness

9-118.2

PRELIMINARY STEPS

1. REMOVE POWER PLANT (FIGURES 9-3 THROUGH 9-6).
2. REMOVE GENERATOR (FIGURE 9-111).

REMOVAL

1. REMOVE NUT AND FLAT WASHER AND DISCONNECT GROUND STRAP AT STARTER.
2. REMOVE NUT AND FLAT WASHER AND DISCONNECT STARTER CABLE.
3. REMOVE SCREW AND DISCONNECT SOLENOID LEAD.
4. REMOVE 5 SCREWS, LOCK WASHERS, AND FLAT WASHERS AND REMOVE GENERATOR SUPPORT CRADLE AND GENERATOR SUPPORT BRACKET AS A COMBINED UNIT.
5. REMOVE BOLT, 2 SCREWS AND LOCK WASHERS AND PULL STARTER STRAIGHT OUT FROM ENGINE HOUSING.

**CAUTION:** STARTER WEIGHS APPROXIMATELY 80 POUNDS, USE CARE DURING REMOVAL AND INSTALLATION

INSTALLATION

REVERSE REMOVAL PROCEDURE TO INSTALL ENGINE STARTER.

WE 11112AI

Figure 9-113. (Superseded) Removal/installation - engine starter

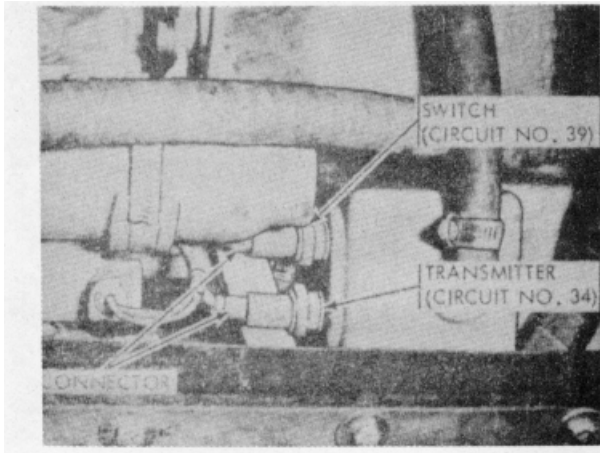

A. ENGINE COOLANT HIGH TEMPERATURE SWITCH AN,J  
ENGINE COOLANT TRANSMITTER.

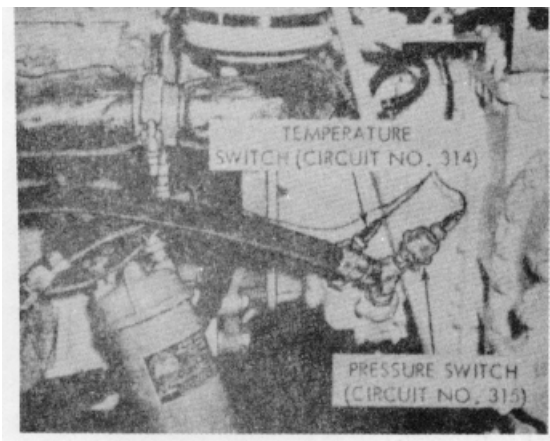

B. TRANSMISSION OIL HIGH TEMPERATURE SWITCH AND LOW  
PRESSURE SWITCH. REMOVAL - ENGINE OIL PRESSURE  
SWITCH

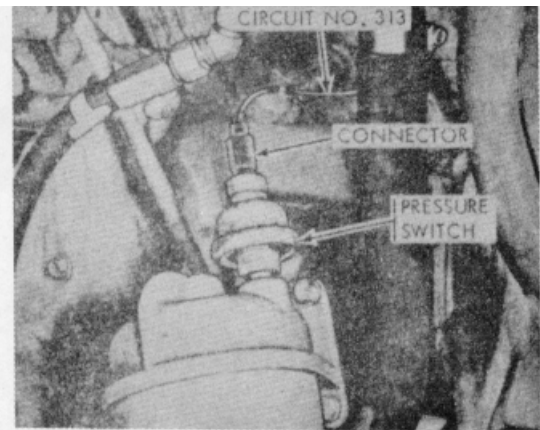

C. ENGINE OIL LOW PRESSURE SWITCH.

REMOVAL- ENGINE COOLANT HIGH TEMPERATURE SWITCH  
AND TEMPERATURE TRANSMITTER

PRELIMINARY STEPS

- A. REMOVE AIR INLET GRILLE, GRILLE SUPPORT, AND ENGINE ACCESS COVER (STEPS I THROUGH 5, FIG. 9-3).
- B. REMOVE CAP FROM TOP OF COOLANT SURGE TANK AND DRAIN COOLANT BELOW LEVEL OF SWITCH OR TRANSMITTER. USE SUITABLE CONTAINER. PETCOCK IS LOCATED ON BOTTOM OF THERMOSTAT HOUSING (FIG. 9-2).

REMOVAL- TRANSMISSION TEMPERATURE AND PRESSURE  
SWITCHES

PRELIMINARY STEPS

- A. OPEN LEFT ENGINE GRILLE.
- B. REMOVE AIR CLEANER DUCT AND COVER OPENINGS IN AIR CLEANER AND TURBOCHARGER (STEP I, FIG. 9-4).

REMOVAL

- 1. DISCONNECT ELECTRICAL LEAD TO UNSERVICEABLE ITEM.
- 2. UNSCREW UNSERVICEABLE SWITCH.

INSTALLATION

REVERSE REMOVAL PROCEDURE

PRELIMINARY STEPS

- A. OPEN LEFT ENGINE GRILLE.
- B. REMOVE AIR CLEANER DUCT AND COVER OPENINGS IN AIR CLEANER AND TURBOCHARGER (STEP I, FIG. 9-4).

REMOVAL

- 1. DISCONNECT ELECTRICAL LEAD.
- 2. UNSCREW SWITCH.

INSTALLATION

REVERSE REMOVAL PROCEDURE.

WE 11095

Figure 9-114. Removal/installation - power plant temperature and pressure switches and transmitters

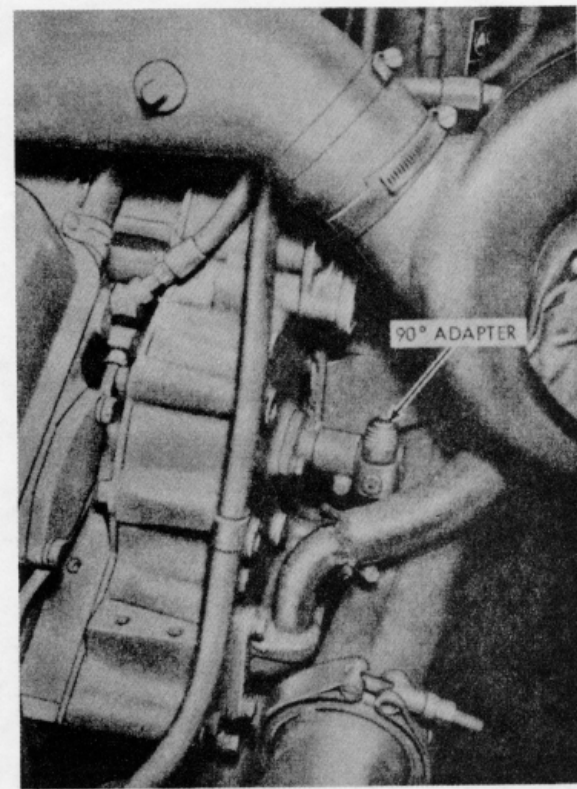

A. TACHOMETER GENERATOR RIGHT ANGLE DRIVE ADAPTER (ENGINES PRIOR TO SN 6D 42352) INSTALLATION SURGE TANK AND BRACKET REMOVED FOR CLARITY

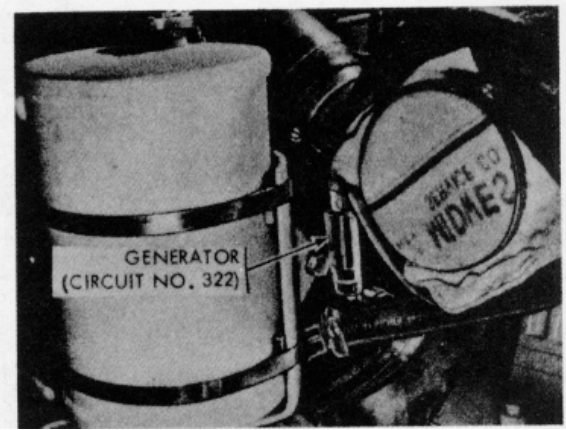

B. TACHOMETER GENERATOR INSTALLED ON ADAPTER.

#### REMOVAL- TACHOMETER GENERATOR

1. OPEN LEFT ENGINE GRILLE.
2. REMOVE AIR CLEANER DUCT, COVER OPENINGS IN AIR CLEANER DUCT. CLEANER AND TURBOCHARGER (STEP 1, DIG. 9-4).
3. DISCONNECT ELECTRICAL LEAD.
4. ENGINES PRIOR TO SN 6D 42352: UNSCREW GENERATOR. USE CARE DURING REMOVAL AND INSTALLATION TO AVOID LOSING KEY (FIG. 9-116, ITEM 13).
- 4A. EFFECTIVE ENGINE SN 6D 42352: REMOVE 2 BOLTS AND WASHERS (FIG. 9-116, ITEMS 17 AND 18) AND REMOVE TACHOMETER GENERATOR

#### INSTALLATION

REVERSE REMOVAL PROCEDURE.

#### REMOVAL - SPEEDOMETER GENERATOR AND ODOMETER ADAPTER.

##### PRELIMINARY STEPS

- A. OPEN BOTH ENGINE GRILLES.
- B. REMOVE 2 REAR SCREWS ATTACHING GRILLE SUPPORT TO ENGINE ACCESS COVER.
- C. REMOVE ENGINE ACCESS COVER (STEPS 3, 4, AND 5, FIG. 9-3).

##### REMOVAL

1. DISCONNECT ODOMETER AND SPEEDOMETER ELECTRICAL LEADS.
2. UNSCREW GENERATOR. USE CARE DURING REMOVAL OR INSTALLATION TO PREVENT LOSS OF KEY (ITEM 13, FIG. 9-116).
3. DISCONNECT SPEEDOMETER CABLE
4. REMOVE 2 NUTS, WASHERS, SCREWS, AND ODOMETER ADAPTER.

##### INSTALLATION

REVERSE REMOVAL PROCEDURE.

**INSTALLATION NOTE.** TWO EXTERNAL-TOOTHED LOCKWASHERS MUST BE INSTALLED BETWEEN ODOMETER ADAPTER AND HULL BRACKET TO PROVIDE PROPER GROUND. TIGHTEN SCREWS TO 25-31 POUND-FEET.

WE 12185 |

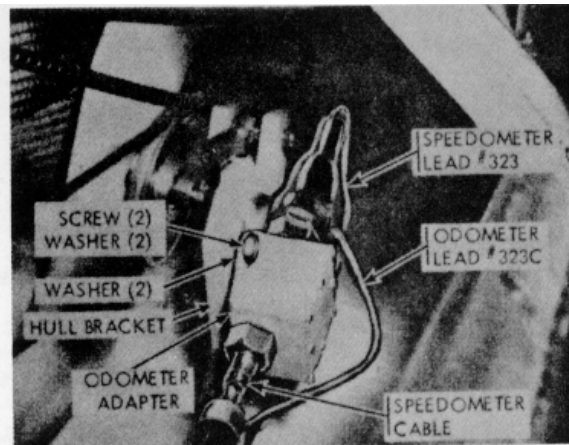

C. SPEEDOMETER GENERATOR AND ODOMETER ADAPTER ASSEMBLY

Figure 9-115. Removal/installation - speedometer and tachometer generators, and odometer adapter

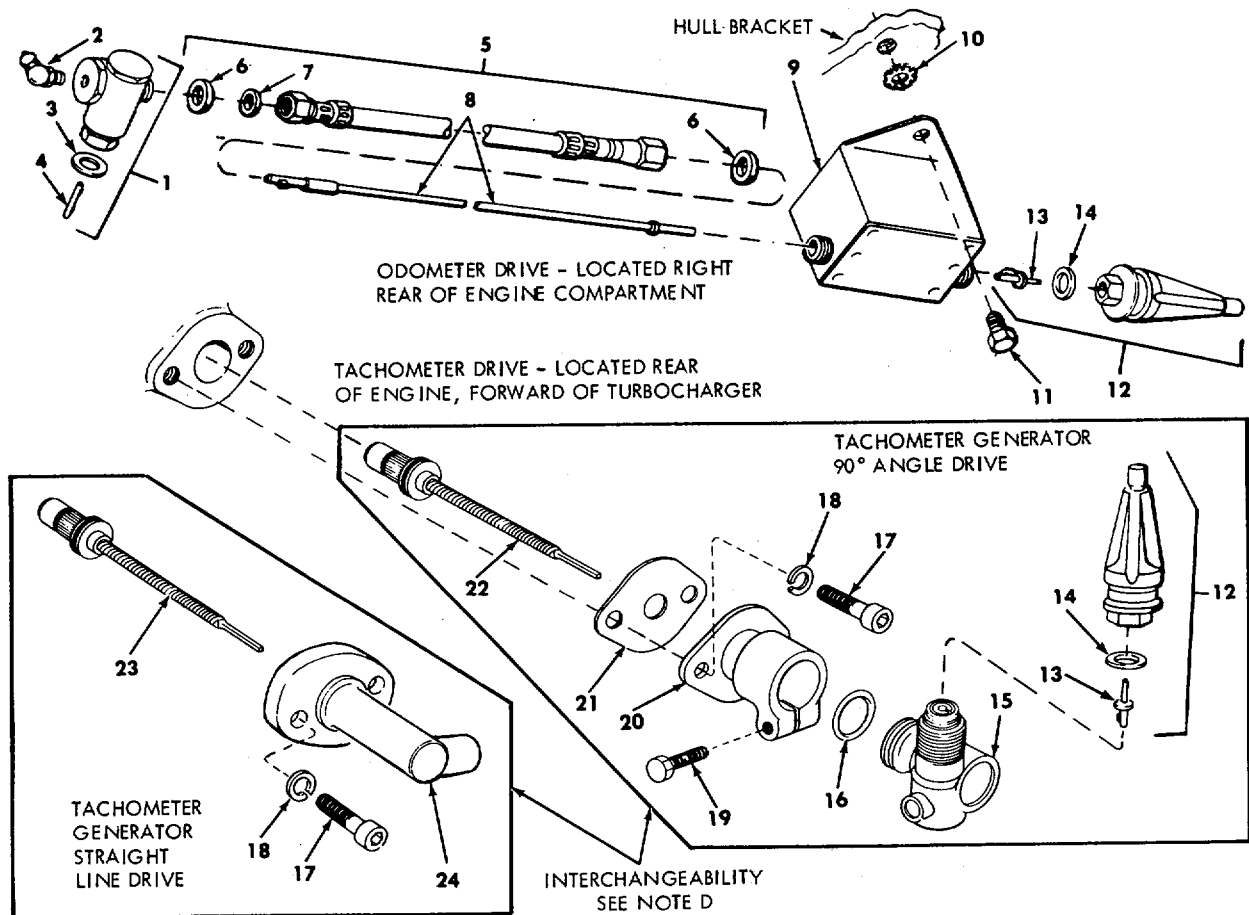

- |                         |                        |                     |                          |
|-------------------------|------------------------|---------------------|--------------------------|
| 1. ADAPTER ASSY         | 7. WASHER              | 13. KEY (2)         | 19. SCREW                |
| 2. GREASE FITTING       | 8. CABLE ASSY          | 14. WASHER          | 20. ADAPTER              |
| 3. WASHER - NONMETALLIC | 9. ODOMETER ADAPTER    | 15. 90° ADAPTER     | 21. GASKET               |
| 4. KEY                  | 10. LOCK WASHER (2)    | 16. PACKING         | 22. FLEXIBLE DRIVE SHAFT |
| 5. FLEXIBLE SHAFT ASSY  | 11. SCREW (2)          | 17. BOLT (2)        | 23. FLEXIBLE DRIVE SHAFT |
| 6. WASHER - NONMETALLIC | 12. GENERATOR ASSY (2) | 18. LOCK WASHER (2) | 24. TACHOMETER GENERATOR |

PRELIMINARY STEPS

- A. OPEN EXHAUST GRILLES AND REMOVE THE TWO REAR GRILLE SUPPORT SCREWS (STEP 2, FIG. 9-3).
- B. FOLLOW STEPS 3 THROUGH 5, FIGURE 9-3, TO REMOVE ENGINE ACCESS COVER.  
USE CARE DURING REMOVAL AND INSTALLATION TO AVOID DROPPING OR LOSING KEYS (4 AND 13).

REMOVAL/INSTALLATION - REPLACE UNSERVICEABLE ITEMS AS REQUIRED.

INSTALLATION NOTES:

- A. REMOVE FINISH UNDER BOLT HEADS (17) TO INSURE PROPER GROUNDING OF ADAPTER (20) OR GENERATOR (24)
- B. EXTERNAL TOOTHED LOCK WASHERS MUST BE INSTALLED BETWEEN ODOMETER ADAPTER (9) AND HULL BRACKET.
- C. ITEMS 22 AND 23 ARE PRESS-FIT INTO RECESS AT REAR END OF CAM SHAFT.
- D. (1). IF ENGINE PRIOR TO SN 6D 42352 IS REPLACEMENT FOR LATER DESIGN ENGINE, REQUISITION GENERATOR PN 10918249-1, FSN 6680-916-2158. INSTALL GENERATOR ON RIGHT ANGLE ADAPTER ON ENGINE AND CONNECT TACHOMETER HARNESS LEAD.  
(2). IF ENGINE PRIOR TO SN 6D 42352 IS REPLACED BY LATER DESIGN ENGINE, CONNECT TACHOMETER HARNESS TO TACHOMETER GENERATOR ON NEW ENGINE. RETURN GENERATOR (PN 10918249-1) FROM OLD ENGINE TO FIELD SERVICE STOCK.

WE 12135

Figure 9-116. Removal/installation - odometer, speedometer and tachometer generator drives

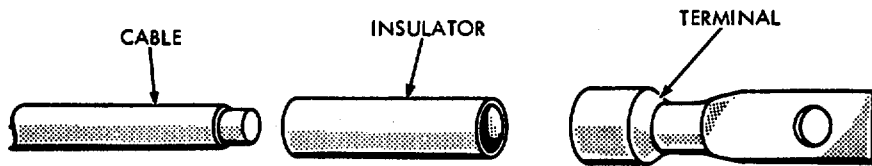

- 1 - SLIDE INSULATOR OVER CABLE.
- 2 - STRIP CABLE INSULATION EQUAL TO DEPTH OF TERMINAL WELL.
- 3 - INSERT CABLE INTO TERMINAL WELL AND CRIMP OR SOLDER.
- 4 - SLIDE INSULATOR OVER CRIMPED END OF TERMINAL.

**A - TERMINAL-TYPE CABLE CONNECTORS**

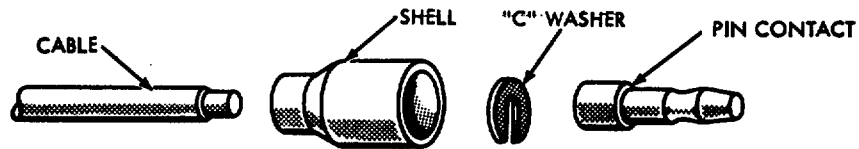

- 1 - SLIDE SHELL OVER CABLE.
- 2 - STRIP CABLE INSULATION EQUAL TO DEPTH OF PIN CONTACT WELL.
- 3 - INSERT CABLE INTO PIN CONTACT WELL AND CRIMP OR SOLDER.
- 4 - PLACE "C" WASHER OVER CABLE AT CRIMPED JUNCTION AND SLIDE SHELL OVER "C" WASHER AND TERMINAL.

**B - FEMALE CABLE CONNECTOR (12,14, AND 16 GAGE CABLE)**

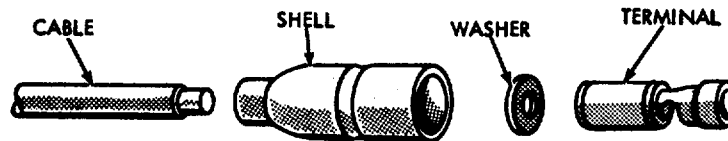

- 1 - SLIDE SHELL OVER CABLE AND INSTALL WASHER.
- 2 - STRIP CABLE INSULATION APPROXIMATELY 1/4 INCH.
- 3 - PLACE CABLE IN CYLINDRICAL END OF TERMINAL AND CRIMP OR SOLDER.
- 4 - SLIDE SHELL AND WASHER OVER TERMINAL.

**C - MALE CABLE CONNECTOR (12 GAGE CABLE)**

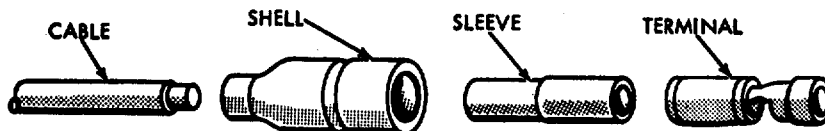

- 1 - SLIDE SHELL AND SLEEVE OVER CABLE.
- 2 - STRIP CABLE INSULATION APPROXIMATELY 1/4 INCH.
- 3 - PLACE CABLE IN CYLINDRICAL END OF TERMINAL AND CRIMP OR SOLDER.
- 4 - SLIDE SHELL AND SLEEVE OVER TERMINAL.

**D - MALE CABLE CONNECTOR (16-14 GAGE CABLE)**

WE 11097

Figure 9-117. Replacing cable terminals and connectors.

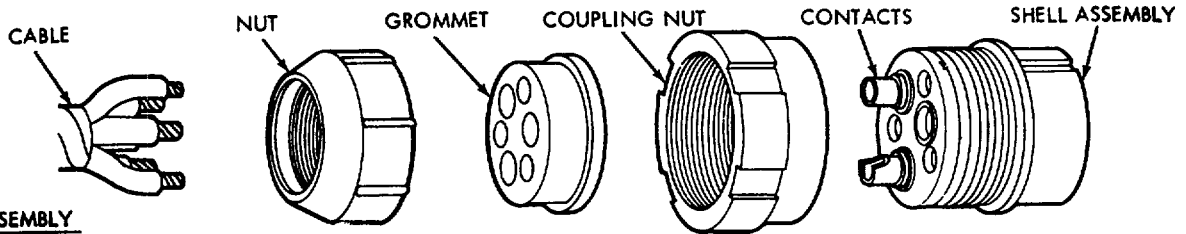

**DISASSEMBLY**

1. UNSCREW NUT FROM SHELL ASSEMBLY AND SLIDE BACK ON CABLE.
2. PUSH GROMMET BACK ON CABLE LEADS.
3. UNSOLDER LEADS FROM SOCKET CONTACTS.
4. SLIDE COUPLING NUT OFF SHELL.

3. STRIP CABLE INSULATION EQUAL TO DEPTH OF SOLDER WELLS OF CONTACTS.
4. SLIDE COUPLING NUT ONTO SHELL ASSEMBLY.
5. INSERT CABLE LEADS INTO SOLDER WELLS OF CONTACTS AND SOLDER.
6. PUSH GROMMET DOWN CABLE LEADS AND OVER SOLDER WELLS OF CONTACTS.
7. SCREW NUT ONTO SHELL ASSEMBLY.
8. PLUG UNUSED GROMMET HOLES.

**ASSEMBLY**

1. SLIDE NUT OVER CABLE LEADS.
2. MOISTEN GROMMET WITH ALCOHOL AND SLIDE OVER CABLE LEADS.

**DISASSEMBLY/ASSEMBLY OF TYPICAL MALE AND FEMALE PLUG**

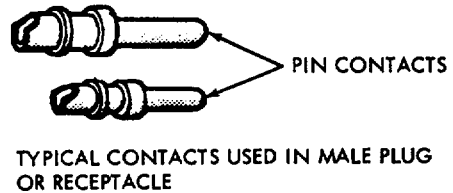
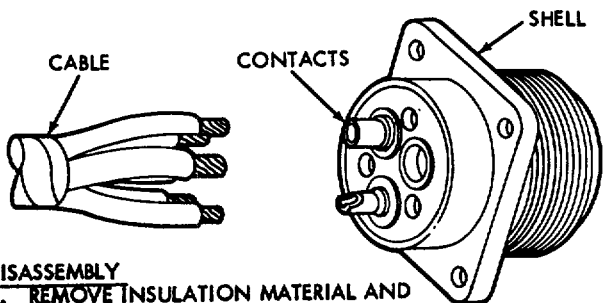

TYPICAL CONTACTS USED IN MALE PLUG OR RECEPTACLE

**DISASSEMBLY**

1. REMOVE INSULATION MATERIAL AND UNSOLDER CABLE LEADS FROM SOLDER WELLS ON CONTACTS.

**ASSEMBLY**

1. SLIDE INSULATION MATERIAL OVER CABLE LEADS.
2. STRIP CABLE INSULATION EQUAL TO DEPTH OF SOLDER WELLS OF CONTACTS.
3. INSERT CABLE LEADS INTO SOLDER WELLS OF CONTACTS AND SOLDER.
4. SLIDE INSULATION MATERIAL OVER CONTACTS.

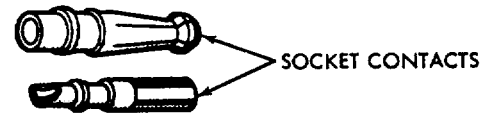

TYPICAL CONTACTS USED IN FEMALE PLUG OR RECEPTACLE

**DISASSEMBLY/ASSEMBLY OF TYPICAL MALE AND FEMALE PANEL MOUNTING RECEPTACLE**

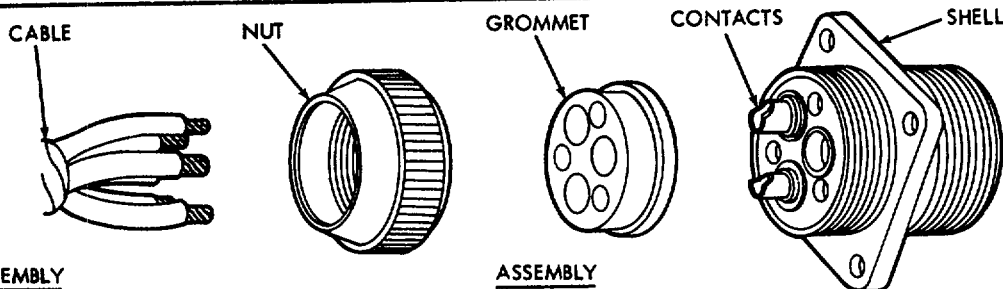

**DISASSEMBLY**

1. UNSCREW NUT FROM SHELL ASSEMBLY AND SLIDE BACK ON CABLE.
2. PUSH GROMMET BACK ON CABLE LEADS.
3. UNSOLDER LEADS FROM SOCKET CONTACTS.

**ASSEMBLY**

1. SLIDE NUT OVER CABLE.
2. SLIDE GROMMET OVER CABLE LEADS.
3. STRIP CABLE INSULATION TO DEPTH OF SOLDER WELLS OF CONTACTS.
4. INSERT CABLE LEADS INTO SOLDER WELLS OF CONTACTS AND SOLDER.
5. PUSH GROMMET DOWN CABLE LEADS AND OVER SOLDER WELLS OF CONTACTS.
6. SCREW NUT ONTO SHELL ASSEMBLY.

**DISASSEMBLY/ASSEMBLY OF TYPICAL MALE AND FEMALE RECEPTABLES**

WE 11098

Figure 9-118. Replacing typical electrical plug and receptacle connectors



**Section 9-6. HULL AND COMPONENTS**

**9-14. General**

This section contains organizational maintenance instructions for the vehicle hull and components listed in table 9-13. Refer to

figure 9-148 for repair of flotation skin and paragraph 9-15 for repair of barrier.

TABLE 9-13. HULL AND COMPONENTS

ASSEMBLY OR COMPONENT	FIGURE REFERENCE		
	ADJUST	REPLACE	REPAIR
Surfboard and Controls (Veh. Ser. 1-69)	9-119		9-119. 1
Surfboard and Controls (Eff. Veh. Ser. 70)	9-119. 2		9-119. 3, 119. 4
Driver's Rotatable Hatch. Components		9-120, 121	
Driver's Escape Hatch Components		9-122	
Driver's Seat		9-123	9-124, 125
Ammunition Racks			9-126, 127, 128
Bilge Pumps (Rear)		9-129	9-129
Bilge Pump (Front)		9-130,131.1	9-130, 131,131.2
Personnel Heater		9-132	9-133 through 9-137
Crew Compartment Fire Extinguisher	9-138, 138.1	9-139, 139.2	9-139, 139.3, 139.4
Fixed (Engine Compartment) Fire Extinguisher	9-138, 140	9-139, 141	9-139, 141
Radiator Contamination Shield and Grille.		9-142.1	
Debris Screens			9-145, 146, 146.1
Hull Interior Stowage			9-147
Hull Exterior Stowage			9-148
Flotation Skin			9-142. 2
Air Cleaner and Battery Access Cover		9-142. 2	

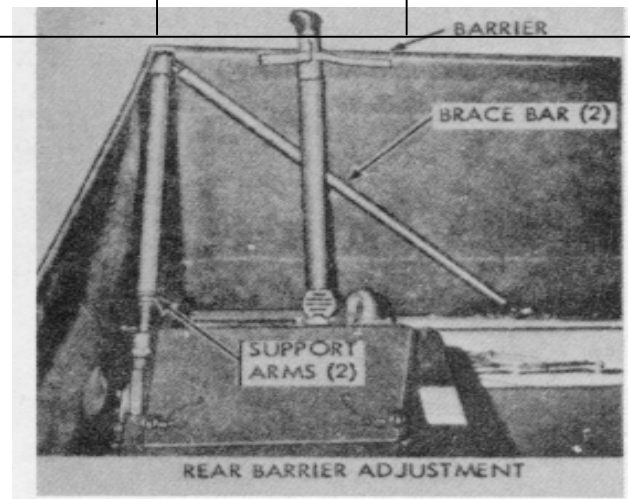
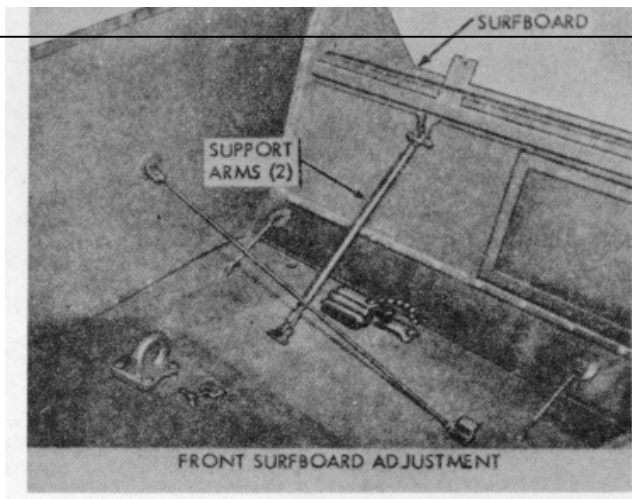

**ADJUSTMENT**

1. ADJUST TWO REAR BRACE BARS TO REMOVE WRINKLES FROM REAR BARRIER. DO NOT OVERTIGHTEN.
2. ADJUST FRONT AND REAR SUPPORT ARMS TO REMOVE WRINKLES FROM BARRIER SIDES. DO NOT OVERTIGHTEN AS PRODUCTION TOLERANCES MAY RESULT IN SOME WRINKLES.

TA0073351

Figure 9-119. Adjustment - surfboard and barrier supports (effective through vehicle serial no. 69)

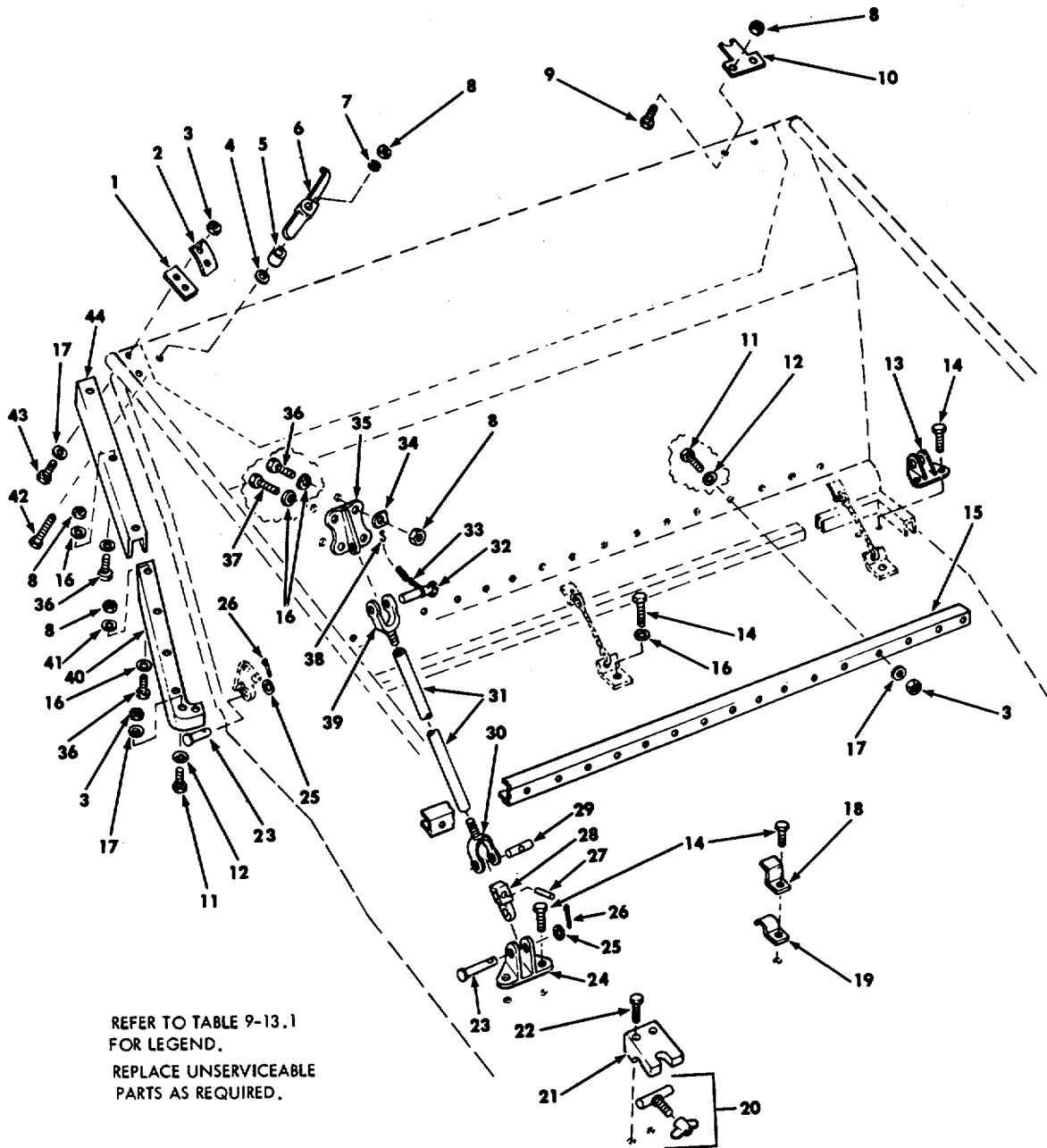

WE 11940

Figure 9-119.1. Disassembly/repair/assembly - surfboard and barriers (effective through vehicle serial no. 69)

TABLE 9-13.1. LEGEND FOR FIGURE 9-119.1

1. PAD - 10955301	24. BRACKET - 10955303
2. PLATE - 10955302	25. WASHER - MS27183-18
3. NUT - 8712289-2	26. COTTER PEN - MS24665-285
4. SHIM - 10955299-1, -2, -3	27. SPRING PIN - MB9048-015
5. SPACER - 10955298	28. SWIVEL JOINT - 10955292
6. LEVER - 10955297	29. PIN - 10955293
7. WASHER - 10941915-3	30. CLEVIS- 10955291-2
8. NUT - 8712289-3	31. SUPPORT - 10955290
9. SCREW - MS35191-322	32. PIN - N817990-C812
10. PLAT- 109,55275	33. CHAIN Type II CLASS 2 TRAD NO. 7, (6-INCHES LONG)
11. SCREW - M119077-39	34. LUG - 10955294
12. WASHER - 10955576-1	35. BRACKET -10955304
13. BRACKET - 10955300	36. SCREW - M90727-66
14. SCREW - MS90728-80	37. 8CREW - 1190727-65
15. BRACKET - 10955520	38. 8-HOOK - 1887006-23
16. WASHER - 10910174-3	39. CLEVIS - 10955291-1
17. WASHER - 10910174-2	40. LEFT BRACKET - 10955532-1
18. GUARD - 10956065	RIGHT BRACKET - 10955522-2 (NOT SHOWN)
19. CLIP - 10955295	41. WASHER - 10955576-2
20. HOLD-DOWN - 10953785	42. SCREW - M635191-325
21. RETAINER - 10953780	43. SCREW - 1190727-38
22. SCREW - MS90728-62	44. BRACKET - 10955518
23. PIN - MS20392-7C53	

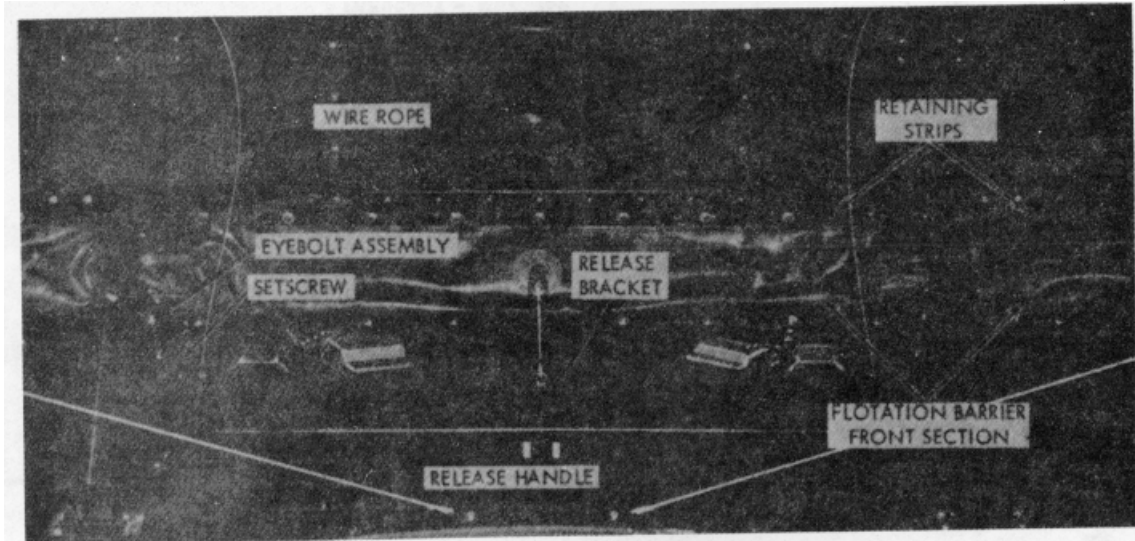

PRELIMINARY STEPS (REFER TO FIG. 9-119.3 AND 9-119.4)

- A. RELEASE LATCHES TO PERMIT SURFBOARD EXTENSION TO FOLD DOWN BEFORE REMOVING LATCH COMPONENTS.
- B. BLOCK SURFBOARD SECURELY IN UPRIGHT POSITION BEFORE REMOVING SUPPORT BRACKETS OR ASSOCIATED HARDWARE.
- C. ITEMS 99 THROUGH 116. REMOVE SCREWS AND RETAINING STRIPS AS NECESSARY TO FOLD BACK FRONT SECTION OF FLOTATION BARRIER TO GAIN ACCESS TO ITEMS 99 THROUGH 116. (SEE PHOTO ABOVE).

INSTALLATION NOTE CLEAN MOUNTING SURFACE ON SURFBOARD, AND APPLY SEALING TAPE FSN 8030-262-9019 ALONG BEAD OF FLOTATION BARRIER BETWEEN BARRIER AND SURFBOARD.

DISASSEMBLY/REPAIR/ASSEMBLY

REPLACE UNSERVICEABLE COMPONENTS AS REQUIRED.

ADJUSTMENT (REFER TO FIG. 9-119.3)

1. LOOSEN LOCKNUT (ITEM 34) AND ADJUST SETSCREW SO THAT EYEBOLT ASSEMBLY (ITEMS 27 THROUGH 32) IS <sup>90°</sup> TO HULL SURFACE. THEN BACK SETSCREW OUT TWO MORE TURNS, AND TIGHTEN LOCKNUT.
2. LOOSEN LOCKNUTS (ITEMS 28 AND 29) AND ADJUST LENGTH OF EYEBOLT ASSEMBLY BY TURNING BARREL UNTIL UNDER SURFACE OF UPPER SUPPORT (ITEM 22) JUST TOUCHES MACHINED SURFACE OF LOWER SUPPORT (ITEM 44). TIGHTEN LOCKNUTS.
3. SURFBOARD RELEASE BRACKET MAY BE ADJUSTED BY LOOSENING MOUNTING SCREWS (ITEM 54) AND REPOSITIONING BRACKET TO RETAIN RELEASE HANDLE (ITEM 38) IN LOCKED POSITION.
4. ADJUST SLACK IN WIRE ROPE (ITEM 6) BY MEANS OF LOCKNUTS (ITEM 5) AT THE LATCH, SO THAT UPPER SURFBOARD RELEASES SIMULTANEOUSLY WITH INITIAL RELEASE OF MAIN SURFBOARD. UPPER SURFBOARD MUST BE RELEASED BEFORE MAIN SURFBOARD STARTS TO FALL.

**TA0073361**

*Figure 9-119.2 Disassembly/repair/assembly - surfboard and barriers (effective vehicle serial no. 70) (1 of 3).*

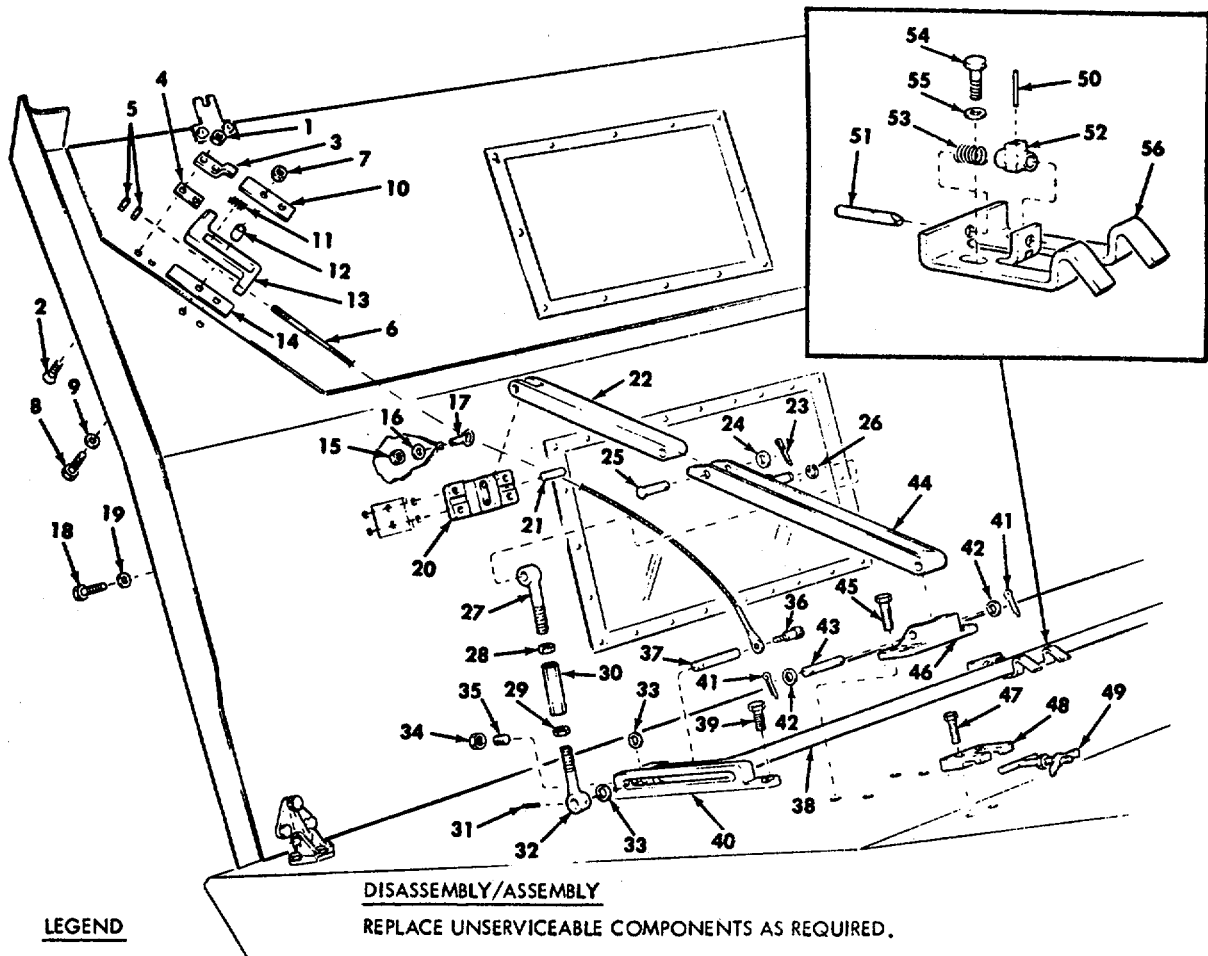
**LEGEND**

1. NUT (4)
2. SCREW (4)
3. CATCH (2)
4. SHIM (2)
5. NUT (4)
6. WIRE ROPE (2)
7. NUT (4)
8. SCREW (4)
9. FLAT WASHER (4)
10. LATCH COVER (2)
11. LATCH SPRING (2)
12. SPACER (4)
13. LATCH (2)
14. LATCH STRIP (2)
15. NUT (2)
16. FLAT WASHER (2)
17. EYE BOLT (2)
18. SCREW (8)
19. FLAT WASHER (8)
20. UPPER SUPPORT BRACKET (2)

**DISASSEMBLY/ASSEMBLY**

REPLACE UNSERVICABLE COMPONENTS AS REQUIRED.

21. PIN (2) (PRESS FIT) \*  
\*DO NOT REMOVE UNLESS PIN (21), BRACKET (20) OR UPPER SUPPORT (22) IS TO BE REPLACED.
22. UPPER SUPPORT (2)
23. COTTER PIN (2)
24. FLAT WASHER (2)
25. PIN (2)
26. SNAP RING (2)
27. EYE BOLT (2)
28. LOCK NUT (2)
29. LOCK NUT (2)
30. BARREL (2)
31. PIN (2)
32. EYE BOLT (2)
33. FLAT WASHER (4)
34. LOCK NUT (2)
35. SET SCREW (2)
36. SCREW (2)
37. PIN (2)
38. SURFBOARD RELEASE HANDLE
39. SCREW (4)
40. GUIDE (2)
41. COTTER PIN (4)
42. FLAT WASHER (4)
43. PIN (2)
44. LOWER SUPPORT (2, LEFT SHOWN)
45. SCREW (8)
46. LOWER SUPPORT BRACKET (2)
47. SCREW (4)
48. HOLD DOWN RETAINER (2)
49. HOLD DOWN ASSEMBLY (2)
50. PIN
51. SURFBOARD RELEASE PIN
52. TRIGGER
53. SPRING
54. SCREW (2)
55. FLAT WASHER (2)
56. SURFBOARD RELEASE BRACKET

(CONTINUED ON  
FIGURE 9-119.4)

WE 11914A

Figure 9-119.3 (Superseded) Disassembly/repair/assembly - surfboard and barriers (2 of 3) (effective with vehicle serial no. 70)

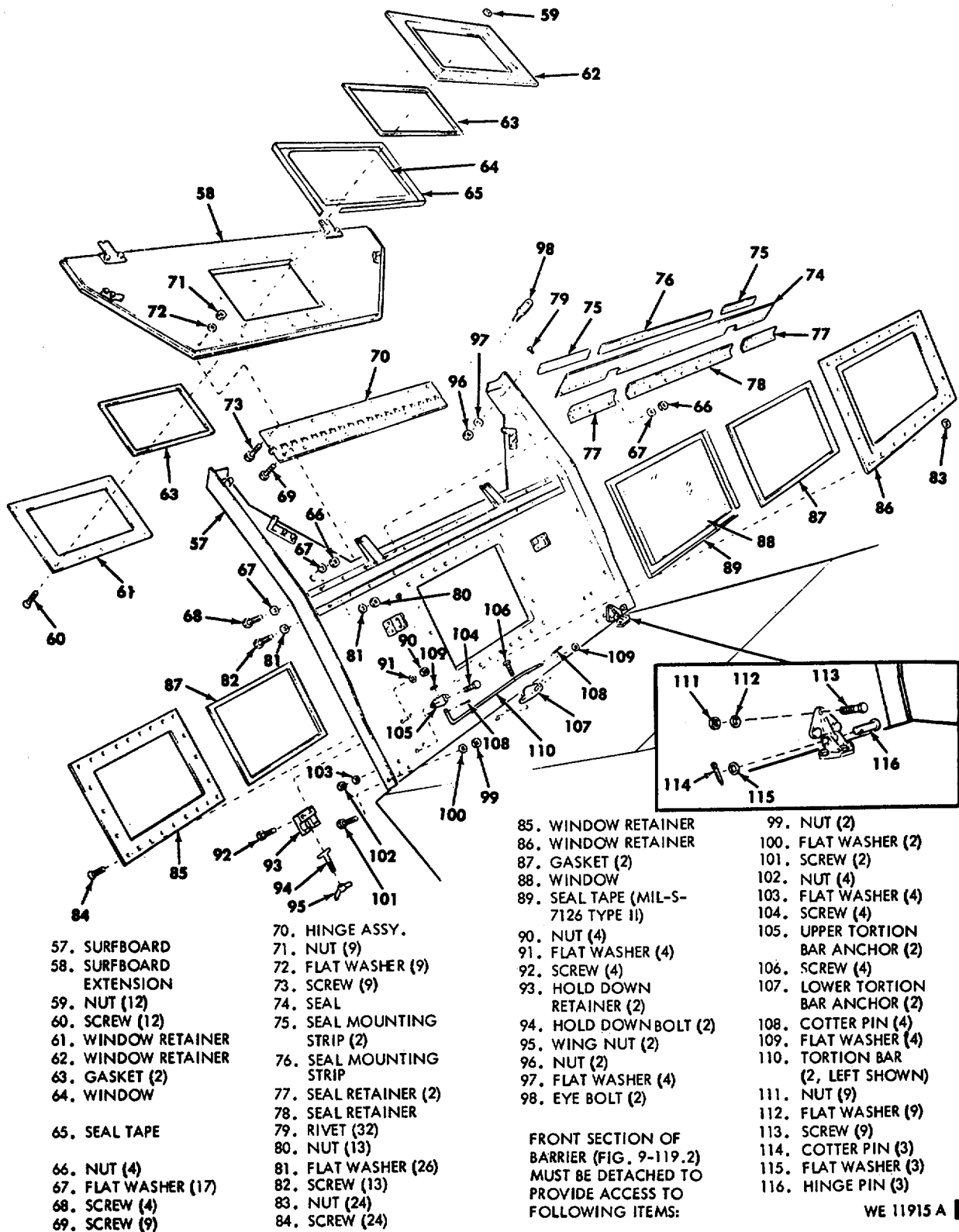

Figure 9-119.4 (Superseded) Disassembly/repair/assembly - surfboard and barriers (3 of 3) (effective vehicle serial no. 70)

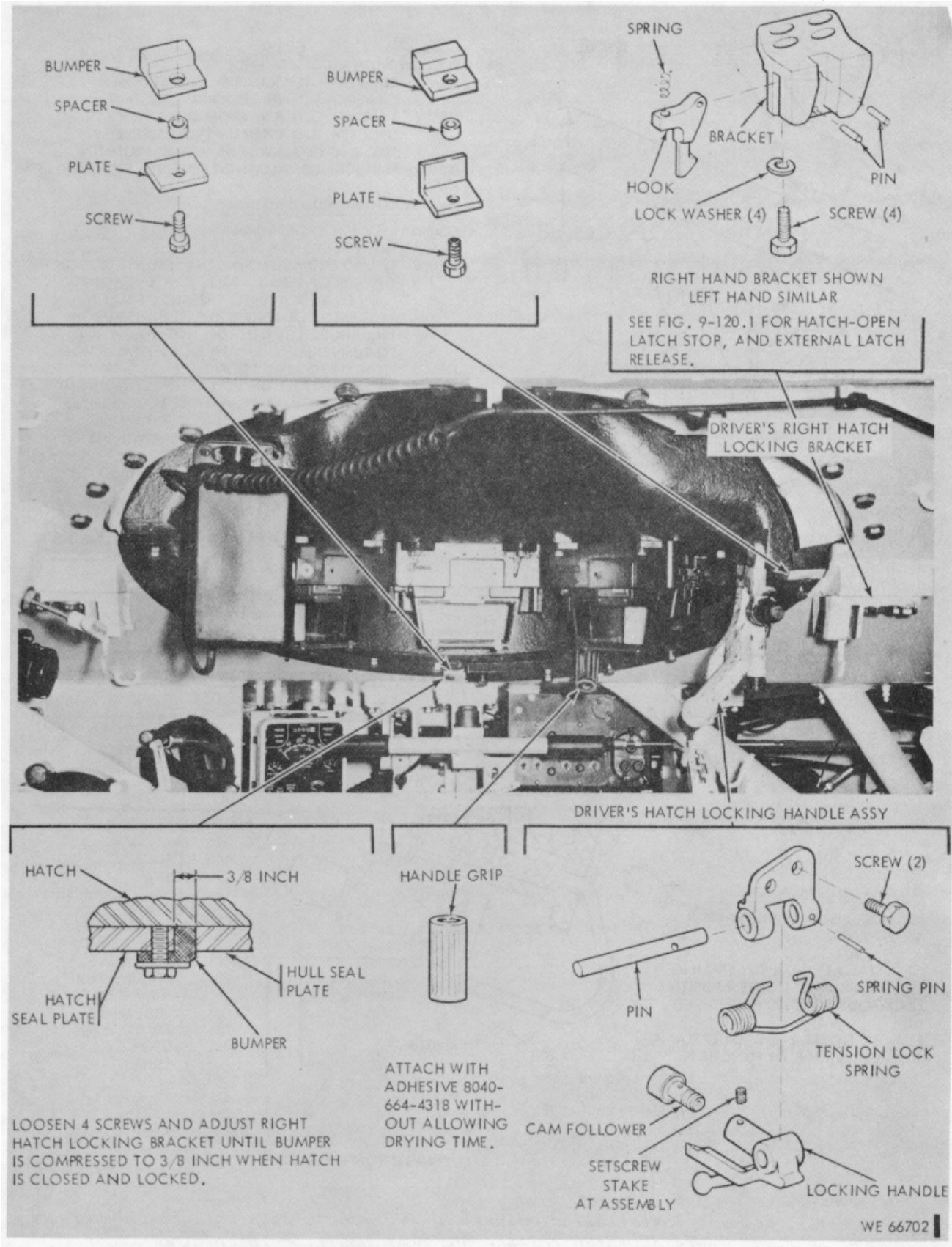
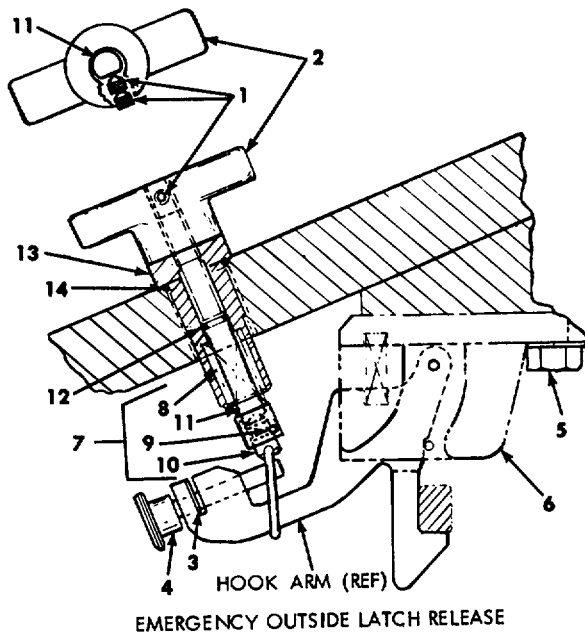

Figure 9-120. Removal/installation - driver's rotatable hatch locking latch, grip, and o bumpers



EMERGENCY OUTSIDE LATCH RELEASE

**LEGEND**

- |                          |                   |
|--------------------------|-------------------|
| 1. SETSCREW (2)          | 8. SPRING         |
| 2. HANDLE                | 9. PIN            |
| 3. CLIP                  | 10. RING ASSEMBLY |
| 4. STOP                  | 11. ROD           |
| 5. SCREW (4), WASHER (4) | 12. PACKING       |
| 6. BRACKET W/HOOK        | 13. SLEEVE        |
| 7. ROD ASSEMBLY          | 14. PACKING       |

**REMOVAL**

- FOLLOW NUMERICAL SEQUENCE.
- ITEM 1: REMOVE OUTER SETSCREW, THEN LOOSEN OR REMOVE INNER SETSCREW.
  - ITEM 6: REMOVE HOOK ARM FROM RING.
  - ITEM 7: UNSCREW ROD ASSEMBLY FROM SLEEVE BY TURNING CLOCKWISE AS VIEWED FROM TOP.
  - ITEMS 9 AND 10: NORMALLY NOT REMOVED FROM ROD.

**INSTALLATION AND ADJUSTMENT**

- REVERSE REMOVAL PROCEDURE.
- ITEM 13: TIGHTEN TO 90-110 POUND-FEET.
  - ITEM 7: THREAD ROD ASSEMBLY COMPLETELY THROUGH THREADS OF SLEEVE. ADJUST BY ENGAGING THREADS OF ROD INTO THREADS OF SLEEVE, AND THEN TURNING ROD CLOCKWISE (FROM TOP) SIX FULL TURNS. DO NOT ALLOW ROD TO TURN DURING BALANCE OF INSTALLATION.
  - ITEM 5: TIGHTEN TO 75-85 POUND-FEET.
  - ITEM 2: THREAD HANDLE ON ROD ASSEMBLY (WITHOUT TURNING ROD) UNTIL HANDLE TOUCHES SLEEVE. THEN TURN ROD CLOSEST WAY TO ALIGN FLAT OF ROD WITH SETSCREW HOLE (SEE INSET).
  - ITEM 1: INSTALL ONE SETSCREW AND TIGHTEN TO 8-10 POUND-FEET, THEN INSTALL SECOND SETSCREW AND TIGHTEN TO 8-10 POUND-FEET.

CHECK OPERATION OF RELEASE MECHANISM AFTER INSTALLATION (FIG. 2-6.2).

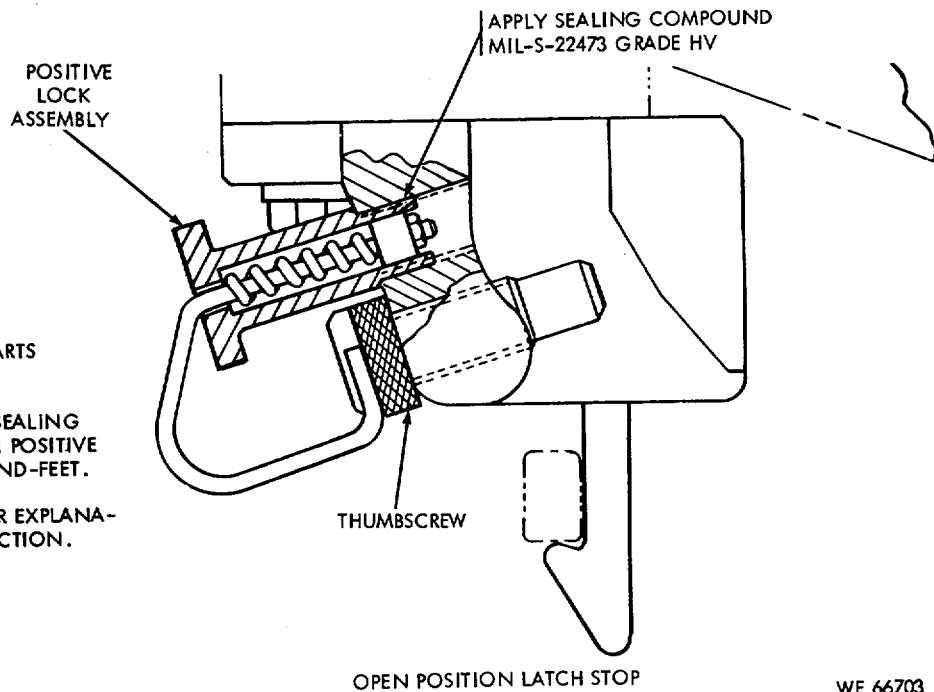

**REMOVAL/INSTALLATION**

REPLACE UNSERVICEABLE PARTS AS REQUIRED.

AT INSTALLATION, APPLY SEALING COMPOUND AND TIGHTEN POSITIVE LOCK BODY TO 15-20 POUND-FEET.

REFER TO FIGURE 2-6.2 FOR EXPLANATION OF LATCH STOP FUNCTION.

OPEN POSITION LATCH STOP

WE 66703

Figure 9-120.1. Removal/installation/adjustment - driver's rotatable hatch emergency outside latch release and open position latch stop

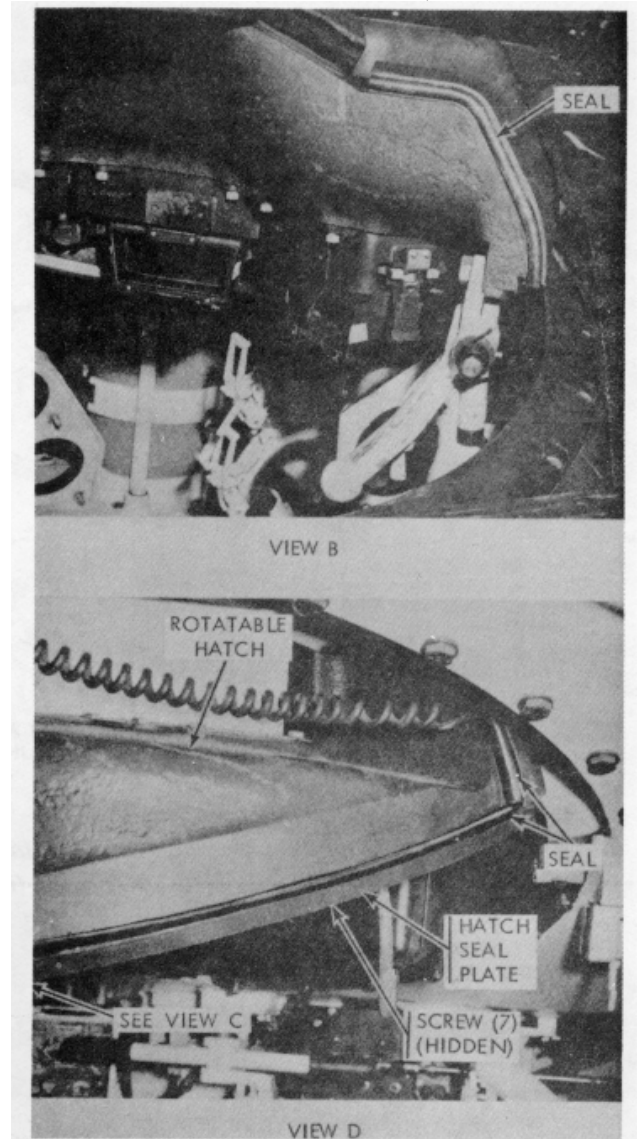
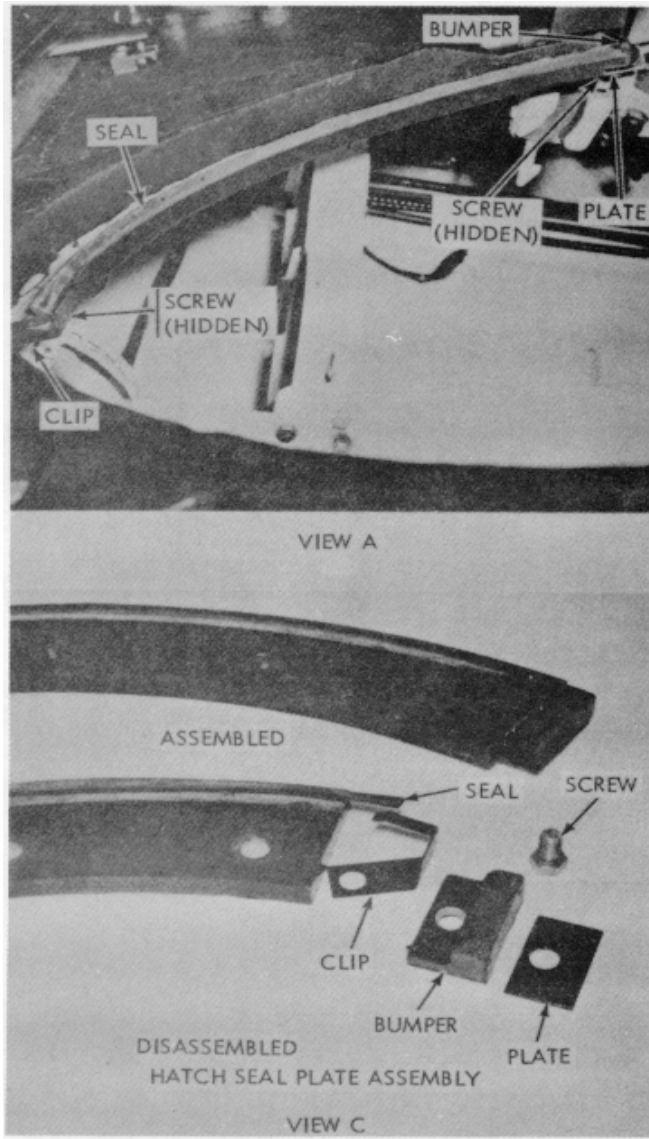

**REMOVAL**

1. REMOVE CLIP, RETAINER PLATE AND BUMPER (W/SLEEVE) FROM ENDS OF HULL SEAL PLATE (VIEW A).
2. REMOVE SEVEN SCREWS AND REMOVE HATCH SEAL PLATE FROM ROTATABLE HATCH. (VIEW D).
3. REMOVE SCREW, RETAINER PLATE, BUMPER (W/SLEEVE) AND SEAL CLIP FROM HATCH SEAL PLATE (VIEW C).
4. USE SUITABLE TOOL TO STRIP OFF OLD SEALS (VIEWS A, B, D). CLEAN SEAL GROOVES TO BARE METAL.

**INSTALLATION**

1. WHEN REPLACING SEALS, ALSO REPLACE BUMPERS.
2. USE ADHESIVE MIL-A-5092 TYPE II TO INSTALL NEW SEALS AND NEW BUMPERS. FOLLOW INSTRUCTIONS IN PARAGRAPH 8-6 FOR APPLICATION OF ADHESIVE.
3. REINSTALL CLIPS AND RETAINER PLATES IN ORIGINAL LOCATIONS.
4. ON HATCH SEAL PLATE, LET UPPER LIP OF SEAL EXTEND BEYOND SEAL PLATE AS SHOWN IN VIEW C. CEMENT LIP TO TOP OF BUMPER AT ASSEMBLY, AND TRIM FLUSH WITH BUMPER.

Figure 9-121. Removal/installation - driver's rotatable hatch seals

WE 66594

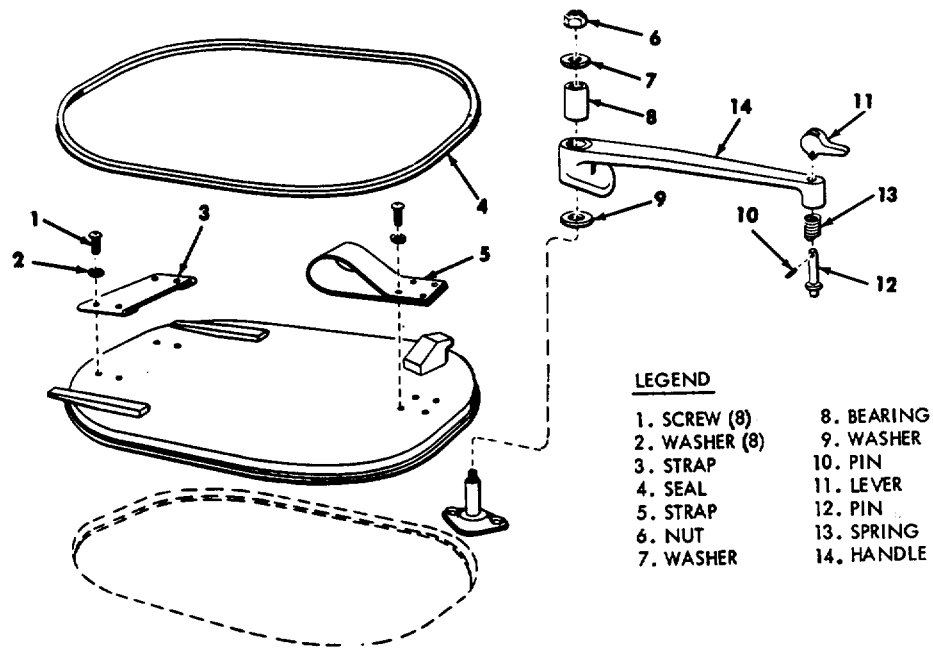

**REMOVAL/INSTALLATION**

REPLACE UNSERVICEABLE ITEMS AS REQUIRED.

**NOTE.** STRIP OFF OLD SEAL AND SCRAPE DIRT AND ADHESIVE FROM SEAL SURFACE. APPLY ADHESIVE 8040-285-1104 AND PRESS NEW SEAL INTO POSITION. ALLOW ADHESIVE TO DRY BEFORE REPLACING COVER ON VEHICLE. WE 11156A

Figure 9-122. Removal/Installation - driver's aluminum escape hatch cover (early vehicles)

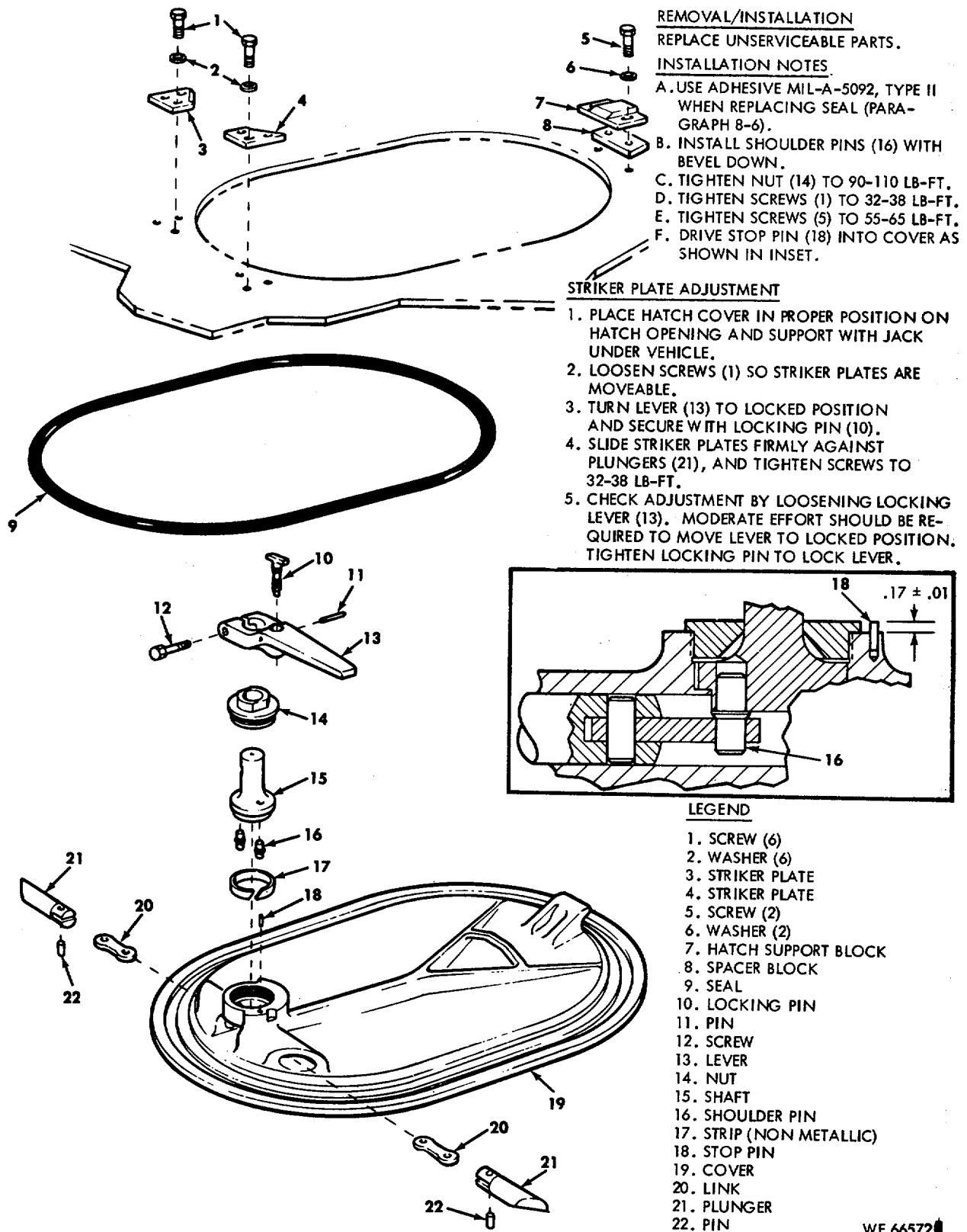

WE 66572

Figure 9-122.1. Removal/Installation - driver's steel escape hatch cover (later vehicles)

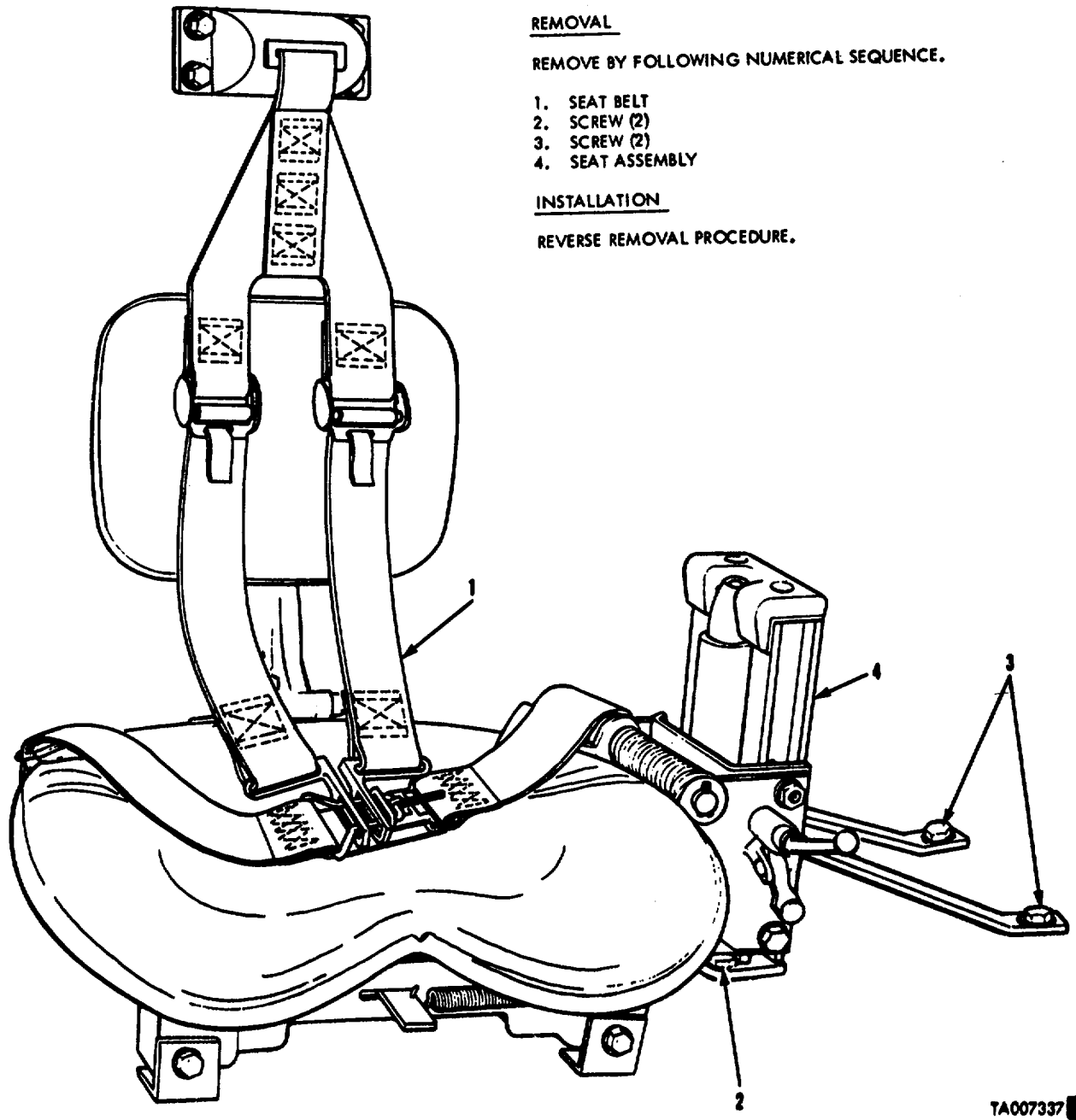

REMOVAL

REMOVE BY FOLLOWING NUMERICAL SEQUENCE.

1. SEAT BELT
2. SCREW (2)
3. SCREW (2)
4. SEAT ASSEMBLY

INSTALLATION

REVERSE REMOVAL PROCEDURE.

TA007337

Figure 9-123. Removal/installation - driver's seat and components.

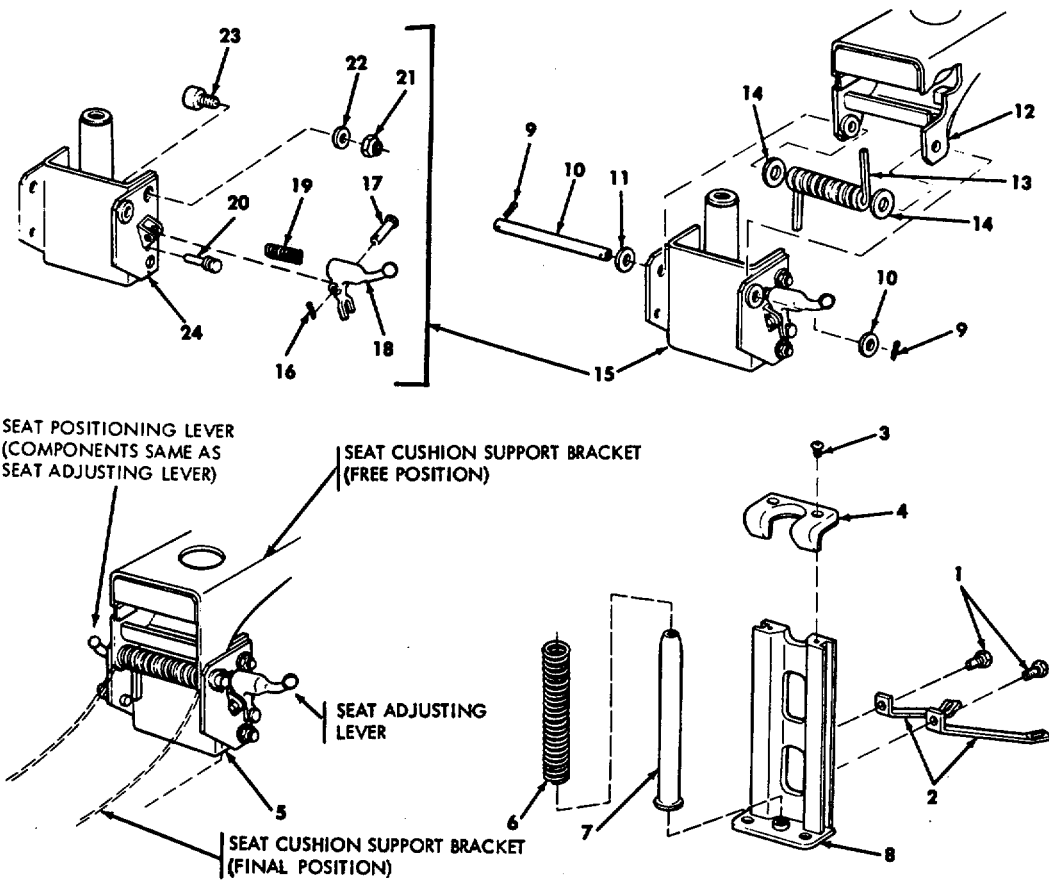

**LEGEND**

- |                                       |   |                      |
|---------------------------------------|---|----------------------|
| 1. SCREW (2)                          | 9. COTTER PIN (2)                           | 17. HEADED PIN (2)   |
| 2. BRACE (1 LEFT HAND, 1 RIGHT HAND)  | 10. FLAT WASHER (2)                         | 18. LEVER (2)        |
| 3. SCREW (2)                          | 11. SHAFT                                   | 19. SPRING (2)       |
| 4. PAD                                | 12. SEAT CUSHION SUPPORT GROUP (FIG. 9-125) | 20. LOCK PIN (2)     |
| 5. SEAT CUSHION SUPPORT/BRACKET GROUP | 13. TORSION SPRING                          | 21. NUT (4)          |
| 6. SPRING                             | 14. WASHER (2)                              | 22. FLAT WASHER (4)  |
| 7. GUIDE                              | 15. SEAT SUPPORT BRACKET GROUP              | 23. CAM FOLLOWER (4) |
| 8. SEAT SUPPORT                       | 16. COTTER PIN (2)                          | 24. BRACKET          |

**DISASSEMBLY**

DISASSEMBLE IN NUMERICAL SEQUENCE.

**NOTES.** 1. TO RELEASE ITEMS 5, 6, AND 7, LIFT UP ON SEAT ADJUSTING LEVER.

**CAUTION:** SPRING UNDER COMPRESSION.

2. ALLOW SEAT CUSHION SUPPORT BRACKET TO ASSUME FREE POSITION BY LIFTING UP ON SEAT POSITIONING LEVER.

**CAUTION:** TO PREVENT INJURY TO PERSONNEL, SEAT SUPPORT BRACKET AND BRACKET SUPPORT MUST BE RETAINED WHILE RELEASING SEAT POSITIONING LEVER.

**ASSEMBLY**

REVERSE DISASSEMBLY PROCEDURE.

WE 11064A

Figure 9-124. Disassembly/assembly - driver's seat and components (1 of 2)

LEGEND

1. SCREW (4)
2. WASHER (4)
3. BACK REST PAD
4. NUT (2)
5. SCREW (2)
6. FLAT WASHER (4)
7. BACK REST PLATE
8. SET SCREW
9. NUT
10. NUT
11. SCREW
12. BACK REST SUPPORT
13. COTTER PIN
14. HEADED PIN
15. PAWL
16. SPRING
17. NUT (4)
18. FLAT WASHER (4)
19. BRACKET
20. SPRING
21. COTTER PIN
22. HEADED PIN
23. ADJUSTMENT LEVER
24. NUT (4)
25. LOCK WASHER (4)
26. FLAT WASHER (4)
27. SEAT CUSHION
28. SHOCK MOUNT (4)
29. SHOCK MOUNT BRACKET
30. SLIDE TUBE
31. SEAT CUSHION SUPPORT BRACKET
32. NUT (2)
33. WASHER (2)
34. SCREW (2)
35. STOP
36. SAFETY BELT

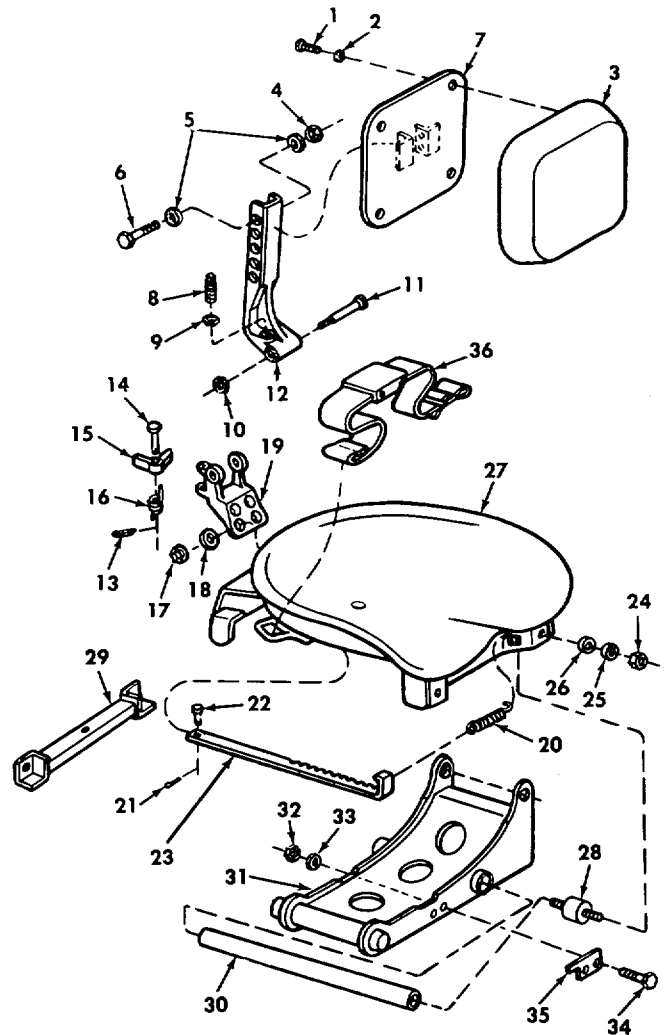
DISASSEMBLY

DISASSEMBLE IN NUMERICAL SEQUENCE.

**NOTE.** TO REMOVE SEAT CUSHION (ITEM 27) LET SLOTS IN REAR BRACKET CLEAR REAR SHOCK MOUNTS (ITEM 28) AND REMOVE SEAT, LETTING SCREW HOLES IN FORWARD BRACKET CLEAR THREADS ON FORWARD SHOCK MOUNTS.

ASSEMBLY

REVERSE DISASSEMBLY PROCEDURE.

WE 66701■

Figure 9-125. Disassembly/assembly - driver's seat and components (2 of 2)

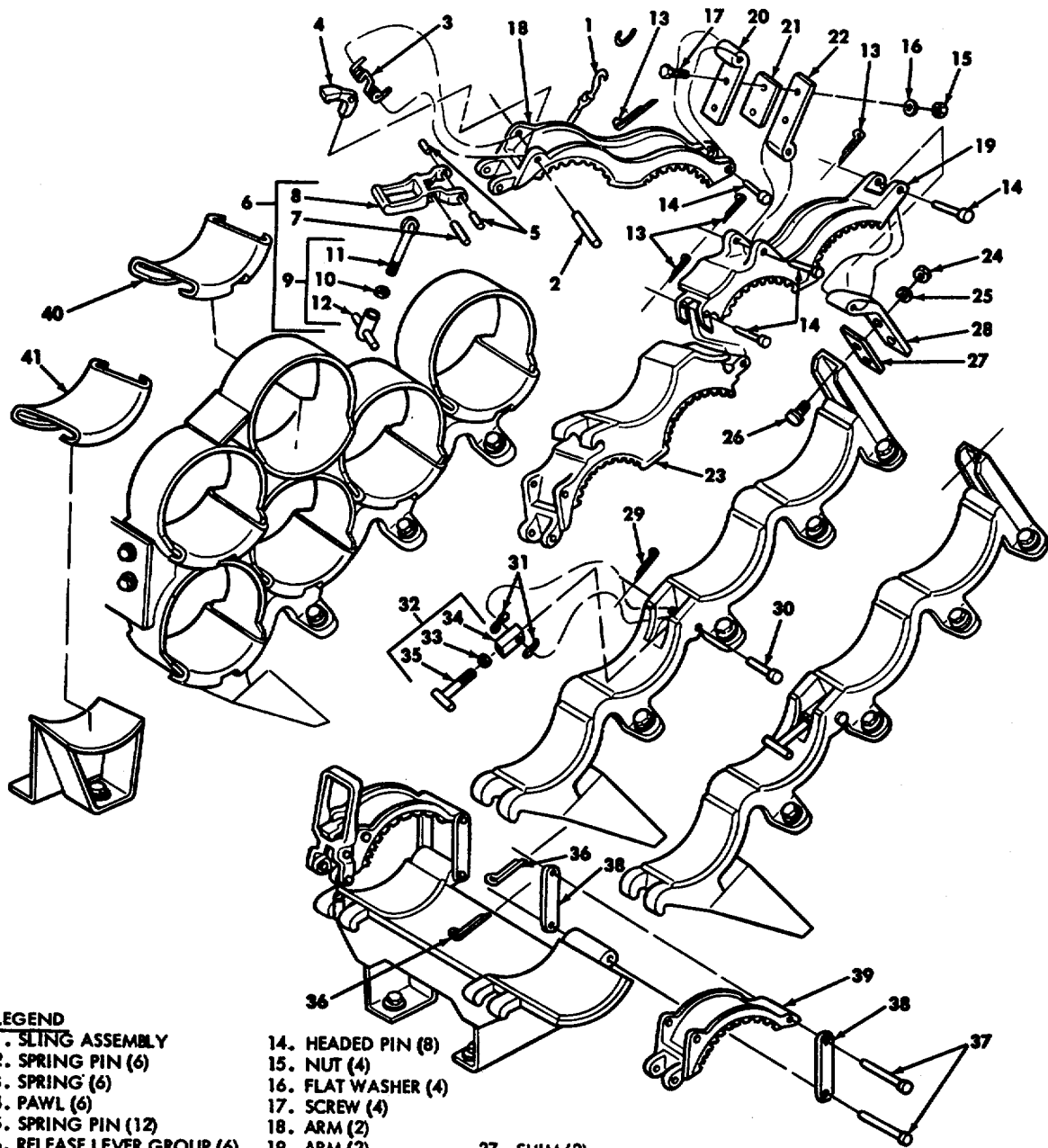

**LEGEND**

- |                            |                     |                       |                    |
|----------------------------|---------------------|-----------------------|--------------------|
| 1. SLING ASSEMBLY          | 14. HEADED PIN (8)  | 27. SHIM (2)          | 35. CATCH (2)      |
| 2. SPRING PIN (6)          | 15. NUT (4)         | 28. HINGE (2)         | 36. COTTER PIN (4) |
| 3. SPRING (6)              | 16. FLAT WASHER (4) | 29. COTTER PIN (2)    | 37. HEADED PIN (4) |
| 4. PAWL (6)                | 17. SCREW (4)       | 30. HEADED PIN (2)    | 38. LINK (4)       |
| 5. SPRING PIN (12)         | 18. ARM (2)         | 31. SPRING WASHER (4) | 39. ARM (2)        |
| 6. RELEASE LEVER GROUP (6) | 19. ARM (2)         | 32. CATCH GROUP (2)   | 40. PAD (6)        |
| 7. SPRING PIN (6)          | 20. HINGE (2)       | 33. NUT (2)           | 41. PAD } SEE NOTE |
| 8. LEVER (6)               | 21. SHIM (2)        | 34. SOCKET (2)        |                    |
| 9. CATCH GROUP (6)         | 22. HINGE (2)       |                       |                    |
| 10. NUT (6)                | 23. ARM (2)         |                       |                    |
| 11. BOLT (6)               | 24. NUT (4)         |                       |                    |
| 12. CATCH (6)              | 25. FLAT WASHER (4) |                       |                    |
| 13. COTTER PIN (8)         | 26. SCREW (4)       |                       |                    |

**REMOVAL/DISASSEMBLY**

REMOVE BY FOLLOWING NUMERICAL SEQUENCE

**NOTE.** PADS (ITEMS 40 AND 41) MAY BE REMOVED WITHOUT REMOVING RACK COMPONENTS. WHEN INSTALLING PADS, REFER TO PARAGRAPH 8-6 AND APPLY ADHESIVE - 8040-664-4318.

**ASSEMBLY/INSTALLATION**

REVERSE REMOVAL/DISASSEMBLY PROCEDURE

WE 11047

Figure 9-126. Disassembly/assembly - hull ammunition racks (right side)

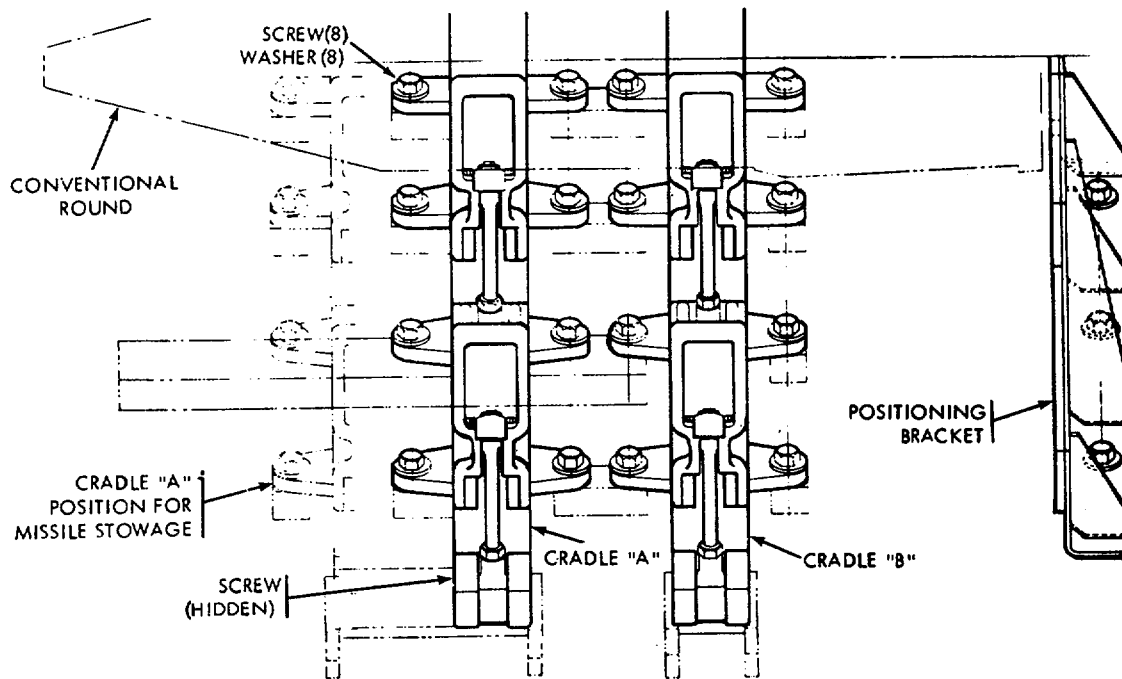

SIX-ROUND CRADLES ARE SHOWN IN POSITION FOR STORAGE OF CONVENTIONAL AMMUNITION. TO CONVERT TO MISSILE STORAGE, REMOVE 9 SCREWS AND MOVE CRADLE "A" TO POSITION INDICATED BY BROKEN LINES (APPROXIMATELY 3-1/4 INCHES FORWARD) TO PROVIDE PROPER SUPPORT FOR MISSILES. (CRADLE "B" AND POSITIONING BRACKET REMAIN IN THE SAME POSITION FOR BOTH APPLICATIONS).

TO CONVERT FROM MISSILE TO CONVENTIONAL AMMUNITION STORAGE, REVERSE ABOVE PROCEDURE. TIGHTEN ALL SCREWS TO 35 POUNDS-FEET.

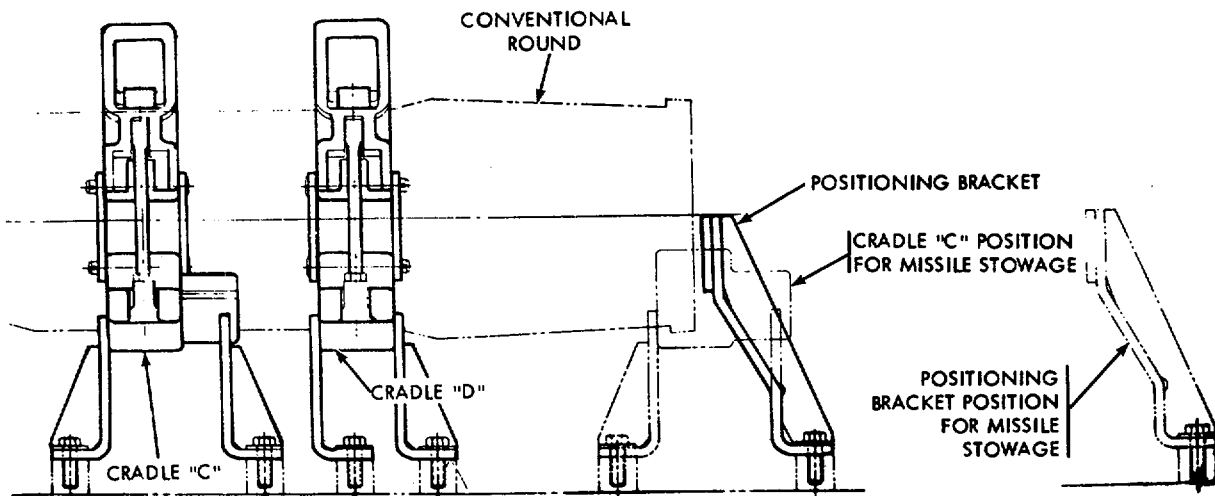

ONE-ROUND CRADLES AND POSITIONING BRACKET ARE SHOWN IN POSITION FOR STORAGE OF CONVENTIONAL AMMUNITION. TO CONVERT TO MISSILE STORAGE, MOVE POSITIONING BRACKET AND CRADLE "C" TO POSITIONS SHOWN BY BROKEN LINES. (CRADLE "D" REMAINS IN THE SAME POSITION FOR BOTH APPLICATIONS).

TO CONVERT FROM MISSILE TO CONVENTIONAL AMMUNITION STORAGE, REVERSE ABOVE PROCEDURE. TIGHTEN ALL SCREWS TO 35 POUNDS-FEET. WE 11961

Figure 9-126.1. (Added) Hull right ammunition rack conversion - conventional round to missile and missile to conventional round stowage (effective vehicle S/N 700)



This page left blank intentionally.

**9-132.1**

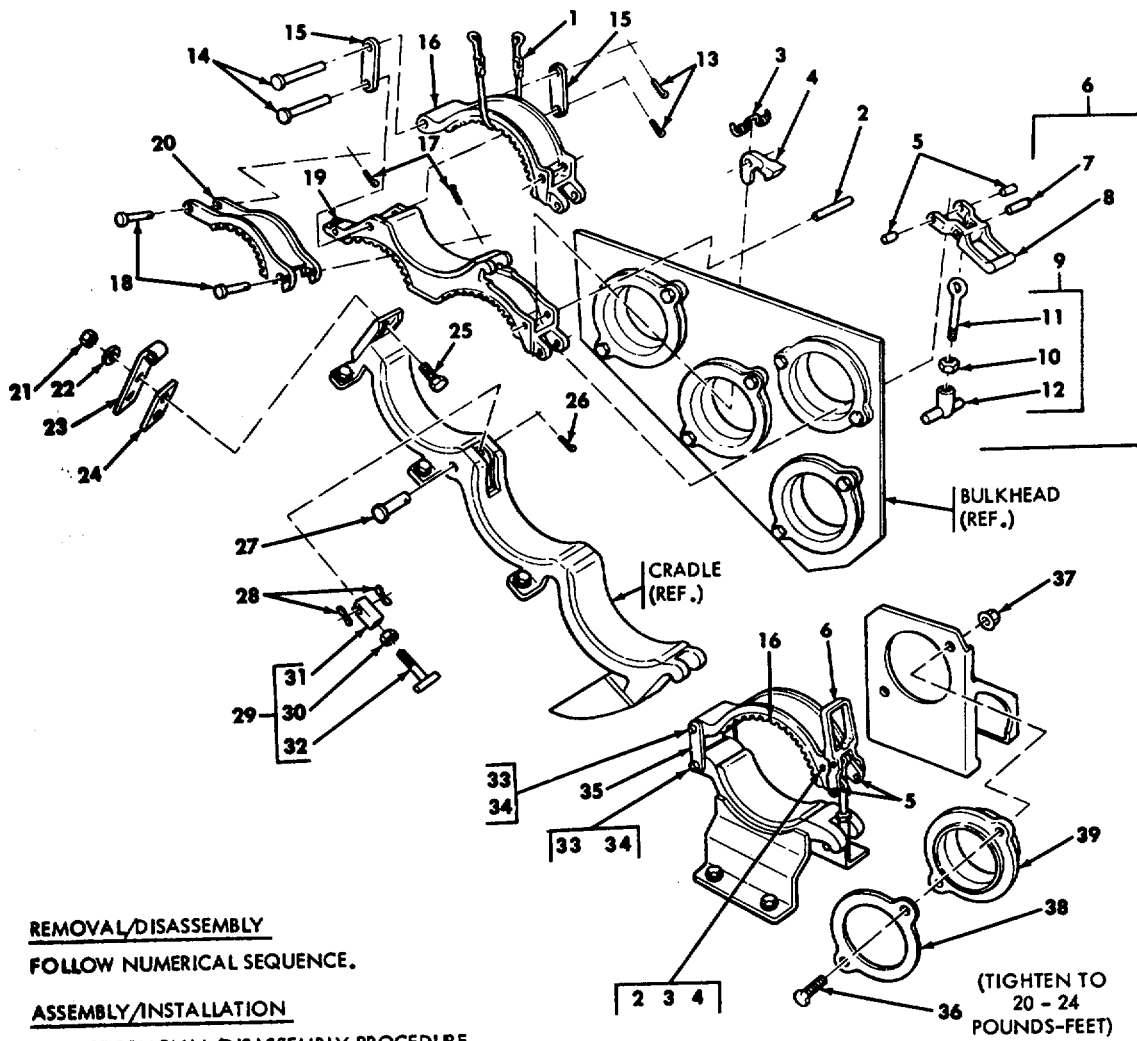

**REMOVAL/DISASSEMBLY**

FOLLOW NUMERICAL SEQUENCE.

**ASSEMBLY/INSTALLATION**

REVERSE REMOVAL/DISASSEMBLY PROCEDURE.

- |                            |                    |                       |                    |
|----------------------------|--------------------|-----------------------|--------------------|
| 1. SLING ASSEMBLY          | 11. BOLT (3)       | 21. NUT               | 31. SOCKET         |
| 2. SPRING PIN (3)          | 12. CATCH (3)      | 22. FLAT WASHER       | 32. CATCH          |
| 3. SPRING (3)              | 13. COTTER PIN (2) | 23. HINGE             | 33. COTTER PIN (2) |
| 4. PAWL (3)                | 14. HEADED PIN (2) | 24. SHIM              | 34. HEADED PIN (2) |
| 5. SPRING PIN (6)          | 15. LINK (2)       | 25. SCREW             | 35. LINK (2)       |
| 6. RELEASE LEVER GROUP (3) | 16. ARM (2)        | 26. COTTER PIN        | 36. SCREW (10)     |
| 7. SPRING PIN (3)          | 17. COTTER PIN (2) | 27. HEADED PIN        | 37. NUT (10)       |
| 8. LEVER (3)               | 18. HEADED PIN (2) | 28. SPRING WASHER (*) | 38. RETAINER (5)   |
| 9. CATCH GROUP (3)         | 19. ARM            | 29. CATCH GROUP       | 39. SUPPORT (5)    |
| 10. NUT (3)                | 20. ARM            | 30. NUT               |                    |

\* AS REQ'D

WE 11048

Figure 9-127. Disassembly/assembly - hull ammunition racks (left side, front)

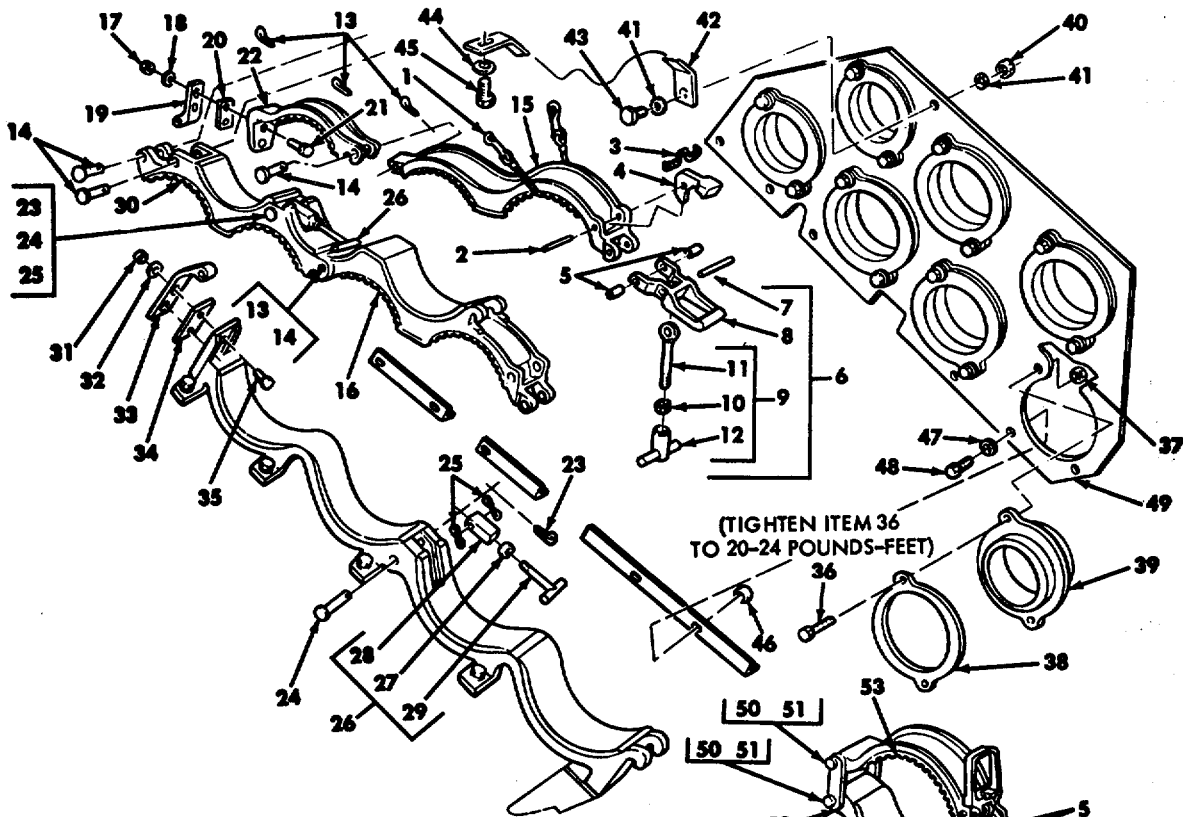

**LEGEND**

- |                            |                       |
|----------------------------|-----------------------|
| 1. SLING ASSEMBLY          | 22. ARM               |
| 2. SPRING PIN (3)          | 23. COTTER PIN (2)    |
| 3. SPRING (3)              | 24. HEADED PIN (2)    |
| 4. PAWL (3)                | 25. SPRING WASHER (*) |
| 5. SPRING PIN (6)          | 26. CATCH GROUP (2)   |
| 6. RELEASE LEVER GROUP (3) | 27. NUT (2)           |
| 7. SPRING PIN (3)          | 28. SOCKET (2)        |
| 8. RELEASE LEVER (3)       | 29. CATCH (2)         |
| 9. CATCH GROUP (3)         | 30. ARM               |
| 10. NUT (3)                | 31. NUT               |
| 11. BOLT (3)               | 32. FLAT WASHER       |
| 12. CATCH (3)              | 33. HINGE             |
| 13. COTTER PIN (4)         | 34. SHIM              |
| 14. HEADED PIN (4)         | 35. SCREW             |
| 15. ARM                    | 36. SCREW (16)        |
| 16. ARM                    | 37. NUT (16)          |
| 17. NUT                    | 38. RETAINER (8)      |
| 18. FLAT WASHER            | 39. SUPPORT (8)       |
| 19. HINGE                  | 40. NUT               |
| 20. SHIM                   | 41. FLAT WASHER (2)   |
| 21. SCREW                  | 42. BRACKET.          |
|                            | 43. SCREW             |
|                            | 44. FLAT WASHER       |
|                            | 45. SCREW             |
|                            | 46. NUT (5)           |
|                            | 47. FLAT WASHER (5)   |
|                            | 48. SCREW (5)         |
|                            | 49. PLATE             |
|                            | 50. COTTER PIN (2)    |
|                            | 51. HEADED PIN (2)    |
|                            | 52. LINK (2)          |
|                            | 53. ARM               |

\* AS REQUIRED

**REMOVAL/DISASSEMBLY**

REMOVE BY FOLLOWING NUMERICAL SEQUENCE.

**ASSEMBLY/INSTALLATION**

REVERSE REMOVAL/DISASSEMBLY PROCEDURE.

WE 11049

Figure 9-128. Disassembly/assembly - hull ammunition racks (left side, rear)

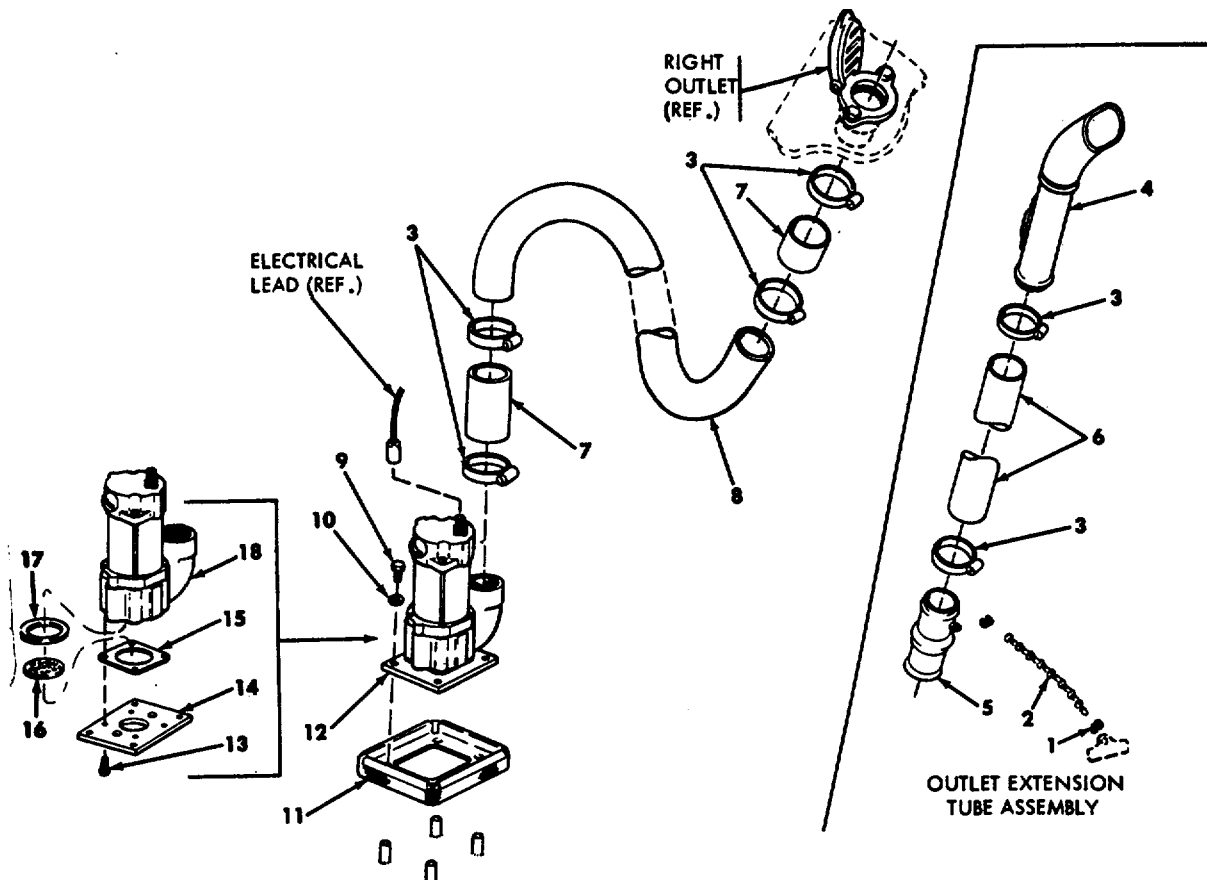

**LEGEND FOR BOTH RIGHT AND LEFT REAR BILGE PUMPS (RIGHT REAR SHOWN)**

- |  |                    |   |
|--|--------------------|---|
| 1. HOOKS (4)                                   | 9. SCREW (8)       | ] DISCARD BEFORE INSTALLING<br>NEW PUMP OR WHEN REPAIRING<br>PRESENT PUMP |
| 2. CHAIN (2)                                   | 10. FLATWASHER (8) |   |
| 3. CLAMP (12)                                  | 11. STRAINER (2)   |   |
| 4. TUBE (2)                                    | 12. PUMP GROUP     |   |
| 5. TUBE (2)                                    | 13. SCREW (8)      |   |
| 6. HOSE (2)                                    | 14. PLATE (2)      |   |
| 7. HOSE (4)                                    | 15. GASKET (2)     |   |
| 8. TUBE (RIGHT PUMP SHOWN, LEFT PUMP OPPOSITE) | 16. STRAINER (2)   |   |
|  | 17. SPACER (2)     |   |
|  | 18. PUMP (2)       |   |

**PRELIMINARY STEP**

REMOVE ENGINE ACCESS COVER REFER TO FIGURE 9-3.

**REMOVAL/DISASSEMBLY**

DISCONNECT ELECTRICAL LEAD (CIRCUIT NO. 722C FOR RIGHT PUMP, AND CIRCUIT NO. 722B FOR LEFT PUMP) AND REMOVE COMPONENTS BY FOLLOWING NUMERICAL SEQUENCE OR AS REQUIRED FOR REPLACEMENT OF UNSERVICEABLE COMPONENTS.

**ASSEMBLY/INSTALLATION**

REVERSE REMOVAL/DISASSEMBLY PROCEDURE

WE 11033A

Figure 9-129. (Superseded) Disassembly/assembly - rear bilge pumps and components

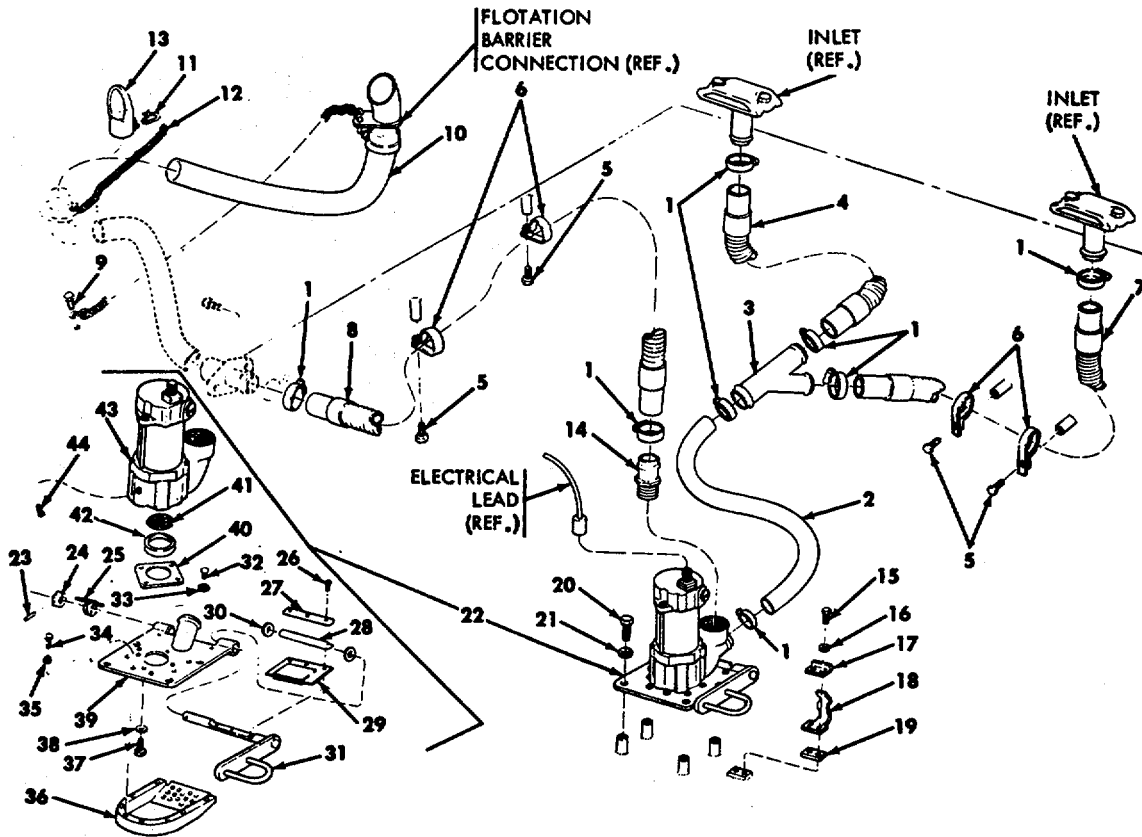

- |                      |                         |
|----------------------|-------------------------|
| 1. CLAMP (9)         | 23. SPRING PIN          |
| 2. HOSE ASSEMBLY     | 24. ADJUSTER            |
| 3. "Y" TUBE          | 25. TORSION SPRING      |
| 4. HOSE ASSEMBLY     | 26. SCREW (3)           |
| 5. SCREW (4)         | 27. RETAINER            |
| 6. CLAMP (4)         | 28. WIPER PLATE         |
| 7. HOSE ASSEMBLY     | 29. VALVE               |
| 8. HOSE ASSEMBLY     | 30. FLAT WASHER (2)     |
| 9. SCREW             | 31. ARM                 |
| 10. TUBE ASSEMBLY    | 32. SHORT SCREW (2)     |
| 11. COUPLER (2)      | 33. WASHER (2)          |
| 12. CHAIN            | 34. LONG SCREW (6)      |
| 13. OUTLET DEFLECTOR | 35. WASHER (6)          |
| 14. ADAPTER          | 36. CHAMBER             |
| 15. SCREW (2)        | 37. SCREW (4)           |
| 16. FLAT WASHER (2)  | 38. LOCK WASHER (4)     |
| 17. PLATE            | 39. PLATE               |
| 18. SPRING           | 40. GASKET              |
| 19. SPACER           | 41. STRAINER (SEE NOTE) |
| 20. SCREW (4)        | 42. SPACER (SEE NOTE)   |
| 21. FLAT WASHER (4)  | 43. PUMP                |
| 22. PUMP GROUP       | 44. DRIVE SCREW         |

**REMOVAL/DISASSEMBLY**

DISCONNECT ELECTRICAL LEAD (CIRCUIT NUMBER 723B) AND REMOVE COMPONENTS BY NUMERICAL SEQUENCE.

**ASSEMBLY/INSTALLATION**

REVERSE REMOVAL/DISASSEMBLY PROCEDURE. SEE NOTES, FIG. 131.

NOTE. ITEMS 41 (STRAINER) AND 42 (SPACER) SHOULD BE REMOVED AND DISCARDED WHEN INSTALLING NEW PUMP OR REPAIRING PRESENT PUMP.

WE 11034A

Figure 9-130. (Superseded) Disassembly/assembly - front bilge pump and components (1 of 2) (effective through vehicle serial no. 139)

## NOTES

1. WHEN INSTALLING NEW PUMP (ITEM 36) DISCARD 1/4 INCH THICK SHIPPING BLOCK THAT IS SUPPLIED WITH PUMP AND USE EXISTING SCREWS AND WASHERS. PLUG VENT HOLE WITH NEW DRIVE SCREW (ITEM 37).
2. ASSEMBLE CHAMBER TO PLATE APPLYING SEALER GRADE CV (8030-081-2330).
3. AFTER ASSEMBLING VALVE (ITEM 29), WIPER PLATE (ITEM 28), AND RETAINER (ITEM 27), TO ARM SHAFT (ITEM 31) WITH SCREWS (ITEM 26), STAKE HEADS OF SCREWS TO RETAINER.
4. TO PROVIDE PROPER PRELOAD ON TORSION SPRING (ITEM 25), ASSEMBLE TORSION SPRING AND ADJUSTER (ITEM 24) ON ARM SHAFT (ITEM 31) ROTATE ADJUSTER ONE SLOT IN A COUNTERCLOCKWISE DIRECTION AND ASSEMBLE SPRING PIN (ITEM 23).
5. WHEN ASSEMBLING HANDLE OF VALVE CONTROL ARM (ITEM 31) TO RETAINING SPRING (ITEM 18), GREASE SPRING WITH GAA GREASE AND ADJUST HEIGHT OF SPRING USING SPACERS (ITEM 19) TO PROVIDE CORRECT TRAVEL. (SEE BELOW).

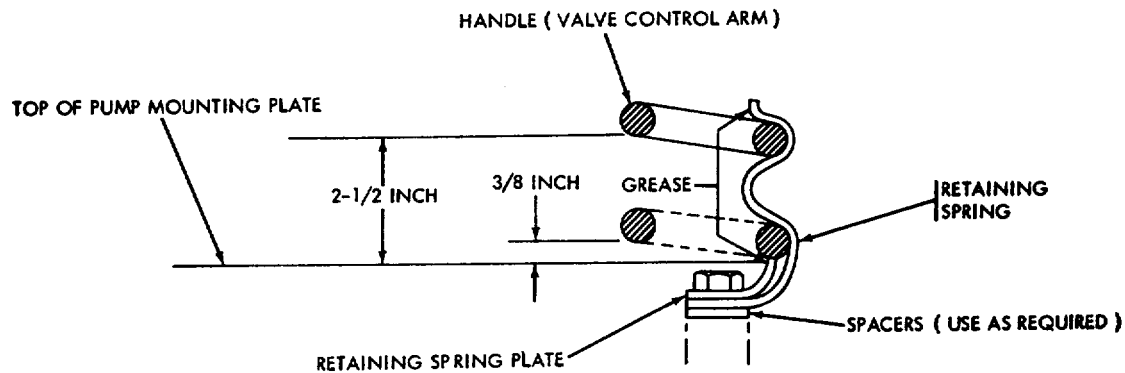

ADJUSTING TRAVEL OF VALVE CONTROL ARM HANDLE, FRONT BILGE PUMP

WE 11035C

Figure 9-131. (Superseded) Disassembly/assembly - front bilge pump and components  
(2 of 2) (effective through vehicle serial no. 139)

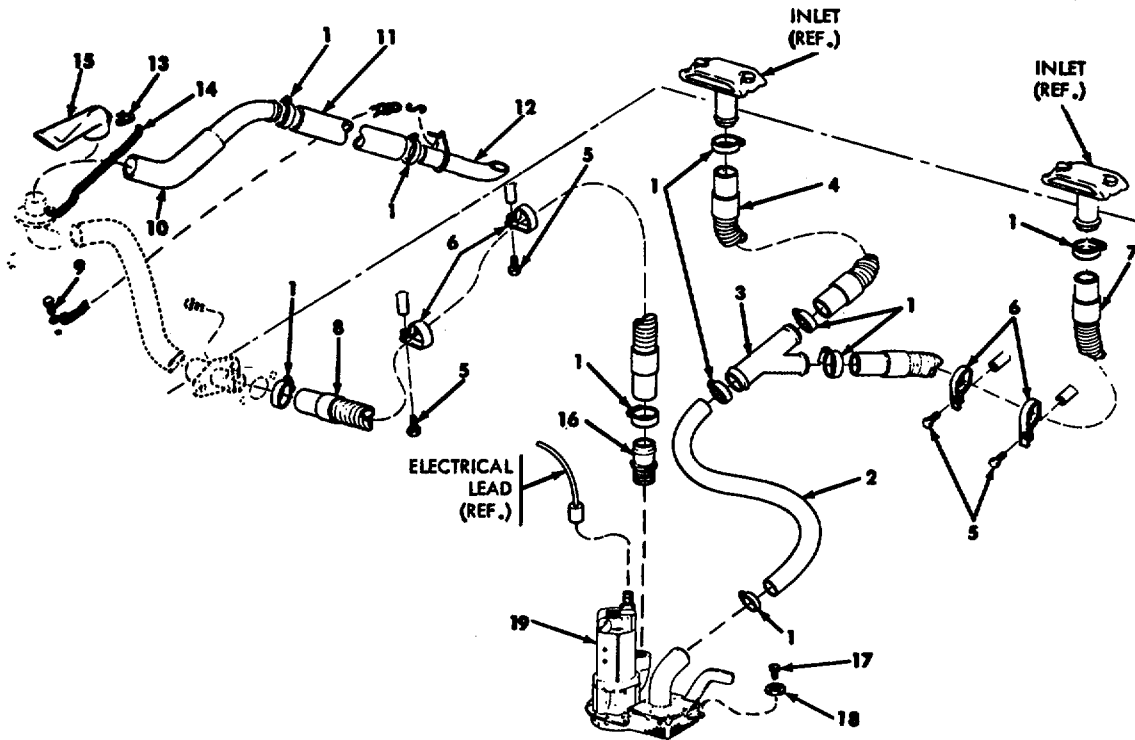

- |                  |                       |                      |
|------------------|-----------------------|----------------------|
| 1. CLAMP         | 8. HOSE ASSEMBLY      | 15. OUTLET DEFLECTOR |
| 2. HOSE          | 9. SCREW              | 16. ADAPTER          |
| 3. "Y" TUBE      | 10. TUBE ASSEMBLY     | 17. SCREW (3)        |
| 4. HOSE ASSEMBLY | 11. HOSE              | 18. WASHER (3)       |
| 5. SCREW (4)     | 12. OUTLET TUBE ASSY. | 19. PUMP             |
| 6. CLAMP (4)     | 13. COUPLER (2)       |                      |
| 7. HOSE ASSEMBLY | 14. CHAIN             |                      |

**REMOVAL/INSTALLATION**

DISCONNECT AND REPLACE UNSERVICEABLE COMPONENTS AS REQUIRED.

WE 11996

Figure 9-131.1 Removal installation - front bilge pump and components  
(effective vehicle serial no. 140)

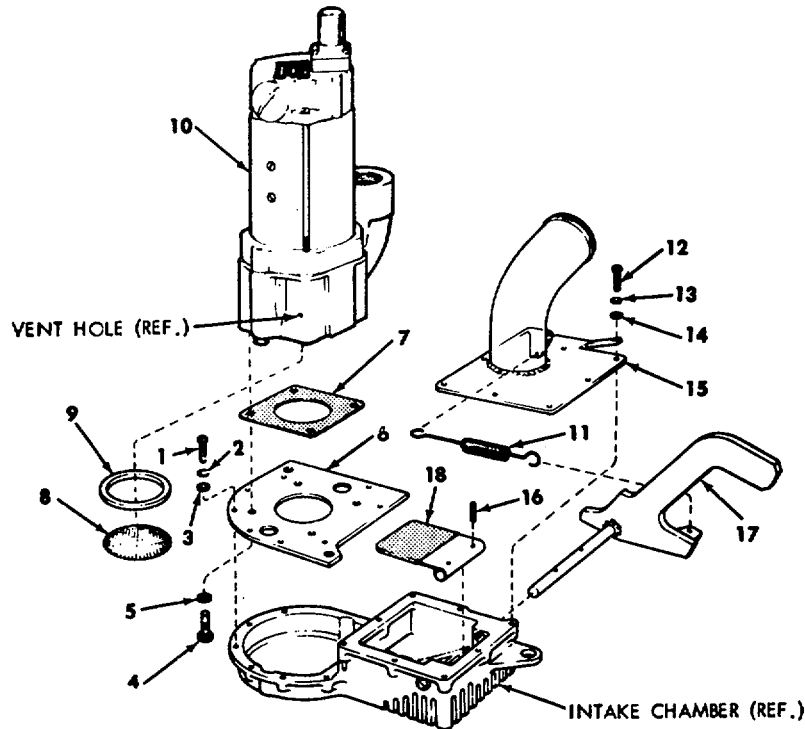

- |                  |                 |
|------------------|-----------------|
| 1. SCREW (8)     | 10. PUMP        |
| 2. WASHER (8)    | 11. SPRING      |
| 3. WASHER (8)    | 12. SCREW (8)   |
| 4. SCREW (4)     | 13. WASHER (8)  |
| 5. WASHER (4)    | 14. WASHER (8)  |
| 6. ADAPTER PLATE | 15. INLET COVER |
| 7. GASKET        | 16. PIN         |
| 8. STRAINER      | 17. LEVER       |
| 9. SPACER        | 18. INTAKE GATE |

#### DISASSEMBLY

DISASSEMBLE ITEMS 1 THROUGH 10, OR 11 THROUGH 18, IN NUMERICAL SEQUENCE. REPLACE UNSERVICEABLE COMPONENTS AS REQUIRED.

#### ASSEMBLY

REVERSE DISASSEMBLY PROCEDURE.

#### ASSEMBLY NOTES

1. WHEN INSTALLING NEW PUMP:
  - A. DISCARD SHIPPING BLOCK (ON BOTTOM OF PUMP) BUT REUSE SCREWS AND WASHERS.
  - B. DISCARD STRAINER (8) AND SPACER (9). (NEW PUMP MAY OR MAY NOT COME EQUIPPED WITH STRAINER AND SPACER.)
  - C. PLUG VENT HOLE WITH DRIVE SCREW 5305-253-5618. (VENT IS NOT REQUIRED FOR VERTICAL OPERATION.)
2. ITEMS 1 AND 12: APPLY SEALING COMPOUND GRADE CV, FSN 8030-081-2330.

WE 11944

Figure 9-131.2. (Added) Disassembly/assembly - front bilge pump and components (effective vehicle serial no. 140)



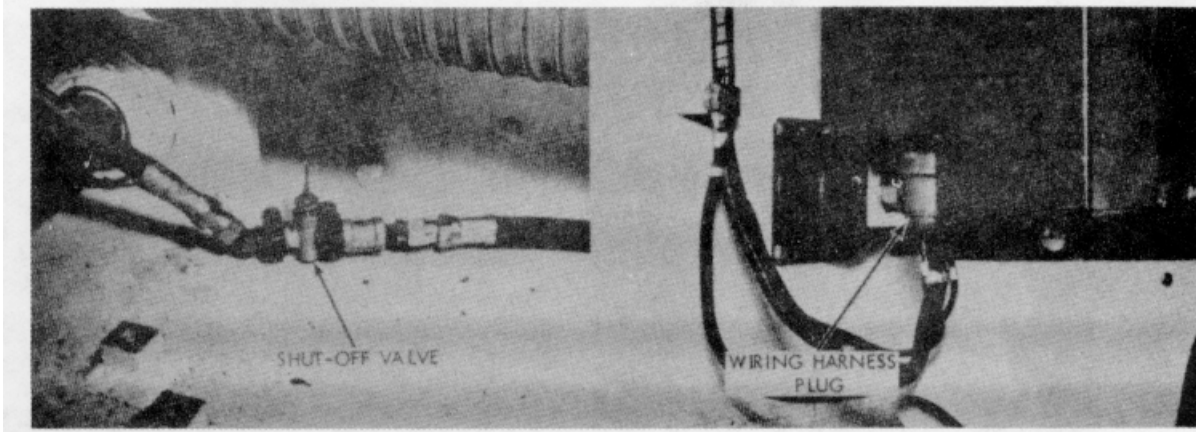

A. PLACE PERSONNEL HEATER FUEL SHUT-OFF VALVE IN "OFF" POSITION, AS SHOWN.

B. DISCONNECT WIRING HARNESS PLUG AT HEATER RECEPTACLE.

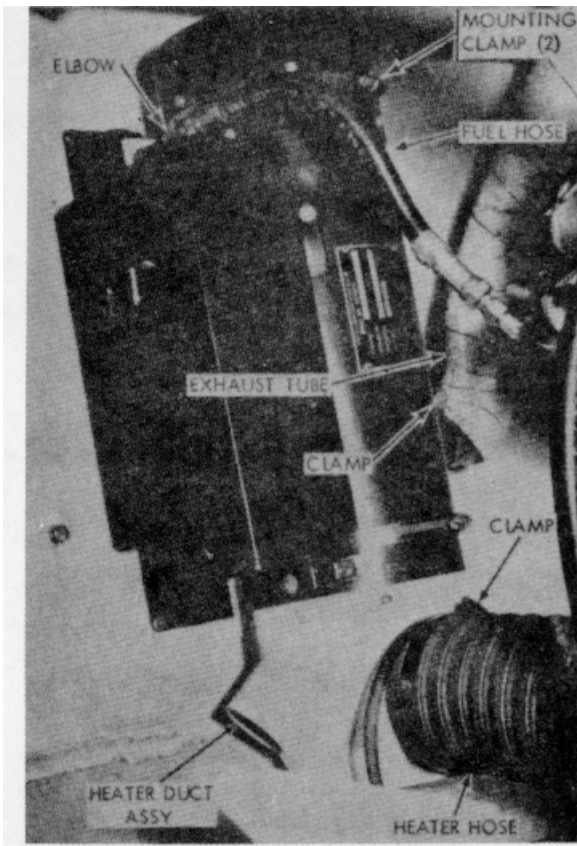

- C.
1. LOOSEN CLAMP AND REMOVE HEATER HOSE FROM HEATER DUCT ASSEMBLY.
  2. DISCONNECT FUEL HOSE AT HEATER ELBOW.
  3. LOOSEN CLAMP AND REMOVE HEATER EXHAUST TUBE FROM HEATER.
  4. DISCONNECT 2 CLAMPS AND REMOVE HEATER ASSEMBLY WITH DUCT ASSEMBLY.
  5. REMOVE 4 SCREWS AND DUCT ASSEMBLY FROM HEATER ASSEMBLY.

WE11257

Figure 9-132. (Superseded) Removal/installation - personnel heater

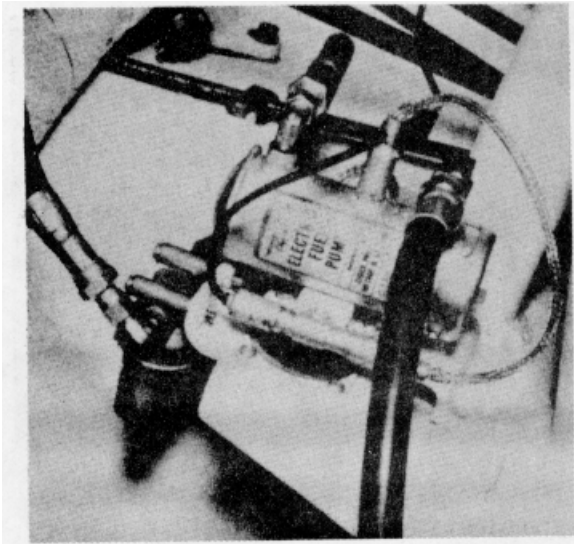

LEGEND

- |                  |                     |
|------------------|---------------------|
| 1. PUMP ASSEMBLY | 10. SCREW (2)       |
| 2. ELBOW         | 11. FILTER ASSEMBLY |
| 3. HOSE          | 12. ELBOW (2)       |
| 4. NUT (2)       | 13. HOSE ASSEMBLY   |
| 5. WASHER (4)    | 14. WASHER (2)      |
| 6. GROUND LEAD   | 15. SCREW (2)       |
| 7. SCREW (8)     | 16. ADAPTER         |
| 8. WASHER (2)    | 17. HOSE ASSEMBLY   |
| 9. CUSHION       |                     |

REMOVAL/INSTALLATION

REPLACE UNSERVICABLE COMPONENTS AS REQUIRED. REFER TO FIGURE 9-134 FOR FILTER AND PUMP SERVICE.

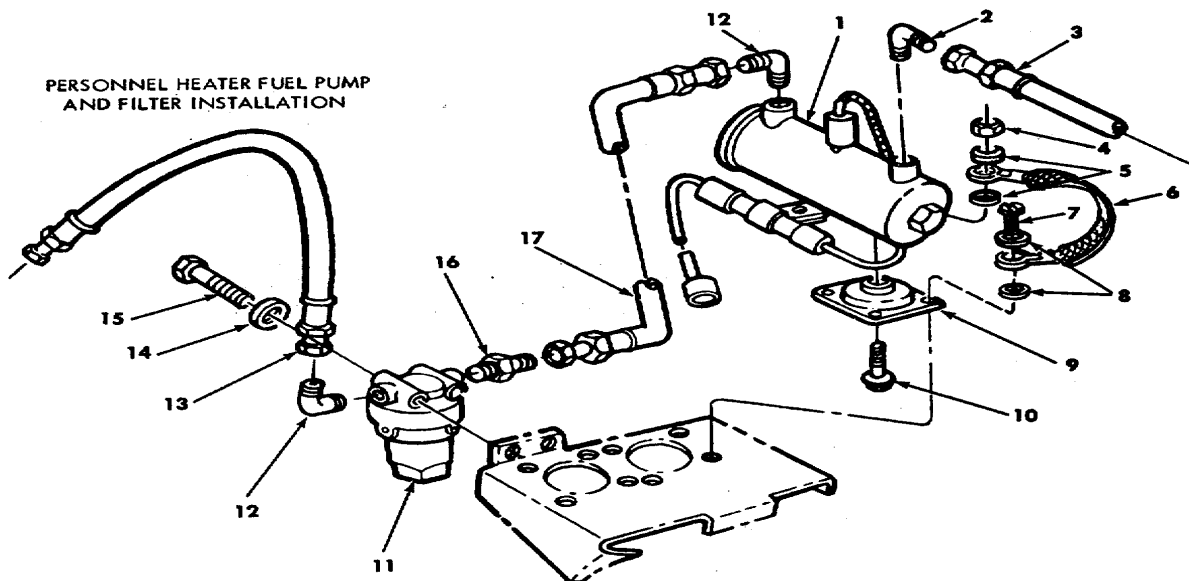

WE 11258

Figure 9-133. (Superseded) Removal/installation - personnel heater fuel pump, filter, valve, lines, and fittings

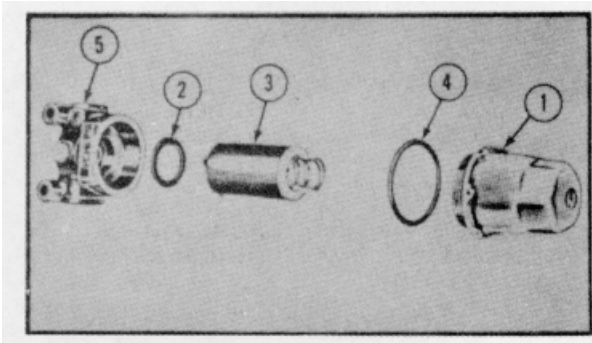

FUEL FILTER ASSEMBLY FOR:  
 PERSONNEL HEATER/COOLANT HEATER ..... 2915-025-3493  
 FUEL TANK DRAIN PUMP ..... 2940-930-3248  
 ELEMENT ASSEMBLIES ARE NOT INTERCHANGEABLE.

**LEGEND**

- |   |            |
|---|------------|
| 1. BOWL                                 | 4. PACKING |
| 2. WASHER                               | 5. HEAD    |
| 3. ELEMENT ASSY. (DO NOT REMOVE SPRING) |            |

**DISASSEMBLY**

UNSCREW BOWL FROM HEAD AND DISASSEMBLE AS REQUIRED. CLEAN FILTER ELEMENT IN DRY CLEANER SOLVENT OR MINERAL SPIRITS PAINT THINNER, AND DRY WITH LOW PRESSURE AIR.

**ASSEMBLY**

REVERSE DISASSEMBLY PROCEDURE. WE 11276A |

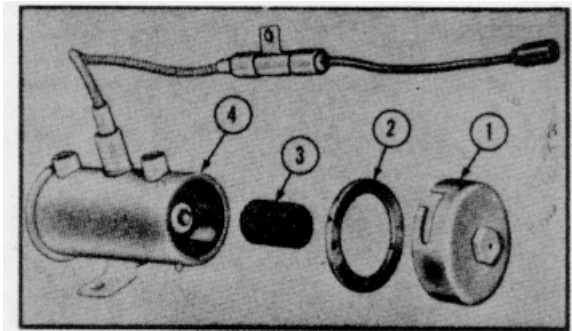

ELECTRIC FUEL PUMP  
 PERSONNEL HEATER/COOLANT HEATER (INTERCHANGEABLE)

**LEGEND**

- |           |            |
|-----------|------------|
| 1. CAP    | 3. FILTER  |
| 2. GASKET | 4. HOUSING |

**DISASSEMBLY**

UNLOCK CAP FROM HOUSING AND DISASSEMBLE PUMP BY FOLLOWING NUMERICAL SEQUENCE. CLEAN FILTER IN DRY CLEANING SOLVENT OR MINERAL SPIRITS PAINT THINNER, AND DRY WITH LOW PRESSURE AIR.

Y

**ASSEMBLY**

REVERSE DISASSEMBLY PROCEDURE.

Figure 9-134. (Superseded) Disassembly/assembly - Fuel filter-personnel heater, coolant heater, and fuel drain pump, Electric fuel pump - personnel heater and coolant heater.

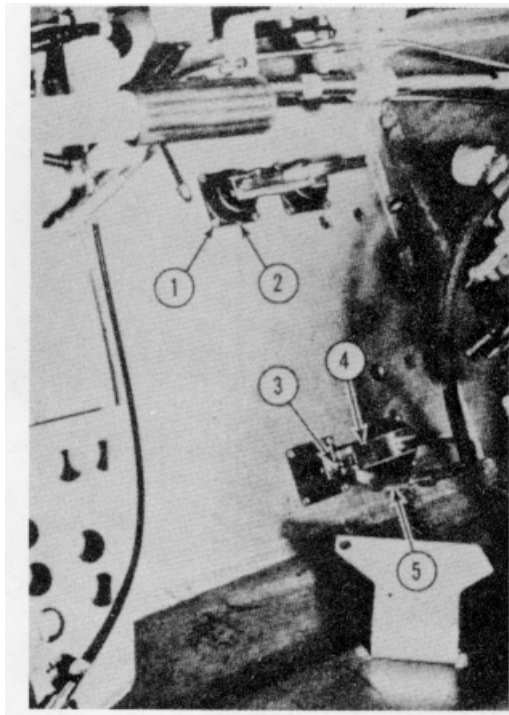

**LEGEND**

1. SCREW (16)
2. SHOCK MOUNT (4)
3. SCREW (4)
4. BRACKET (2)
5. CLAMP (2)

**REMOVAL**

REMOVE PERSONNEL HEATER SHOCK MOUNTS BY FOLLOWING NUMERICAL SEQUENCE.

**INSTALLATION**

REVERSE REMOVAL PROCEDURE.

Figure 9-135. Removal/installation - personnel heater shock mounts

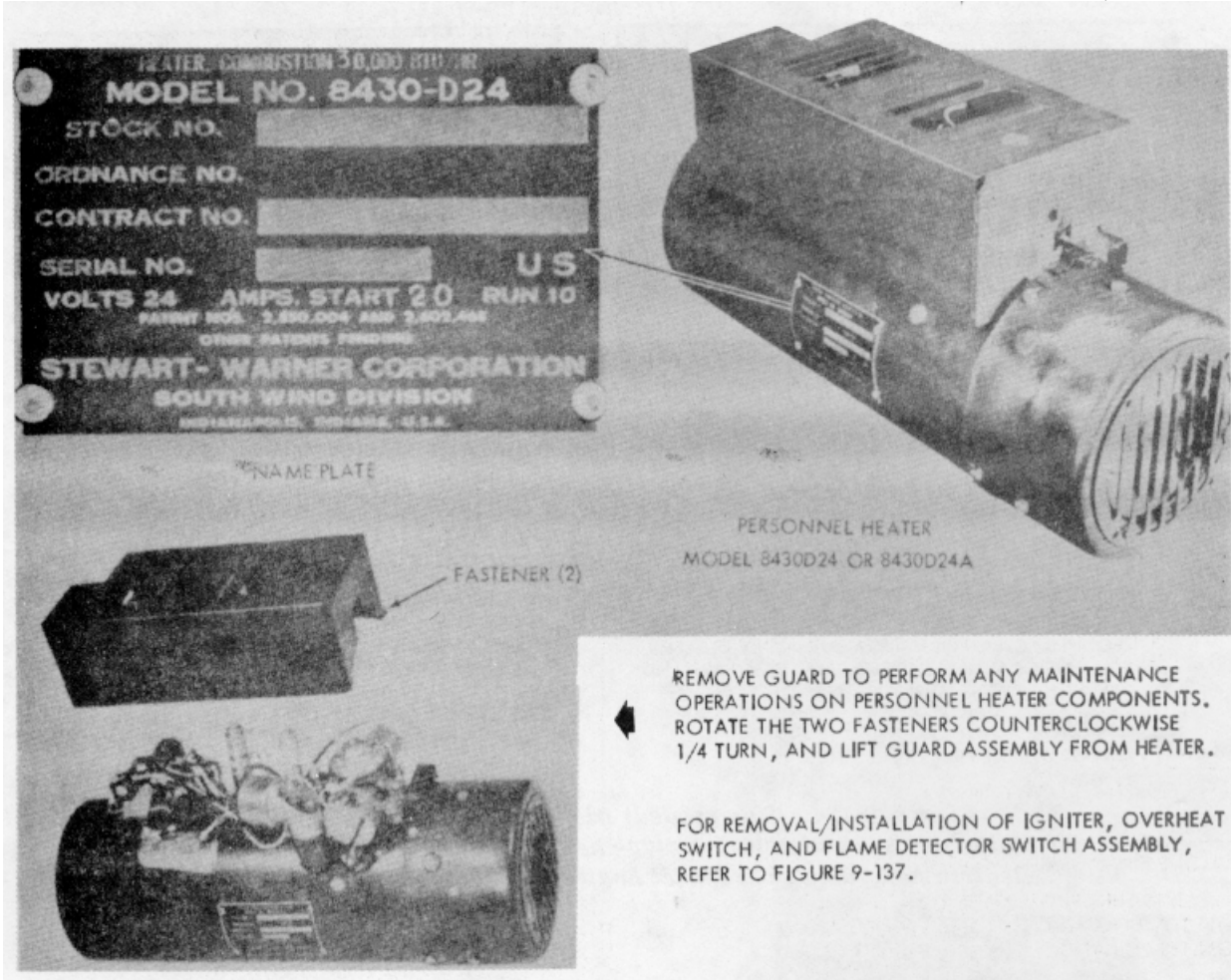

REMOVE GUARD TO PERFORM ANY MAINTENANCE OPERATIONS ON PERSONNEL HEATER COMPONENTS. ROTATE THE TWO FASTENERS COUNTERCLOCKWISE 1/4 TURN, AND LIFT GUARD ASSEMBLY FROM HEATER.

FOR REMOVAL/INSTALLATION OF IGNITER, OVERHEAT SWITCH, AND FLAME DETECTOR SWITCH ASSEMBLY, REFER TO FIGURE 9-137.

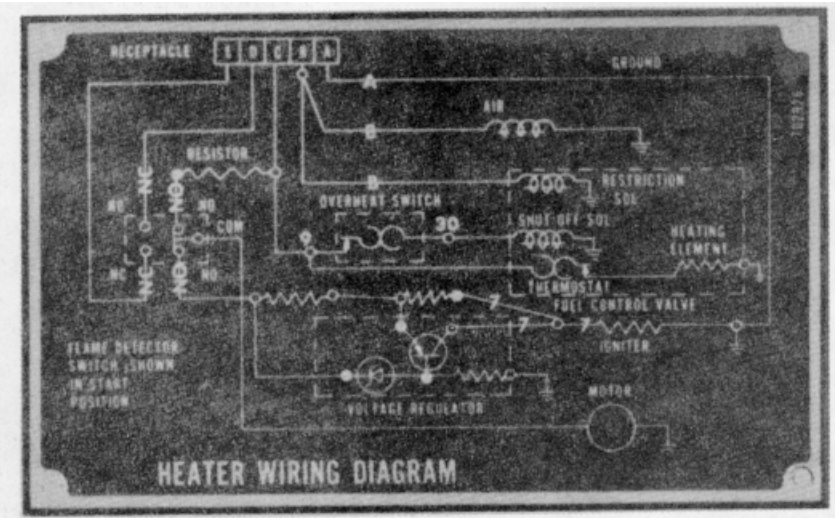

PERSONNEL HEATER WIRING DIAGRAM (LOCATED INSIDE GUARD) WE 11259 |

Figure 9-136. (Added) Removal/installation - personnel heater guard

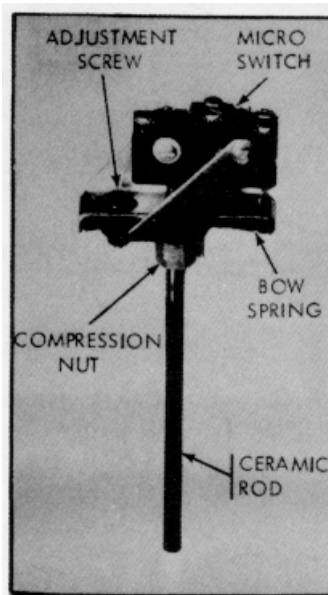

FLAME DETECTOR  
SWITCH ASSEMBLY

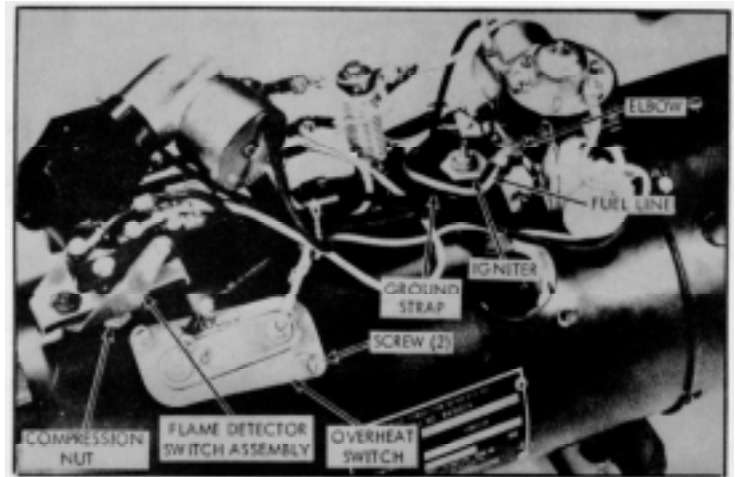

PERSONNEL HEATER IGNITER, OVERHEAT SWITCH, AND  
FLAME DETECTOR SWITCH.  
(AIR VALVE REMOVED FOR CLARITY) ,3

#### PRELIMINARY STEP

REMOVE GUARD ASSEMBLY FROM HEATER (FIGURE 9-136).

#### REMOVAL- IGNITER

1. REMOVE NUT AND TWO WIRES FROM TOP OF IGNITER
2. USE 13/16 THIN WALL DEEP SOCKET TO SEN IGNITER, HOLD GROUND STRAP DOWN AND UNSCREW IGNITER BY HAND.

NOTE. IF THIN WALL SOCKET IS NOT AVAILABLE, DISCONNECT FUEL LINE AND REMOVE 450 ELBOW AT THE FUEL CONTROL VALVE TO PROVIDE CLEARANCE FOR A STANDARD SOCKET.

3. REMOVE IGNITER FROM HEATER.

#### REMOVAL - OVERHEAT SWITCH

1. DISCONNECT 3 WIRES FROM OVERHEAT SWITCH TERMINALS.
2. REMOVE TWO SCREWS AND OVERHEAT SWITCH. REMOVAL - FLAME DETECTOR SWITCH ASSEMBLY 1. DISCONNECT FIVE WIRES FROM FLAME DETECTOR MICROSWITCH TERMINALS. REINSTALL TERMINAL SCREWS AND LOCKWASHERS TO PREVENT LOSS.
2. USE 1/2-INCH OPEN END WRENCH TO LOOSEN COMPRESSION NUT.
3. LIFT FLAME DETECTOR ASSEMBLY STRAIGHT OUT OF HOUSING TO AVOID BREAKING CERAMIC ROD.

#### FLAME DETECTOR SWITCH ADJUSTMENT

1. CHECK BOW SPRING TO SEE IF TENSION OF QUARTZ ROD IS CAUSING IT TO BOW UP TOWARD THE TOP OF THE SWITCH. IF SPRING IS NOT BOWED BUT IS IN A STRAIGHT POSITION, IT MAY BE ASSUMED THAT QUARTZ ROD IS BROKEN. REPLACE SWITCH.
2. IF SPRING IS BOWED, LOOSEN TWO SWITCH MOUNTING SCREWS UNTIL MICRO SWITCH CAN PIVOT.
3. BACK OFF ADJUSTING SCREW UNTIL SWITCH "CLICKS."
4. TURN ADJUSTING SCREW IN UNTIL SWITCH "CLICKS" AGAIN AND CONTINUE FOR ADDITIONAL 1/4 TURN FROM CLICK POINT. SWITCH IS NOW CORRECTLY ADJUSTED.
5. TIGHTEN TWO SWITCH MOUNTING SCREWS TO HOLD SWITCH IN PROPER POSITION.

NOTE.

WHEN INSTALLED, THIS SWITCH MUST OPERATE WITHIN 40 SECONDS AFTER HEATER IGNITES. AFTER HEATER GOES OUT OR IS SHUT OFF, SWITCH MUST NOT RE-OPERATE WITHIN 1 MINUTE BUT MUST RE-OPERATE WITHIN 3-1/2 MINUTES.

#### INSTALLATION

REVERSE REMOVAL PROCEDURE, REPLACING UNSERVICEABLE COMPONENTS AS REQUIRED. CONNECT WIRING AS SHOWN ON WIRING DIAGRAM, FIGURE 9-136. WHEN REPLACING FLAME DETECTOR SWITCH ASSEMBLY, RETURN OLD SWITCH ASSEMBLY TO SUPPORT MAINTENANCE FOR REPAIR AND RETURN TO STOCK.

Figure 9-137. Removal/installation - personnel heater igniter, overhear switch, and flame detector switch assembly

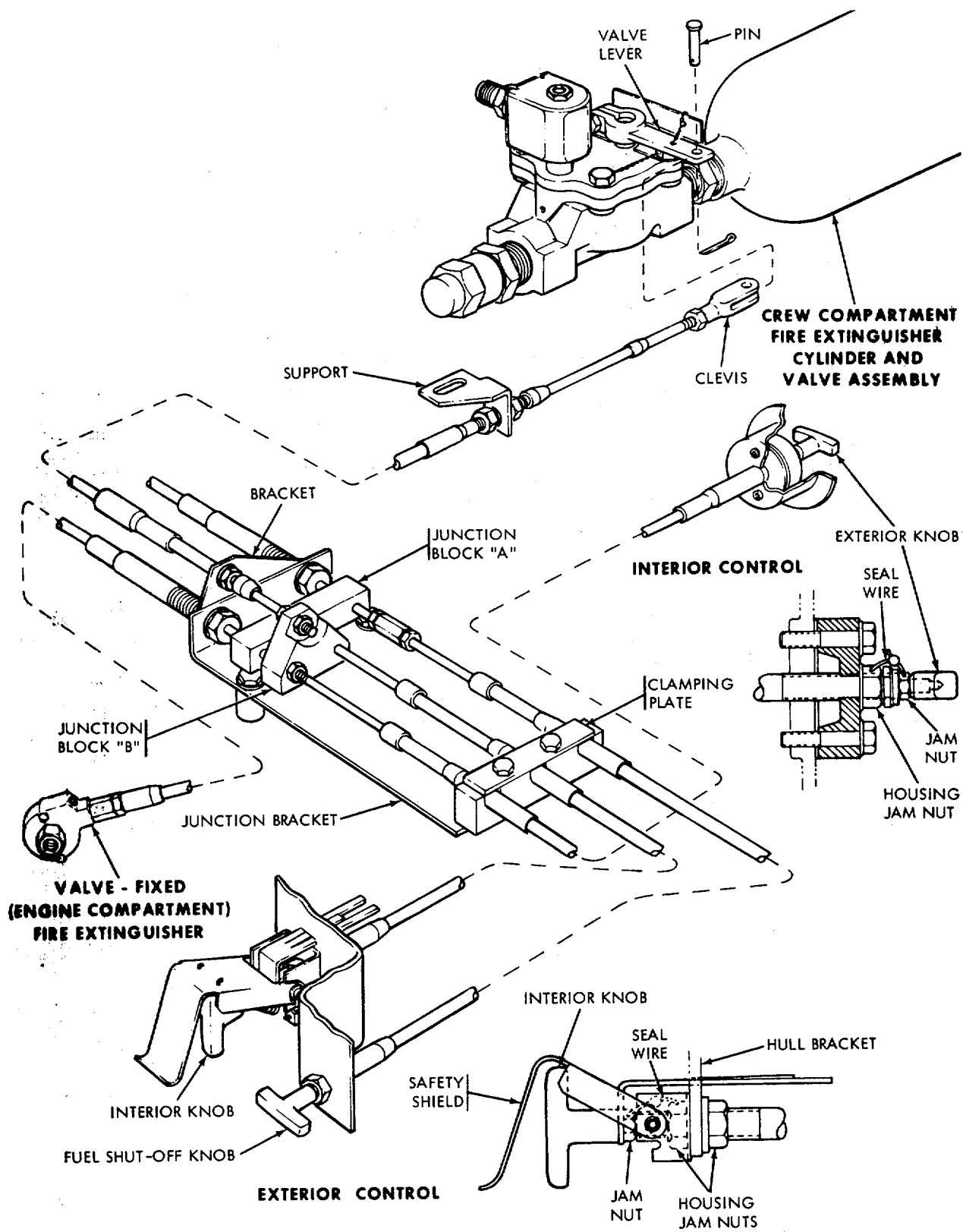

WE 66685

Figure 9-138. Adjustment - crew compartment and fixed (engine compartment) fire extinguisher control linkage (1 of 2)

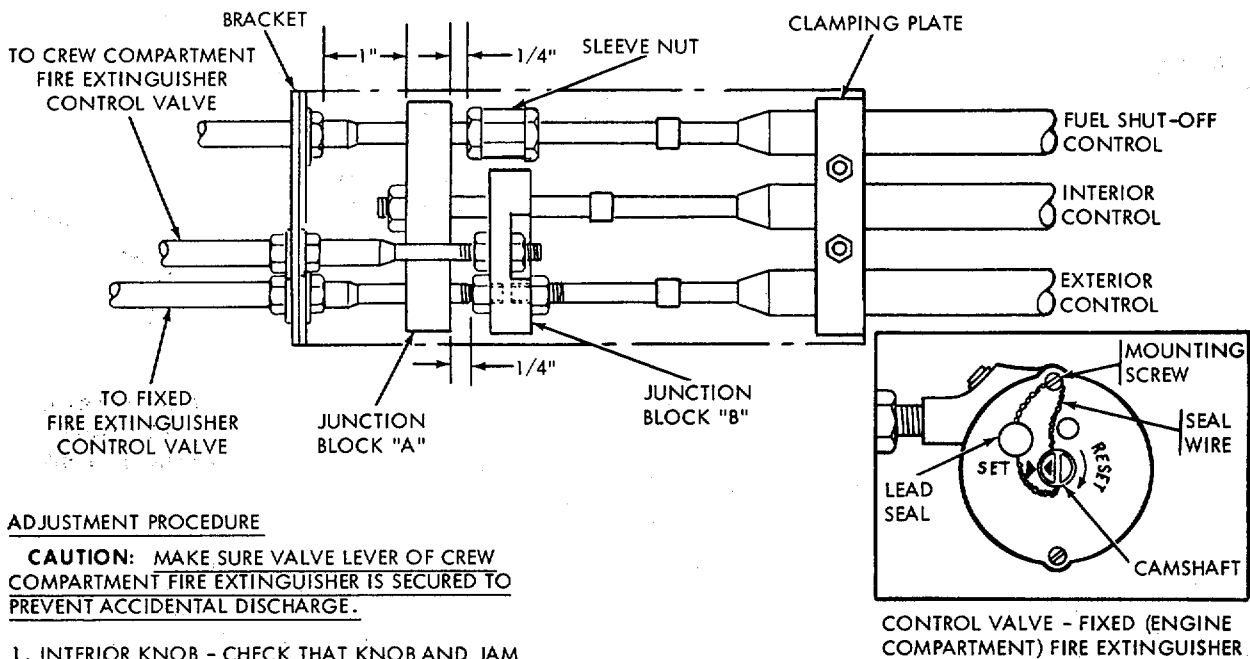

#### ADJUSTMENT PROCEDURE

**CAUTION:** MAKE SURE VALVE LEVER OF CREW COMPARTMENT FIRE EXTINGUISHER IS SECURED TO PREVENT ACCIDENTAL DISCHARGE.

1. INTERIOR KNOB - CHECK THAT KNOB AND JAM NUT ARE TIGHT ON CABLE. PUSH KNOB COMPLETELY IN, PUSH SAFETY SHIELD DOWN (AS SHOWN IN FIGURE 9-138), AND TIGHTEN HOUSING JAM NUTS ON HULL BRACKET.
2. EXTERIOR KNOB - CHECK THAT KNOB AND JAM NUT ARE TIGHT ON CABLE. TIGHTEN HOUSING JAM NUT. PUSH KNOB COMPLETELY IN AND INSTALL TEMPORARY SEAL WIRE (WITHOUT LEAD SEAL) PULLED TIGHT AND TWISTED TO HOLD KNOB IN WHILE MAKING ADJUSTMENTS.
3. DISCONNECT CLEVIS FROM VALVE LEVER OF CREW COMPARTMENT CYLINDER AND VALVE ASSEMBLY.
4. LOOSEN SWIVEL NUT AND REMOVE VALVE FROM FIXED (ENGINE COMPARTMENT) CYLINDER.
5. LOOSEN 2 SCREWS TO LOOSEN CLAMPING PLATE ON JUNCTION BRACKET.
6. ADJUST INTERIOR CONTROL CABLE, BY MOVING HOUSING UNDER CLAMPING PLATE, TO OBTAIN THE 1 INCH ADJUSTMENT SHOWN ABOVE. MARK HOUSING AT CLAMP PLATE, AND HOLD IN PLACE WHILE MAKING THE 1/4 INCH ADJUSTMENT ON EXTERIOR CONTROL CABLE (SHOWN ABOVE).
7. LOOSEN NUTS BOTH SIDES OF BRACKET ON FIXED FIRE EXTINGUISHER CABLE.
8. ADJUST EXTERIOR CONTROL CABLE BY MOVING HOUSING UNDER CLAMPING BRACKET TO OBTAIN THE 1/4 INCH DIMENSION SHOWN, WHILE HOLDING THE 1" DIMENSION (STEP 4). TIGHTEN CLAMPING PLATE SCREWS AND NUTS LOOSENED IN STEP 5.
9. REFER TO FIGURE 9-22 AND ADJUST FUEL SHUT-OFF CONTROL TO OBTAIN PROPER OPERATION BY MEANS OF FUEL SHUT-OFF KNOB. LOOSEN JAM NUTS AND ADJUST SLEEVE NUT TO OBTAIN THE 1/4 INCH DIMENSION SHOWN ABOVE. IF IT BECOMES NECESSARY TO LOOSEN CLAMPING PLATE, MAKE SURE PREVIOUS ADJUSTMENTS ARE NOT DISTURBED. TIGHTEN CLAMPING PLATE SCREWS AND/OR FUEL SHUT-OFF CONTROL JAM NUTS.
10. CHECK THAT ALL JAM NUTS IN JUNCTION BLOCK AREA HAVE BEEN TIGHTENED.
11. ADJUST CLEVIS ON CABLE ROD END SO THAT HOLE IN CLEVIS MATCHES HOLE IN VALVE LEVER. IF CLEVIS ADJUSTMENT RANGE IS INSUFFICIENT:
  - A. SOME ADDITIONAL ADJUSTMENT IS AVAILABLE BY MEANS OF JAM NUTS AT THE CABLE SUPPORT.
  - B. IF LARGER ADJUSTMENT IS REQUIRED, LOOSEN CYLINDER MOUNTING SCREWS AND MOVE CYLINDER AND VALVE ASSEMBLY AS REQUIRED. DO NOT ROTATE. TIGHTEN MOUNTING SCREWS.
12. AFTER ADJUSTMENTS ARE COMPLETED, INSTALL SEAL WIRES:
 

INTERIOR KNOB - INSTALL SEAL WIRE AS SHOWN IN FIGURE 9-139.

EXTERIOR KNOB - REMOVE TEMPORARY SEAL WIRE (STEP 2) AND INSTALL SEAL WIRE WITH LEAD SEAL AS SHOWN IN FIGURE 9-139.

FIXED (ENGINE COMPARTMENT) CONTROL VALVE - RESET AND INSTALL SEAL WIRE AS SHOWN IN INSET ABOVE. INSTALL VALVE ON CYLINDER.

CREW COMPARTMENT CONTROL VALVE - SEAL SHOULD BE INTACT, AS RECEIVED. IF NOT, NOTIFY SUPPORT MAINTENANCE.

WE 66694

Figure 9-138.1. Adjustment - crew compartment and fixed (engine compartment) fire extinguisher control linkage (2 of 2)

TO CREW COMPARTMENT FIRE EXTINGUISHER VALVE (FIG. 9-139.1)

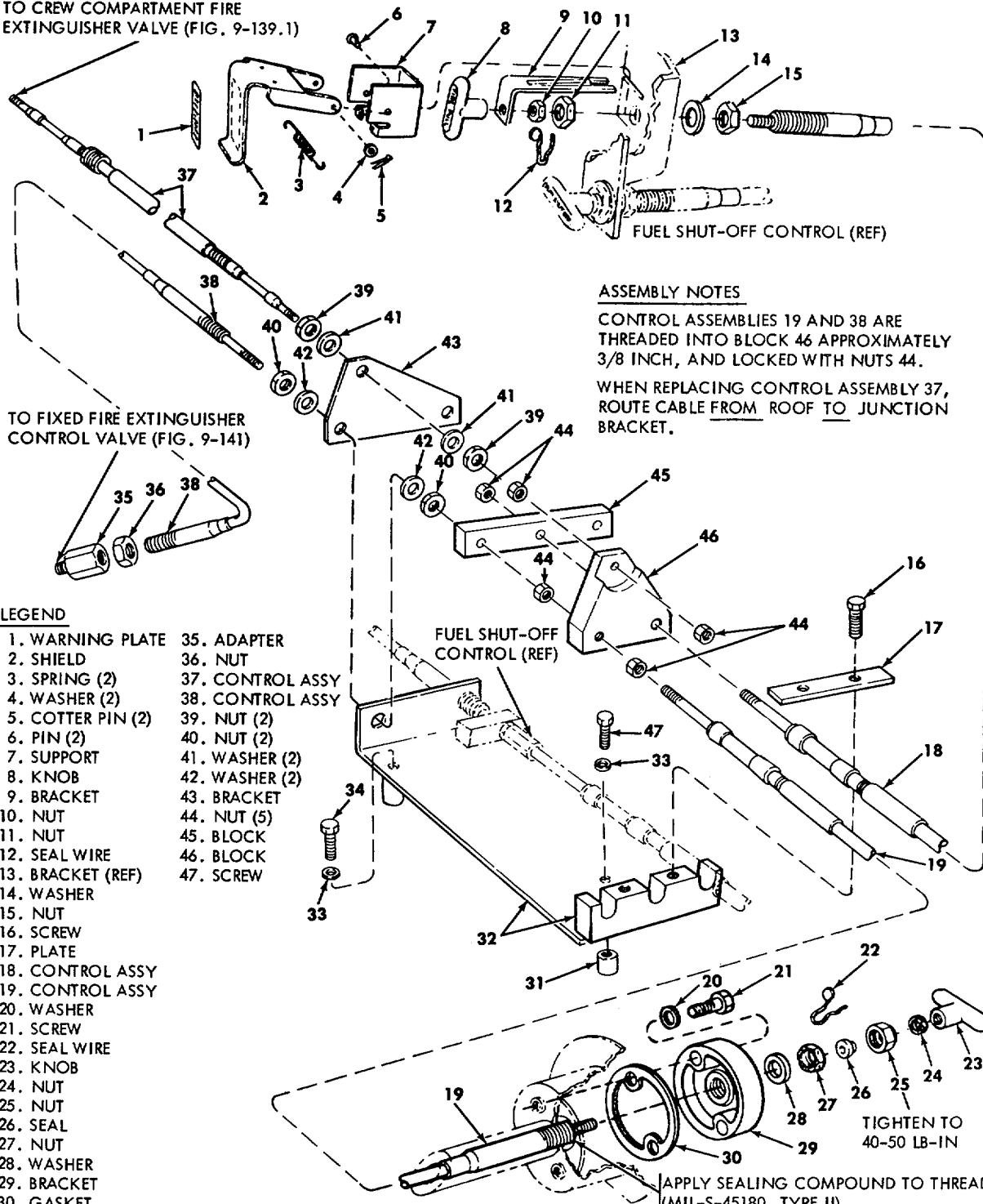

**ASSEMBLY NOTES**

CONTROL ASSEMBLIES 19 AND 38 ARE THREADED INTO BLOCK 46 APPROXIMATELY 3/8 INCH, AND LOCKED WITH NUTS 44.

WHEN REPLACING CONTROL ASSEMBLY 37, ROUTE CABLE FROM ROOF TO JUNCTION BRACKET.

**LEGEND**

- |                      |                  |
|----------------------|------------------|
| 1. WARNING PLATE     | 35. ADAPTER      |
| 2. SHIELD            | 36. NUT          |
| 3. SPRING (2)        | 37. CONTROL ASSY |
| 4. WASHER (2)        | 38. CONTROL ASSY |
| 5. COTTER PIN (2)    | 39. NUT (2)      |
| 6. PIN (2)           | 40. NUT (2)      |
| 7. SUPPORT           | 41. WASHER (2)   |
| 8. KNOB              | 42. WASHER (2)   |
| 9. BRACKET           | 43. BRACKET      |
| 10. NUT              | 44. NUT (5)      |
| 11. NUT              | 45. BLOCK        |
| 12. SEAL WIRE        | 46. BLOCK        |
| 13. BRACKET (REF)    | 47. SCREW        |
| 14. WASHER           |                  |
| 15. NUT              |                  |
| 16. SCREW            |                  |
| 17. PLATE            |                  |
| 18. CONTROL ASSY     |                  |
| 19. CONTROL ASSY     |                  |
| 20. WASHER           |                  |
| 21. SCREW            |                  |
| 22. SEAL WIRE        |                  |
| 23. KNOB             |                  |
| 24. NUT              |                  |
| 25. NUT              |                  |
| 26. SEAL             |                  |
| 27. NUT              |                  |
| 28. WASHER           |                  |
| 29. BRACKET          |                  |
| 30. GASKET           |                  |
| 31. SPACER           |                  |
| 32. JUNCTION BRACKET |                  |
| 33. WASHER (3)       |                  |
| 34. SCREW (2)        |                  |

REPLACE UNSERVICEABLE PARTS AS REQUIRED.

THREAD SEAL WIRE THROUGH NUTS (INTERIOR KNOB: 10 AND 11. EXTERIOR KNOB: 24 AND 27) AND THROUGH HOLE IN LEAD SEAL. ALLOW 1/2 TO 3/4 INCH SLACK, CRIMP SEAL, AND CUT OFF EXCESS WIRE.

WE 66686

Figure 9-139. Disassembly/assembly - crew compartment and fixed (engine compartment) fire extinguisher control systems (1 of 2)



LEGEND

1. ELECTRICAL CONNECTOR
2. CYLINDER AND VALVE ASSY
3. PIN
4. COTTER PIN
5. PLATE (2)
6. CLAMP (2)
7. WASHER (4)
8. SOLENOID GROUND LEAD
9. WASHER
10. SCREW (4)
11. CONTROL ASSY
12. NOZZLE ASSY
13. NUT
14. CLAMP
15. SCREW (2)
16. WASHER (2)
17. NUT
18. CLAMP (3)
19. SUPPORT
20. WASHER (2)
21. WASHER (3)
22. SCREW (3)
24. WASHER
25. WASHER (2)
26. SUPPORT
27. NUT
28. CLEVIS

**WARNING:** NOZZLE (12) MUST BE DISCONNECTED AND CAP INSTALLED BEFORE CYLINDER MOUNTING SCREWS (10) ARE LOOSENED.

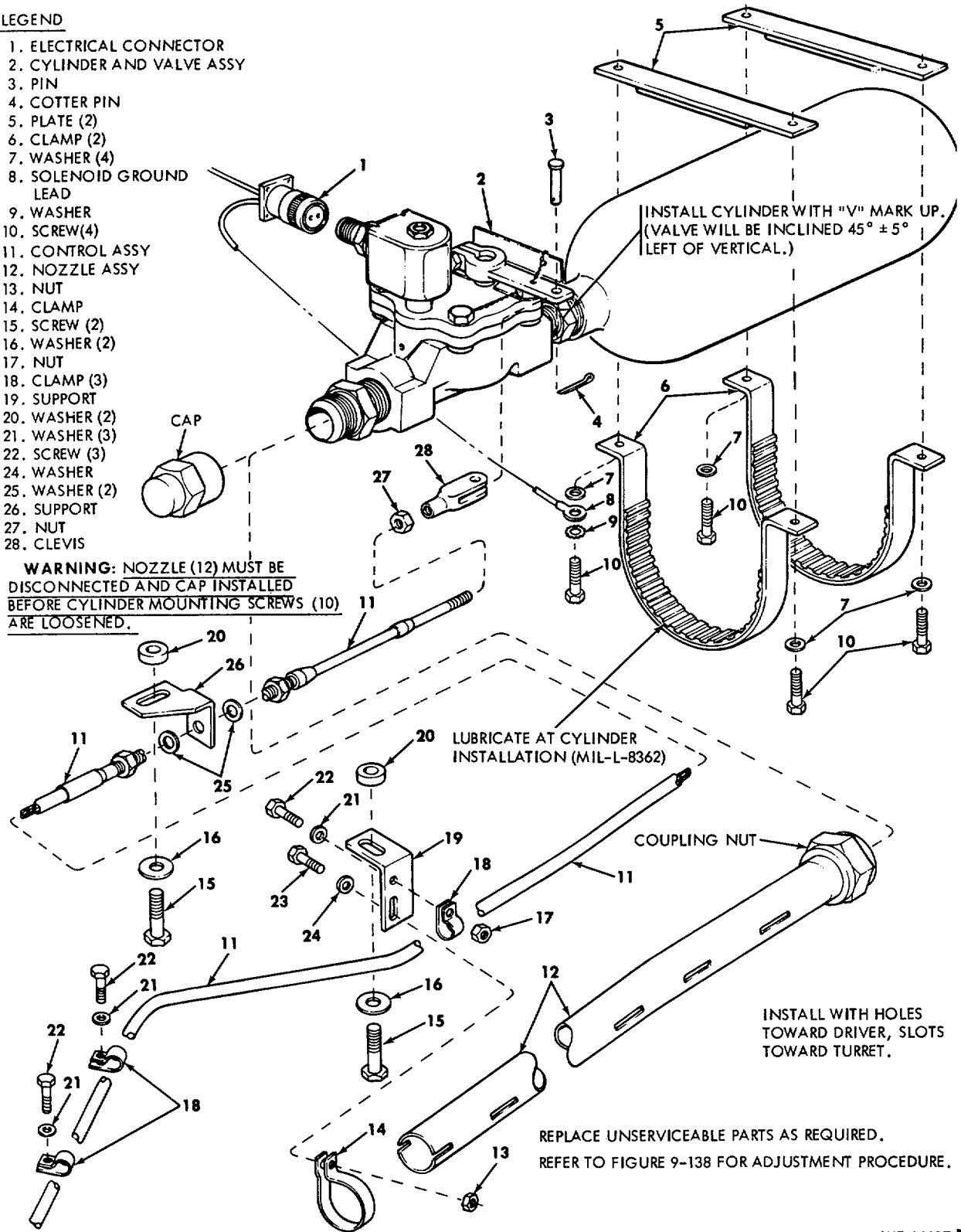
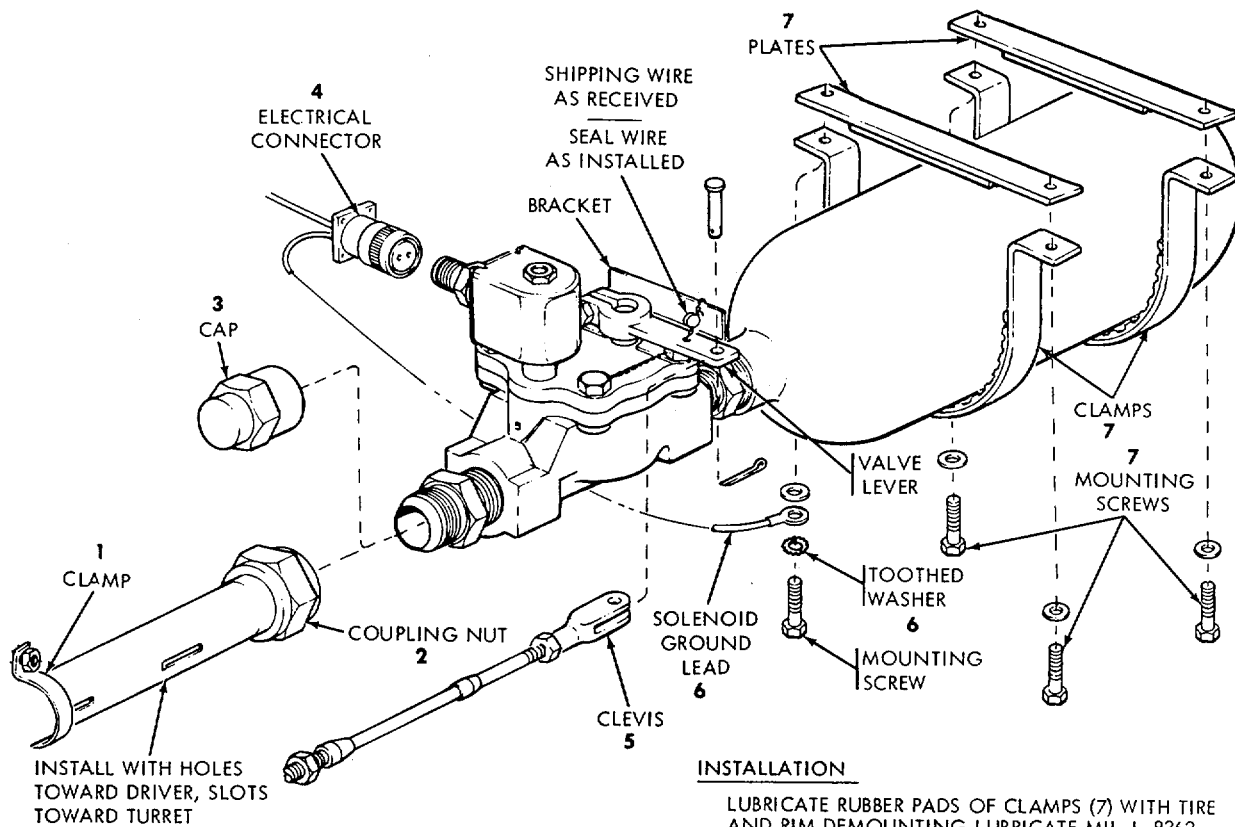

Figure 9-139.1. Disassembly/assembly - crew compartment and fixed (engine compartment) fire extinguisher control systems (2 of 2)

WE 66687



**WARNING:** NOZZLE MUST BE DISCONNECTED AND CAP INSTALLED BEFORE CYLINDER MOUNTING SCREWS ARE LOOSENED.

#### REMOVAL

1. LOOSEN OR REMOVE CLAMP
2. DISCONNECT NOZZLE COUPLING NUT
3. INSTALL CAP ON VALVE
4. DISCONNECT ELECTRICAL CONNECTOR
5. DISCONNECT CLEVIS FROM VALVE LEVER BY REMOVING COTTER PIN AND PIN
6. DISCONNECT SOLENOID GROUND LEAD BY REMOVING MOUNTING SCREW, TOOTHED WASHER AND FLAT WASHER
7. REMOVE CYLINDER AND VALVE ASSEMBLY, WITH CYLINDER CLAMPS AND PLATES, BY REMOVING THE OTHER THREE MOUNTING SCREWS AND WASHERS.

**CAUTION:** DO NOT LIFT CYLINDER AND VALVE ASSEMBLY BY THE SOLENOID, OR SHAFT WILL BE DISTORTED AND VALVE WILL NOT OPERATE.

#### INSTALLATION

LUBRICATE RUBBER PADS OF CLAMPS (7) WITH TIRE AND RIM DEMOUNTING LUBRICATE MIL-L-8362. DO NOT SUBSTITUTE ANY OTHER LUBRICATE.

INSTALL PLATES (7), CYLINDER CLAMPS (7), SOLENOID GROUND LEAD (6), TOOTHED WASHER (6), MOUNTING SCREWS (7), AND WASHERS (7). TIGHTEN SCREWS ONLY ENOUGH TO SUPPORT CYLINDER WEIGHT (3 OR 4 THREADS ENGAGED).

INSTALL CYLINDER AND VALVE ASSEMBLY WITH "V" MARK UP. (VALVE WILL BE INCLINED  $45^\circ \pm 5^\circ$  LEFT OF VERTICAL.) POSITION CYLINDER HORIZONTALLY SO HOLE IN VALVE LEVER APPROXIMATELY ALIGNS WITH CLEVIS, AND TIGHTEN MOUNTING SCREWS.

CONNECT CLEVIS (5) TO VALVE LEVER WITH PIN AND COTTER PIN. (LOOSEN JAM NUT AND ADJUST CLEVIS IF NECESSARY).

CONNECT ELECTRICAL CONNECTOR (4) TO SOLENOID VALVE.

REMOVE AND STOW CAP (3), AND CONNECT NOZZLE ASSEMBLY WITH HOLES AND SLOTS ORIENTED AS SHOWN ON DRAWING. TIGHTEN COUPLING NUT (2) AND CLAMP (1).

REFER TO FIGURE 9-138 IF ADJUSTMENT IS REQUIRED.

REPLACE SHIPPING WIRE ON VALVE LEVER WITH SEAL WIRE. THREAD WIRE THROUGH HOLES IN LEVER, BRACKET, AND LEAD SEAL. PULL WIRE SNUG, BUT NOT UNDER TENSION, AND CRIMP LEAD SEAL.

WE 66688

Figure 9-139.2. Removal/installation - crew compartment fire extinguisher cylinder

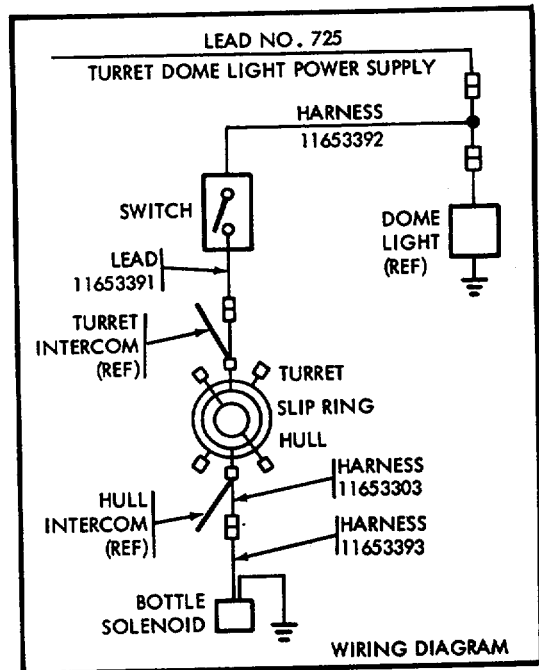
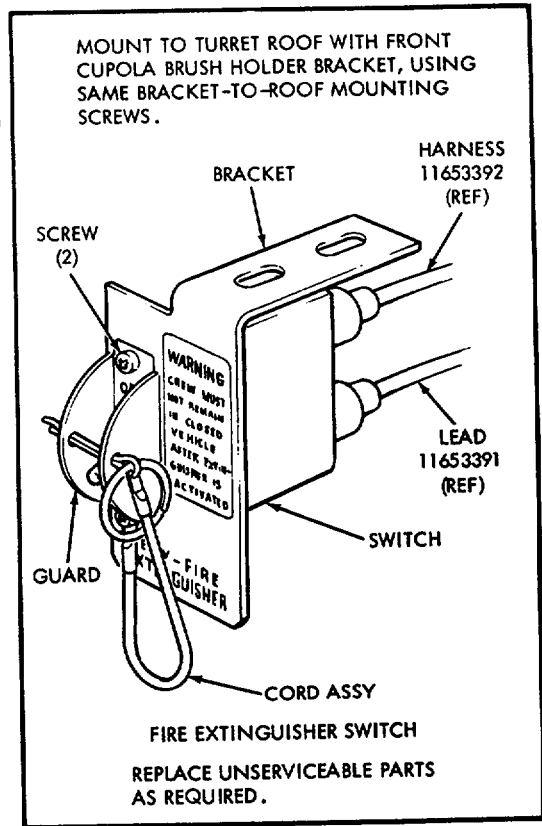
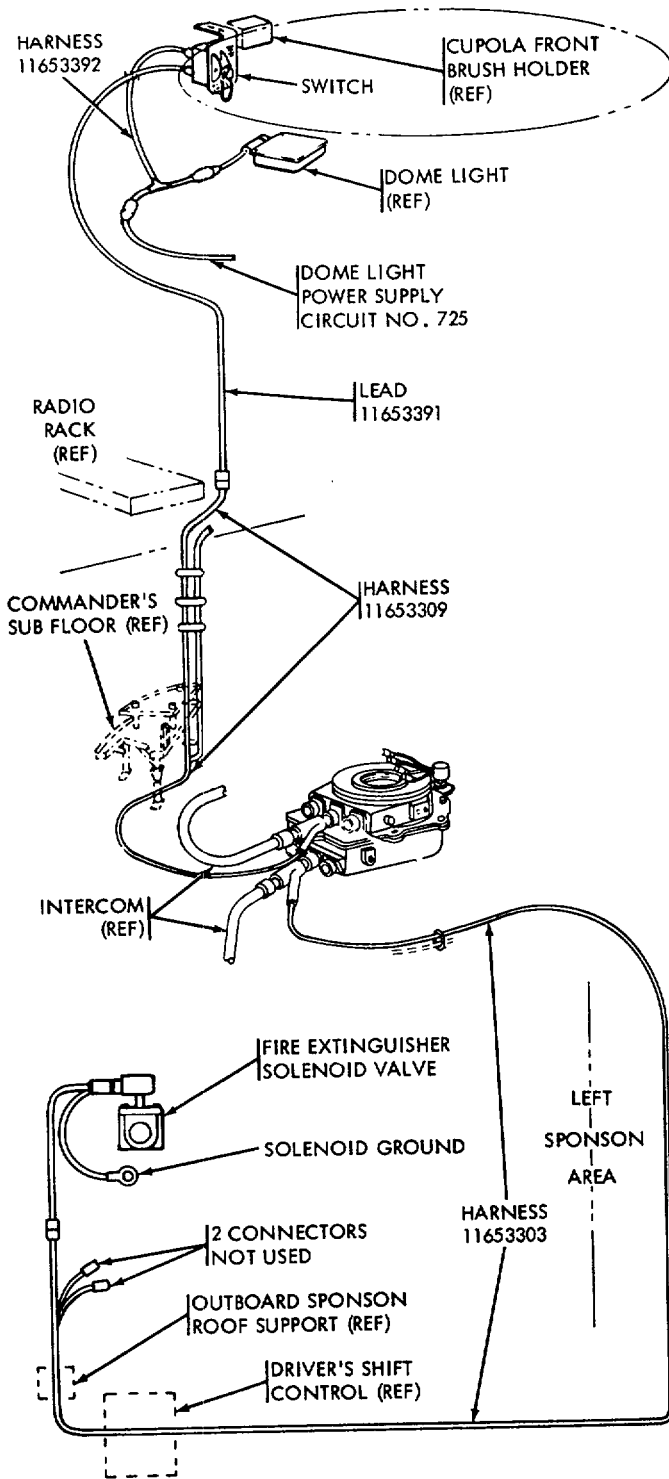

WE 66689

Figure 9-139.3. Crew compartment fire extinguisher wiring harness location reference, wiring diagram, and repair of switch assembly

FOR LOCATION AND IDENTIFICATION OF TURRET  
HARNESSES AND LEAD, SEE FIGURE 9-139.3.

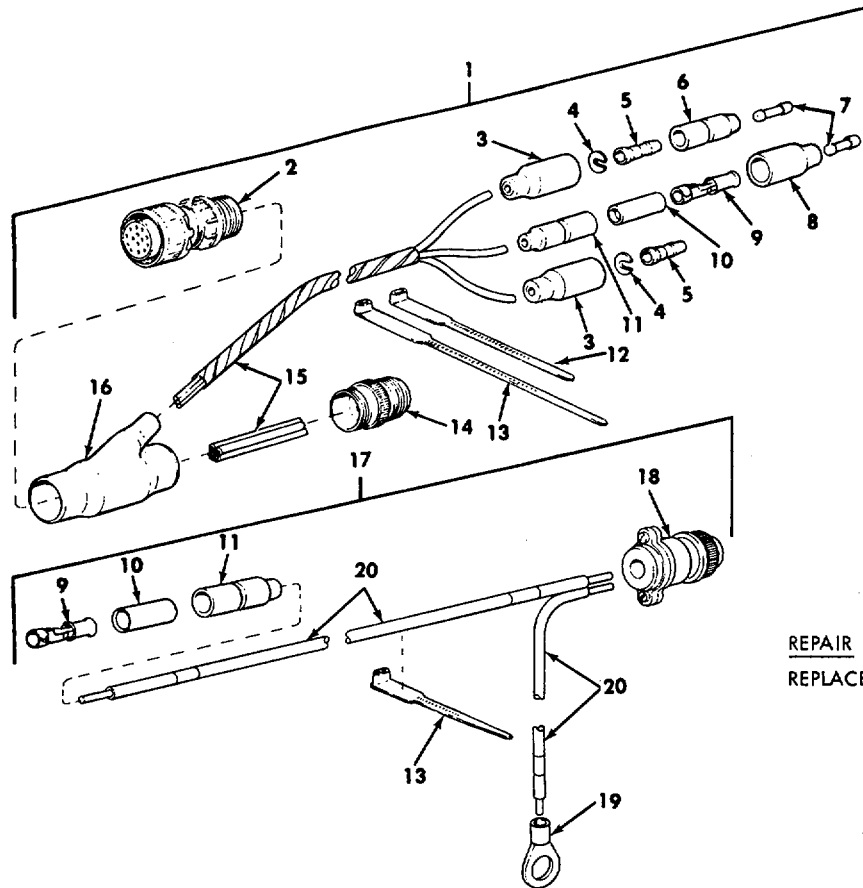

LEGEND

1. WIRING HARNESS 11653303
2. CONNECTOR
3. SHELL (2)
4. WASHER (2)
5. CONTACT (TERMINAL) (2)
6. SHELL
7. PLUG (2)
8. SHELL
9. TERMINAL (2)
10. SLEEVE INSULATOR (2)
11. SHELL (NIPPLE) (2)
12. STRAP (2)
13. STRAP
14. CONNECTOR
15. CABLE GROUP
16. NIPPLE
17. WIRING HARNESS 11653393
18. CONNECTOR
19. LUG TERMINAL
20. CABLE GROUP

REPAIR

REPLACE UNSERVICEABLE PARTS AS REQUIRED.

WE 66690

Figure 9-139.4. Repair - crew compartment fire extinguisher hull wiring harnesses

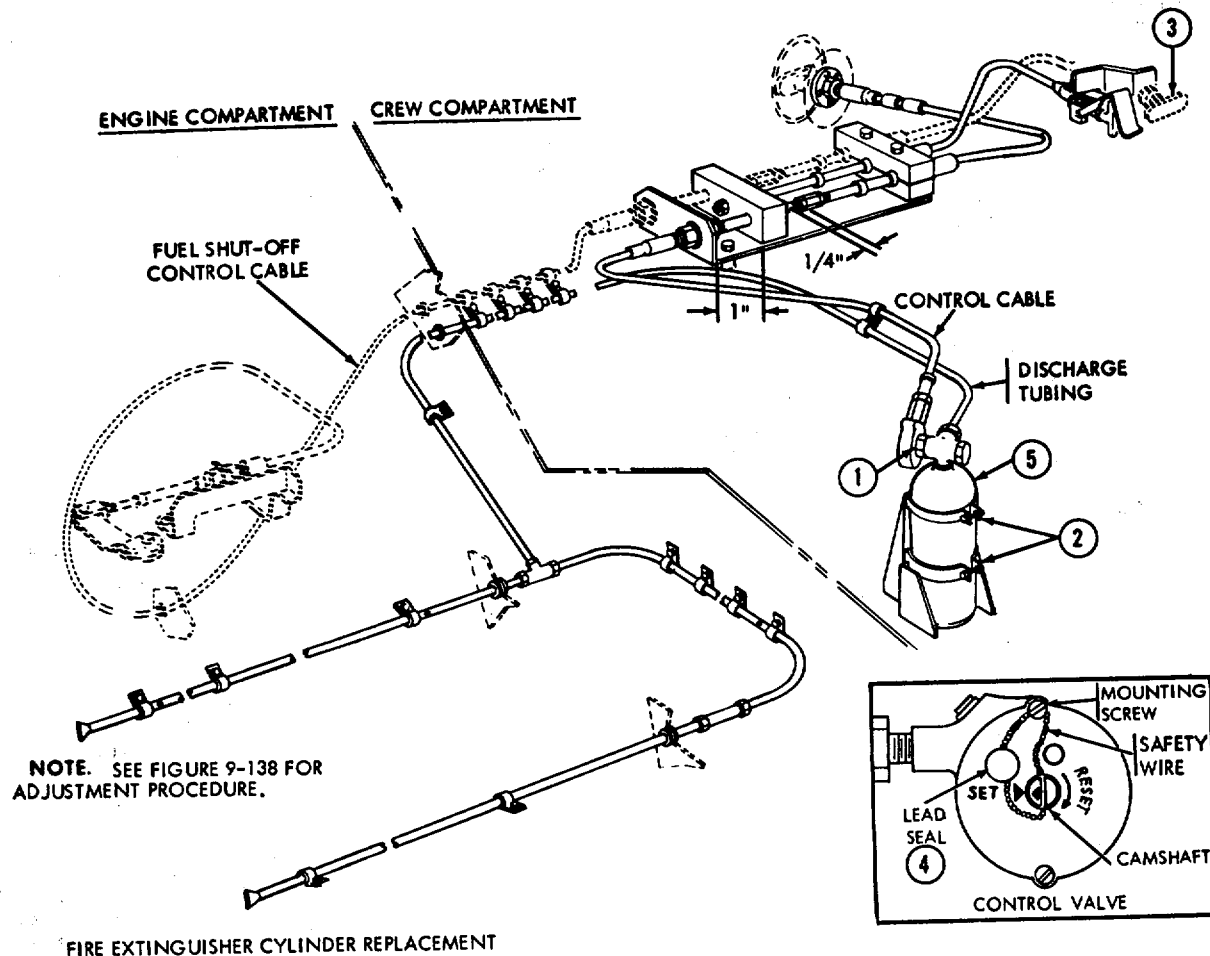

**FIRE EXTINGUISHER CYLINDER REPLACEMENT**

1. LOOSEN SWIVEL NUT AT JUNCTION OF CONTROL VALVE AND FLOOD VALVE AND DISCONNECT CONTROL VALVE.
2. DISCONNECT 2 CYLINDER CLAMPS AND DISCHARGE TUBING AT FLOOD VALVE AND REMOVE FIRE EXTINGUISHER CYLINDER.
3. FULLY DEPRESS INTERNAL AND EXTERNAL FIRE EXTINGUISHER KNOBS.
4. REMOVE BROKEN SAFETY WIRE ON CONTROL VALVE AND ALIGN ARROW ON CAMSHAFT WITH "SET" ARROW (SEE INSET). INSTALL SAFETY WIRE (FIG. 9-142).
5. INSTALL FIRE EXTINGUISHER CYLINDER, CONNECT DISCHARGE LINE, 2 CYLINDER CLAMPS, AND CONTROL VALVE.

WE 66693

Figure 9-140. Fixed fire extinguisher cylinder replacement

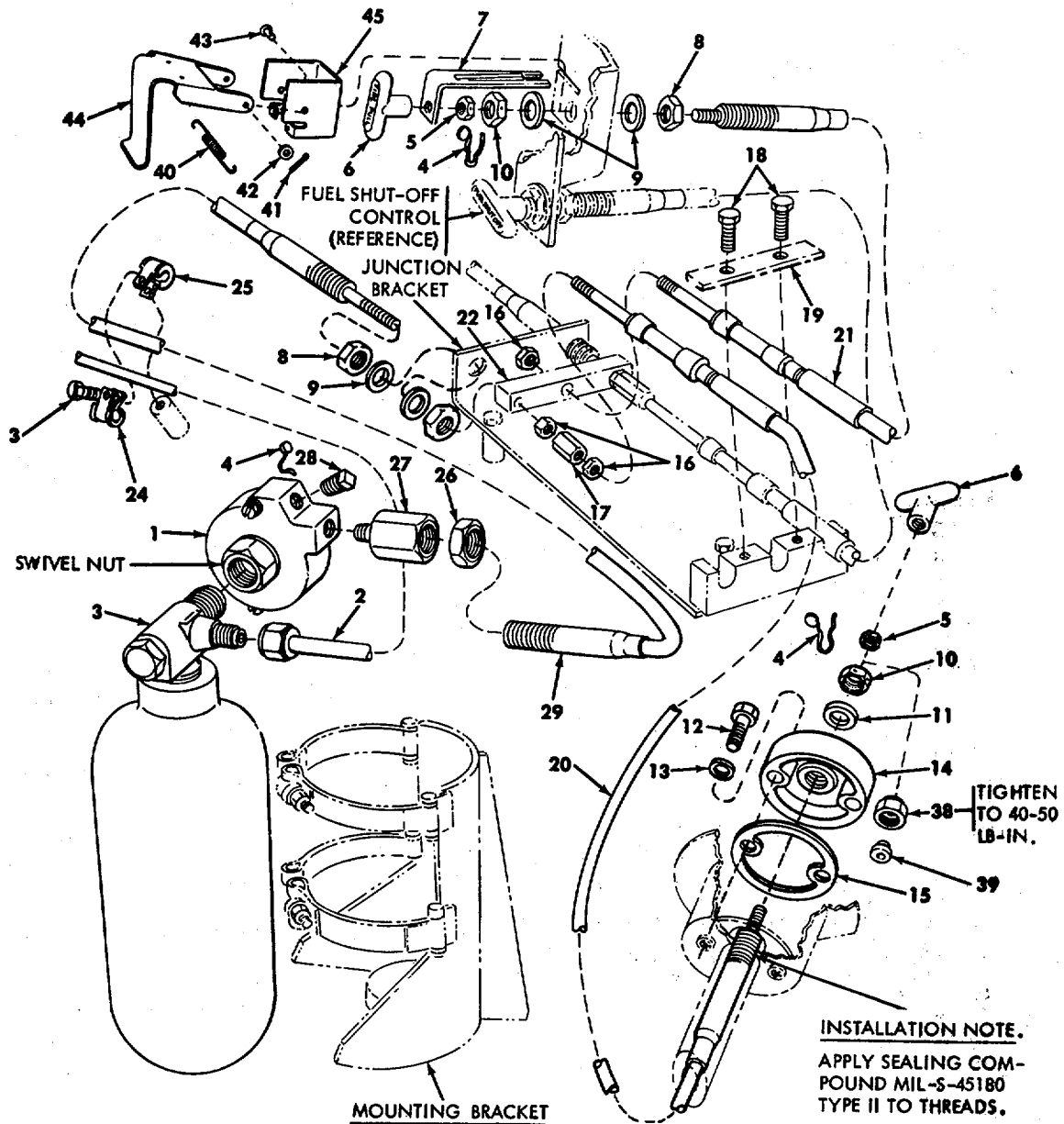
CREW COMPARTMENTPRELIMINARY STEPS

- A. OPEN ENGINE EXHAUST LEFT GRILLE AND REMOVE ENGINE AIR INLET GRILLE.
- B. DISCONNECT CONTROL VALVE (1), BY LOOSENING SWIVEL NUT. THIS MUST BE ACCOMPLISHED PRIOR TO WORKING ON CONTROL LINKAGE.

REMOVAL

1. REFER TO TABLE 9-9.1 FOR CONTROL CABLE HANDLING PRECAUTIONS.
2. REFER TO FIGURE 9-42 FOR LOCATIONAL REFERENCE.
3. REFER TO FIGURE 9-142 FOR LEGEND.

WE 66691

Figure 9-141. Removal/installation/repair - fixed fire extinguisher control system (1 of 2)

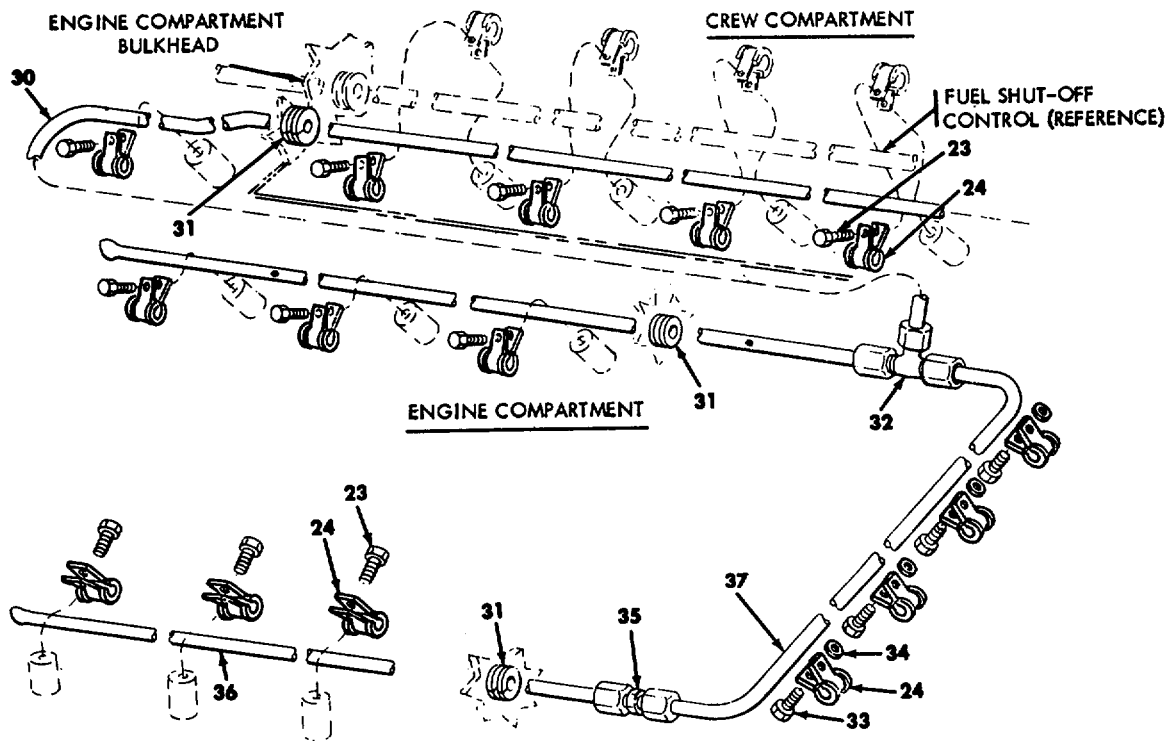

**LEGEND**

- 1. CONTROL VALVE
- 2. NUT, TUBING
- 3. CYLINDER
- 4. SAFETY WIRE, SEAL (3)  
**NOTE. SEE INSTALLATION INSTRUCTIONS BELOW.**
- 5. NUT (2)
- 6. KNOB (2)
- 7. BRACKET
- 8. JAM NUT (4)
- 9. WASHER (4)
- 10. JAM NUT (2)
- 11. WASHER
- 12. SCREW (2)
- 13. WASHER (2)
- 14. BRACKET
- 15. GASKET
- 16. JAM NUT (3)

- 17. NUT COUPLING
- 18. SCREW (2)
- 19. CLAMPING PLATE
- 20. INTERNAL CONTROL CABLE
- 21. EXTERNAL CONTROL CABLE
- 22. JUNCTION BLOCK
- 23. SCREW (12)
- 24. CLAMP (16)
- 25. CLAMP
- 26. NUT
- 27. ADAPTER
- 28. PIPE PLUG
- 29. CONTROL CABLE
- 30. TUBE
- 31. GROMMET (3)
- 32. TUBING TEE ASSEMBLY
- 33. SCREW (4)
- 34. WASHER (4)
- 35. TUBING UNION ASSEMBLY

- 36. TUBE (2)
- 37. TUBE
- 38. SEAL NUT - 5310-821-4533
- 39. SEAL - 2540-077-1949
- 40. SPRING (2) - 5340-089-9788
- 41. COTTER PIN (2) - 5315-839-2325
- 42. WASHER (2) - 5310-809-8546
- 43. PIN (2) - MS20392-2C7
- 44. SHIELD - 2510-877-8958
- 45. SUPPORT - 2510-877-8959

**INSTALLATION**

REPLACE UNSERVICEABLE ITEMS AS REQUIRED. ITEM 6 (EXTERIOR AND INTERIOR KNOBS): THREAD SAFETY WIRE THROUGH NUT (10), THEN NUT (5) AND HOLE IN LEAD SEAL. ALLOW 1/2 TO 3/4 INCH SLACK IN WIRE, CRIMP SEAL, AND CUT OFF EXCESS WIRE.

**CONTROL VALVE SAFETY WIRE (SEE INSET, FIG. 9-140):**

1. ALIGN ARROWHEAD ON RESET CAMSHAFT TO "SET".
2. THREAD SAFETY WIRE THROUGH MOUNTING SCREW, THEN THROUGH CAMSHAFT AND LEAD SEAL.
3. DRAW WIRE TIGHT AND CRIMP SEAL. CUT OFF EXCESS WIRE.

**NOTE.** ADJUST LINKAGE AFTER INSTALLATION (FIG. 9-138). REFER TO FIGURE 9-22 FOR FUEL SHUT-OFF ADJUSTMENT.

WE 66692

Figure 9-142. Removal/installation/repair - fixed fire extinguisher control system (2 of 2)

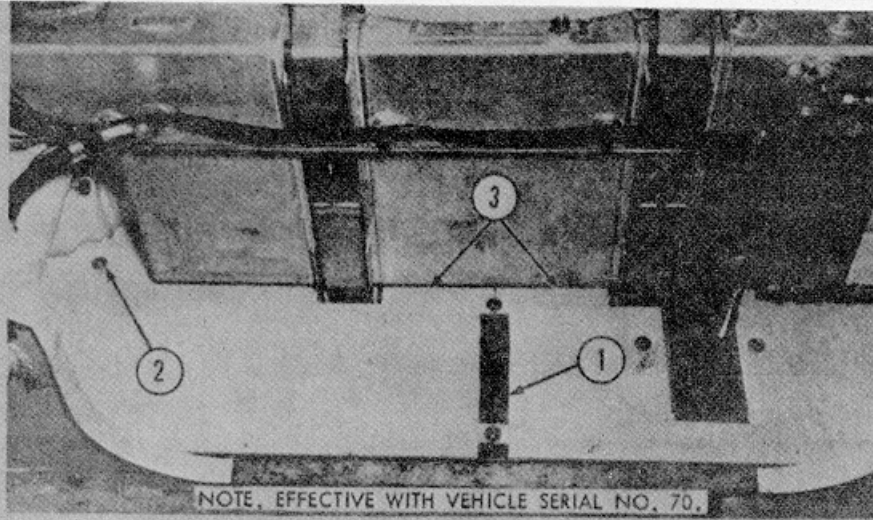

NOTE, EFFECTIVE WITH VEHICLE SERIAL NO. 70.

REMOVAL - CONTAMINATION SHIELD

1. TAPE
2. SCREWS (8) AND WASHERS (8).
3. SHIELD (2 PIECES)

INSTALLATION

REVERSE REMOVAL PROCEDURE, USE OD PRESSURE-SENSITIVE ADHESIVE TAPE ON CENTER JOINT.

NOTE. WHEN REPLACING RUBBER SEAL, MAKE SURE MOUNTING SURFACES ARE FREE OF DIRT AND PAINT. COAT MOUNTING SURFACES WITH ADHESIVE - 8040-664-4318. REFER TO PARAGRAPH 8-6.

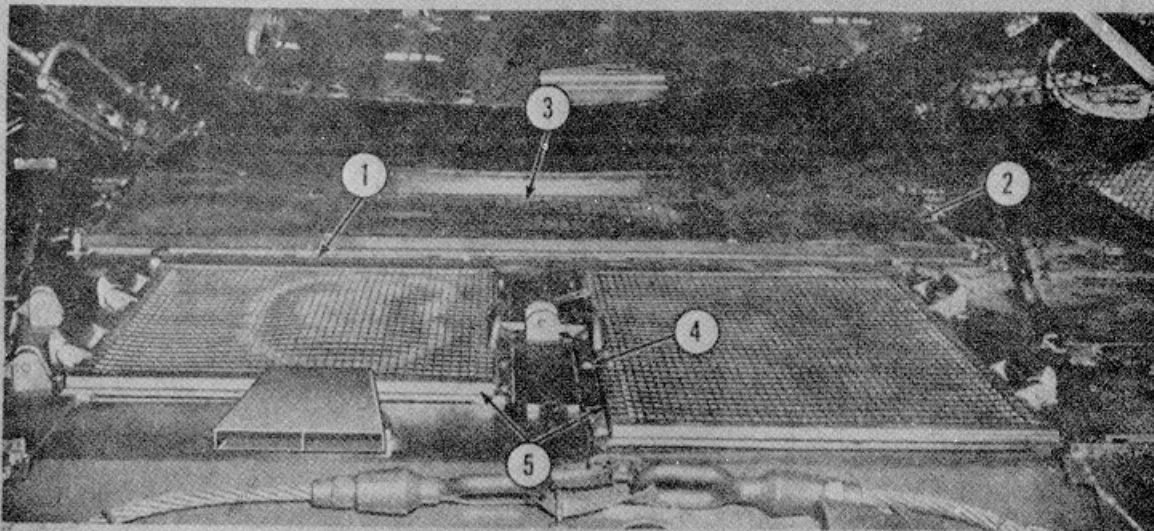

LEGEND

- |  |   |
|--|---|
| <ol style="list-style-type: none"> <li>1. SCREWS (7)</li> <li>2. SCREWS (6), WASHERS (6), AND SPACERS (6).</li> <li>3. INTAKE GRILLE DEBRIS SCREEN.</li> </ol> | <ol style="list-style-type: none"> <li>4. SCREWS (16) AND WASHERS (16).</li> <li>5. EXHAUST GRILLE DEBRIS SCREENS (2).</li> </ol> |
|--|---|

INSTALLATION NOTE. TIGHTEN SCREWS (ITEM 2) TO 90 POUNDS-FEET.

REMOVAL/INSTALLATION

REPLACE UNSERVICEABLE COMPONENTS AS REQUIRED.

TA007338

Figure 9-142.1. Removal/Installation - radiator contamination shield and grille debris screens



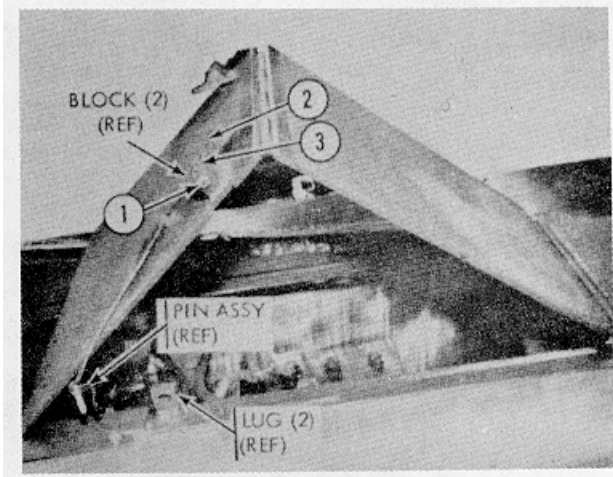
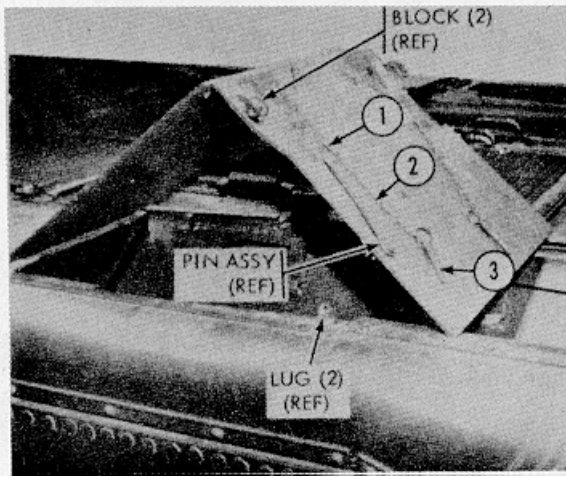

LEGEND

VEHICLES SN 1 THROUGH 1292

- 1. S-HOOK (4)
- 2. CHAIN (2)
- 3. PIN ASSEMBLY (2)

LEGEND

EFFECTIVE VEHICLE SN 1293 0

- 1. PIN (2)
- 2. PIN k2
- 3. CLIP (2)

REPLACE UNSERVICEABLE COMPONENTS AS REQUIRED,

Figure 9-142.2. Repair - battery and air cleaner access doors

WE 12197

9-146.2

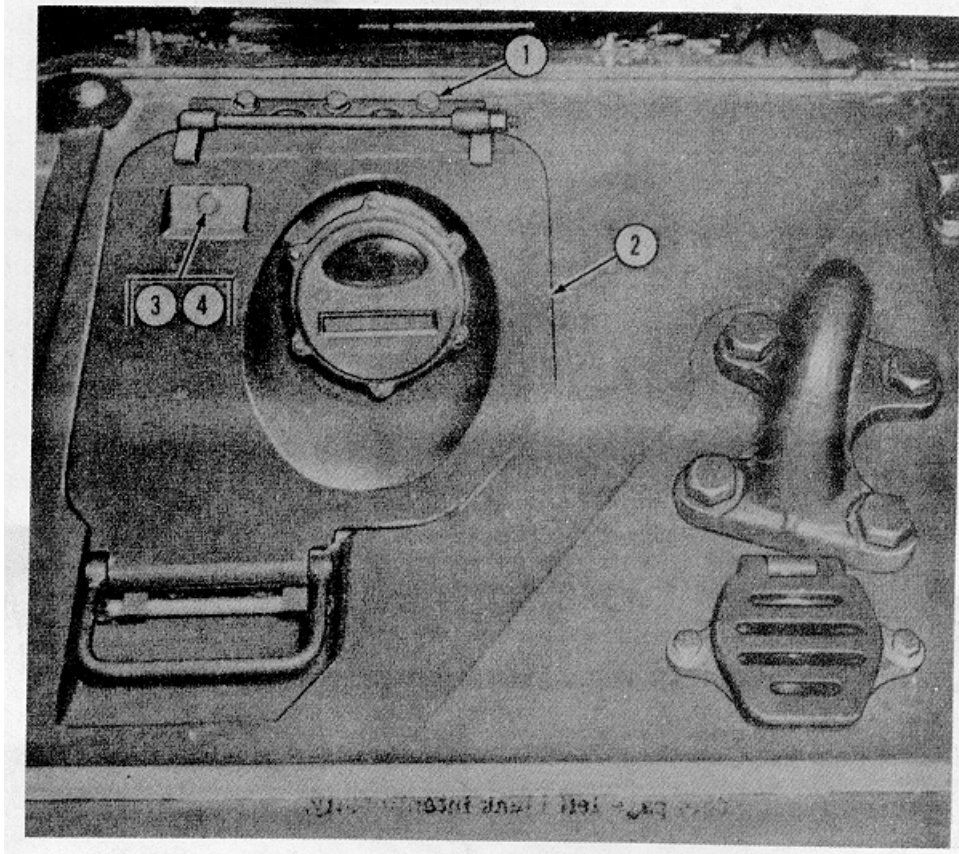
**LEGEND**

1. SCREW (3)
2. DOOR ASSEMBLY (SHOWN WITH TAILLIGHT)
3. INDICATOR LIGHT JEWEL HOLDER ASSEMBLY
4. INDICATOR LIGHT LAMP

**PRELIMINARY STEP**

TURN MASTER SWITCH TO "OFF" POSITION. OPEN INTERCOM DOOR, DISCONNECT ELECTRICAL LEADS (INDICATOR LIGHT TO INTERCOM BOX AND TAILLIGHT TO WIRING HARNESS).

**REMOVAL**

REMOVE BY FOLLOWING NUMERICAL SEQUENCE.

NOTE: DOOR ASSEMBLY MAY BE REMOVED FROM VEHICLE WITHOUT REMOVING INDICATOR LAMP OR TAILLIGHT.

**INSTALLATION**

REVERSE REMOVAL PROCEDURE

- NOTE: 1. WHEN ATTACHING HINGE BRACKET, CLEAN HULL MOUNTING FACES AND APPLY SEALER PER MIL S-22473 GRADE B.
2. TO ADJUST SPRING COMPRESSION ON HINGE, TIGHTEN HINGE NUT INCREASING SPRING COMPRESSION UNTIL DOOR IS MAINTAINED IN OPEN POSITION.

**WE 1043**

*Figure 9-143. Disassembly/assembly -,ground intercom box door assembly and components  
(1 of 2)*

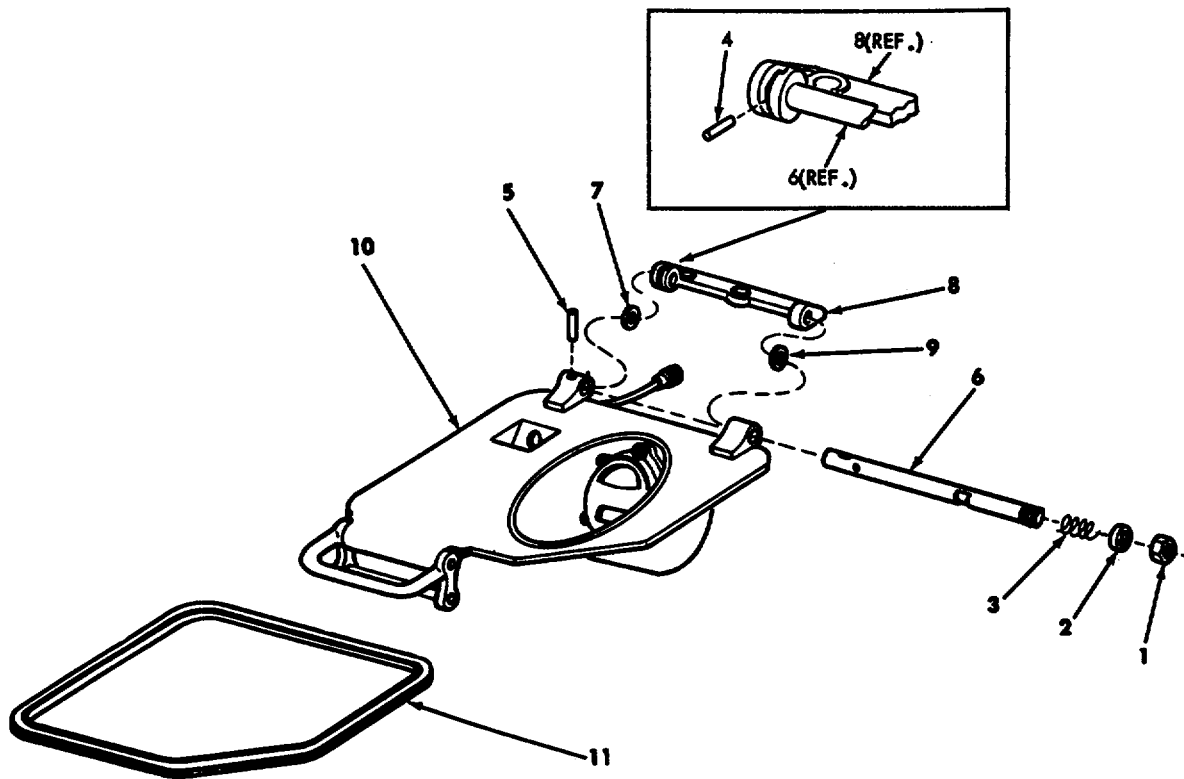

**LEGEND**

- 1. HINGE NUT
- 2. HINGE PIN SPACER
- 3. HINGE PIN COMPRESSION SPRING
- 4. DOWEL PIN
- 5. DOWEL PIN
- 6. HINGE PIN
- 7. WASHER
- 8. BRACKET
- 9. WASHER
- 10. DOOR (WITH TAILLIGHT)
- 11. DOOR SEAL

**DISASSEMBLY**

DISASSEMBLE FOLLOWING NUMERICAL SEQUENCE.

**ASSEMBLY**

REVERSE DISASSEMBLY PROCEDURE.

NOTE. WHEN REPLACING DOOR SEAL. REFER TO PARAGRAPH 8-6, APPLYING ADHESIVE 8040-664-4318.

WE 11044

Figure 9-144. Disassembly/assembly - ground intercom box door assembly and components  
(2 of 2)

Figure 9-144. 1-deleted.

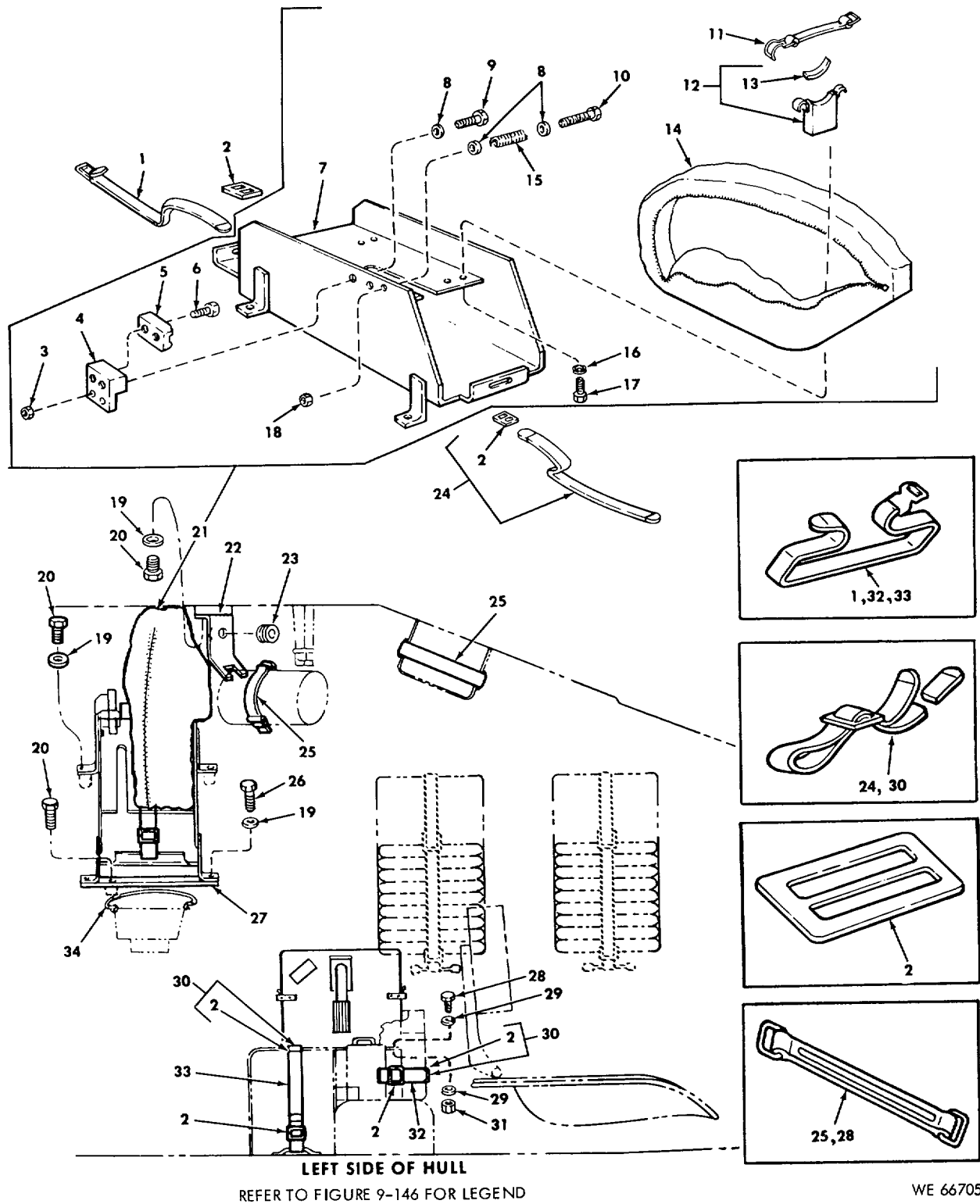
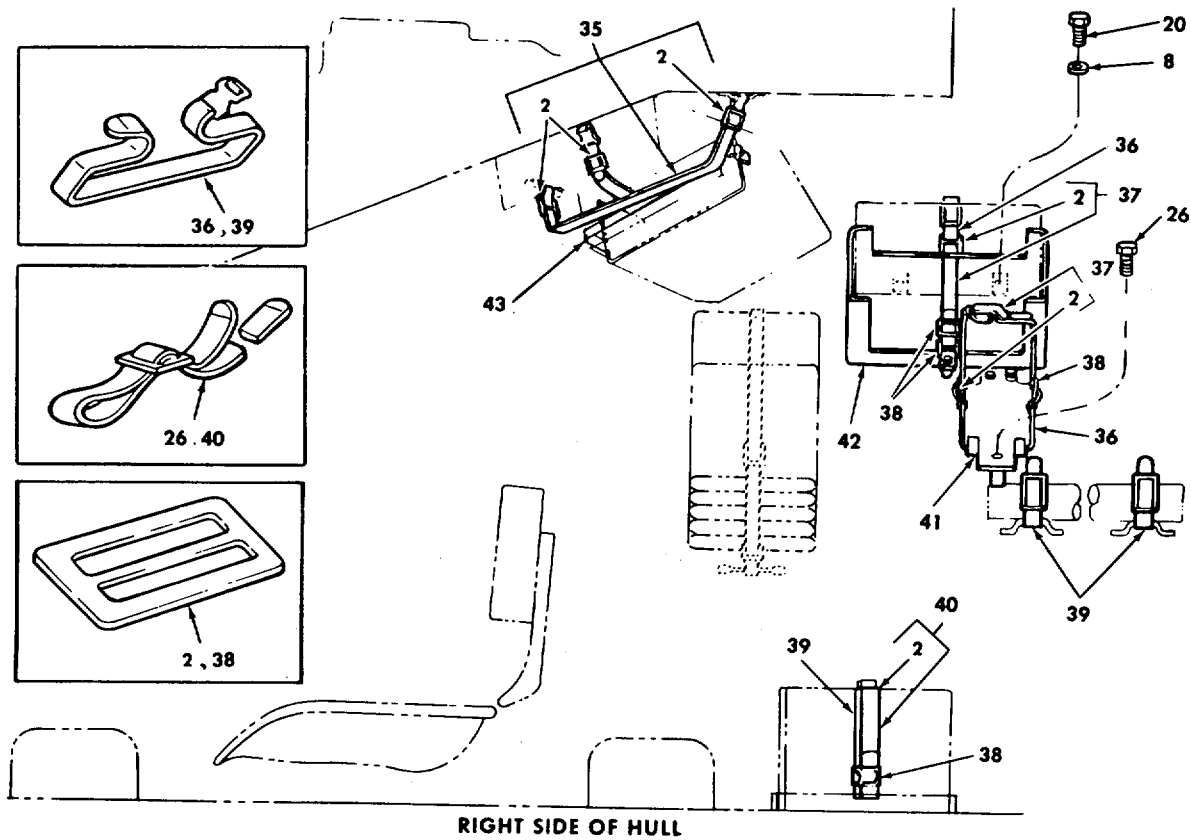

Figure 9-145. Hull interior stowage (1 of 3)

9-148.2/(9-148.1 Blank)



LEGEND FOR FIGURES 9-145 AND 9-146

- |                           |                    |
|---------------------------|--------------------|
| 1. STRAP                  | 23. GROMMET        |
| 2. BUCKLE ( 11 )          | 24. STRAP          |
| 3. NUT ( 2 )              | 25. BAND ( 2 )     |
| 4. SUPPORT                | 26. SCREW ( 3 )    |
| 5. HOLDER                 | 27. SPACER         |
| 6. SCREW ( 2 )            | 28. SCREW ( 3 )    |
| 7. BRACKET                | 29. WASHER ( 6 )   |
| 8. WASHER ( 7 )           | 30. STRAP ( 2 )    |
| 9. SCREW ( 2 )            | 31. NUT ( 3 )      |
| 10. SCREW                 | 32. STRAP          |
| 11. BAND ASSEMBLY ( 2 )   | 33. STRAP          |
| 12. CRADLE ASSEMBLY ( 2 ) | 34. BAND           |
| 13. PAD ( 2 )             | 35. STRAP ASSEMBLY |
| 14. COVER ASSEMBLY        | 36. STRAP ( 3 )    |
| 15. SPRING                | 37. STRAP ( 2 )    |
| 16. WASHER ( 4 )          | 38. BUCKLE ( 4 )   |
| 17. SCREW ( 4 )           | 39. STRAP ( 3 )    |
| 18. NUT                   | 40. STRAP          |
| 19. WASHER ( 7 )          | 41. BRACKET        |
| 20. SCREW ( 10 )          | 42. BRACKET        |
| 21. STOWAGE RACK          | 43. BAND           |
| 22. BRACKET               |                    |

WE 66706

Figure 9-146. Hull interior stowage (2 of 3)

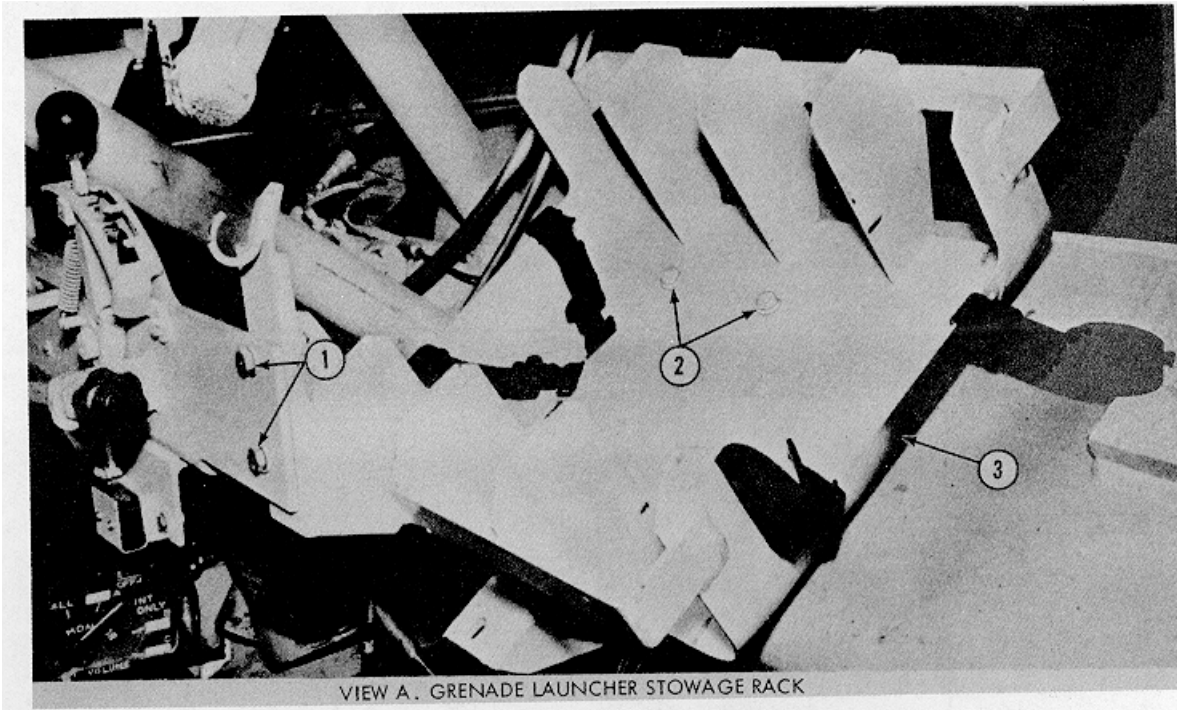

VIEW A. GRENADE LAUNCHER STOWAGE RACK

PRELIMINARY STEP

LATCH DRIVER'S HATCH IN OPEN POSITION AND REMOVE ALL GRENADE LAUNCHERS FROM RACK.

NOTE. VIEW A IS APPLICABLE ONLY TO VEHICLES LESS MISSILE CAPABILITY.

REMOVAL

1. SCREWS (2), WASHERS (4), AND NUTS (2).
2. FOUR SCREWS AND WASHERS.
3. GRENADE LAUNCHER RACK ASSEMBLY.

INSTALLATION

REVERSE REMOVAL PROCEDURE. REPLACE STRAPS IF WORN OR DAMAGED.

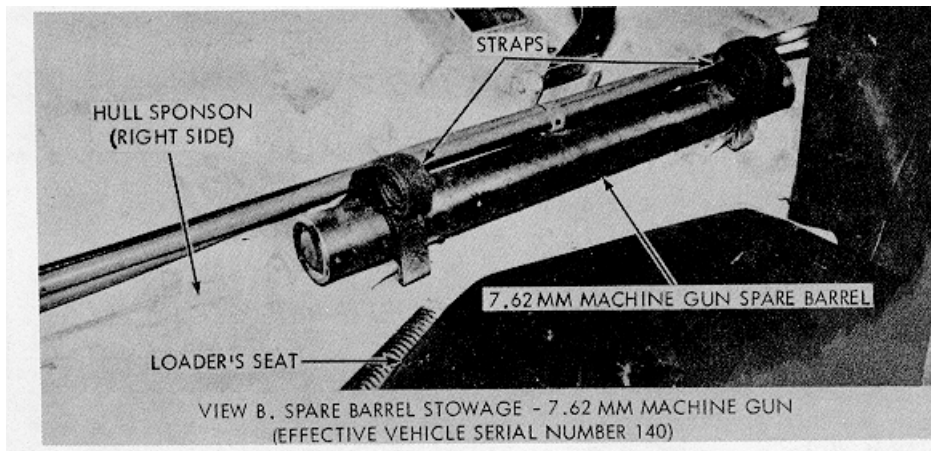

WE 66708

REMOVAL INSTALLATION

POSITION TURRET WITH GUN-LAUNCHER OVER REAR OF VEHICLE. REMOVE CLIPS AND LOADER'S PROTECTIVE SCREEN TO GAIN ACCESS TO 7.62MM MACHINE GUN SPARE BARREL. REPLACE WORN OR DAMAGED STRAPS. WE 66708

*Figure 9-146.1. Hull interior stowage (3 of 3)*

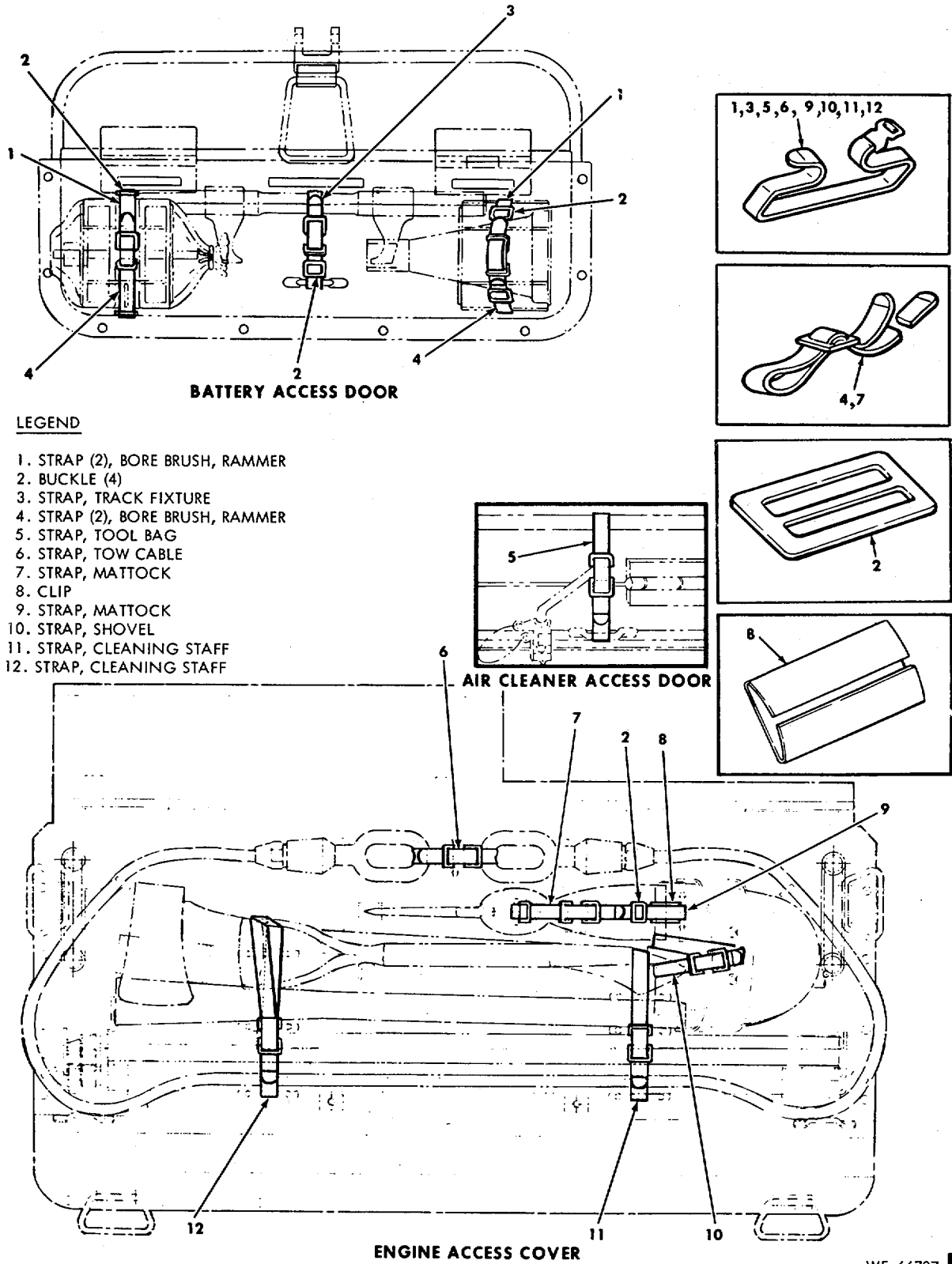

Figure 9-147. Hull exterior stowage



NOTE. REPAIR KIT 2910-078-4065 CONTAINS NECESSARY MATERIAL TO MAKE THE FOLLOWING REPAIRS.  
DO NOT ATTEMPT REPAIRS IN TEMPERATURES BELOW 70°F.

#### PREPARING FLOTATION SKIN SURFACE (VIEW A)

CLEAN SURFACE AROUND HOLE TO BARE METAL WITH WIRE BRUSH OR COARSE SAND PAPER. TRIM AWAY ALL RAGGED EDGES AND PEEN EDGES OF SKIN SLIGHTLY TOWARD FOAM TO FORM A SLIGHT DEPRESSION. CLEAN SURFACE WITH NAPHTHA OR PAINT THINNER FOLLOWED BY DENATURATED ALCOHOL.

#### REPAIR OF HOLES UP TO 2 INCHES IN DIAMETER

1. PREPARE SKIN SURFACE (ABOVE) AND CUT GLASS CLOTH PATCH SLIGHTLY LARGER THAN HOLE (VIEW A).
2. PREPARE RESIN AND HARDENER (IN REPAIR KIT).
3. SATURATE CLOTH PATCH WITH MIXTURE AND FORM OVER DAMAGED AREA. SUCCESSIVE PATCHES OF SLIGHTLY LARGER DIAMETER MAY BE ADDED TO BRING PATCHED SURFACE SLIGHTLY ABOVE THAT OF FLOTATION SKIN.

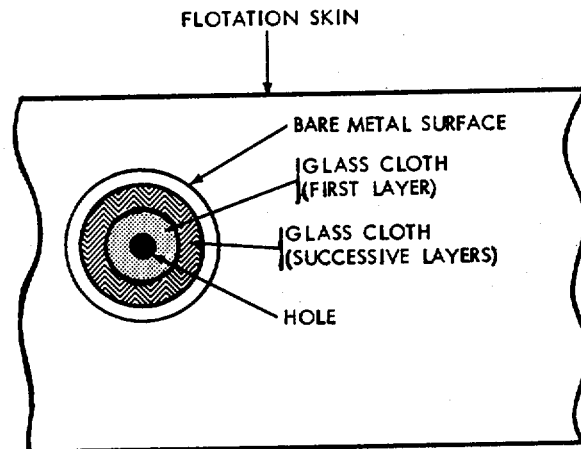

VIEW A

#### REPAIR OF HOLES OVER 2 INCHES IN DIAMETER

1. PREPARE SKIN SURFACE (ABOVE) AND CUT A PIECE OF ALUMINUM SCREEN SLIGHTLY LARGER THAN HOLE. SLIT SCREEN AROUND OUTER DIAMETER (VIEW B).
2. CUT SEVERAL PATCHES OF GLASS CLOTH IN SUCCESSIVELY LARGER DIAMETERS THAN WIRE SCREEN.
3. PREPARE RESIN AND HARDENER (IN REPAIR KIT).
4. WEAVE ALTERNATE SECTIONS OF SCREEN UNDER FLOTATION SKIN (VIEW C) AND THOROUGHLY SATURATE SCREEN WITH MIXTURE.
5. SATURATE CLOTH WITH MIXTURE AND FORM OVER SCREEN (VIEW D). REMOVE ALL AIR BUBBLES UNDER CLOTH.
6. SATURATE AND APPLY ONE OR MORE SUCCESSIVELY LARGER CLOTH PIECES OVER PATCH UNTIL PATCHED SURFACE IS SLIGHTLY ABOVE THAT OF FLOTATION SKIN.
7. PLACE A PIECE OF RELEASE FILM (FROM REPAIR KIT) OVER PATCH AND WITH HARDWOOD DEPRESSOR, WORK OUT ANY TRAPPED AIR BY WORKING FROM CENTER OF PATCH OUTWARD. REMOVE RELEASE FILM FROM PATCH.

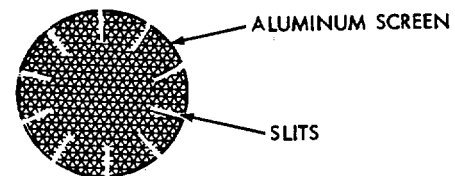

VIEW B

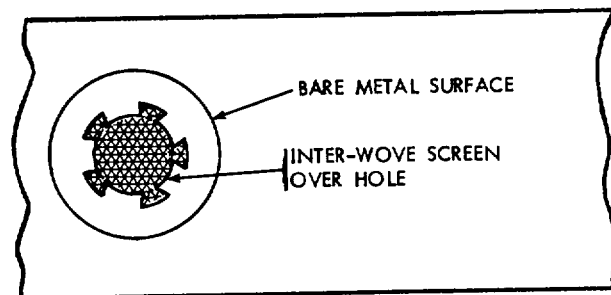

VIEW C

#### CURING, FINISHING, AND PAINTING PATCHED AREA

1. APPLY FINAL COAT OF EPOXY MIXTURE OVER PATCH AND ALLOW TO SET UNDISTURBED FOR 16 TO 24 HOURS.  
NOTE. CURE MAY BE EXPEDITED BY RAISING TEMPERATURE OF REPAIR AREA OR APPLYING HEAT TO PATCH.  
CAUTION: TEMPERATURE AT PATCH AREA MUST NOT EXCEED 100°F. FOR FIRST TWO HOURS OF CURE AND 250°F. THEREAFTER. CONTROL TEMPERATURE BY VARYING DISTANCE BETWEEN HEATING UNIT AND PATCH SURFACE.
2. ROUGH EDGES AND SURFACES OF CURED PATCHED AREA MAY BE SANDED LIGHTLY TO PROVIDE A SMOOTH FINISH. PAINT AS REQUIRED TO MINIMIZE DETECTION AND PROTECT ANY REMAINING BARE METAL SURFACES ( PAR. 8-5 ).

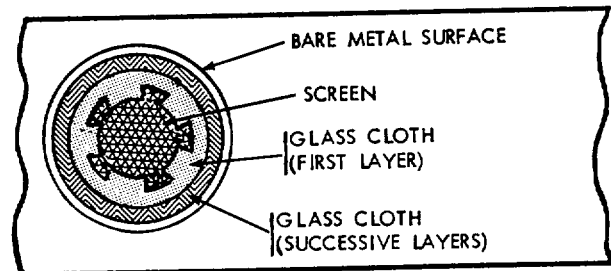

VIEW D

WE10950

Figure 9-148. Repair of flotation skin.

## 9.15. Barrier Repair

### a. General.

This procedure utilizes the cold patch technique (repair kit 5702943), and is intended for emergency field repairs at ambient temperatures above 250F. A vulcanizing fluid is used which achieves adhesion through chemical reaction with the red uncured rubber surface of the patch. The fluid is not a rubber cement, therefore, must be used in conjunction with the patches. Round patches are designed to accommodate holes up to 2" in diameter. Oblong patches are designed to accommodate tears less than 7" long. For tears longer than 7", oblong patches may be overlapped to achieve the necessary length of repair. Overlap should be at least 1-1/2" at the tear point.

### b. Repair Procedure.

- (1) Using a wire brush or other suitable roughener, buff an area around the tear or hole approximately 1" larger than the patch to be used.
- (2) Remove dust from buffed area. Make certain that the surface is perfectly dry. Failure to follow these instructions will result in an ineffective patch.

**CAUTION:** Do not use benzene or any other solvent.

- (3) Pour a sufficient amount of vulcanizing fluid from the can to form a thin layer, and spread over the

buffed area, using the top of the can, clean fingers, or a brush. Allow the spread fluid to dry from 3 to 5 minutes, depending on ambient temperatures. In extremely hot, dry X areas, the drying time may be reduced to as little as 1 minute. In cold areas, the drying time may exceed 5 minutes. The treated surface should be dry to touch before the patch is applied.

**NOTE.** If the fluid turns milky white after application, the surface is not perfectly dry or clean and Steps 1 and 2 above must be repeated.

- (4) Remove approximately 1/2 of the foil backing from the patch to be used, taking care not to touch the uncovered portion of the patch. Apply the uncovered (red uncured rubber) side of the patch to the prepared surface. Remove the remaining backing material and press patch into place. Roll out any bubbles or wrinkles from the patch by working from the center of the patch to the edges (edge of fluid can be used for this purpose). Make sure that the edge of the patch is adequately rolled.
- (5) Patch should be allowed to dry approximately 15 minutes to attain maximum adhesive strength, however, immediate use is permitted under emergency conditions.

**THIS PAGE LEFT BLANK INTENTIONALLY**

**9-154**

## CHAPTER 10 ORGANIZATIONAL MAINTENANCE-TURRET AND CUPOLA

---

**WARNING:** Before leaving vehicle, make certain that master switch and laser ON/OFF switch are in the OFF position. This is to prevent accidental automatic alignment of cupola to main weapon (M551A1 only).

### Section 10-1. TURRET ELECTRICAL SYSTEMS

#### 10-1. General

a. This section contains organizational maintenance instructions for the turret electrical systems which are classified into four categories according to their respective functions.

b. Figure 10-1 and table 10-1 identify and classify turret electrical components by primary systems. Maintenance instructions for each unit will be found in the section covering that specific system. Components housing multiple-system application are classified according to their primary function.

c. Refer to figure 10-2 for functional block diagram of turret electrical systems.

d. The missile subsystem checkout procedure is contained in table 2-12.

e. Vehicles serial numbers 140 through 223 are not equipped with the missile subsystem. Refer to figure 10-2. 1 for functional block diagram of electrical components on these vehicles.

**CAUTION:** Turn master switch off before disconnecting or connecting electrical connectors to avoid possible arcing.

### Section 10-2. ELECTRICAL DRIVE CONTROL SYSTEM

#### 10-2. General

a. This section contains organizational maintenance instructions for components of the electrical drive control system listed in table 10-2.

b. The elevation limit switch assembly is a component of the drive control system; however, it is serviced by support maintenance personnel.

c. Refer to figure 10-1 and table 10-1 for identification and locational reference of components of the system.

d. The electrical drive control system must be tested and balanced whenever a component of the system has been replaced. Perform complete system test procedures as outlined in figure 10-3 and table 10-3.

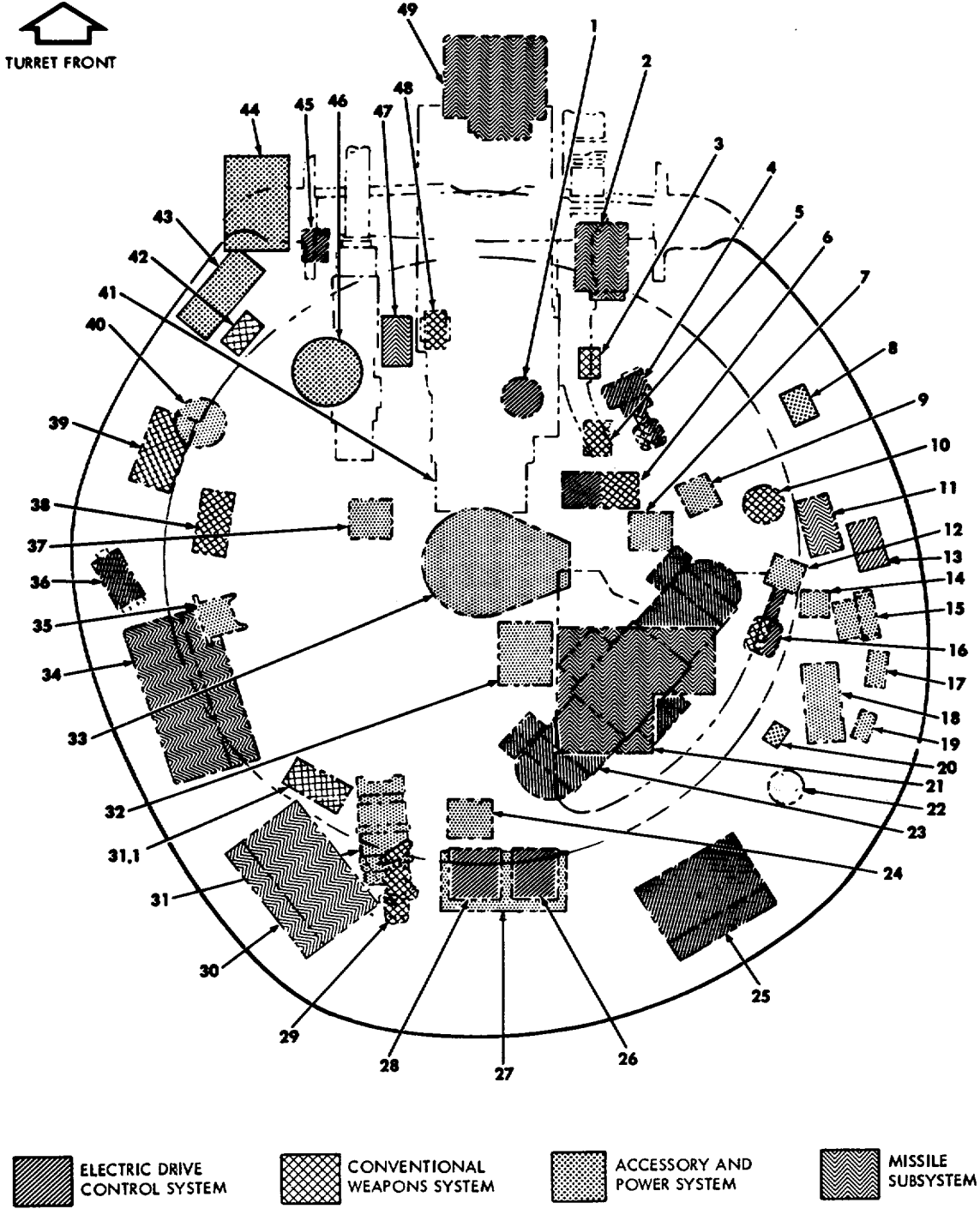

WE 11290A

Figure 10-1. Turret electrical systems - locational reference

TABLE 10-1. TURRET ELECTRICAL COMPONENTS - LOCATIONAL REFERENCE - (FIG. 10-1)

ITEM NO.	COMPONENT	ITEM NO.	COMPONENT
1	Elevating Mechanism Servo Motor	26	Amplifier Integrator Assembly
2	Missile Tracker Assembly	27	Receiver/Transmitter
3	Telescope Reticle Dimmer Box	28	Electric Drive Power Supply Assembly
4	Gunner's Control Handle Assembly	29	Blasting Machine Impulse Generator
5**	Telescope Emergency Power Supply	30	Modulator
6	Gun and Turret Control Selector	31	Antenna Matching Unit
7	Dome Light No. 1	31. 1	Breech Scavenge Compressor
8	Grenade Projector Power Supply	32	Air Filter Unit
9	Circuit Cutout Box	33	Electric Contact Ring
10	Azimuth Indicator B	34	Signal Data Converter
11	Checkout Panel	35	Loader's Intercom Control Box
		36	Gyro Selector Assembly
12	Grenade Projector Control Box	37	Dome Light No. 2
13	Traverse Mechanism Servo Motor	38	Loader's Control Box
14	Gunner's Intercom Control Box	39	Relay Box
15	Commander's Intercom Control Box	40	Forward Antenna
16	Commander's Control Handle Assembly	41	M81 Gun-Launcher
17	Cupola Control Box	42 #	120-Volt Power Supply
18	Radio Amplifier	43 *	Searchlight Main Control Box
19	Cupola Control Assembly	44 *	Searchlight
20*	Searchlight Remote Control Box	45	Elevation Limit Switches
21	Missile Subsystem Power Supply	46 #	Ventilating Blower (Fume Control)
22	Cupola Traversing Mechanism	47	Rate Sensor
23	Motor-Generator	48	Gun Safety Switch
24	Dome Light No. 3	49	Optical Transmitter
25	Accessory Box Assembly		

\*\* Effective On Vehicle No. 140.

# Effective On Vehicle No. 60 - Earlier Vehicles by Retrofit.

\* Special Purpose Kit (Refer to Chapter 12).

TABLE 10-2. Turret Electrical Drive Control System

ASSEMBLY OR COMPONENT	FIGURE REFERENCE		
	TEST	ADJUST	REMOVE/INSTALL
Accessory Box	10-3	10-4	10-4
Amplifier Integrator	10-3	10-5	10-5
Motor-Generator	10-3	10-6	
Gunner's and Commander's Control Handles	10-3	10-7	
Power Supply	10-3	10-8	
Gyro Selector	10-3	10-9	
Elevating and Traverse Mechanism Clutch Brushes			10-10
Elevating and Traverse Mechanism Servo Motors			10-11
Elevation and Depression Bump Stops		10-12	
Gun-Launcher Depression Control			10-13
Test Set, Electric Drive Control			10-3

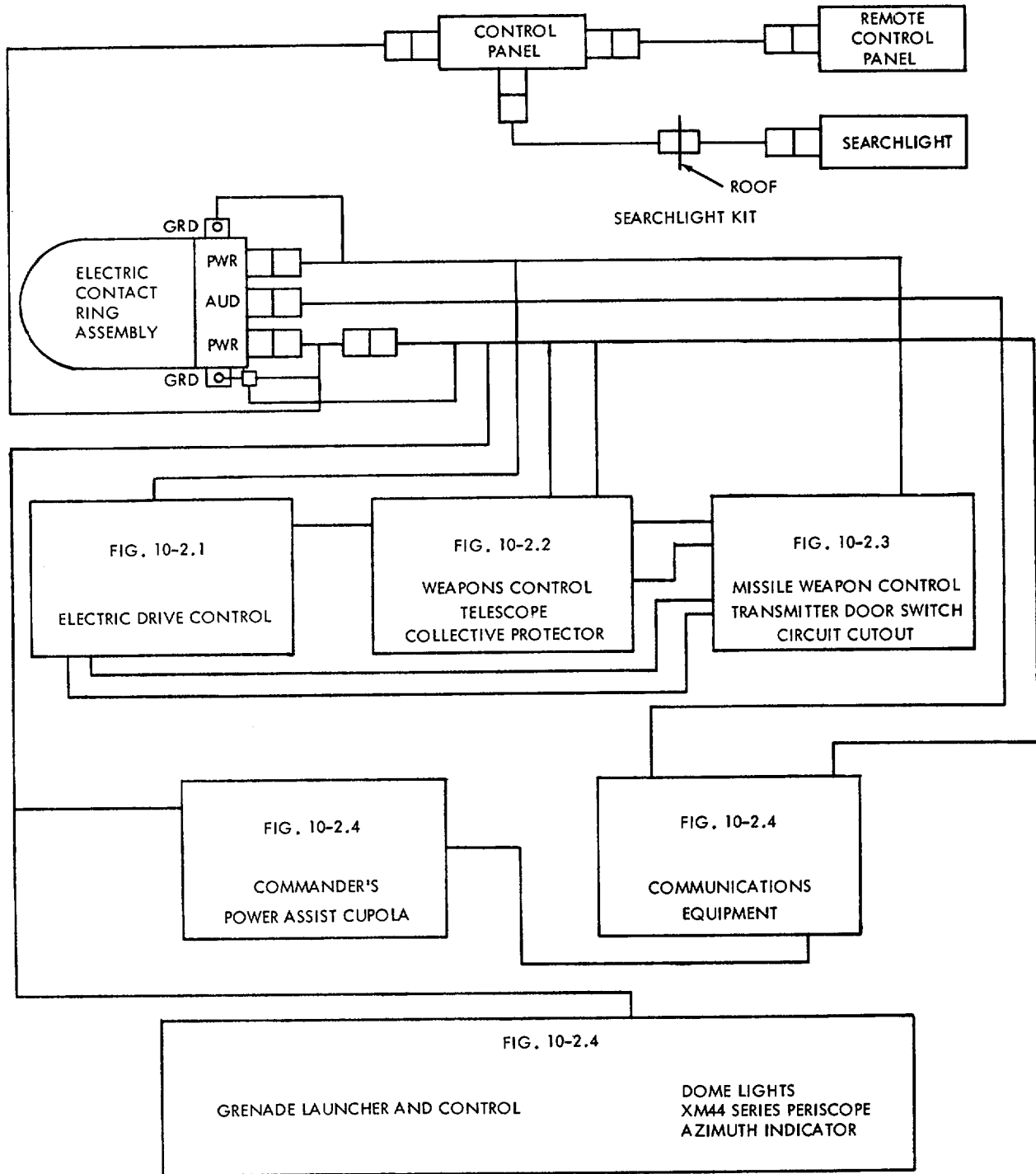

WE 66634

Figure 10-2. Turret electrical systems - functional block diagram (1 of 5)

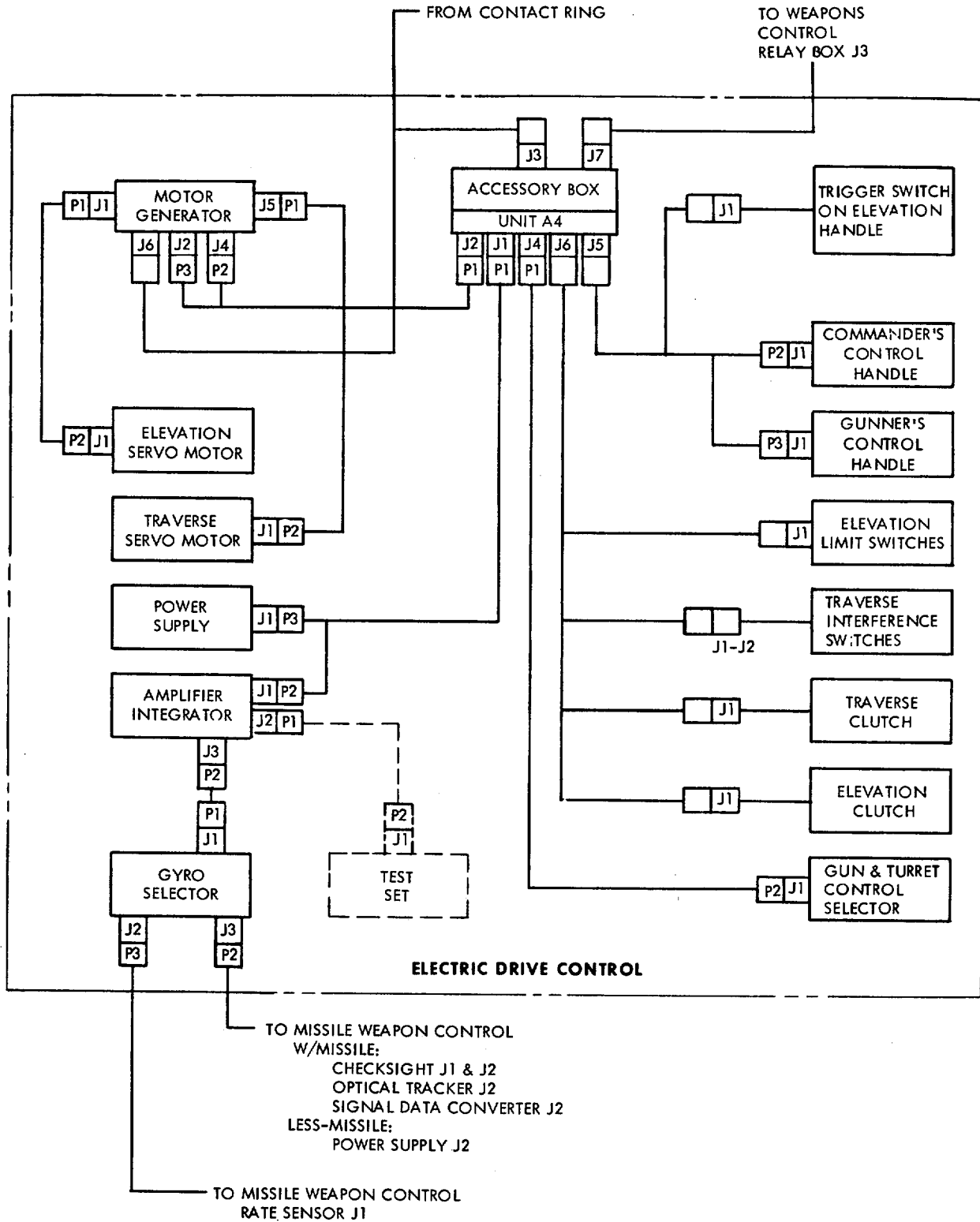

WE 66635

Figure 10-2.1. Turret electrical systems - functional block diagram (2 of 5)



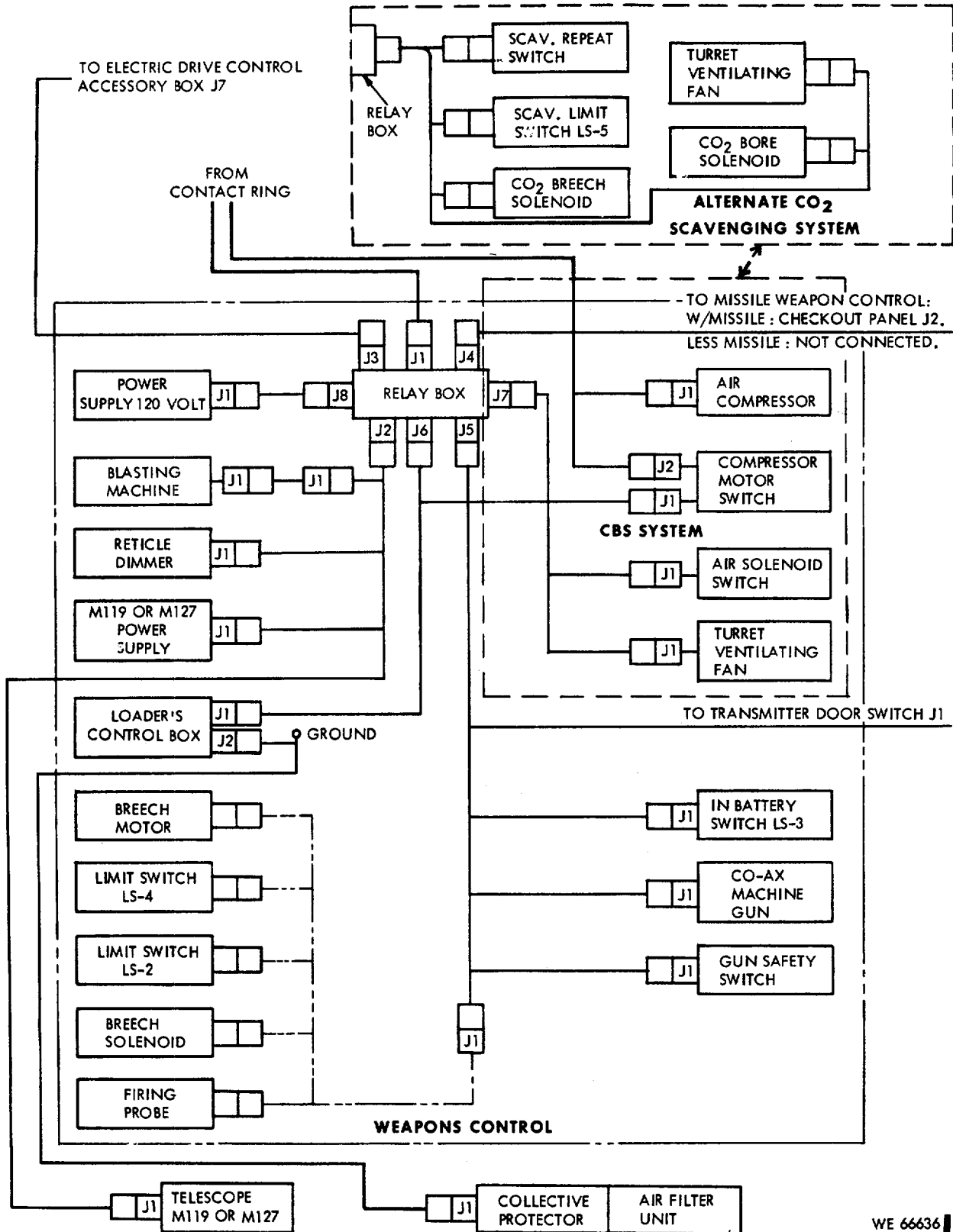

WE 66636

Figure 10-2.2. Turret electrical systems - functional block diagram (3 of 5)

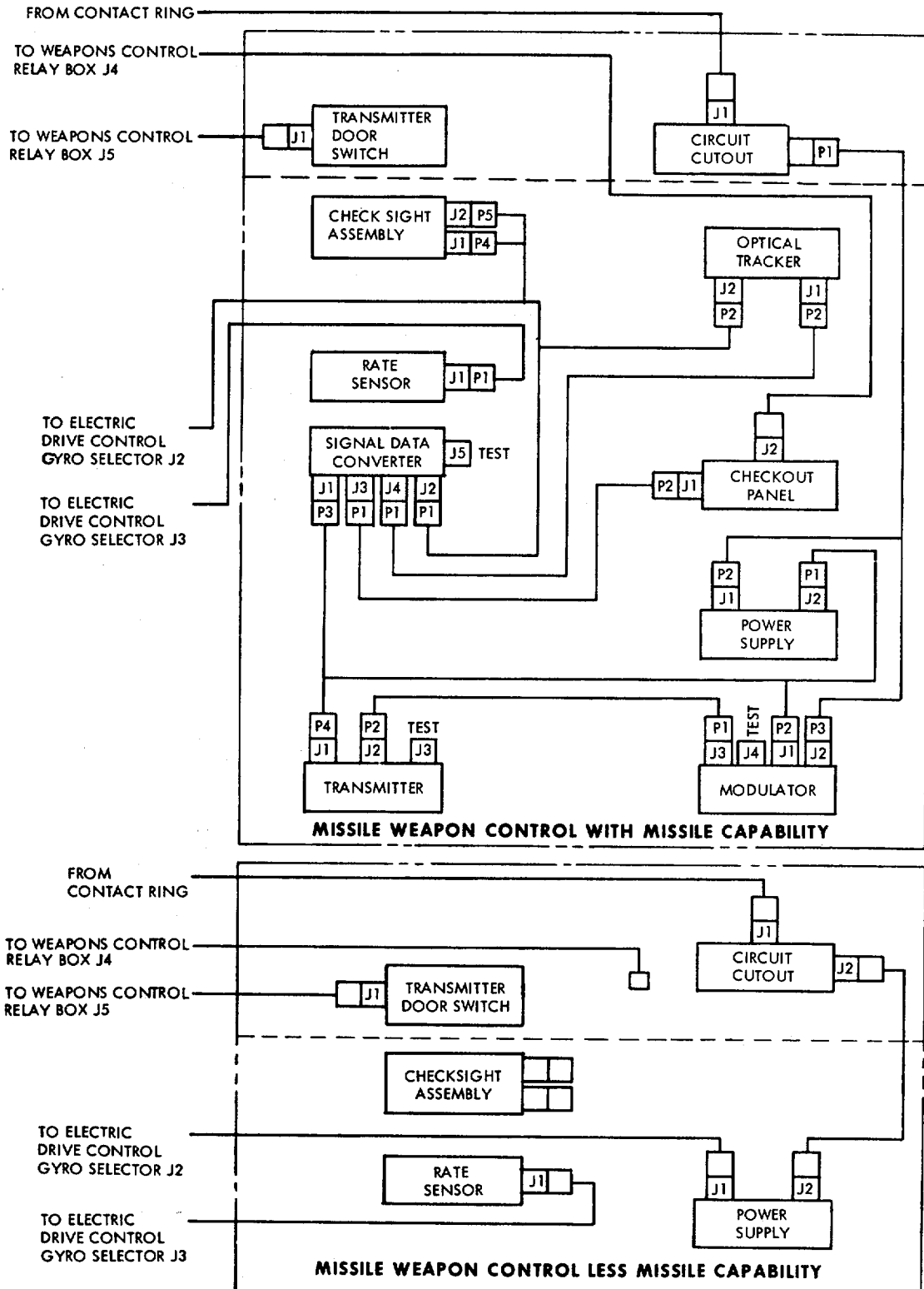

WE 66637

Figure 10-2.3. Turret electrical systems - functional block diagram (4 of 5)

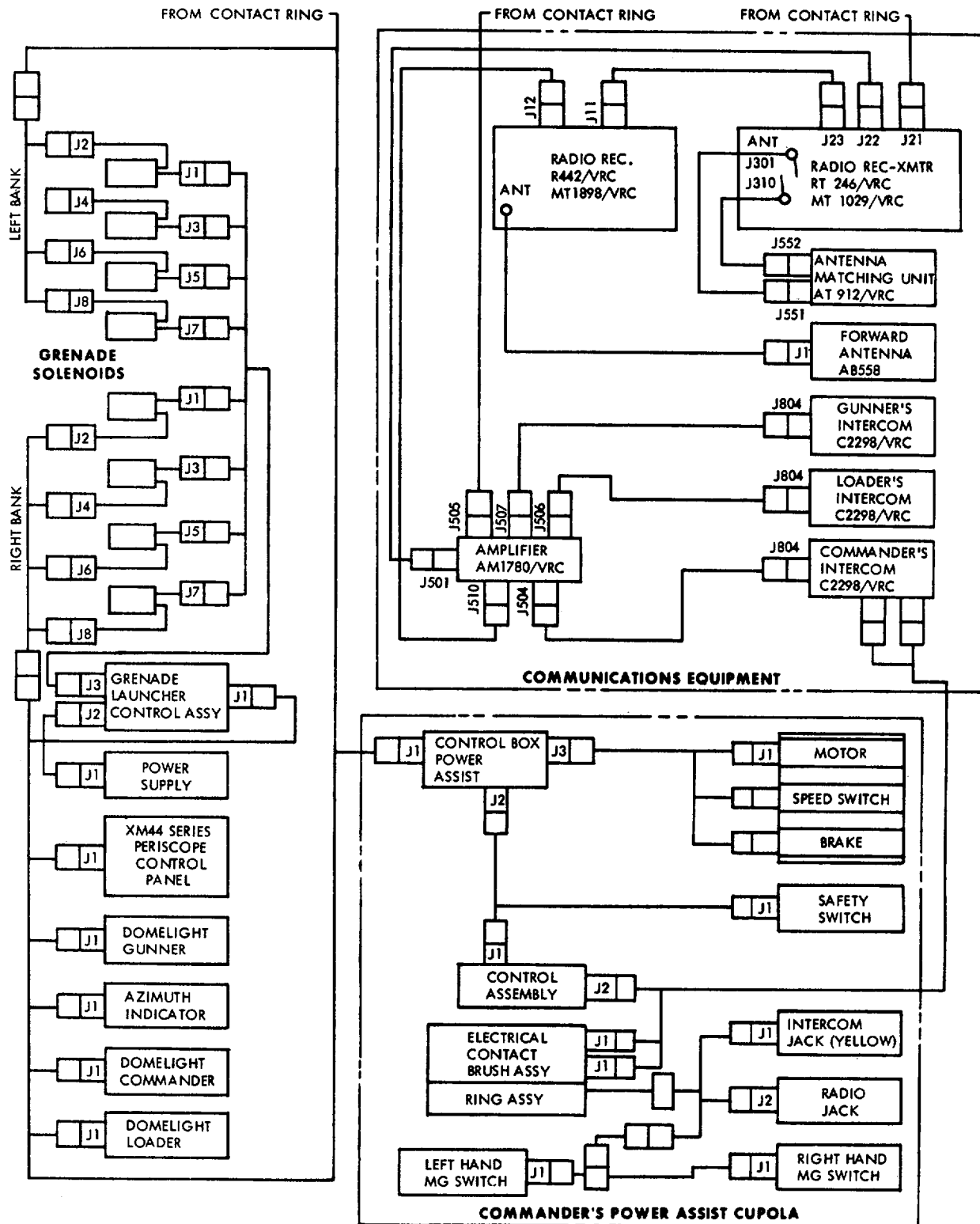

WE 66638

Figure 10-2.4. Turret electrical systems - functional block diagram (5 of 5)

Table 10-3. Electric Drive Control System Test Procedure

**GENERAL INSTRUCTIONS**

1. The electric drive control system test procedure provides isolation of trouble areas in the system. The test set, when connected to the system at the amplifier integrator and ON, will allow operation of the system with the traverse and elevation clutches and the motor-generator deenergized.
2. Perform test procedure in sequence for proper analysis. Observe indications at each test point and then proceed to NO-GO remedy, if required. If a malfunction is corrected by replacement, repeat test procedure. Attach tag with malfunction data (if known) to all components removed from turret.

**NOTE**

**Test set needle is self-locking. When either lamp is illuminated, the needle has pegged and locked. Needle may be released, providing current through meter is less than required to keep needle pegged, by pressing (press-to-test) illuminated lamp or rotating test set selector to the next position.**

3. Perform test procedure and balance electric drive control system whenever a control box or assembly is replaced in the system.
4. Notify support maintenance if any NO-GO condition cannot be corrected.
5. Refer to meter adjustment procedure for adjustment of locking arms
6. Check for proper voltage (27.5 to 29 volts) at dome light. Notify automotive mechanic if adjustment is required.

TEST PROCEDURE	REMEDY
----------------	--------

**TURN ON VEHICLE MASTER SWITCH  
AND TURRET DOME LIGHT**

Dome light illuminates



1. Check 28 volts at turret contact ring.
2. Check vehicle batteries.



Table 10-3. Electric Drive Control System Test Procedure  
--Continued



TEST PROCEDURE	REMEDY
<p>PLUG IN AND TURN ON TEST SET</p> <p style="text-align: center;"></p>	<p style="text-align: center;">NOTE</p> <p>When test set is connected and turned on, traverse and elevation mechanism magnetic clutches and motor-generator will not be energized when palm switches are depressed. This permits test to be accomplished without response of the turret or weapon from either control handle.</p>
<p>TP-1 POWER SUPPLY <math>\pm</math> 200 V</p>	
<p>TURN ON TURRET "POWER" SWITCH AT CONTROL SELECTOR</p>	
<p>Power light illuminates. If test needle deflects immediately, check/replace relay 4A2K1.</p> <p style="text-align: center;"></p>	<p style="text-align: center;"></p> <ol style="list-style-type: none"> <li>1. Check/replace bulb.</li> <li>2. Check/replace relay 4A8K1/board 4A1.</li> <li>3. Check 40 amp circuit breaker in accessory box.             <ol style="list-style-type: none"> <li>a. 28 volts at input side only, replace accessory box.</li> <li>b. 28 volts at both sides, notify support maintenance to check gun and turret control selector.</li> <li>c. No voltage at either side, notify support maintenance to check harness.</li> </ol> </li> </ol>

Table 10-3. Electric Drive Control System Test Procedure  
--Continued

TEST PROCEDURE	REMEDY
<p>TP-1 POWER SUPPLY ±200 V --Continued</p>	
<p>Ready light illuminates after 18-22 seconds time delay.</p>	<p><b>NO GO</b></p> <ol style="list-style-type: none"> <li>1. Check/replace bulb.</li> <li>2. If ready light does not illuminate within tolerance (18 to 22 seconds), adjust timer assembly in accessory box. Replace timer assembly if adjustment cannot be obtained.</li> <li>3. Press test set lights. <ol style="list-style-type: none"> <li>a. If test set lights fail to illuminate, check/replace: <ol style="list-style-type: none"> <li>(1) relay 4A5K1.</li> <li>(2) relay 4A1K2.</li> <li>(3) timer assembly 4A11.</li> <li>(4) if still NO-GO, replace accessory box.</li> </ol> </li> <li>b. If test set lights illuminate, notify support maintenance to check gun and turret control selector and harness.</li> </ol> </li> </ol>
<p>Meter deflects full right, Right/Up lamp illuminates. Servo motor fans off.</p>	<p><b>NO GO</b></p> <ol style="list-style-type: none"> <li>1. Check TP-2 -3, -6, -7 and -16. <ol style="list-style-type: none"> <li>a. If GO, check/replace relay 4A2K1.</li> <li>b. If NO-GO, check/replace power supply.</li> </ol> </li> <li>2. If servo motor fans start after time delay: <ol style="list-style-type: none"> <li>a. check/replace relay 4A1K1.</li> </ol> </li> </ol>

Table 10-3. Electric Drive Control System Test Procedure  
--Continued



TEST PROCEDURE	REMEDY
<p>TP-1 POWER SUPPLY <math>\pm 200</math> V --Continued</p>	
	<p>b. disconnect first gunner's then commander's control handle. If fans stop, replace disconnected handle. c. replace accessory box.</p>
<p>Partial Deflection of Meter</p>	<p>1. Refer to meter adjustment procedure for adjustment of locking arms.</p>
<p style="text-align: center;"></p>	<p>2. If still partial deflection at TP-1, -2, -3, -6, -7, and -16, IMMEDIATELY shut off system and check/replace: a. motor-generator. b. amplifier integrator. c. power supply.</p>
<p>TP-2 TRAVERSE HANDLE SUPPLY <math>\pm 14</math>V</p>	
<p>Meter deflects full right, Right/Up lamp illuminates.</p>	<p>Check/replace: 1. power supply. 2. amplifier integrator. 3. accessory box.</p>
<p style="text-align: center;"></p>	
<p>TP-3 ELEVATION HANDLE SUPPLY <math>\pm 14</math>V</p>	
<p>Meter deflects full right, Right/Up lamp illuminates.</p>	<p>See TP-2 NO-GO instructions.</p>
<p style="text-align: center;"></p>	

Table 10-3. Electric Drive Control System Test Procedure  
--Continued

TEST PROCEDURE	REMEDY
<p><b>TP-4 TRAVERSE CONTROL HANDLE OUTPUT (TEST BOTH HANDLES)</b></p>	
<p>Depress palm switch, ready light stays <u>ON</u> and motor-generator does <u>NOT</u> start. Center needle with TRAV button. Rotate handle right and left, needle deflects right and left.</p> <p style="text-align: center;">↓ <b>GO</b></p>	<p><b>NO GO</b></p> <ol style="list-style-type: none"> <li>1. If ready light goes out, check/replace relay 4A6K1.</li> <li>2. If motor-generator starts, check/replace relay 4A3K2.</li> <li>3. If either handle NO-GO, switch handles. If NO-GO changes to other handle, replace defective handle.</li> <li>4. If NO-GO on both handles or malfunction remains at commander's handle:             <ol style="list-style-type: none"> <li>a. check/replace relay 4A7K1.</li> <li>b. replace accessory box.</li> </ol> </li> </ol>
<p>Depress palm switch and observe (by feel) servo motor fan operation on both motors.</p> <p style="text-align: center;">↓ <b>GO</b></p>	<p><b>NO GO</b></p> <ol style="list-style-type: none"> <li>1. Check/replace relay 4A1K1, then 4A8K4.</li> <li>2. Replace defective servo motor.</li> <li>3. Replace accessory box.</li> </ol>
<p>Release palm switch, servo motor fans continue to operate for 2 to 3 seconds</p> <p style="text-align: center;">↓ <b>GO</b></p>	<p><b>NO GO</b></p> <ol style="list-style-type: none"> <li>1. If fans stop as soon as palm switch is released check/replace:             <ol style="list-style-type: none"> <li>a. relay 4A8K3.</li> <li>b. relay 4A2K2.</li> <li>c. timer assembly.</li> </ol> </li> <li>2. If fans operate longer than 3 seconds (approx 20 seconds) after releasing palm switch, check/replace:             <ol style="list-style-type: none"> <li>a. relay 4A6K1.</li> <li>b. timer assembly in accessory box.</li> </ol> </li> </ol>



Table 10-3. Electric Drive Control System Test Procedure  
--Continued







TEST PROCEDURE	REMEDY
<p>TP-5 ELEVATION CONTROL HANDLE OUTPUT (TEST BOTH HANDLES)</p>	
<p>Depress palm switch and center needle with ELEV trim button. Rotate handle backward and forward, needle deflects right and left respectively.</p> <p style="text-align: center;"></p>	<p> 1. See TP-4 NO-GO instructions 2. Check/replace board 4A10.</p>
<p>TP-6 POWER SUPPLY +15V</p> <p>Meter deflects full right, Right/Up lamp illuminates.</p> <p style="text-align: center;"></p>	<p> 1. Check/replace power supply. 2. Check/replace amplifier integrator.</p>
<p>TP-7 POWER SUPPLY -15V</p> <p>Meter deflects full left, Left/Down lamp illuminates.</p> <p style="text-align: center;"></p>	<p> 1. See TP-6 NO-GO instructions. 2. If only partial deflection of test meter, refer to meter adjustment procedure for adjustment of locking arms.</p>

Table 10-3. Electric Drive Control System Test Procedure  
--Continued





TEST PROCEDURE	REMEDY
<p>TP-10 TRAVERSE INTEGRATOR INPUT (TEST BOTH HANDLES)</p> <hr/> <p>Depress palm switch and rotate handle right and left, needle deflects right and left.</p> <p style="text-align: center;"></p>	<p style="text-align: center;"></p> <ol style="list-style-type: none"> <li>1. If deflections were obtained at TP-4, turn TRAV gain pot 2R1 fully ccw, then one-fourth turn cw.</li> <li>2. Check/replace:               <ol style="list-style-type: none"> <li>a. relay 4A6K4.</li> <li>b. relay 4A7K3.</li> <li>c. circuit board 4A16.</li> </ol> </li> <li>3. Replace:               <ol style="list-style-type: none"> <li>a. accessory box.</li> <li>b. amplifier integrator.</li> </ol> </li> </ol>
<p>TP-11 ELEVATION INTEGRATOR INPUT (TEST BOTH HANDLES)</p> <hr/> <p>Depress palm switch and rotate handle backward and forward, needle deflects right and left respectively.</p> <p style="text-align: center;"></p>	<p style="text-align: center;"></p> <ol style="list-style-type: none"> <li>1. Insure weapon is out of elevation and depression limit switch control zone.</li> <li>2. If deflections were obtained at TP-5, turn ELEV gain pot 2R2 fully ccw, then one-fourth turn cw.</li> <li>3. Check/replace:               <ol style="list-style-type: none"> <li>a. relay 4A6K4.</li> <li>b. relay 4A7K3.</li> <li>c. relay 4A9K1.</li> <li>d. relay 4A9K2.</li> <li>e. circuit board 4A15.</li> <li>f. circuit board 4A10.</li> </ol> </li> </ol>

Table 10-3. Electric Drive Control System Test Procedure  
--Continued



TEST PROCEDURE	REMEDY
<p><b>TP-11 ELEVATION INTEGRATOR INPUT (TEST BOTH HANDLES)</b> --Continued</p>	<p>4. Disconnect cable at 4J6; if GO, notify support maintenance to check/replace:</p> <ol style="list-style-type: none"> <li>a. cable.</li> <li>b. limit switches.</li> </ol> <p>5. Replace:</p> <ol style="list-style-type: none"> <li>a. accessory box.</li> <li>b. amplifier integrator.</li> </ol>
<p><b>TP-14 TRAVERSE INTEGRATOR OUTPUT</b></p> <p>Meter at null position with palm switch released.</p> <div style="text-align: center;">  </div>	<div style="text-align: center;">  </div> <p>1. Adjust traverse integrator balance pot (2A2 circuit board) for null on meter. Rotate pot in direction of desired needle movement.</p> <p>2. Check TP-15.</p> <ol style="list-style-type: none"> <li>a. If TP-15 is GO, switch elevation and traverse integrators. If TP-14 is now GO, replace defective integrator.</li> <li>b. If TP-15 is NO-GO, or TP-14 is still NO-GO, replace amplifier integrator.</li> </ol>

Table 10-3. Electric Drive Control System Test Procedure  
--Continued





TEST PROCEDURE	REMEDY
<p>TP-15 ELEVATION INTEGRATOR OUTPUT</p>	
<p>Meter at null position with palm switch released.</p> <p style="text-align: center;"></p>	<p style="text-align: center;"></p> <ol style="list-style-type: none"> <li>1. Adjust elevation integrator balance pot (2A4 circuit board) for null on meter. Rotate pot in direction of desired needle movement.</li> <li>2. Check TP-14.               <ol style="list-style-type: none"> <li>a. If TP-14 is GO, switch traverse and elevation integrators. If TP-15 is now GO, replace defective integrator.</li> <li>b. If TP-14 is NO-GO, or TP-15 is still NO-GO, replace amplifier integrator.</li> </ol> </li> </ol>
<p>TP-12 TRAVERSE AMPLIFIER OUTPUT (TEST BOTH HANDLES)</p>	
<p>Meter at null position with palm switch released. Depress palm switch and center needle with TRAV trim button; rotate handle right and left, needle deflects right and left.</p> <p style="text-align: center;"></p>	<p style="text-align: center;"></p> <ol style="list-style-type: none"> <li>1. Adjust traverse amplifier balance pot (2A1 circuit board) for null on meter. Rotate pot in direction of desired needle movement.</li> </ol>

Table 10-3. Electric Drive Control System Test Procedure  
--Continued



TEST PROCEDURE	REMEDY
<p>TP-12 TRAVERSE AMPLIFIER OUTPUT (TEST BOTH HANDLES)--Continued</p>	<ol style="list-style-type: none"> <li>2. Check TP-13.               <ol style="list-style-type: none"> <li>a. If TP-13 is GO, switch elevation and traverse amplifiers. If TP-12 is now GO, replace defective amplifier.</li> <li>b. If TP-13 is NO-GO, or TP-12 is still NO-GO, replace:                   <ol style="list-style-type: none"> <li>(1) amplifier integrator.</li> <li>(2) motor-generator.</li> </ol> </li> </ol> </li> </ol>
<p>TP-12 TACH GENERATOR FEEDBACK (TRAVERSE)</p> <p>With palm switch released, manually traverse turret to right and left. Needle should deflect in opposite direction of turret movement.</p> <p style="text-align: center;"></p>	<ol style="list-style-type: none"> <li>1. Switch elevation and traverse servo motors. If TP-12 is now GO, replace defective motor.</li> <li>2. Check/replace circuit board 4A16.</li> </ol>
<p>TP-13 ELEVATION AMPLIFIER OUTPUT (TEST BOTH HANDLES)</p> <p>Meter at null position with palm switch released. Depress palm switch and center needle with ELEV trim button. Rotate handle backward and forward, needle deflects right and left respectively.</p> <p style="text-align: center;"></p>	<ol style="list-style-type: none"> <li>1. Adjust elevation amplifier balance pot (2A3 circuit board) for null on meter. Rotate pot in direction of desired needle movement.</li> </ol>

Table 10-3. Electric Drive Control System Test Procedure  
--Continued





TEST PROCEDURE	REMEDY
<p>TP-13 ELEVATION AMPLIFIER OUTPUT (TEST BOTH HANDLES)--Continued</p>	<ol style="list-style-type: none"> <li>2. Check TP-12.               <ol style="list-style-type: none"> <li>a. If TP-12 is GO, switch traverse and elevation amplifiers. If TP-13 is now GO, replace defective amplifier.</li> <li>b. If TP-12 is NO-GO, or TP-13 is still NO-GO, replace:                   <ol style="list-style-type: none"> <li>(1) amplifier integrator</li> <li>(2) motor-generator.</li> </ol> </li> </ol> </li> </ol>
<p>TP-13 TACH GENERATOR FEEDBACK (ELEVATION)</p> <p>With palm switch released, <u>manually</u> elevate and depress weapon. Needle should deflect left for elevation and right for depression.</p> <p style="text-align: center;"></p>	<p style="text-align: center;"></p> <ol style="list-style-type: none"> <li>1. Switch traverse and elevation servo motors. If TP-13 now GO, replace defective servo motor.</li> <li>2. Check/replace circuit board 4A15.</li> </ol>
<p>TP-16 POWER SUPPLY -60V</p> <p>Needle deflects full left, Left/Down lamp illuminates.</p> <p style="text-align: center;"></p>	<p style="text-align: center;"></p> <p>Check/replace power supply.</p>

Table 10-3. Electric Drive Control System Test Procedure  
--Continued

TEST PROCEDURE	REMEDY
<p>TP-16 POWER SUPPLY -60V --Continued</p>	
<p>TURN ON "STAB" SWITCH ON CONTROL SELECTOR</p>	
<p>STAB light illuminates</p> <p style="text-align: center;">↓</p> <p style="text-align: center;">GO</p>	<p style="text-align: center;">NO GO</p> <ol style="list-style-type: none"> <li>1. Check bulb, replace if defective.</li> <li>2. Insure fire control selector is NOT on MISSILE.</li> <li>3. Check harness between rate sensor and gyro selector for loose connections.</li> <li>4. Check/replace relay 4A6K2.</li> <li>5. Perform missile guidance and control system checkout procedures. If GO, replace:             <ol style="list-style-type: none"> <li>a. gyro selector.</li> <li>b. accessory box.</li> <li>c. Notify support maintenance to check gun and turret control selector and harness.</li> </ol> </li> </ol>
<p>TURN FIRE CONTROL SELECTOR TO "MISSILE"</p>	
<p>STAB light goes out</p> <p style="text-align: center;">↓</p> <p style="text-align: center;">GO</p>	<p style="text-align: center;">NO GO</p> <p>Check/replace relay 4A6K2.</p>
<p>TURN FIRE CONTROL SELECTOR TO "OFF"</p>	
<p>STAB light illuminates.</p> <p style="text-align: center;">↓</p> <p style="text-align: center;">GO</p>	

Table 10-3. Electric Drive Control System Test Procedure  
--Continued



TEST PROCEDURE	REMEDY
<p>TP-8 TRAVERSE GYRO OUTPUT (RATE SENSOR)</p>	
<p>Needle should be near center.</p>	<p>If fully deflected, perform missile guidance and control system checkout procedures.</p>
<p>Manually traverse right, Left/Down lamp illuminates. Traverse left, Right/Up lamp illuminates.</p>	<p>Perform missile guidance and control system checkout procedures. If GO, replace gyro select</p>
	
<p>TP-9 ELEVATION GYRO OUTPUT (RATE SENSOR)</p>	
<p>Needle should be near center.</p>	<p>If fully deflected, perform missile guidance and control system checkout procedures.</p>
<p>Manually elevate weapon, Left/Down lamp illuminates. Depress weapon, Right/Up lamp illuminates.</p>	<p>Perform missile guidance and control system checkout procedures. If GO, replace gyro selector.</p>
	
<p>TP-12 TRAVERSE AMPLIFIER OUTPUT</p>	
<p>Depress palm switch, meter at null position. Rotate handle right and left, needle deflects right and left.</p>	<p>1. Adjust traverse gyro balance pot (circuit board 4A12) in same direction as needle is deflected.</p>
	



Table 10-3. Electric Drive Control System Test Procedure  
--Continued

TEST PROCEDURE	REMEDY
<p><b>TP-12 TRAVERSE AMPLIFIER OUTPUT--Continued</b></p> <hr/> <p style="text-align: center;"><i>NOTE</i></p> <p><i>With palm switch depressed and handle centered, no movement of needle should occur when switching from stab to nonstab modes.</i></p>	<ol style="list-style-type: none"> <li>2. Check TP-13 (STAB mode). If TP-13 is GO, switch elevation and traverse amplifier assemblies (4A13 and 4A12). If TP-12 is now GO replace defective amplifier assembly.</li> <li>3. Check replace relay 4A7K3.</li> <li>4. Turn traverse summing gain pot (circuit board 4A16) 15 full turns ccw.</li> <li>5. Replace circuit board 4A14.</li> </ol>
<p><b>TP-13 ELEVATION AMPLIFIER OUTPUT</b></p> <hr/> <p>Depress palm switch, meter at null position. Rotate handle backward and forward, needle deflects right and left respectively.</p> <p style="text-align: center;"><i>NOTE</i></p> <p><i>With palm switch depressed and handle centered, no movement of needle should occur when switching from stab to nonstab modes.</i></p> <div style="text-align: center;">  </div>	<ol style="list-style-type: none"> <li>1. Adjust elevation gyro balance pot (circuit board 4A13) in same direction as needle is deflected.</li> <li>2. Check TP-12 (STAB mode). If TP-12 is GO, switch traverse and elevation amplifier assemblies (4A12 and 4A13). If TP-13 is now GO, replace defective amplifier assembly.</li> <li>3. Check/replace relay 4A7K3.</li> <li>4. Turn elevation summing gain pot (circuit board 4A15) 15 full turns ccw.</li> <li>5. Replace circuit board 4A14.</li> </ol>

Table 10-3. Electric Drive Control System Test Procedure  
--Continued

TEST PROCEDURE	REMEDY
<p>RETURN TEST SET SELECTOR TO ZERO "0" POSITION AND TURN OFF TEST SET</p>	

**CAUTION**

Make sure test set SELECTOR is on "0" when test set is turned off.

**FINAL GAIN AND BALANCING PROCEDURES**

*NOTE*

*Final balancing of the system for both stabilized and nonstabilized modes should be performed with engine running. Vibration caused by engine or voltage ripple caused by the generating system will in no way affect turret test set. However, following use of test set and/or when general troubleshooting an electrical circuit, running of the engine is not recommended.*

1. Operate the electric drive control system.

*NOTE*

*The electric drive system may be operated with the test set connected providing:*

- a. *Test set selector is on "0".*
- b. *Test set switch is in "OFF" position.*

2. The system gain is properly adjusted when weapon or turret does not oscillate when palm switch is depressed.

- a. If oscillation occurs in non-stabilized mode, Turn ELEV and TRAV gain pots in amplifier integrator clockwise until oscillation stops.

Table 10-3. Electric Drive Control System Test Procedure  
--Continued

---

**FINAL GAIN AND BALANCING PROCEDURES**

---

**NOTE**

*Do not turn gain pots to within 60' or less of the clockwise stop.*

b. If oscillation occurs in stabilized mode, adjust summing gain pots (4A15 circuit board) (ELEV) and 4A16 circuit board (TRAV) clockwise until oscillation stops.

3. The system balance is properly adjusted when weapon or turret does not drift with palm switch depressed, or during the 2 or 3 seconds drop-out delay after palm switch is released.

a. Drift with palm switch depressed (Non-stabilized Mode). With palm switch depressed eliminate drift with control handle trim buttons. Check both control handles.

b. Drift During 2 to 3 Seconds Drop-Out Delay. With palm switch released, eliminate drift on circuit boards 2A1 traverse and 2A3 elevation (amplifier balance pots); then again check for drift during drop-out delay. Repeat till drift is eliminated. If drift is too severe, it may be necessary to adjust the motor-generator balance pots R-10 (TRAV or ELEV) to eliminate drift. If an adjustment is made to eliminate drift during the drop-out delay, repeat check for drift in nonstabilized mode.

**NOTE**

*Do not readjust trim buttons to eliminate drift in stabilized mode.*

c. Drift with Palm Switch Depressed (Stabilized Mode). With palm switch depressed eliminate drift with gyro balance pots 4A12 (TRAV) and 4A13 (ELEV) circuit boards.

**10-8.12**

Table 10-3. *Electric Drive Control System Test Procedure*  
--Continued

---

**METER ADJUSTMENT PROCEDURE**

---

**Electronic Test Set (4933-00-909-9356)**

Turn on turret power switch; ready light illuminates after 18 to 22 seconds. With multimeter, check +15 volts at pin "D" and -15 volts at pin WE" of amplifier integrator test set receptacle (J2).

1. If voltage at pin "D" is from +14 to +16 volts and voltage at pin "E" is from -14 to -16 volts, turn off turret power, reconnect test set harness to receptacle and turn on turret power. Wait until ready light illuminates.
  2. Place test set selector to TP-6 and move red arm on right of test set meter to the left until Right/Up lamp illuminates.
  3. Place test set selector to TP-7 and move red arm on left of test set meter to the right until Left/Down lamp illuminates.
-

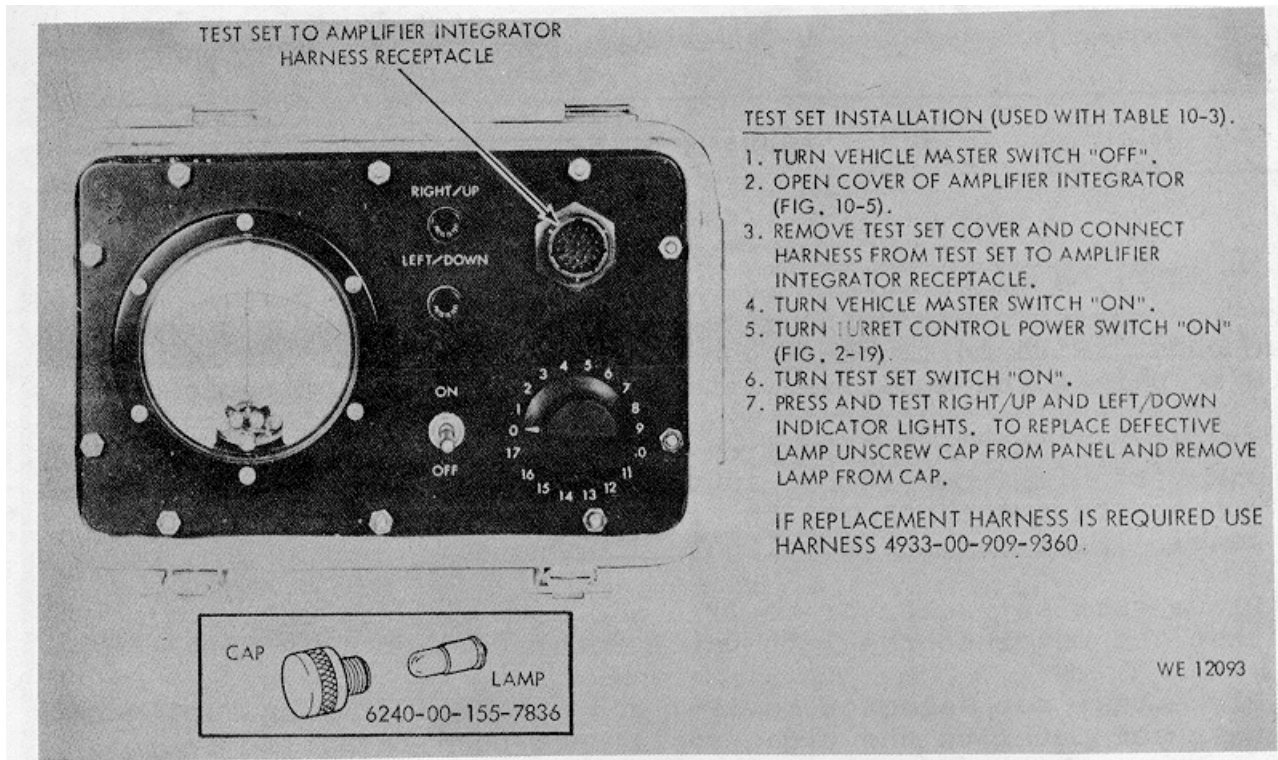

Figure 10-3. Electric drive control test set.

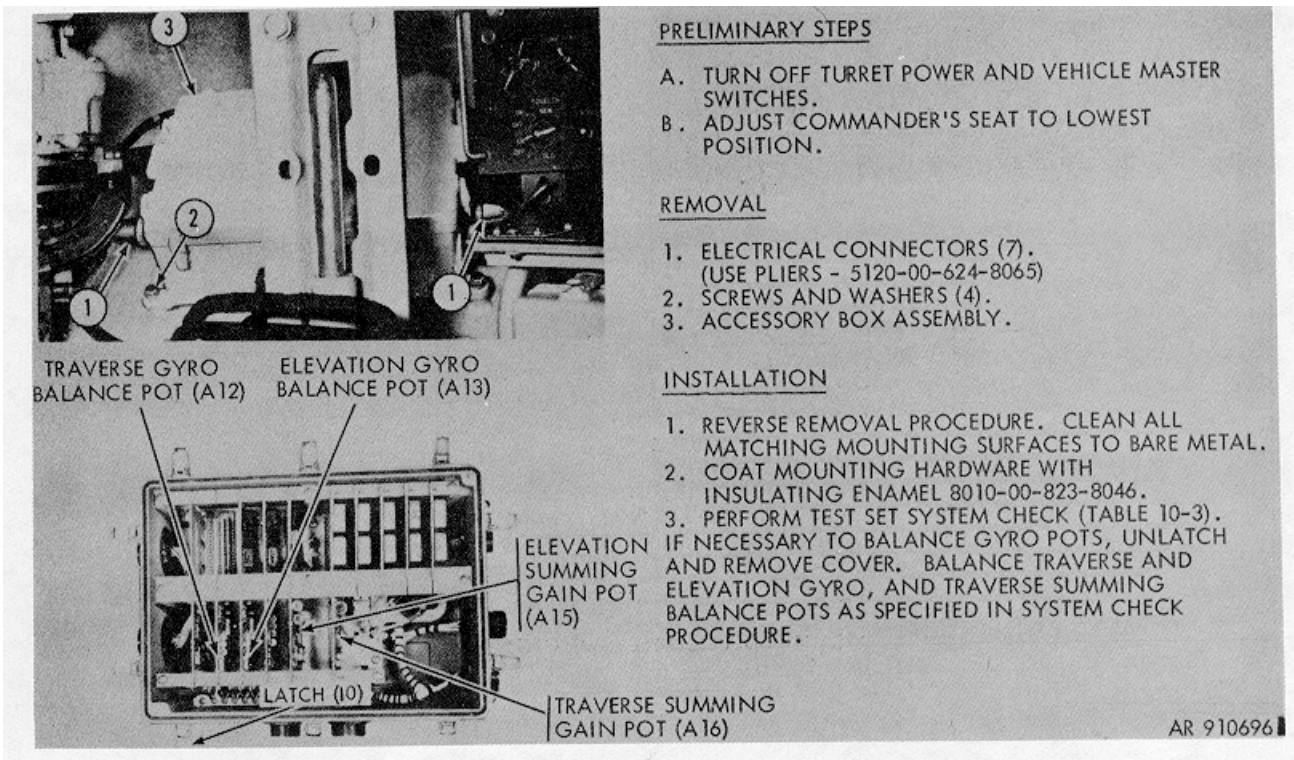
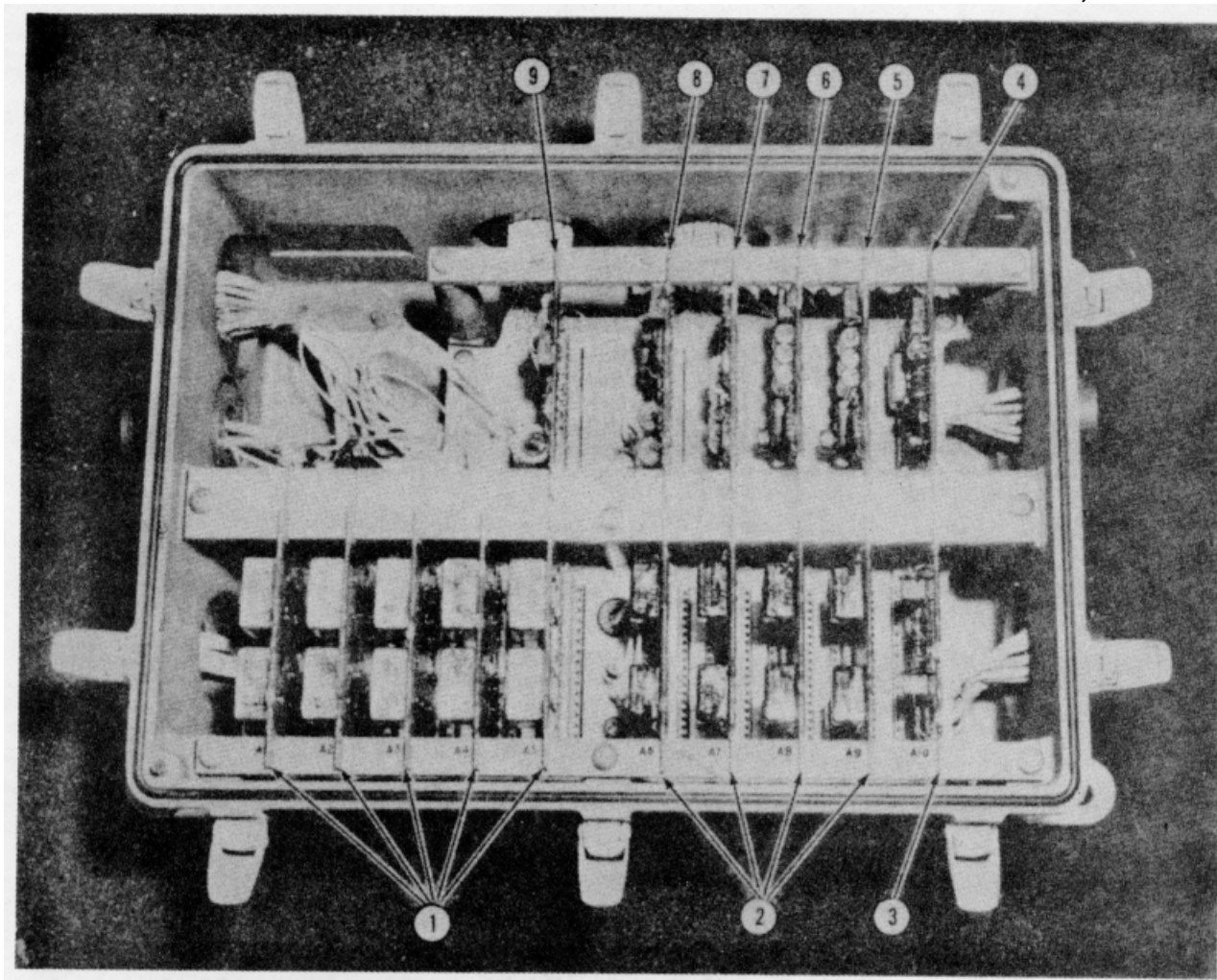

Figure 10-4. Removal/installation/adjust - accessory box.



### LEGEND

1. RELAY ASSY (A-1, A-2, A-3, A-4, A-5)
2. RELAY ASSY (A-6, A-7, A-8, A-9)
3. PRINTED CIRCUIT CONTROL BOARD (A-10)
4. TIMER ASSY (A-11)
5. TRAVERSE AMPLIFIER ASSY (A-12)
6. ELEVATION AMPLIFIER ASSY (A-13)
7. SHAPING AND FILTER ASSY (A-14)
8. ELEVATION SUMMING ASSY (A-15)
9. TRAVERSE SUMMING ASSY (A-16)

### REPAIR

REPLACE UNSERVICEABLE COMPONENTS  
AS REQUIRED.

*Figure 10-4.1. Repair of accessory box assembly*

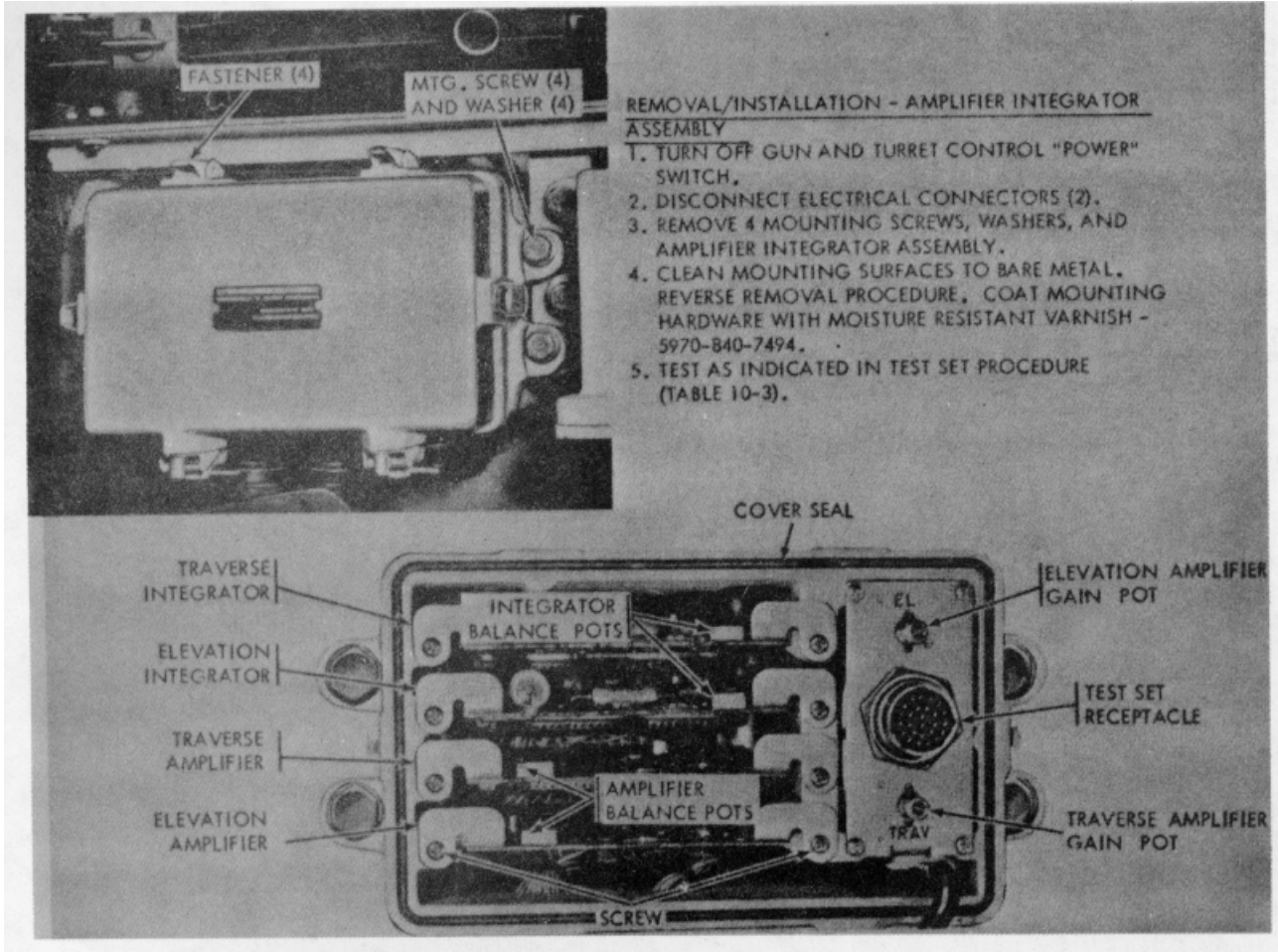

WE 11265A

Figure 10-5. Removal/installation - amplifier integrator assembly

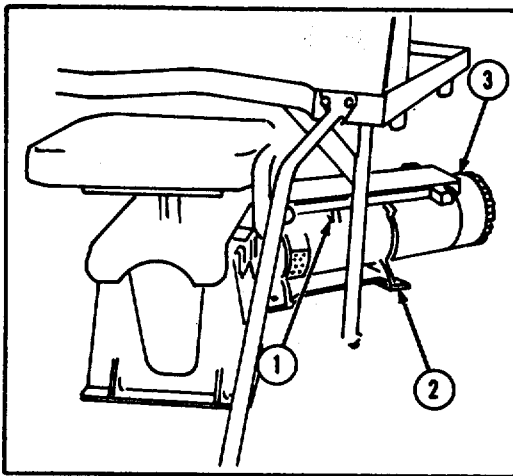

VIEW - A

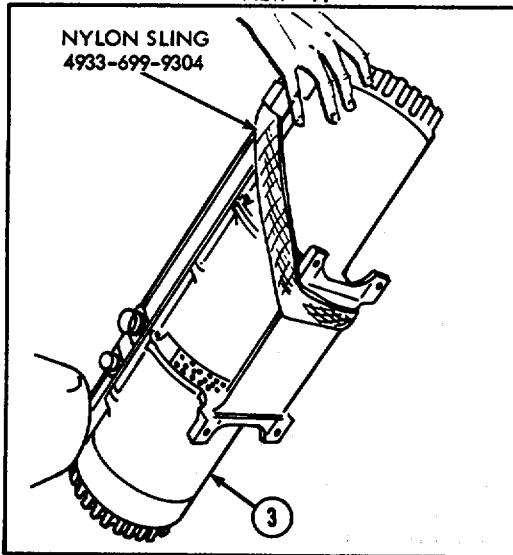

VIEW - B

**PRELIMINARY STEPS**

- A. REMOVE GUNNER'S SCREENS.
- B. DISCONNECT ELECTRICAL LEADS FROM CIRCUIT CUTOUT BOX (FIG. 10-27).
- C. REMOVE 4 SCREWS AND WASHERS TO PERMIT GUNNER'S SEAT ASSEMBLY TO BE MOVED FOR CLEARANCE (ITEMS 2 AND 3, FIGURE 10-40).
- D. TRAVERSE TURRET UNTIL MOTOR-GENERATOR IS ACCESSIBLE FROM DRIVER'S COMPARTMENT.

**REMOVAL**

1. ELECTRICAL CONNECTORS (5) (USE PLIERS 5120-624-8065)
2. SCREW (4) AND LOCK WASHER (4)
3. MOTOR-GENERATOR
4. DROP NYLON SLING THROUGH DRIVER'S HATCH AND SECURE MOTOR-GENERATOR AS SHOWN IN VIEW B. REMOVE MOTOR-GENERATOR THROUGH DRIVER'S HATCH WITH SUITABLE LIFTING DEVICE.

**INSTALLATION**

REVERSE REMOVAL PROCEDURE.

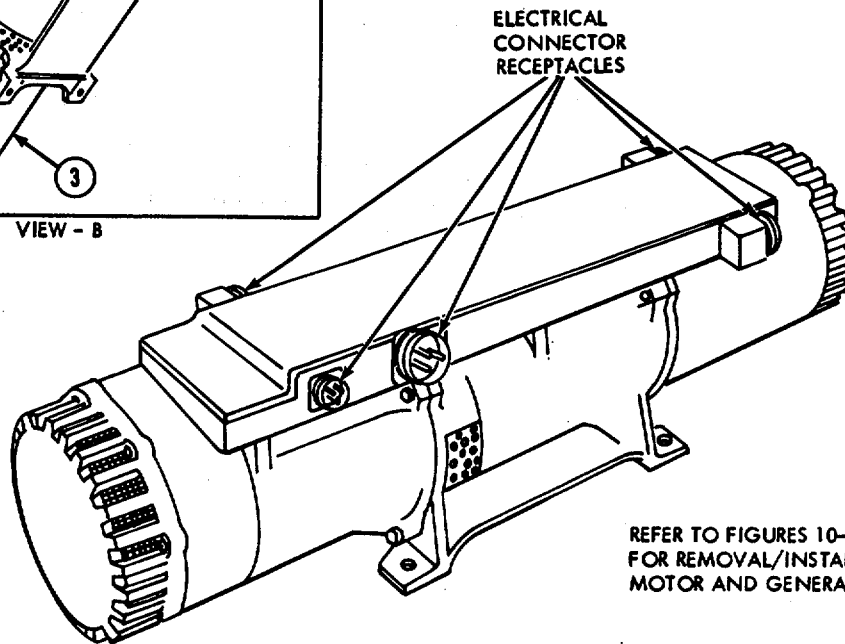

REFER TO FIGURES 10-6.1 AND 10-6.2 FOR REMOVAL/INSTALLATION OF MOTOR AND GENERATOR BRUSHES.

MOTOR GENERATOR (CURRENT DESIGN)

WE 66576

Figure 10-6. Removal/installation - motor-generator assembly



REMOVAL - MOTOR BRUSHES

1. REMOVE MOTOR GENERATOR FROM VEHICLE (FIG. 10-6).
2. REMOVE 8 SCREWS, FLAT WASHERS, LOCK WASHERS, AND UPPER AND LOWER BRUSH ACCESS COVERS (VIEW A).

**NOTE.** IF UPPER COVER IS DIFFICULT TO REMOVE REMOVE NUT AND WASHER (A, VIEW A) AND RETRACT SCREW SO THAT COVER CAN BE BENT FLAT AGAINST CONTROL BOX TO PROVIDE ACCESS TO BRUSHES.

3. USE OFFSET PHILLIPS SCREWDRIVER 5120-256-9014 TO REMOVE SCREW (4), WASHER (4) AND BRUSH LEADS (4) (VIEW B).
4. USE SMALL PIECE OF WIRE BENT TO J-HOOK TO RETRACT BRUSH HOLD-DOWN SPRING WHILE REMOVING BRUSH. REMOVE 4 BRUSH ASSEMBLIES (8 SECTIONS).

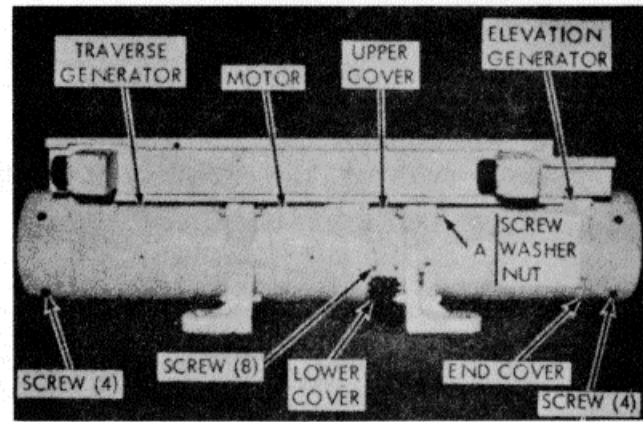

VIEW A

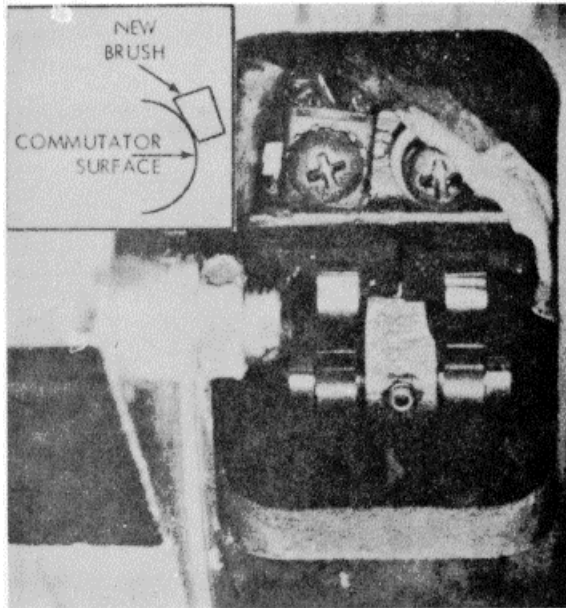

VIEW B

OTHER MAINTENANCE

ALL OTHER MAINTENANCE ON MOTOR GENERATOR IS PERFORMED BY SUPPORT MAINTENANCE. END BELL (VIEW C) IS FACTORY ADJUSTED FOR POLARITY BALANCE AND SHOULD NEVER REQUIRE READJUSTMENT.

INSTALLATION

1. REVERSE REMOVAL PROCEDURE

**CAUTION:** BRUSHES MUST BE INSTALLED SO CHAMFER IS TANGENT TO COMMUTATOR SURFACE (INSET, VIEW B).

2. NEW BRUSHES MUST BE RUN IN BY OPERATING MOTOR UNTIL 75% OF BRUSH SURFACE IS IN CONTACT WITH COMMUTATOR SURFACE. (INSET, VIEW C). RUN-IN TIME IS APPROXIMATELY 8 HOURS.

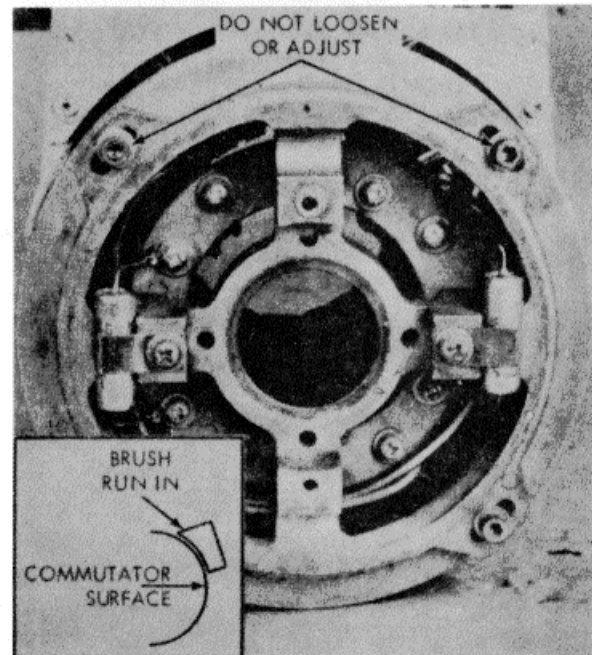

VIEW C

WE 12198

Figure 10-6.1. Removal/installation - motor generator brushes (1 of 2)

REMOVAL - ELEVATION OR TRAVERSE GENERATOR BRUSHES

1. REMOVE MOTOR GENERATOR FROM VEHICLE (FIG. 10-6)
2. REMOVE 4 SCREWS, FLAT WASHERS, LOCK WASHERS, AND END COVER (VIEW D).
3. REMOVE SCREW (4), WASHER (4) AND BRUSH LEAD (4) VIC. (E).
4. USE SMALL PIECE OF WIRE BENT TO J-HOOK TO RETRACT BRUSH HOLD-DOWN LEVER. REMOVE 4 BRUSHES.

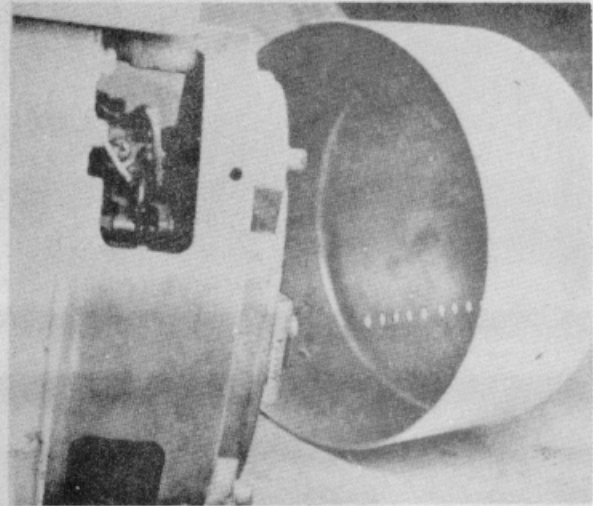

VIEW D

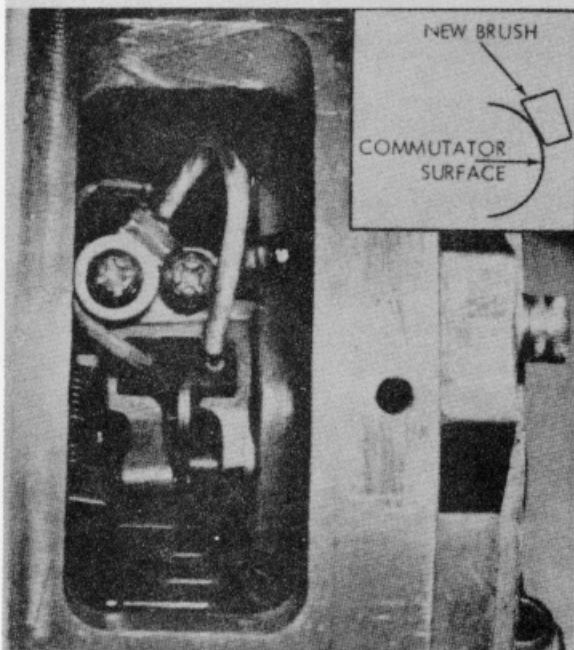

VIEW E

OTHER MAINTENANCE

ALL OTHER MAINTENANCE ON MOTOR GENERATOR IS PERFORMED BY SUPPORT MAINTENANCE. END BELL (VIEW F) IS FACTORY ADJUSTED FOR POLARITY BALANCE AND SHOULD NEVER REQUIRE READJUSTMENT.

INSTALLATION

1. REVERSE REMOVAL PROCEDURE.

**CAUTION:** BRUSHES MUST BE INSTALLED SO CHAMFER IS TANGENT TO COMMUTATOR SURFACE (INSET, VIEW E)

**NOTE:** EARLY DESIGN MOTOR GENERATOR HAS ONE ROW OF HOLES IN END COVER. COVER MUST BE INSTALLED WITH HOLES ACROSS BOTTOM OF COVER AS SHOWN IN VIEW D. (LATER DESIGN HAS HOLES IN SQUARE PATTERN, AND MAY BE INSTALLED IN ANY POSITION.)

2. NEW BRUSHES MUST BE RUN IN BY OPERATING GENERATOR UNTIL 75% OF BRUSH SURFACE IS IN CONTACT WITH COMMUTATOR SURFACE (INSET, VIEW F). RUN-IN TIME IS APPROXIMATELY 8 HOURS.

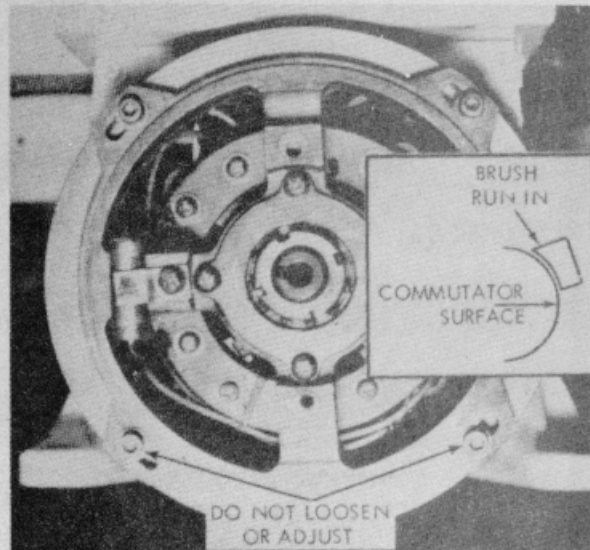

VIEW F

WE 12199

Figure 10-6.2. Removal/installation - motor generator brushes (2 of 2)

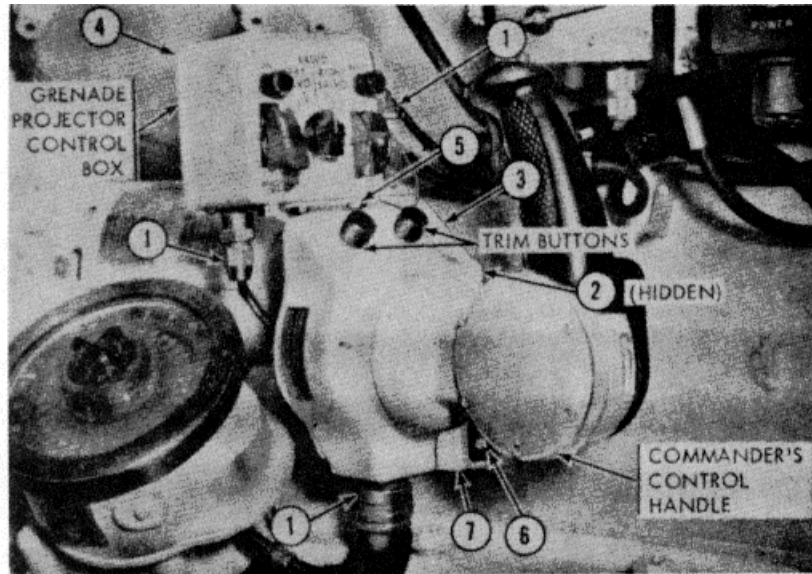

A. COMMANDER'S CONTROL HANDLE AND GRENADE PROJECTOR CONTROL BOX.

(REFER TO FIGURE 10-7.1 FOR DUAL MOUNTING POSITION)

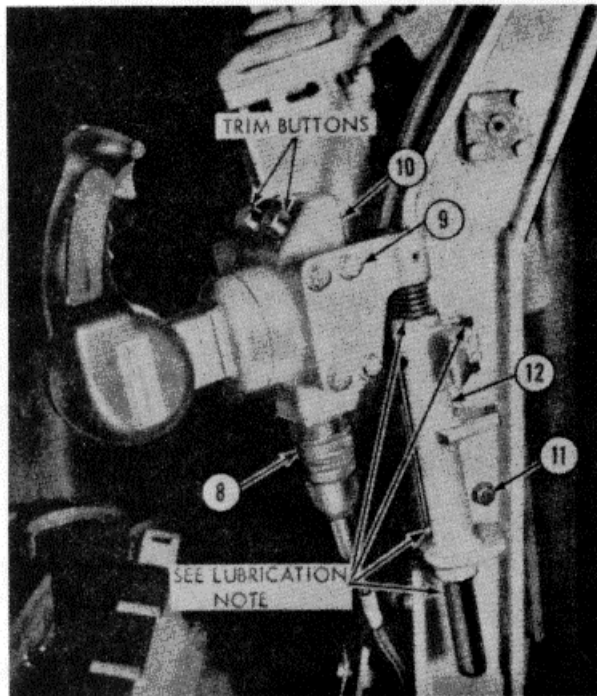

B. GUNNER'S CONTROL HANDLE.

PRELIMINARY STEP

TURN TURRET POWER AND VEHICLE MASTER SWITCHES OFF

REMOVAL

COMMANDER'S CONTROL HANDLE

1. ELECTRICAL CONNECTORS(4, 1 HIDDEN)
2. SCREW AND WASHER (4)
3. CONTROL HANDLE AND GRENADE LAUNCHER CONTROL BOX WITH BRACKET
4. SCREWS AND WASHERS (4) AND CONTROL BOX COVER
5. SCREWS, WASHERS AND NUTS (4) TO REMOVE CONTROL BOX FROM BRACKET.
6. SCREWS AND WASHERS (2).
7. MOUNTING BRACKET.

GUNNER'S CONTROL HANDLE

8. ELECTRICAL CONNECTOR (USE PLIERS 5120-624-8065).
9. SCREWS AND WASHERS (4).
10. CONTROL HANDLE.
11. SCREW AND WASHER.
12. CONTROL HANDLE BRACKET ASSEMBLY

INSTALLATION

REVERSE REMOVAL PROCEDURE. PERFORM TEST SET PROCEDURES, TABLE 10-3, FOR TRIM BUTTON ADJUSTMENTS ON BOTH CONTROL HANDLES.

LUBRICATION NOTE. LUBRICATE SHAFT, RELEASE LEVER, AND PIN SPARINGLY WITH LUBRICATING OIL PL-S (VV-L-800).

WE 12186

Figure 10-7. Removal/installation - commander's or gunner's control handle assembly, and grenade launcher control box

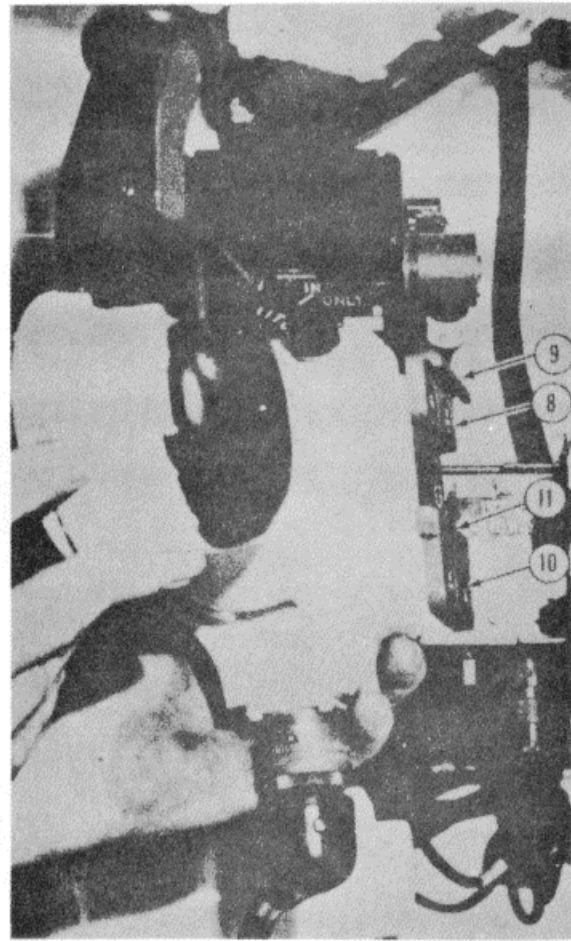
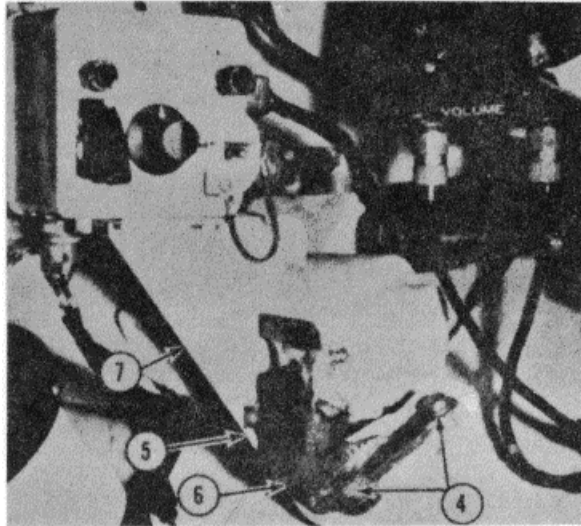
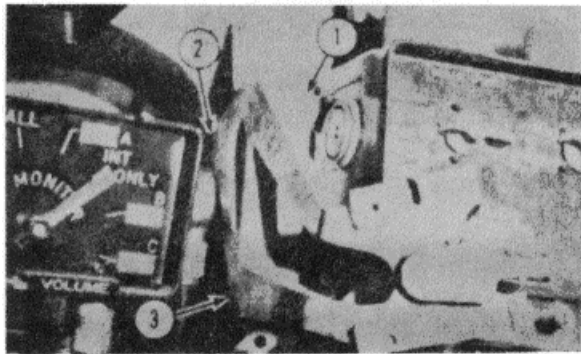

#### LEGEND

1. BOLT (2), NUT (2)
2. BOLT AND WASHER (HIDDEN)
3. UPPER BRACKET
4. SCREW (2), WASHER (2)
5. SCREW AND WASHER (HIDDEN)
6. LOWER BRACKET
7. GRENADE LAUNCHER CONTROL BOX BRACKET
8. SCREW (2)
9. BLOCK
10. SCREW (2)
11. PLATE

#### REMOVAL

REMOVE COMMANDER'S CONTROL HANDLE FROM BRACKET (FIG. 2-20.1).  
REPLACE UNSERVICEABLE PARTS AS REQUIRED.

#### INSTALLATION

REVERSE REMOVAL PROCEDURE.  
ITEMS 1, 8 AND 10: USE SEALANT 8030-081-2330.

**NOTE.** WHEN REPLACING COMMANDER'S CONTROL HANDLE, REMOVE BLOCK (9) AND PLATE (11) FROM OLD HANDLE AND INSTALL ON NEW HANDLE.

WE 12095

Figure 10-7.1. Removal/installation - commander's control handle dual position mounting brackets.

10-12.1  
(10-12.2 Blank)

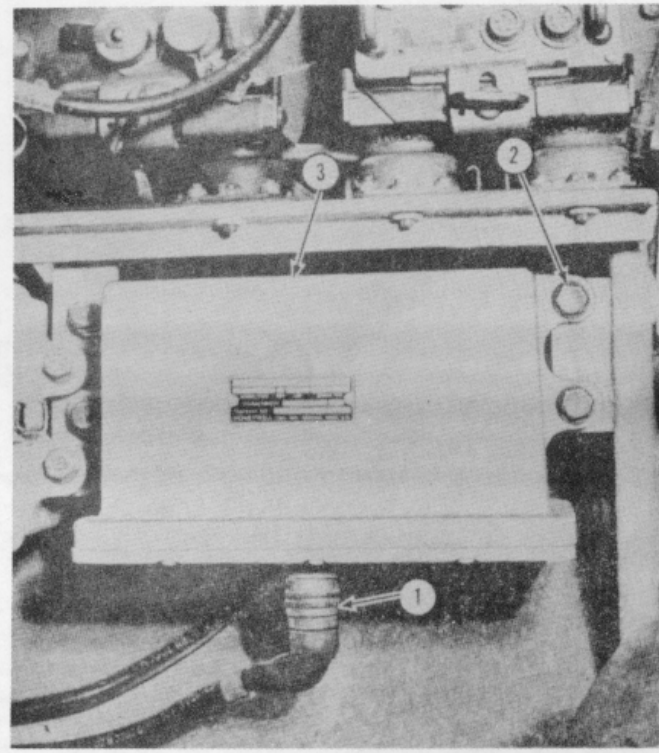

Figure 10-8. Removal/installation/test - power supply assembly

PRELIMINARY STEP

TURN TURRET POWER AND VEHICLE MASTER SWITCHES TO "OFF" POSITION.

REMOVAL

1. ELECTRICAL CONNECTOR  
(USE PLIERS - 5120-908-6339).
2. SCREWS AND WASHERS (4)
3. POWER SUPPLY ASSEMBLY

INSTALLATION

REVERSE REMOVAL PROCEDURE. PERFORM TEST SET SYSTEM CHECK (TABLE 10-3).

WE 11160

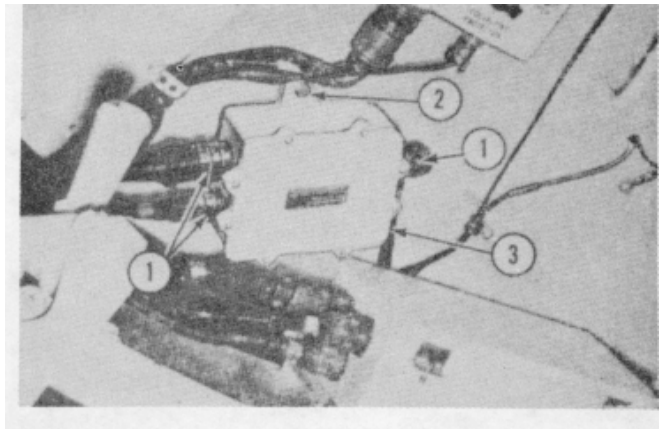

Figure 10-9. Removal/installation - gyro selector assembly

PRELIMINARY STEPS

TURN TURRET POWER AND VEHICLE MASTER SWITCHES TO "OFF" POSITION.

REMOVAL

1. ELECTRICAL CONNECTOR (3)  
(USE PLIERS- 5120-9086339)
2. SCREW AND WASHER (2)
3. GYRO SELECTOR

INSTALLATION

REVERSE REMOVAL PROCEDURE. PERFORM TEST SET SYSTEM CHECK (TABLE 10-3).

WE 11179



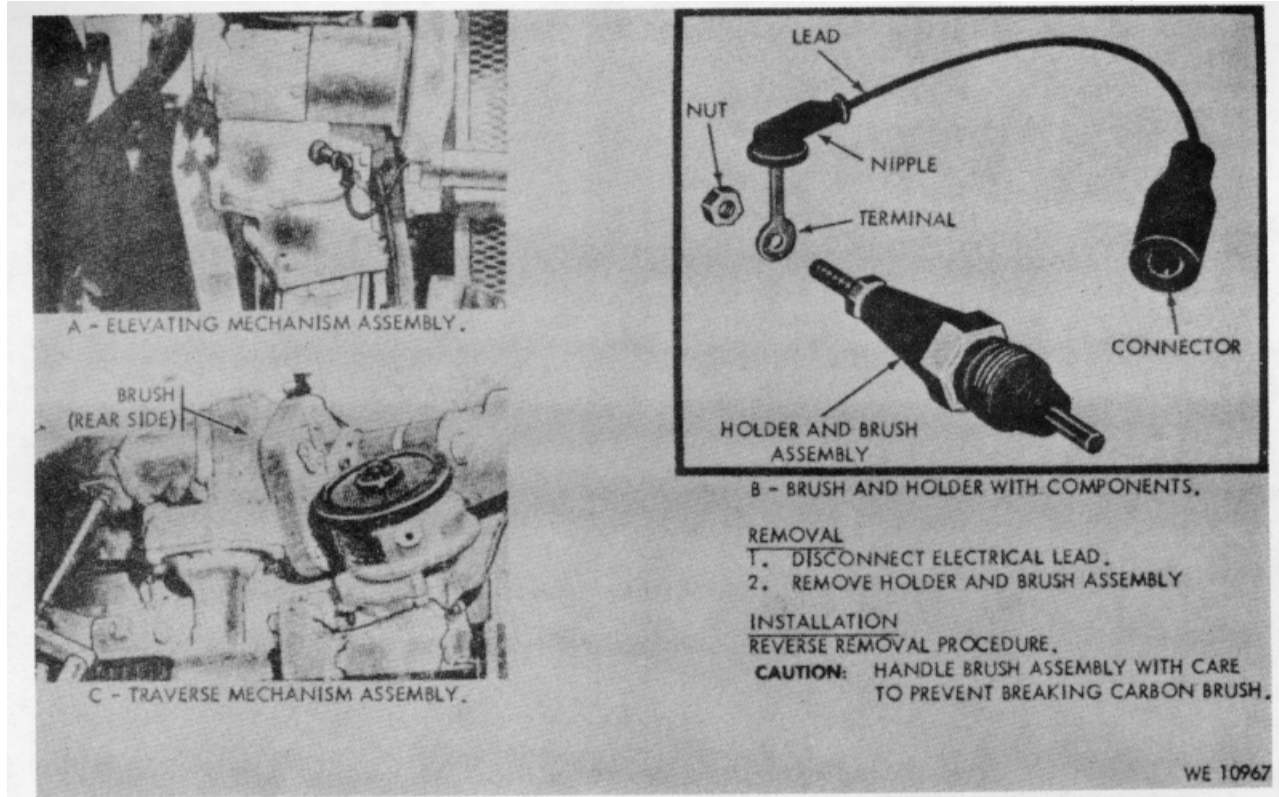

Figure 10-10. Removal/installation - elevating and traverse mechanism clutch brush

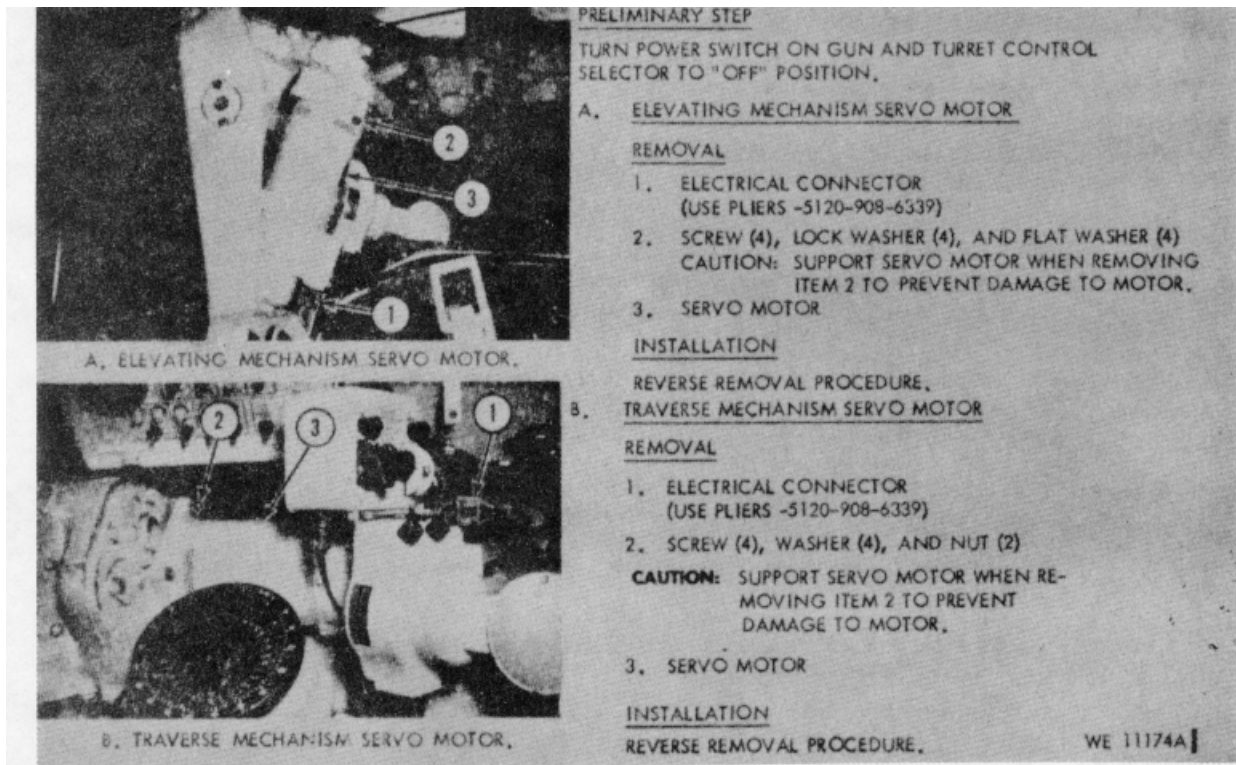
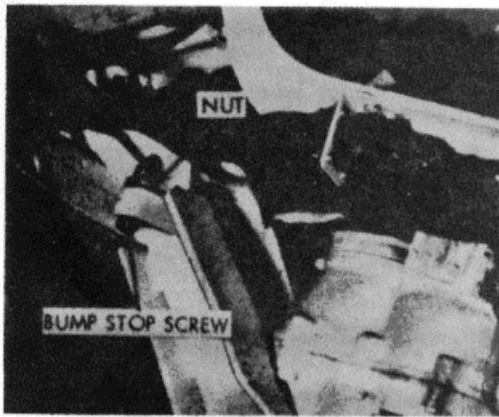
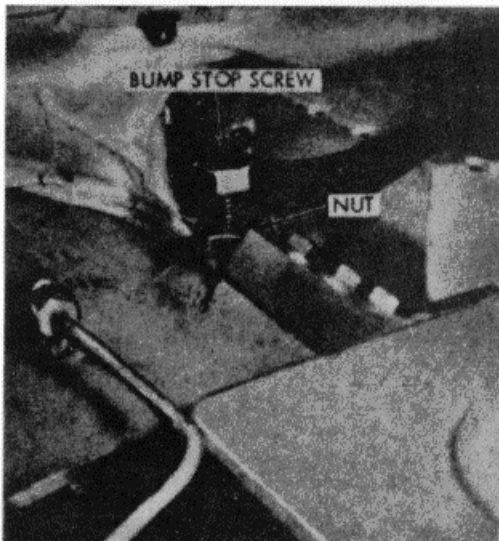

Figure 10-11. (Superseded) Removal/installation - elevating and traverse mechanism servo mo



A - GUN-LAUNCHER ELEVATION BUMP STOP



B - GUN-LAUNCHER DEPRESSION BUMP STOP.



C - GUN-LAUNCHER DEPRESSION CONTROL REFERENCE.

ADJUSTMENT

1. USE M1A1 QUADRANT TO LEVEL GUN.
2. ZERO M13A1 QUADRANT
3. SET OFF 336 MILS ELEVATION USING M13A1 QUADRANT, LOOSEN LOCK NUT ON ELEVATION BUMP STOP SCREW.
4. ADJUST ELEVATION BUMP STOP SCREW AT 336 MILS, TIGHTEN LOCK NUT.
5. SET OFF 142 MILS DEPRESSION. LOOSEN LOCK NUT.
6. ADJUST DEPRESSION BUMP STOP SCREW TO 142 MILS DEPRESSION, TIGHTEN LOCK NUT.

**CAUTION:** THE ELECTRICAL LIMIT SWITCHES MUST OPERATE 8 TO 10 MILS BEFORE GUN-LAUNCHER HITS THE MANUAL (METAL) BUMP STOPS. REFER TO SUPPORTING MAINTENANCE FOR CHECK AND ADJUSTMENT WHILE VEHICLE IS LEVEL.

DEPRESSION CONTROL - REFERENCE (VIEW C)

A MECHANICAL CONTROL IS PROVIDED TO LIMIT THE MANUAL DEPRESSION OF THE GUN OVER THE REAR DECK. IT ALSO PREVENTS MANUAL TRAVERSING GUN OVER REAR DECK WHEN BELOW 66 MILS DEPRESSION. SEE FIGURE 10-13 FOR ADJUSTMENT.

WE 10966

Figure 10-12. Adjusting gun-launcher elevation and depression bump stops

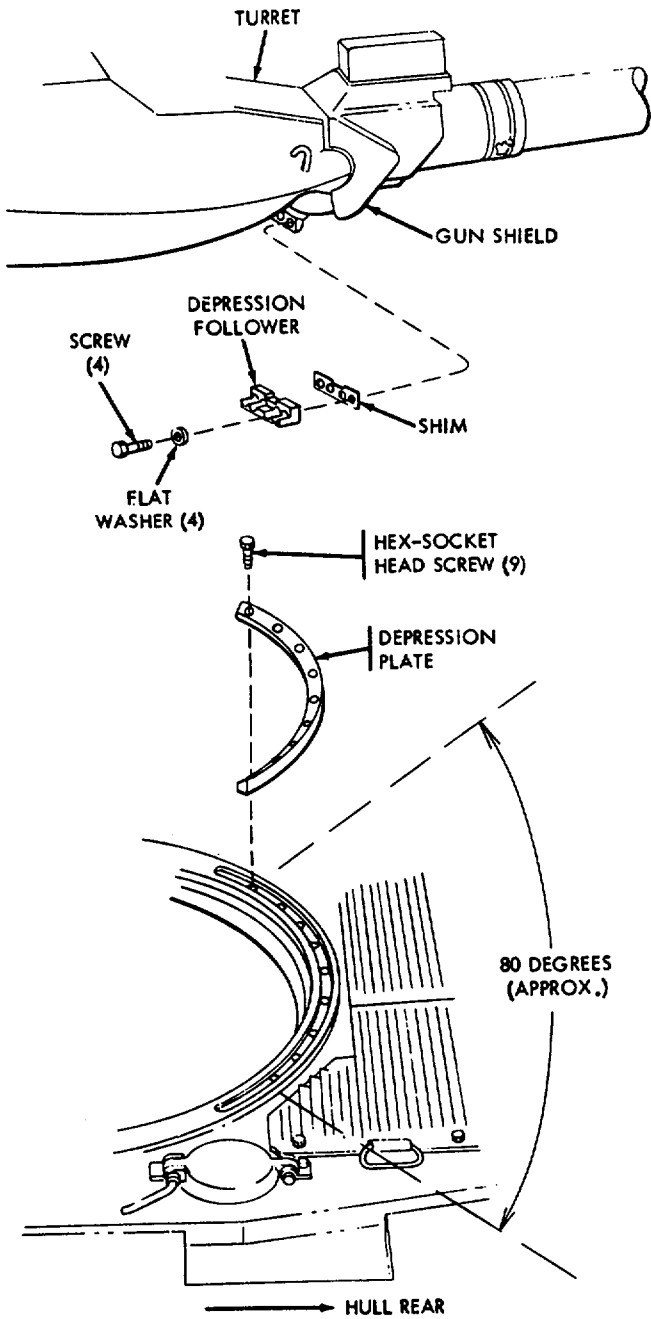

ADJUSTMENT - SHIM DEPRESSION FOLLOWER TO OBTAIN  $65 \pm 4$  MILS DEPRESSION WITH VEHICLE LEVEL.

NOTES

ALL COMPONENTS OF MECHANICAL LIMIT STOP MAY BE REMOVED WITH TURRET INSTALLED ON HULL. TURRET IS SHOWN REMOVED FOR CLARITY ONLY.

DURING MANUAL TRAVERSE OF TURRET, GUN DEPRESSION LIMIT IS ESTABLISHED AT 62.2 TO 70.3 MILS DEPRESSION IN APPROXIMATELY 80° TRAVEL OF TURRET AND GUN AT HULL REAR AND CONTROLLED BY LIMIT STOP GROUP AS SHOWN. SHIM AS REQUIRED TO LIMIT GUN DEPRESSION BETWEEN 62.2 TO 70.3 MILS DEPRESSION.

DURING REMAINING 280° MANUAL TRAVERSE OF TURRET AND GUN, DEPRESSION IS REGULATED AT 142 MILS DEPRESSION STOP SCREW ON TOP OF GUN MOUNT RECOIL MECHANISM.

DURING ELECTRICAL TRAVERSE OF TURRET, ELEVATION AND DEPRESSION IS AUTOMATICALLY CONTROLLED BY LIMIT SWITCHES. REFER TO SUPPORTING MAINTENANCE FOR ADJUSTMENT OF THESE SWITCHES.

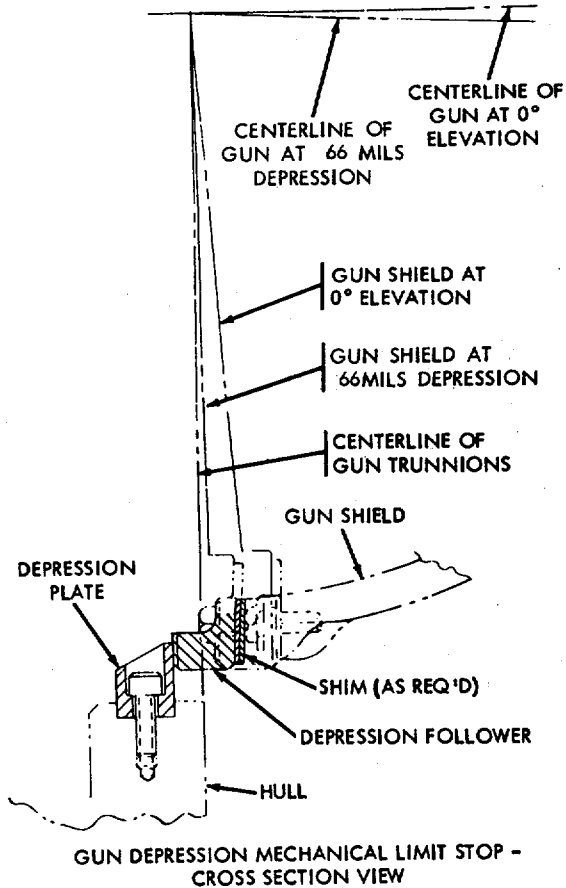

WE10965

Figure 10-13. Adjusting gun-launcher depression control



**Section 10-3. CONVENTIONAL WEAPONS DATA**

**10-3. General**

a. This section contains organizational maintenance instructions for the conventional weapons system components listed in table 10-4.

b. The following components are not part of, but have functional operation with turret conventional weapons system.

- (1) Azimuth indicator section 11-3 of chapter 11.
- (2) Gunner's or commander's control handle table 10-2.
- (3) Gun and turret control selector support maintenance.

c. Refer to figure 10-1 and table 10-1 for locational reference of conventional weapons system components.

ASSEMBLY OR COMPONENT	FIGURE REFERENCE		
	TEST	ADJUST	REMOVE/INSTALL
Relay Box			10-14
Breech Scavenge Repeat Switch			10-14
Loader's Control Box			10-14
Blasting Machine			10-16
120 Volt Firing Circuit Power Supply			10-16.1
Safe-to-fire Indicator Switch	3-2		

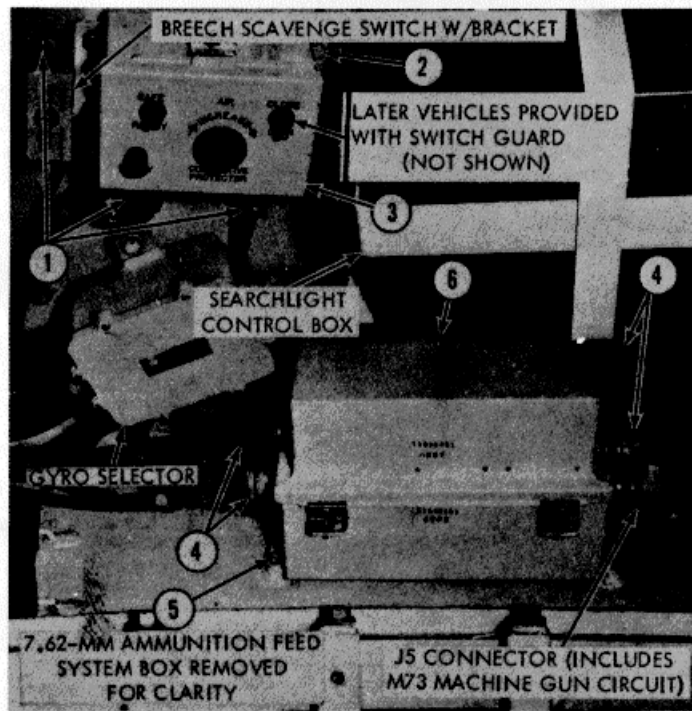

PRELIMINARY STEP

TURN OFF VEHICLE MASTER SWITCH AND ALL SWITCHES ON TURRET CONTROL SELECTOR.

REMOVAL - LOADER'S CONTROL BOX AND BREECH SCAVENGE SWITCH

- 1. ELECTRICAL CONNECTORS (4)  
(USE PLIERS - 5120-624-8065).
- 2. SCREWS AND WASHERS (4)
- 3. LOADER'S CONTROL BOX AND BREECH SCAVENGE SWITCH

REMOVAL - RELAY BOX

NOTE. ON VEHICLES EQUIPPED WITH SEARCHLIGHT CONTROL BOX, REMOVE GYRO SELECTOR (FIG. 10-9) TO ALLOW CLEARANCE FOR REMOVAL OF RELAY BOX.

- 4. ELECTRICAL CONNECTORS (7)  
(USE PLIERS - 5120-624-8065)
- 5. SCREWS AND WASHERS (4)
- 6. RELAY BOX

INSTALLATION

REVERSE REMOVAL PROCEDURE. MAKE SURE MATCHING MOUNTING SURFACES ARE CLEAN TO BARE METAL. COAT ALL MOUNTING HARDWARE WITH MOISTURE RESISTANT VARNISH - 5970-840-7494 AFTER INSTALLATION.

WE 12153

Figure 10-14. Removal/installation - relay box and loader's control box.

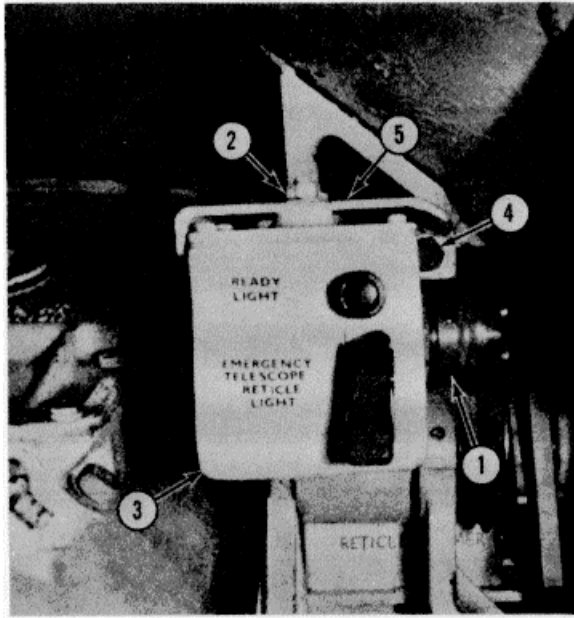

**REMOVAL**

1. ELECTRICAL CONNECTOR.  
( USE PLIERS-5120-624-8065)
2. NUTS (2) AND WASHERS (2).
3. POWER SUPPLY BATTERY BOX.
4. SCREWS (2) AND WASHERS (4).
5. BRACKET.

**INSTALLATION**

REVERSE REMOVAL PROCEDURE, MAKE SURE MATCHING MOUNTING SURFACES ARE CLEAN TO BARE METAL. COAT ALL MOUNTING HARDWARE WITH MOISTURE RESISTANT VARNISH 5970-840-7494 AFTER INSTALLATION.

WE 12163

Figure 10-15. Removal/installation - M119 or #127 telescope emergency power supply battery box

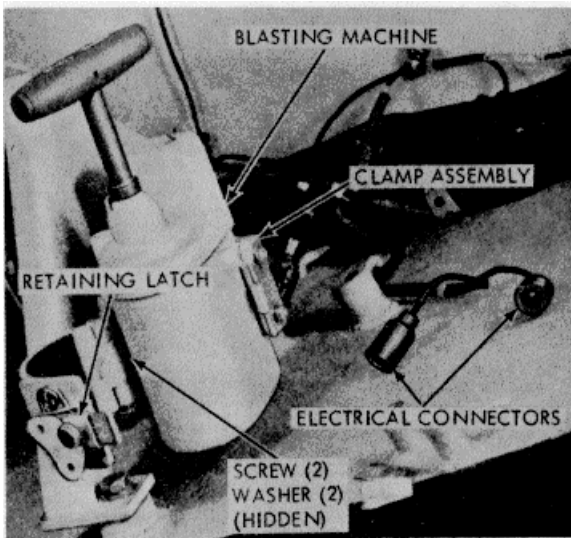

**REMOVAL**

1. DISCONNECT ELECTRICAL CONNECTORS.
2. RELEASE RETAINING LATCH.
3. REMOVE BLASTING MACHINE.
4. REMOVE 2 SCREWS AND WASHERS.
5. REMOVE BRACKET ASSEMBLY.

**INSTALLATION**

REVERSE REMOVAL PROCEDURE.

**LEGEND**

1. BLASTING MACHINE
2. SLEEVE
3. CABLE
4. SLEEVE
5. SAFETY PIN

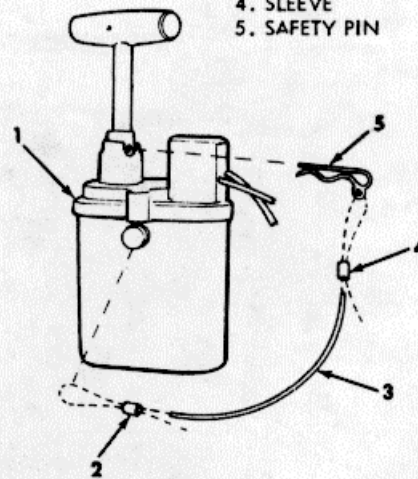

**REPAIR OF SAFETY DEVICE**

REPLACE UNSERVICEABLE PARTS AS REQUIRED. CRIMP SLEEVES ON DOUBLED CABLE TO FORM LOOPS.

WE 66618 I

Figure 10-16. Removal/installation - gun-launcher blasting machine (impulse generator).

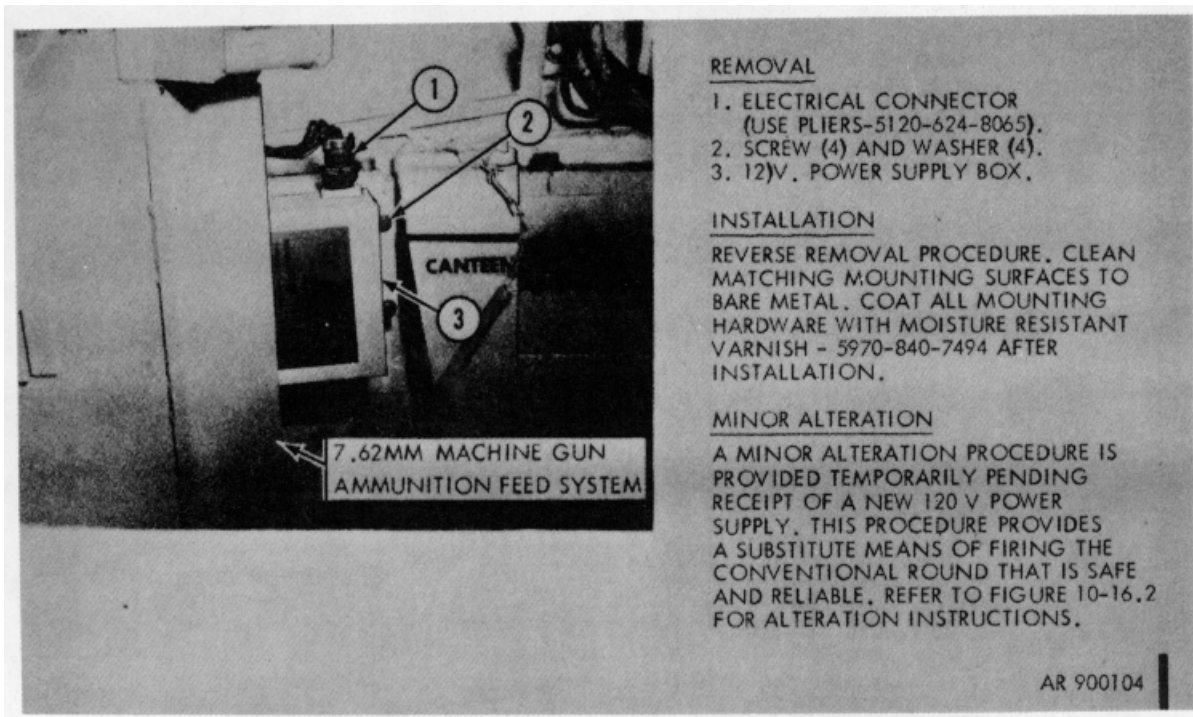

Figure 10-16.1. Removal/installation - unserviceable 120 volt dc firing circuit power supply.

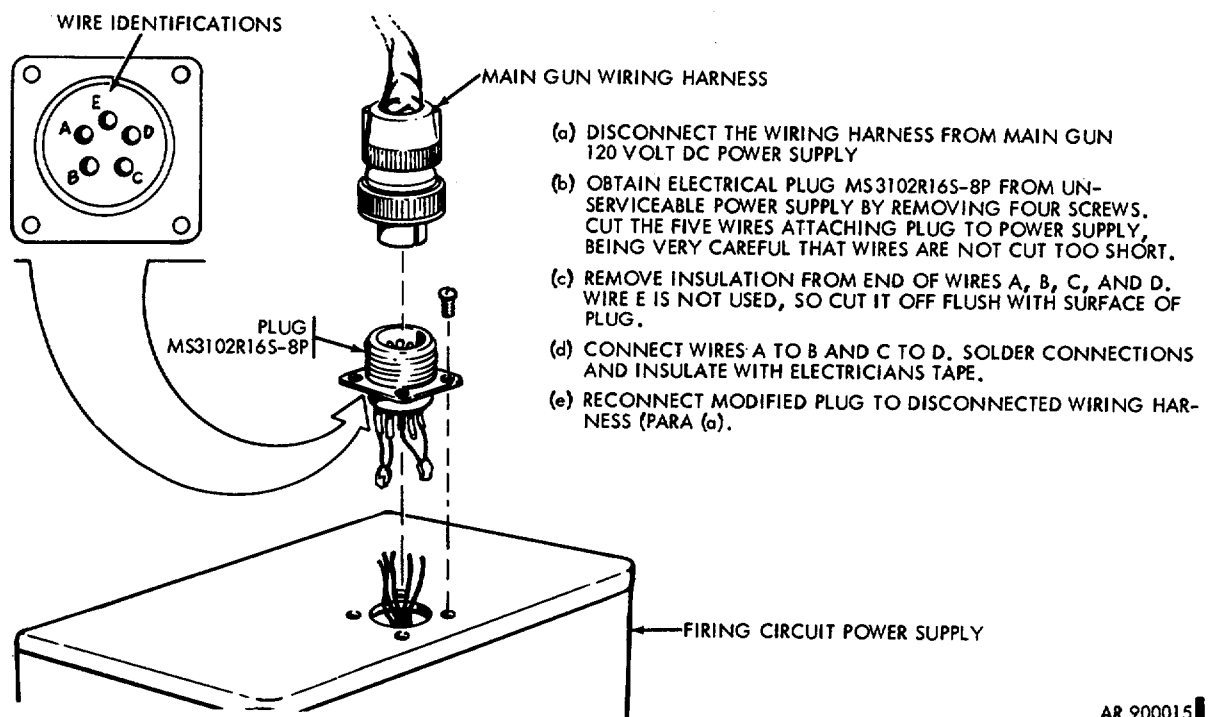

Figure 10-16.2. Minor alteration of unserviceable 120 volt dc firing circuit power supply.

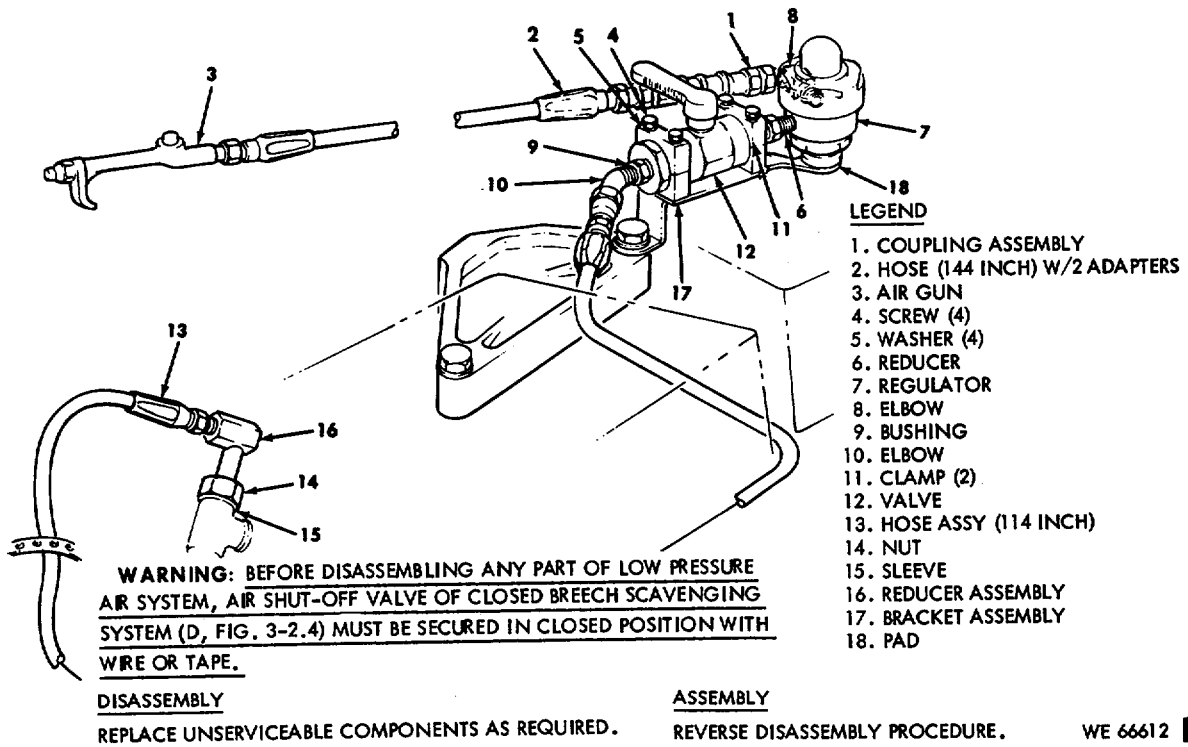

Figure 10-17. Disassembly/assembly - low pressure air radiator cleaning system.

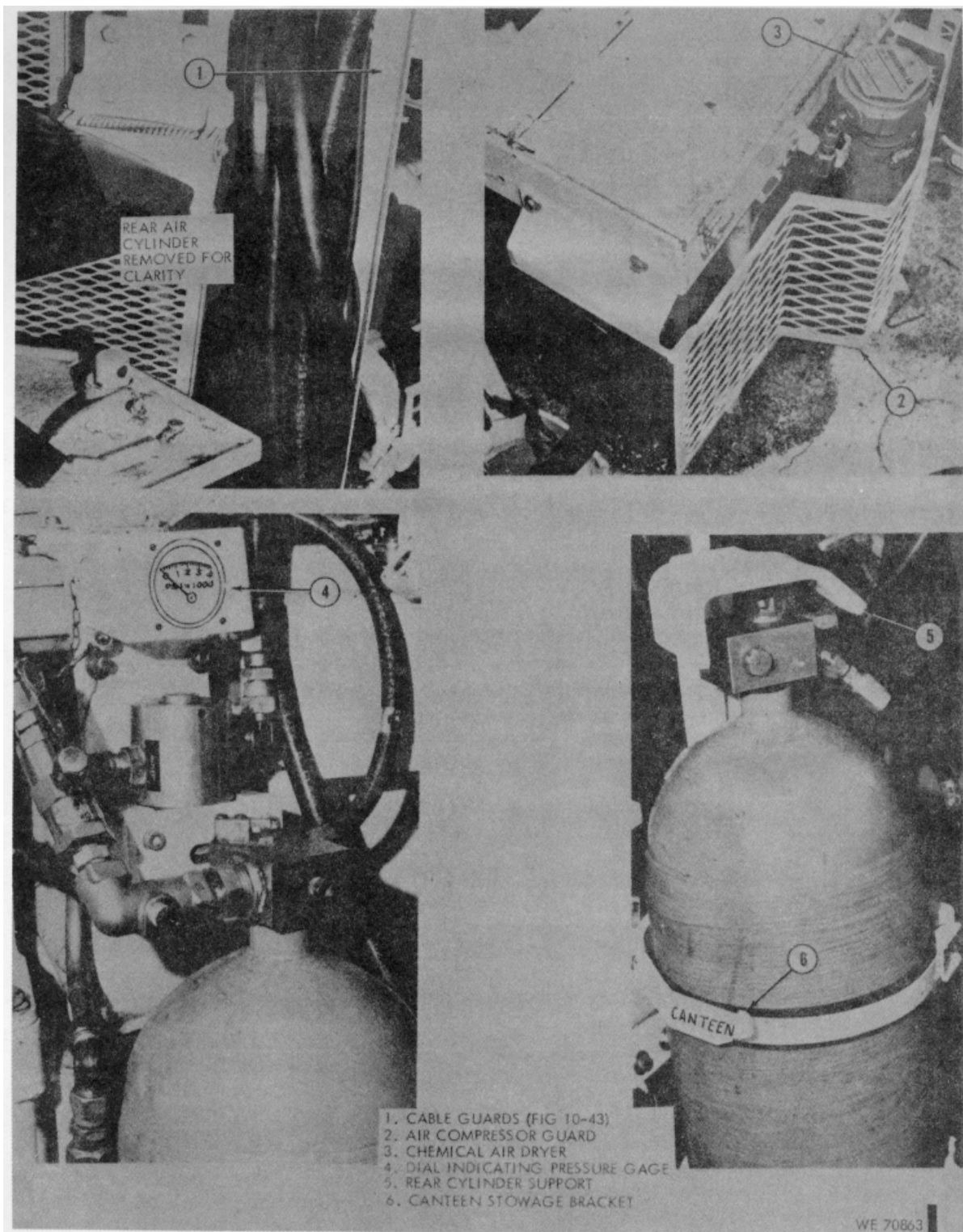
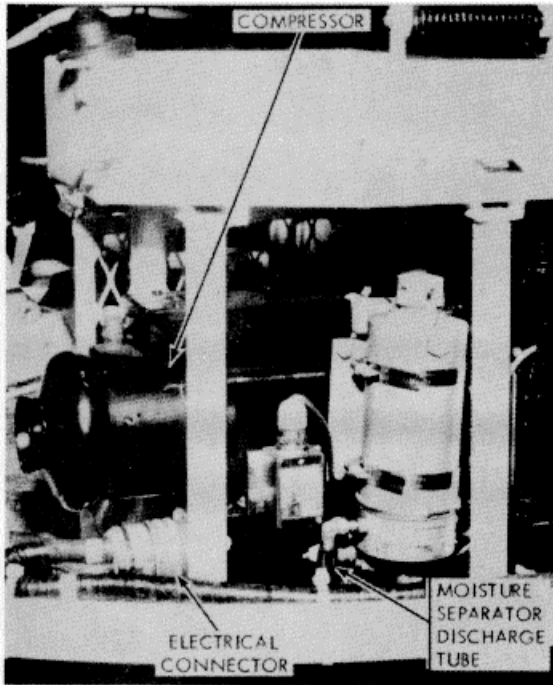
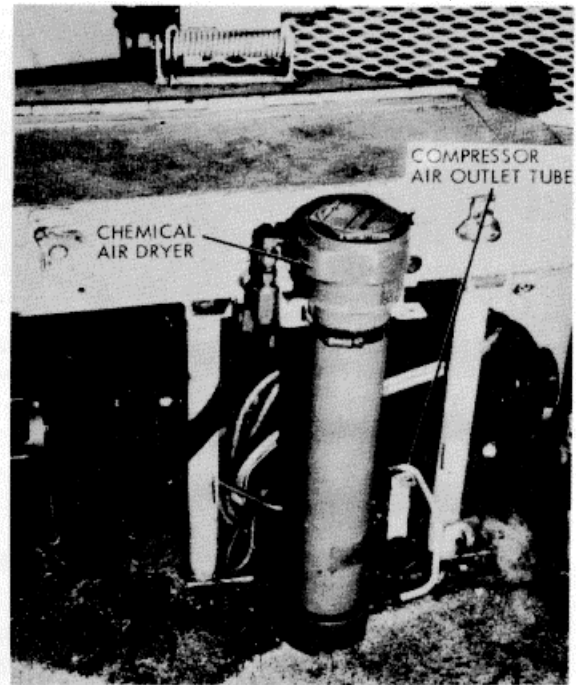

Figure 10-17.0. Identification and location of guards and CBSS parts.

(10-18.4 blank)/10-18.3



VIEW A



VIEW B

NOTE: COMPRESSOR GUARD  
REMOVED

#### PRELIMINARY STEPS

- A. ASSURE THAT COMPRESSOR SWITCH ON LOADER'S CONTROL BOX IS IN "OFF" POSITION.
- B. REMOVE COMPRESSOR GUARD AND AIR DRYER.
- C. BLEED AIR PRESSURE FROM SYSTEM (FIG. 4-2).
- D. TRAVERSE TURRET SO COMPRESSOR FACES DRIVER'S COMPARTMENT.

#### REMOVAL

1. DISCONNECT ELECTRICAL CONNECTOR FROM COMPRESSOR.  
NOTE: WHEN REPLACEMENT OF COMPRESSOR IS REQUIRED, MAKE SURE TO REMOVE NIPPLE MS 24392-J4 FROM OLD COMPRESSOR AND RETAIN FOR INSTALLATION IN NEW COMPRESSOR.
2. DISCONNECT MOISTURE SEPARATOR DISCHARGE TUBE FROM COMPRESSOR.
3. DISCONNECT AIR OUTLET TUBE FROM COMPRESSOR AND PLUG TUBE OPENING
4. REMOVE 4 COMPRESSOR MOUNTING SCREWS AND WASHERS.
5. REMOVE COMPRESSOR (COMPRESSOR WEIGHS 52 POUNDS, USE SUITABLE LIFTING DEVICE).

#### INSTALLATION

**CAUTION:** PRIOR TO INSTALLING COMPRESSOR 4310-460-2184, 4310-181-8895, OR 4310-196-1617, PLACE FIBER GLASS GASKET 5330-152-3361 BETWEEN COMPRESSOR MOUNTING BASE AND TURRET FLOOR TO PREVENT ELECTRICAL SHORTING.

REVERSE REMOVAL PROCEDURE.  
INSTALLATION NOTES.

- A. INSPECT CLAMPS AND STRAPS ON ELECTRICAL CABLE TO MAKE SURE CABLE ROUTING REMAINS UNCHANGED.
- B. TIGHTEN AIR TUBE SECURELY TO COMPRESSOR.
- C. TIGHTEN COMPRESSOR MOUNTING SCREWS TO 35 POUNDS-FEET.
- D. LEAK-TEST ALL DISTURBED AIR CONNECTIONS WITH LIQUID SOAP.

**CAUTION:** AVOID DAMAGING AIR CYLINDERS WHICH ARE UNDER VERY HIGH PRESSURE.

WE 73808

Figure 10-17.1. Removal/installation - breech scavenging compressor



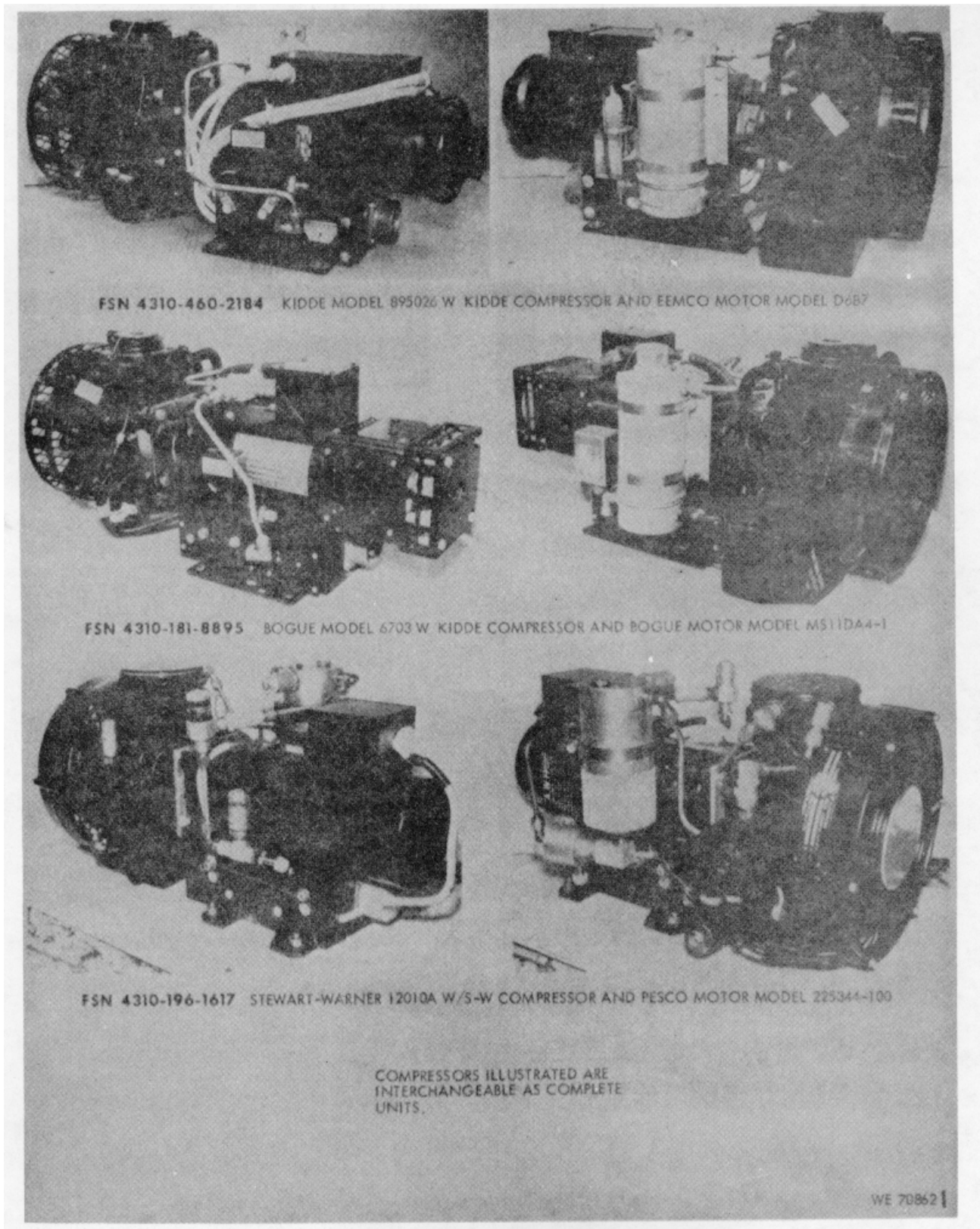
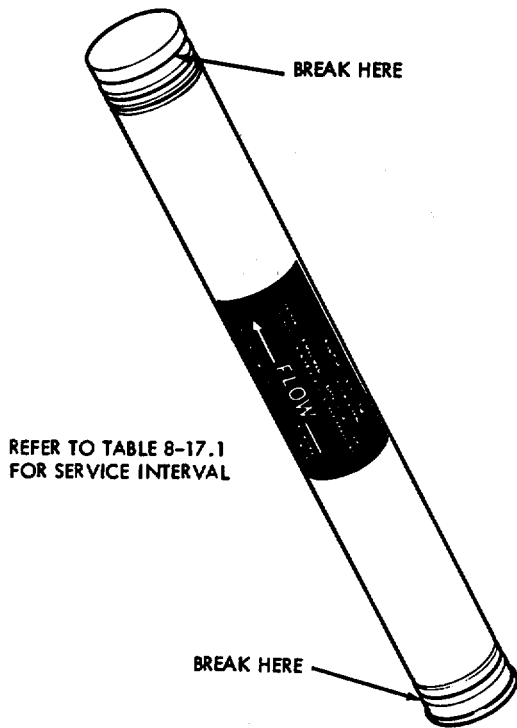

Figure 10-17.1.1. Compressor identification

Figure 10-17. 2 - deleted.



**PRELIMINARY STEP**

BLEED MOISTURE FROM CYLINDERS AND BLEED AIR PRESSURE FROM SYSTEM (FIG. 4-2).

**REMOVAL**

1. REMOVE PLUG FROM TOP OF AIR DRIER HOUSING (USE SOCKET WRENCH FSN 5120-189-7916).
2. REMOVE AND DISCARD USED CARTRIDGE.

**INSTALLATION**

1. BREAK TIPS OFF OF NEW CARTRIDGE BEFORE INSTALLING.
2. INSTALL CARTRIDGE WITH ARROW POINTING UPWARD.
3. REMOVE, CLEAN, AND INSPECT PREFORMED PACKING. REPLACE PACKING IF DEFORMED OR DETERIORATED.
4. CLEAN PLUG AND CAVITY BEFORE INSTALLING PREFORMED PACKING. LIGHTLY LUBRICATE PACKING BEFORE INSTALLATION.
5. INSTALL PLUG AND TIGHTEN TO 220-260 POUNDS-INCH.
6. PRESSURIZE SYSTEM (1200 PSI MINIMUM) AND LEAK-TEST WITH LIQUID SOAP.

WE 66570

Figure 10-17.3. Removal/installation - chemical air drier cartridge



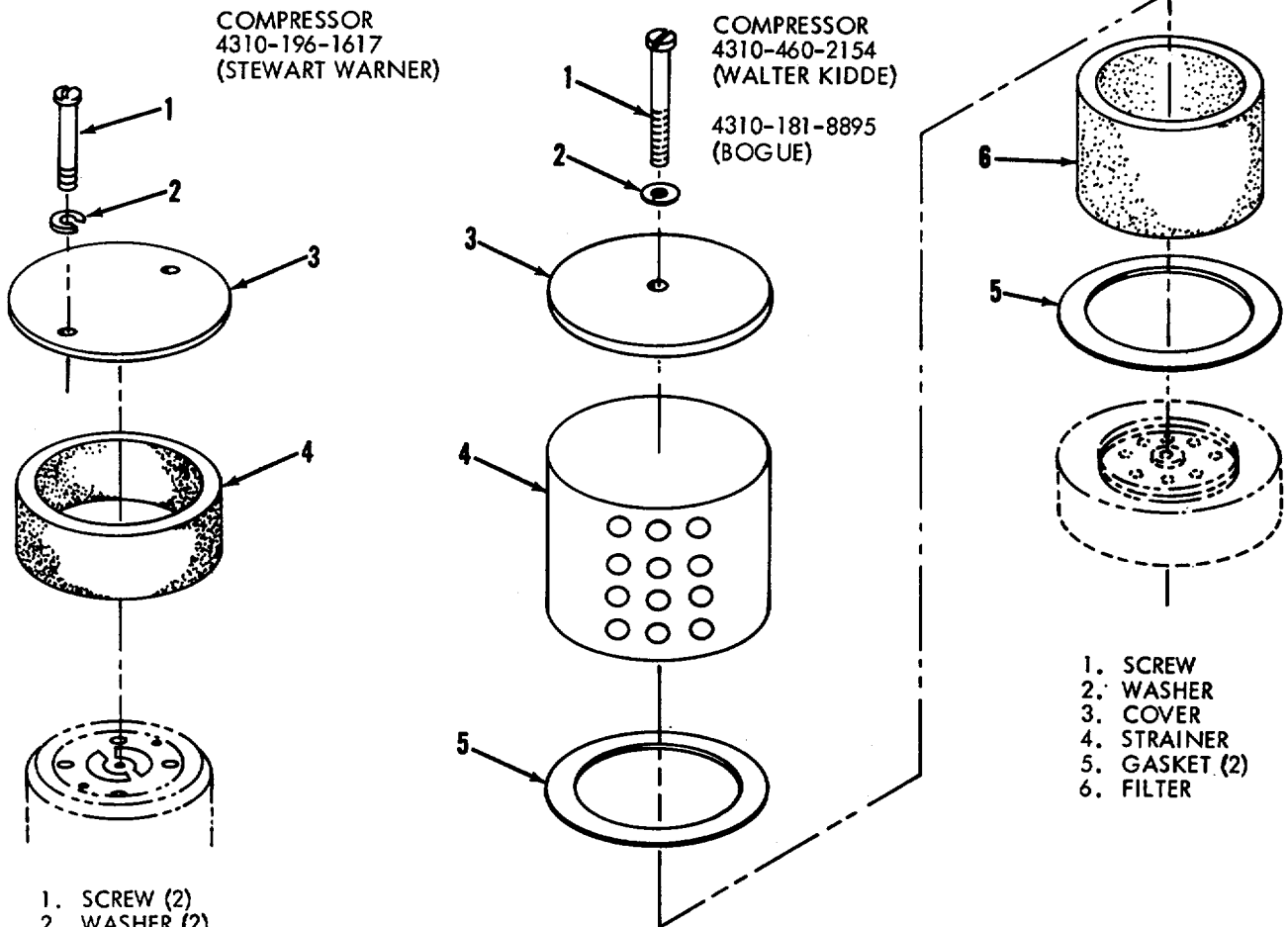

- 1. SCREW (2)
- 2. WASHER (2)
- 3. COVER
- 4. FILTER

**CLEANING**

USING TPM, CLEAN COVER AND FILTER. ON WALTER KIDDE AND BOGUE COMPRESSORS ALSO CLEAN INNER AND OUTER GASKETS AND STRAINER. DRY WITH COMPRESSED AIR.

**INSTALLATION**

REVERSE REMOVAL PROCEDURE.  
REFER TO TABLE 8-17.1 FOR SERVICING INTERVAL.

**REMOVAL**

TOP OF COMPRESSOR IS ACCESSIBLE THROUGH HOLE IN ODDMENT. FOLLOW NUMERICAL SEQUENCE.

WE 70013

Figure 10-17. 4. Removal/cleaning/installation - compressor air intake strainer and filter.

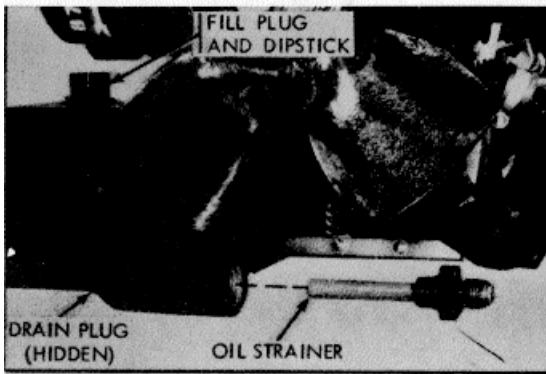

#### DIPSTICK REMOVAL/INSTALLATION

TURN COUNTERCLOCKWISE TO REMOVE FILL PLUG/DIPSTICK FROM OIL SUMP. TIGHTEN SECURELY AT INSTALLATION.

#### OIL STRAINER REMOVAL

1. REMOVE COMPRESSOR FROM VEHICLE (FIG. 10-17.1).
2. REMOVE FILL PLUG.
3. REMOVE DRAIN PLUG AND DRAIN OIL FROM COMPRESSOR. ALLOW APPROXIMATELY 5 MINUTES TO PERMIT OIL LINES TO DRAIN COMPLETELY.
4. REMOVE 4 SCREWS, WASHERS, AND FAN GUARD.
5. DISCONNECT OIL LINE AT OIL PUMP AND OIL STRAINER AND REMOVE LINE.
6. TURN OIL STRAINER COUNTERCLOCKWISE TO REMOVE.



#### CLEANING OIL STRAINER

CLEAN WITH TPM AND DRY WITH COMPRESSED AIR. IF EXCESSIVE FOREIGN MATERIAL IS EVIDENT ON STRAINER OR IN STRAINER CAVITY, FLUSH AS FOLLOWS: INSTALL DRAIN PLUG, TILT COMPRESSOR TOWARD STRAINER CAVITY, AND POUR DIESEL FUEL INTO FILL OPENING OF SUMP. DRY SUMP THOROUGHLY WITH COMPRESSED AIR APPLIED THROUGH FILL OPENING.

#### OIL STRAINER INSTALLATION

REVERSE REMOVAL PROCEDURE, STEPS 6 THROUGH 3. FILL SUMP WITH LUBRICATING OIL 9150-753-4667. CAPACITIES OF COMPRESSORS (FIG. 10-17.1.1) IS AS FOLLOWS:

4310-460-2184	----	4/5 PINT
4310-181-8895	----	4/5 PINT
4310-196-1617	----	1 PINT

#### CAUTION:

1. USE EXTREME CARE TO PREVENT OIL CONTAMINATION.
2. USE ONLY AIR COMPRESSOR LUBRICATING OIL, FSN 9150-753-4667.

WE 70032

Figure 10-17.5. Removal/installation - dipstick and oil strainer

**Section 10-4. MISSILE SUBSYSTEM**

**10-4. General**

a. This section contains instructions for organizational maintenance of the missile subsystem as listed in table 10-5.

b. Refer to figure 10-1 and table 10-1 for identification and locational reference of components of the subsystem.

**10-5. Checks and Adjustments**

a. General. Perform subsystem checkout procedures outlined in table 2-12 before making checks and adjustments to components of the subsystem. The transmitter alignment check will be performed quarterly or whenever alignment becomes questionable for any reason.

b. Transmitter Alignment Check. The transmitter alignment check procedure insures that the transmitter sees the same target image as the telescope missile reticle. To check transmitter alignment use transmitter alignment test set M45 (4935-999-2187) or M45A1 (4935-045-9864) and proceed as follows:

- (1) Perform subsystem checkout procedures (table 2-12) to make sure a GO

condition exists before proceeding with transmitter alignment check.

- (2) Set vehicle master switch to ON position. Turn selector on gun and turret control panel to MISSILE position.

**WARNING:** Make certain weapons are unloaded or deactivated and POWER selector on panel is in OFF position to prevent injury to personnel during performance of transmitter alignment check. Do not look into transmitter lens, eye damage may result.

- (3) Open transmitter door and install telescopic viewer with swivel clip of range measuring cord to lower eye hook of telescopic viewer thumb screw (fig. 10-20).
- (4) Attach adapter plate to external end of gunner's telescope mount.
- (5) Move downrange until measuring cord is taut. When using the M45Altest set, pivot the target board so that it and the stake are in vertical alignment. Position target board in socket on test set carrying case cover.

*Table 10-5. Missile Subsystem Components*

Assembly or Component	Figure Reference	
	Check	Replace
Cable Assembly Interconnection Diagram		10-18
Signal Data Converter		10-19
Modulator		10-19
Infrared Transmitter Cover and Door Latch and Control Assemblies (Refer to para 10-17. 2 for adjustments)		10-21
Infrared Transmitter (Refer to para 10-5 for alignment check)	10-20, 10-20.1	10-22
Subsystem Power Supply		10-23
Rate Sensing Unit		10-24
Remote Control Components Test Set		10-25
Infrared Tracker		10-26

- (6) Using manual elevating and traversing handles, place missile reticle of gunner's telescope over center of target board (fig. 10-20). When using the M45A1 test set, place the missile reticle of the gunner's telescope over the center of the upper target on the target board as shown in figure 10-20.1.

**CAUTION:** When sighting through telescopic viewer do not rest weight on transmitter, or gun shield.

- (7) Sight through telescopic viewer and determine whether center of target board is within the 6-milliradian circle of the viewer (fig. 10-20 and 10-20.1) If center of target board is not inside the 6-milliradian circle, replace transmitter. Should replacement transmitter give the same result, refer to support maintenance.
- (8) Remove adapter plate and telescopic viewer from vehicle. Wind up measuring cord on target board and stow all equipment in carrying case. Close transmitter door.

#### 10-6. Removal and Installation

Procedures illustrated in this section list the proper steps to be followed when removing and installing components of the missile subsystem. Refer to figure 10-1 and table 10-1 for location of the items in the turret.

#### 10-7. Cable Assemblies

When removal and replacement of a unit suspected of being defective does not correct a NO/GO situation, the cable assemblies to the unit may be at fault. Examine cable assemblies (fig. 10-18) to the unit for loose, broken, or incomplete connections. Repeat subsystem checkout procedures (table 2-12). If the NO/GO condition still exists, notify support maintenance personnel.

##### 10-7.1. Installation of RFI Filters

a. RFI filters 8035602 and 8035603 will be issued to all units. These filters must be installed on the optical tracker as specified below. When the vehicle is removed from service, the filters must be removed and installed on the replacement vehicle.

- (1) Disconnect W6P2 and W5P2 at the tracker.

**CAUTION:** Do not damage the connector pins. Exercise care when installing the filters and when connecting W6P2 and W5P2.

- (2) Install filter 8035602 on connector 2J1 and filters 8035603 on connector 2J2.
- (3) Connect W6P2 to filter 8035603 (2J2) and W5P2 to filter 8035602 (2J1).

b. Perform system self test (table 2-12) to insure the missile system is in a "GO" condition.

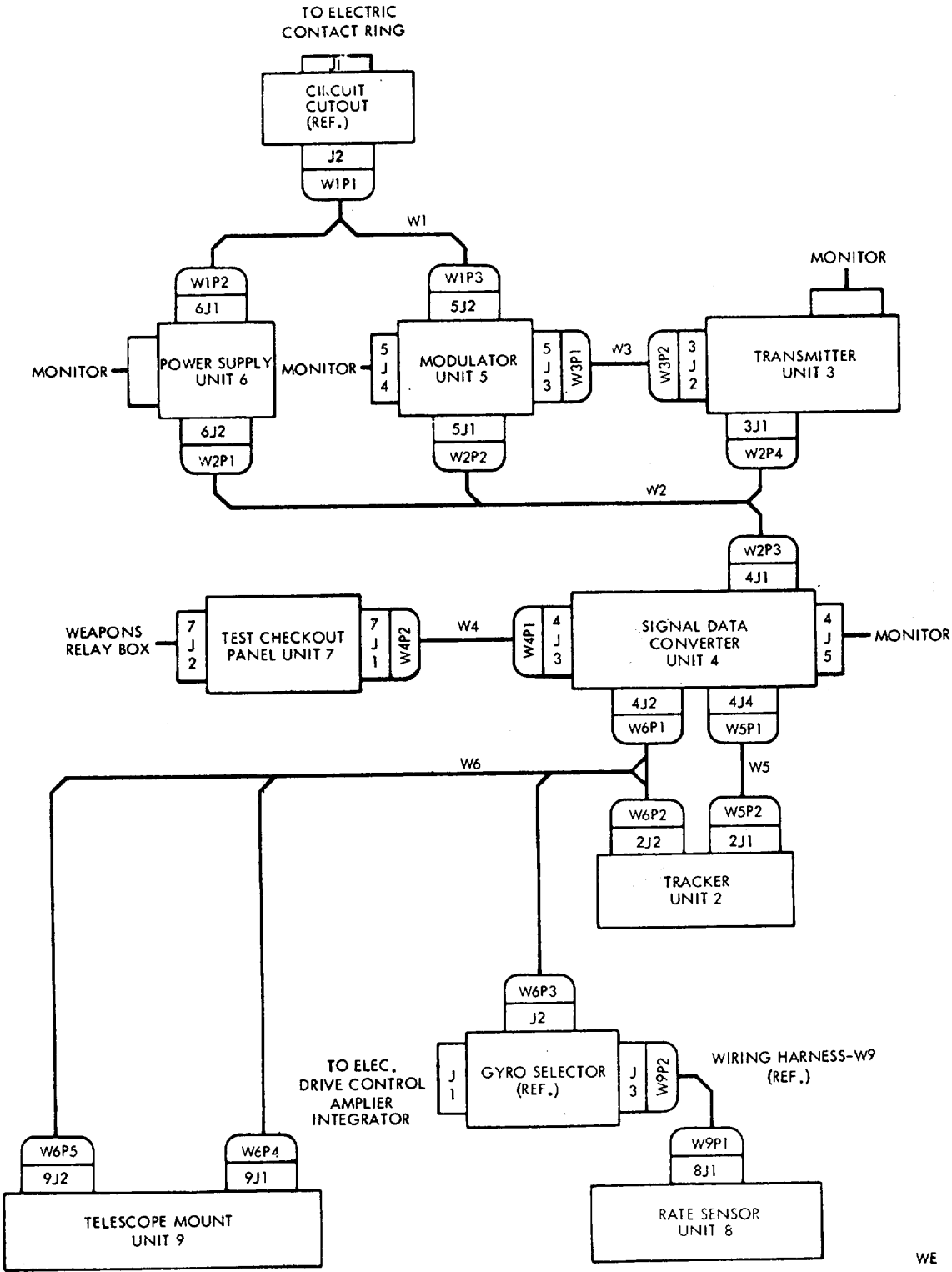

WE 11189

Figure 10-18. Missile subsystem cable assembly interconnection diagram

PRELIMINARY STEP

MAKE SURE VEHICLE MASTER SWITCH IS TURNED OFF.

REMOVAL - SIGNAL DATA CONVERTER

FOLLOW NUMERICAL SEQUENCE.

1. ELECTRICAL CONNECTORS (4) (USE PLIERS -5120-624-8065)
2. SELF - LOCKING BOLT (4)
3. FLAT WASHER (4)
4. SIGNAL DATA CONVERTER

CAUTION: TWO MEN ARE REQUIRED TO SUPPORT AND REMOVE SIGNAL DATA CONVERTER.

INSTALLATION

REVERSE REMOVAL PROCEDURE. MAKE SURE MATCHING MOUNTING SURFACES ARE CLEAN TO BARE METAL. TEST FOR PROPER OPERATION (TABLE 2-12).

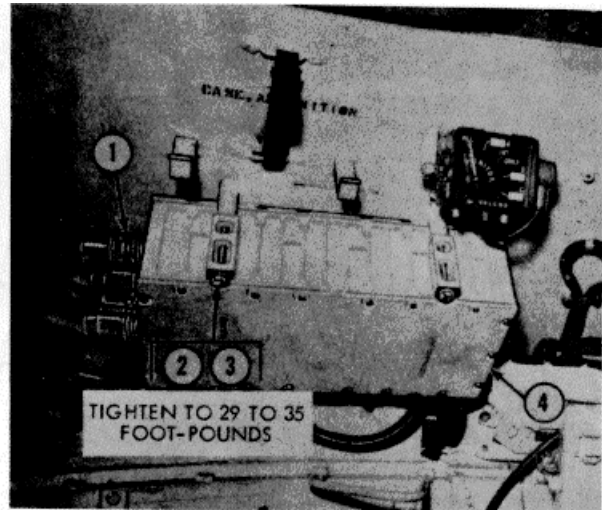
REMOVAL - MODULATOR

FOLLOW NUMERICAL SEQUENCE.

1. REMOVE 2 SCREWS, WASHERS AND BINOCULAR BRACKET
2. REMOVE BLASTING MACHINE (FIG. 10-16)
3. ELECTRICAL CONNECTORS (3) (USE PLIERS 5120-624-8065)
4. SELF - LOCKING BOLT (4)
5. FLAT WASHERS (4)
6. MODULATOR

INSTALLATION

REVERSE REMOVAL PROCEDURE. MAKE SURE MATCHING MOUNTING SURFACES ARE CLEAN TO BARE METAL. TEST FOR PROPER OPERATION (TABLE 2-12).

NOTE. COAT ALL MOUNTING HARDWARE WITH MOISTURE RESISTANT VARNISH 5970-840-7494 AFTER INSTALLATION.

WE 70029 |

Figure 10-19. Removal/Installation - signal data converter and modulator  
10-23

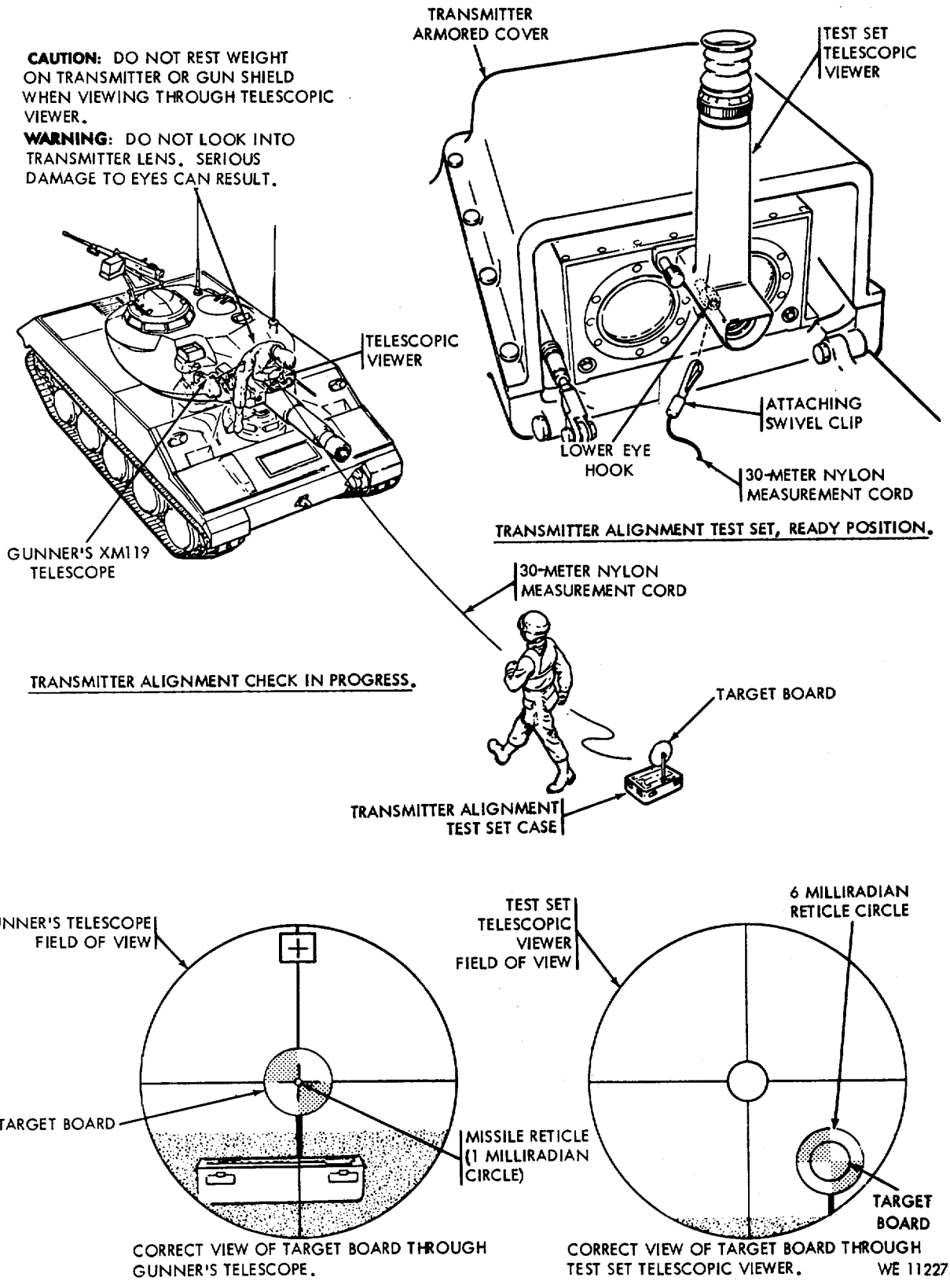
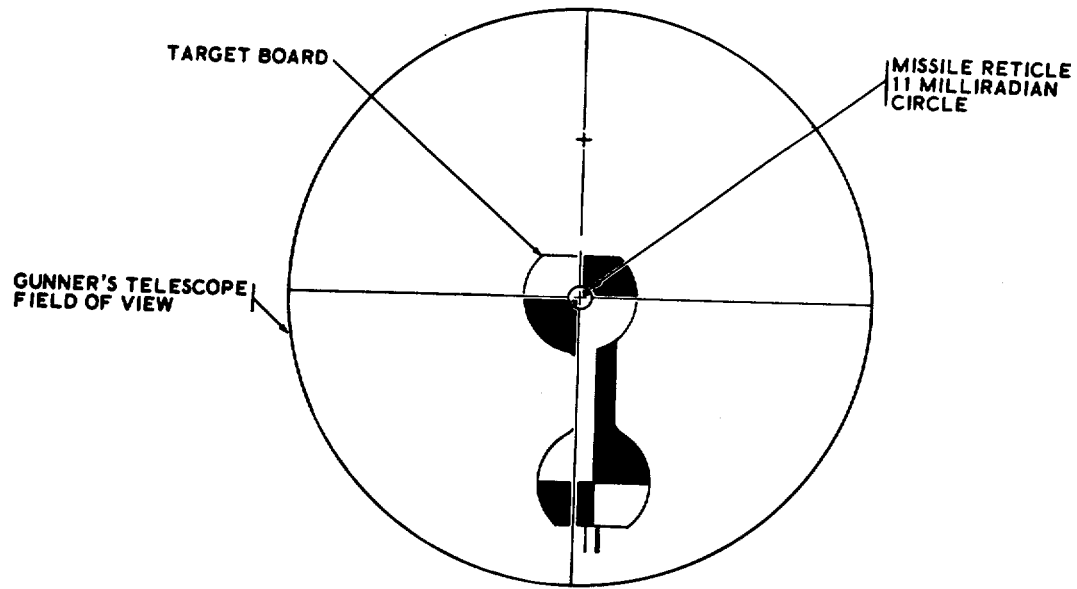
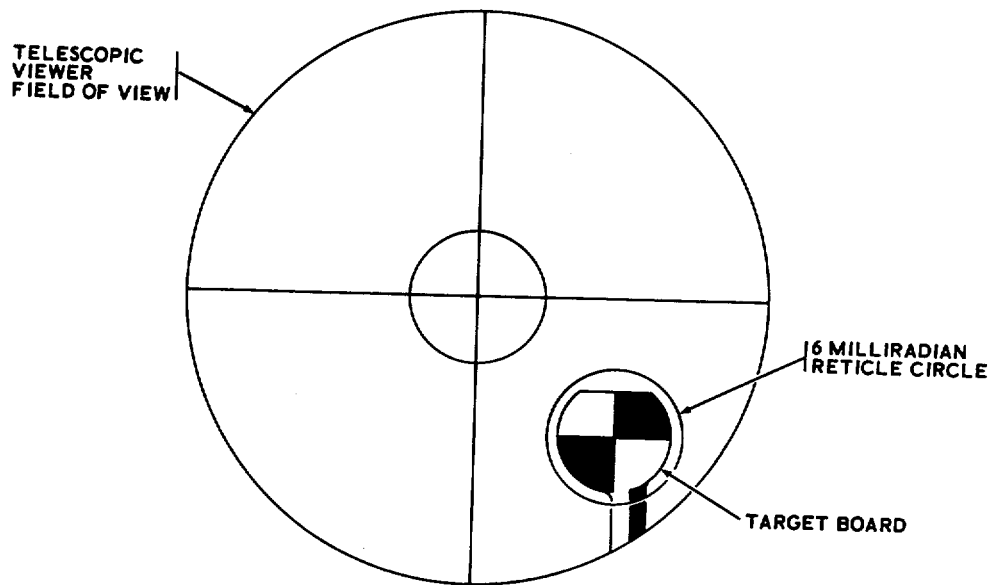

Figure 10-20. Transmitter alignment check



CORRECT VIEW OF TARGET BOARD THROUGH VEHICLE TELESCOPE



CORRECT VIEW OF TARGET BOARD THROUGH TELESCOPIC VIEWER

WE 66551

Figure 10-20.1. Transmitter alignment with M45A1 test set



Figure 10-20. 2 - deleted.

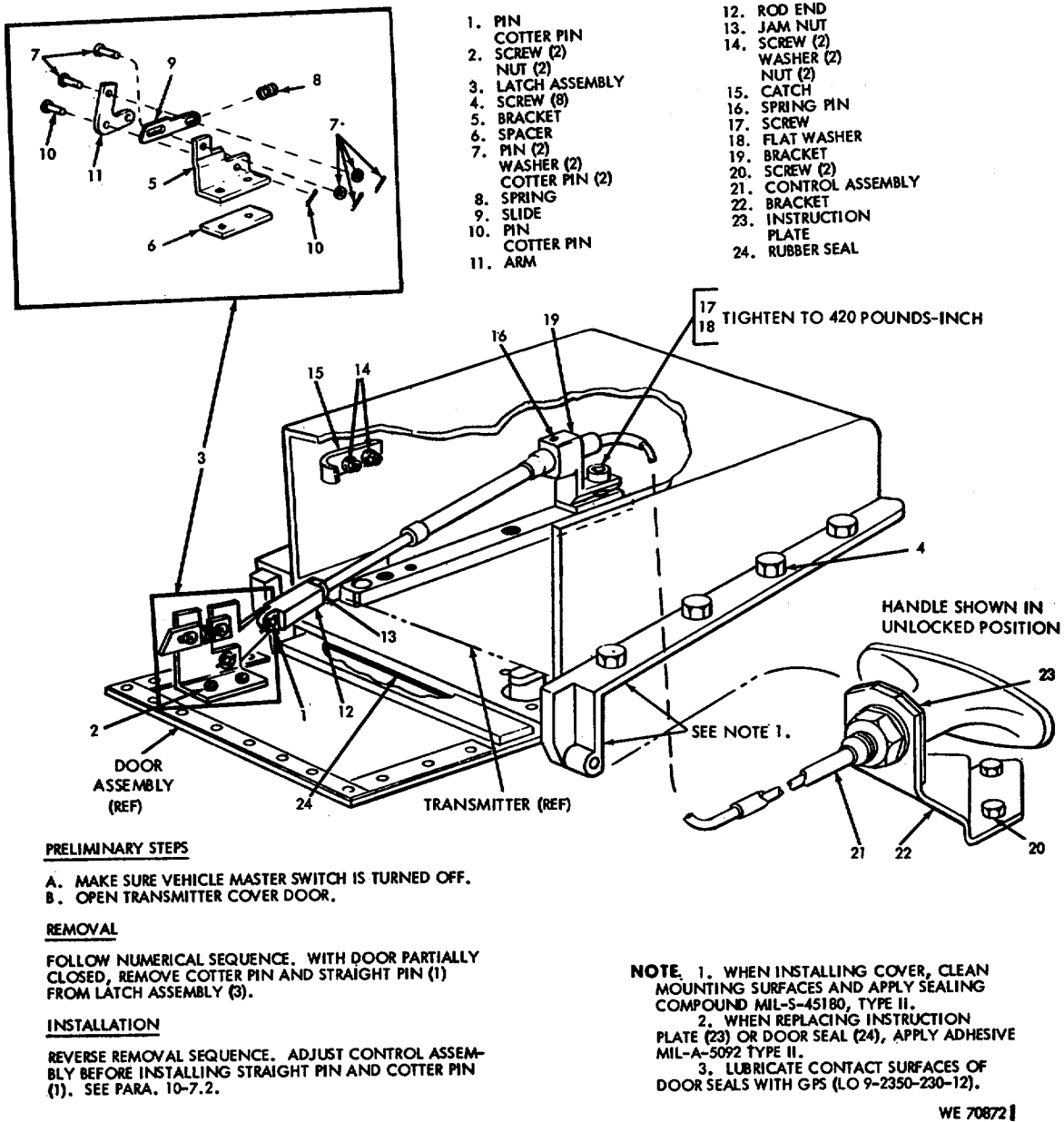

Figure 10-21. Removal/installation - infrared transmitter cover and disassembly/assembly of door latch and control assemblies.

10-7.2. Adjustment of Control Assembly and Door Catch

a. Cable Length Adjustment (Fig 10-21).

(1) Push handle of control assembly (21) in against bracket (22) and turn 90° either direction.

(2) Hold door in maximum open position and adjust rod end (12) to align with hole in door latch assembly (3).

(3) Turn rod end counterclockwise one or one and one-half turns to provide tension; tighten nut (13) against rod end.

(4) Secure rod end to latch assembly with straight pin and cotter pin (1).

b. Door Catch (Fig 10-21).

NOTE. Test adjustment of catch by closing door with handle, leaving handle in unlocked position. Attempt to pull door open.

(1) If door remains tight against cover, catch (15) adjustment is correct. Tighten nuts (14) 9 to 10 foot-pounds.

(2) If door will not open, but is not held tightly against cover, move catch back (approximately the distance catch permits door to open). Repeat test until door latches tightly against cover. Tighten nuts (14) 9 to 10 foot-pounds.

(3) If door opens, latch did not engage catch. Move catch forward and tighten nuts. Repeat test until door latches tightly against cover. Tighten nuts (14) 9 to 10 foot-pounds.

(c). Final Adjustment. After completing cable length adjustment and door catch adjustments (a and b above), open and close door with handle several times to assure proper operation. Then adjust door switch (fig 10-22).

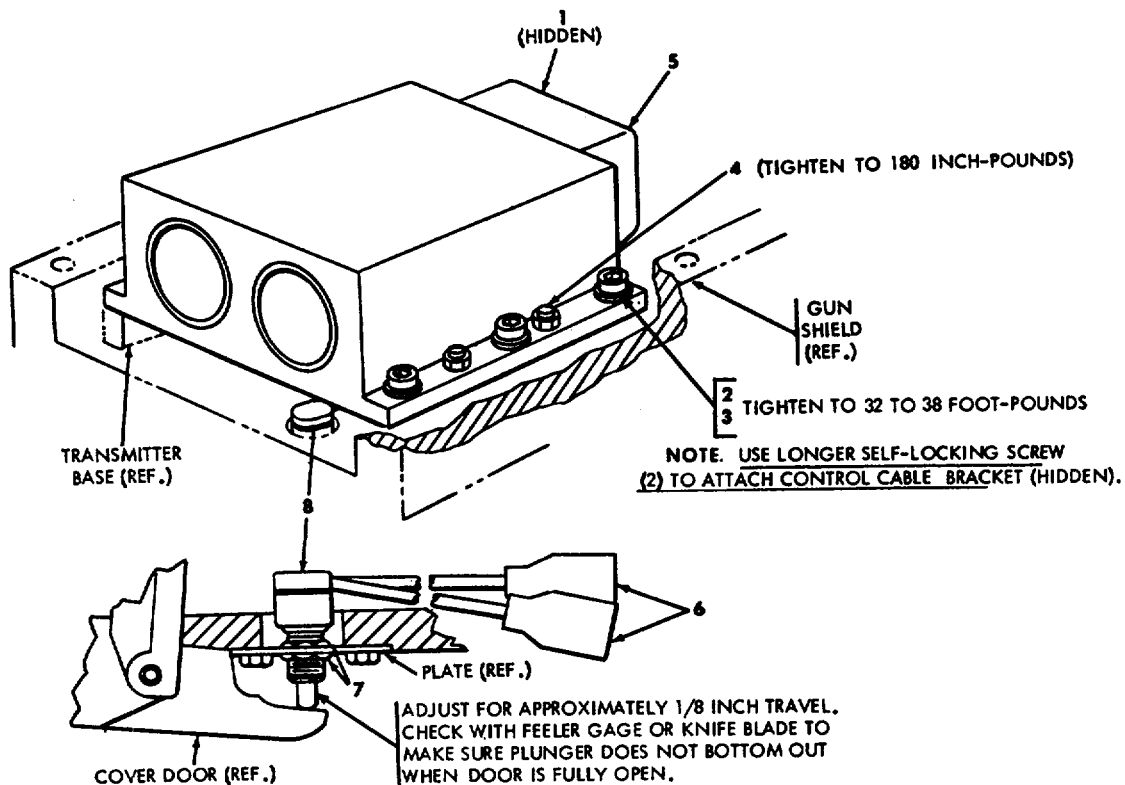

#### PRELIMINARY STEPS

- A. MAKE SURE VEHICLE MASTER SWITCH IS TURNED OFF.
- B. REMOVE TRANSMITTER COVER (FIG. 10-21).

#### REMOVAL

FOLLOW NUMERICAL SEQUENCE. DO NOT REMOVE PUSH SWITCH (ITEMS 6, 7, AND 8) UNLESS DEFECTIVE.

1. CABLE CONNECTORS (USE PLIERS - 5120-624-8065)
2. SELF-LOCKING SCREW(6)(FIVE 1 INCH LONG, ONE 1-1/2 INCH LONG)(USE SOCKET 5120-243-1674)
3. FLAT WASHER (6)
4. ALIGNMENT BOLT (4) (USE SOCKET 5120-596-0934)
5. TRANSMITTER
6. ELECTRICAL LEADS
7. JAM NUT
8. PUSH SWITCH

#### INSTALLATION

1. INSTALL PUSH SWITCH (ITEMS 6, 7, AND 8), IF REMOVED, AND ADJUST (SEE BELOW).
2. REMOVE FINISH FROM MOUNTING SURFACES AND REVERSE REMOVAL PROCEDURE.
3. COAT MOUNTING HARDWARE WITH MOISTURE RESISTANT VARNISH 5970-840-7494 AND ALIGNMENT BOLTS (ITEM 4) WITH SEALING COMPOUND - 8030-964-9222.
4. CHECK OUT AND ALIGN TRANSMITTER AFTER INSTALLATION (FIG. 10-20 AND TABLE 2-12).

#### PUSH SWITCH ADJUSTMENT

1. REPLACE COVER ASSEMBLY (FIG. 10-21) WITHOUT SEALER OR DOOR CLEVIS. TIGHTEN MOUNTING SCREWS FINGER TIGHT.
2. INSTALL SWITCH (ITEM 8) IN PLATE AND ADJUST JAM NUTS TO ALLOW 1/8 INCH TRAVEL OF SWITCH PLUNGER WHEN COVER IS OPENED TO MAXIMUM POSITION. TIGHTEN LOWER JAM NUT.
3. CONNECT ELECTRICAL LEADS (ITEM 6) AND REMOVE COVER ASSEMBLY.

WE 70029

Figure 10-22. Removal/installation - infrared transmitter and door switch.

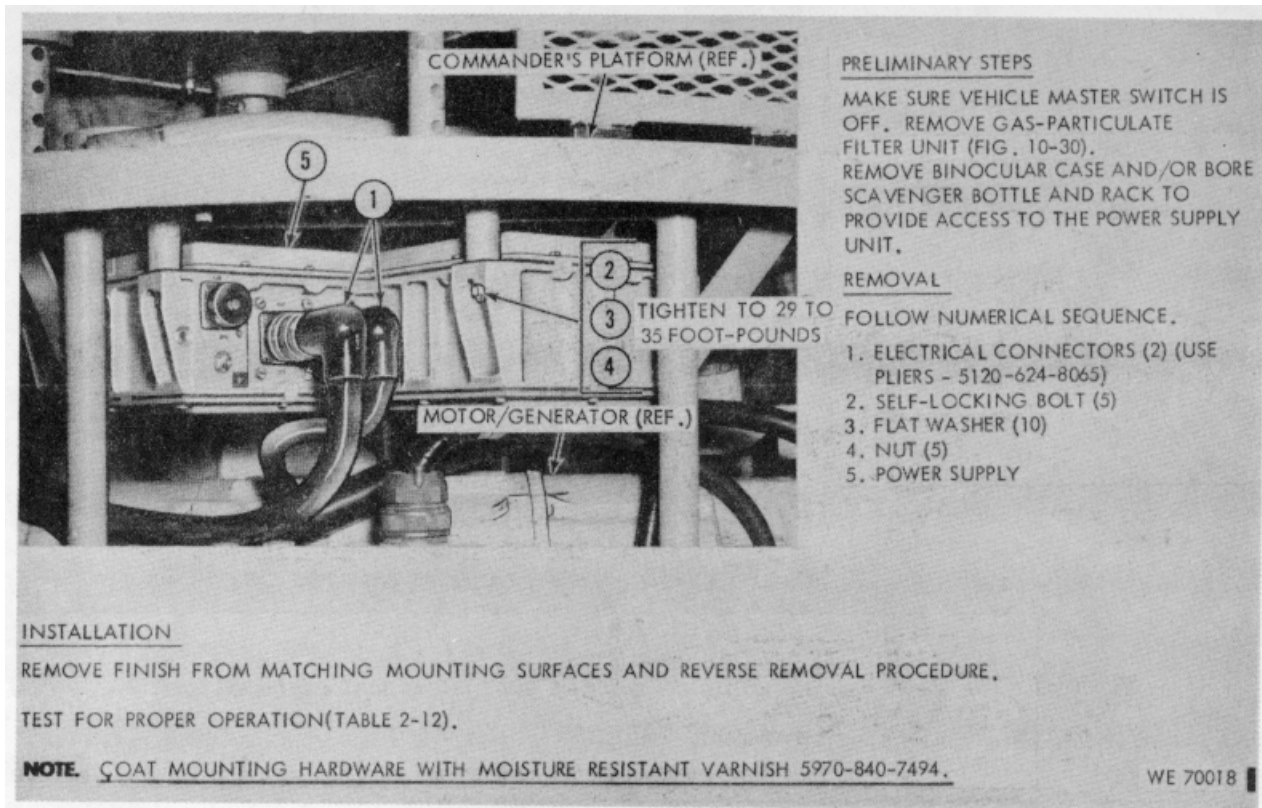

Figure 10-23. Removal/installation - missile subsystem power supply

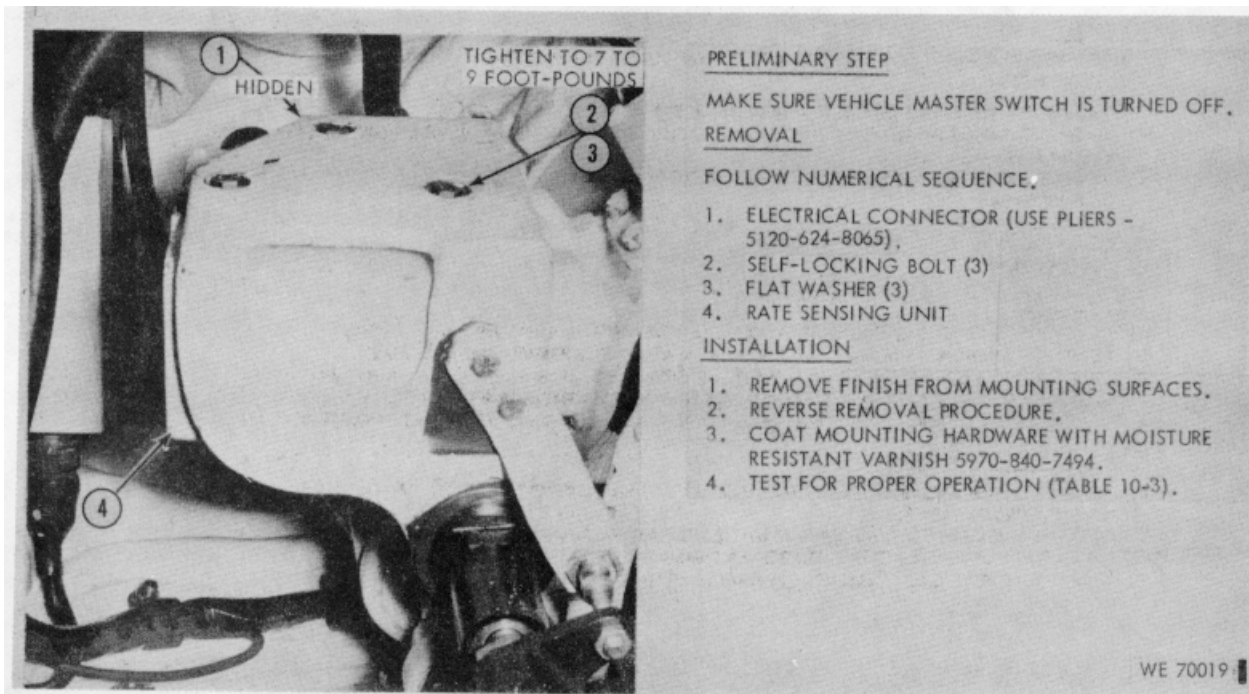

Figure 10-24. Removal/installation - rate sensing unit.

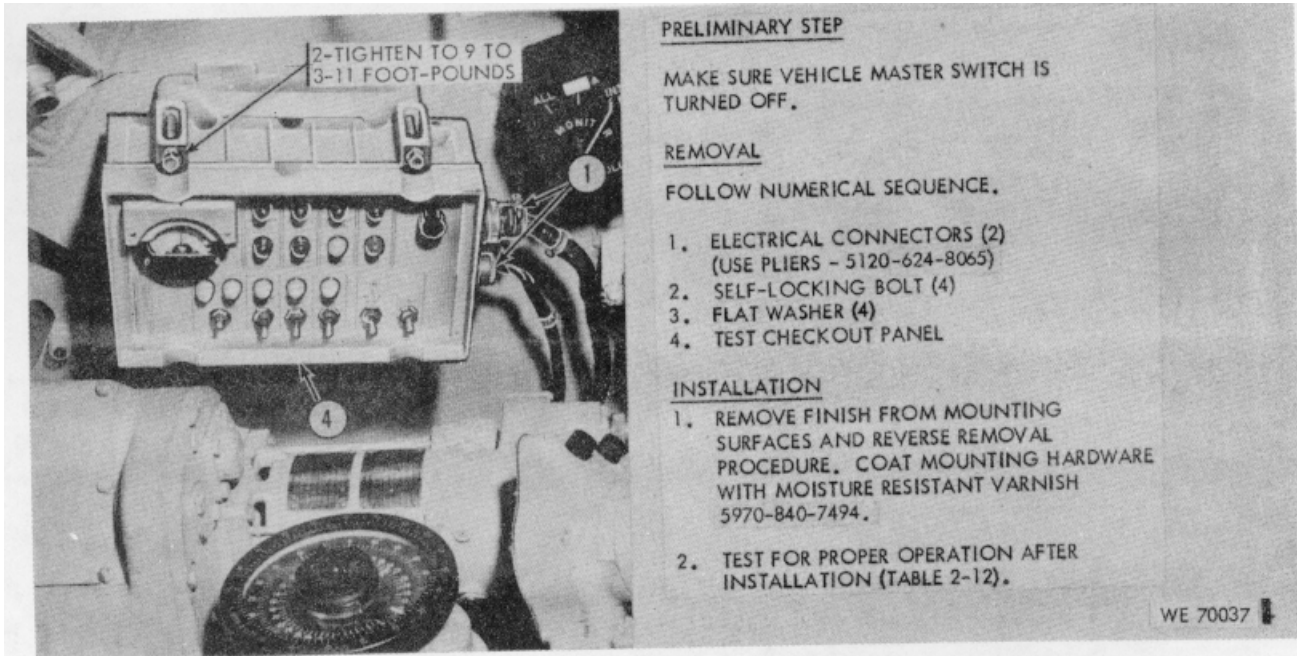

Figure 10-25. Removal/installation - missile subsystem test checkout panel

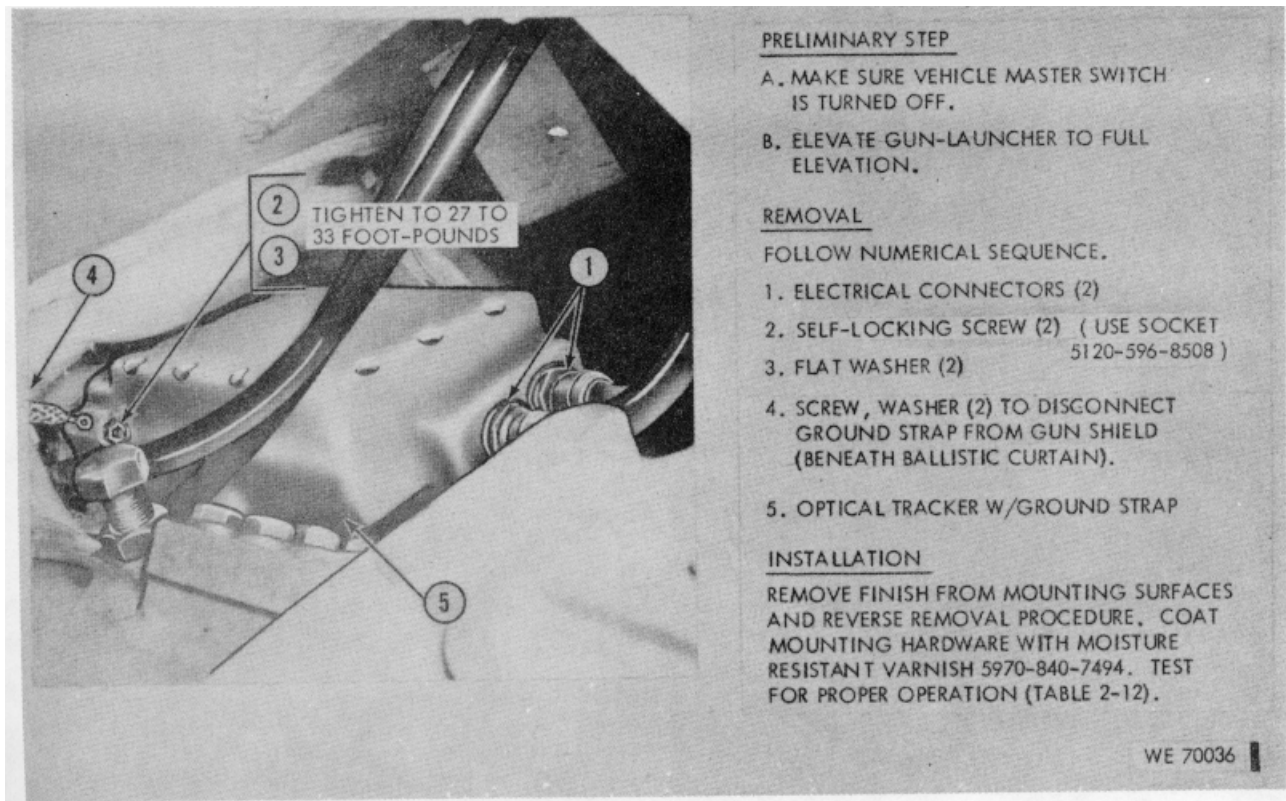

Figure 10-26. Removal/installation - optical tracker

**Section 10-5. ACCESSORY AND POWER SYSTEM**

**NOTE.** All references to M551A1 in this section pertain to vehicles equipped with laser range finder.

**10-8. General**

- a. This section contains Organizational maintenance instructions for the accessory and power system components listed in table 10-6 covering radio and intercom
- b. (Deleted)

c. Refer to figure 10-1 and table 10-1 for identification of electrical accessory and power system components.

d. Refer to TM 11-5820-401-20 for maintenance instructions equipment.

*Table 10-6. Turret Electrical Accessory and Power System Components*

Assembly or component	Figure reference	
	Remove/install	Repair
Circuit Cutout Box.....	10-27	19-27
Gas-Particulate Filter Unit .....	10-30	10-31
Dome Lights .....	9-95	9-96
Antennas (front or rear) .....	10-32	
Cupola Control Box .....	10-33	
Cupola Control Assembly .....	10-34	
Ventilating Fan (Co.-Ax Fume Control) .....	10-35	
Grenade Launcher Control Box.....	10-7	
Grenade Launcher Power Supply .....	10-35.1	
Cupola/Laser Control Box Assembly (M551A1 only) .....	10-35.2	
Remote Switch Assembly (M551A1 only) .....	10-35.3	
Resistor Box Assembly (17551A1 only) .....	10-35.4	

PRELIMINARY STEP

MAKE SURE VEHICLE MASTER SWITCH IS TURNED OFF.

REMOVAL

FOLLOW NUMERICAL SEQUENCE.

1. ELECTRICAL CONNECTORS (2)  
(USE PLIERS - 5120-00-624-8065).
2. SCREWS (2)
3. FLAT WASHERS (4)
4. NUTS (2)
5. CIRCUIT CUTOUT BOX

INSTALLATION

REMOVE FINISH FROM MOUNTING SURFACES ON CUTOUT BOX AND GUNNER'S SEAT. REVERSE REMOVAL SEQUENCE.

NOTE: AFTER INSTALLATION, TEST FOR PROPER OPERATION OF MISSILE SUBSYSTEM (TM 9-2350-230-10/2-1 FOR M551 OR TM 9-2350-230-10/2-3 FOR M551A1). COAT MOUNTING HARDWARE WITH INSULATING ENAMEL 8010-00-823-8046.

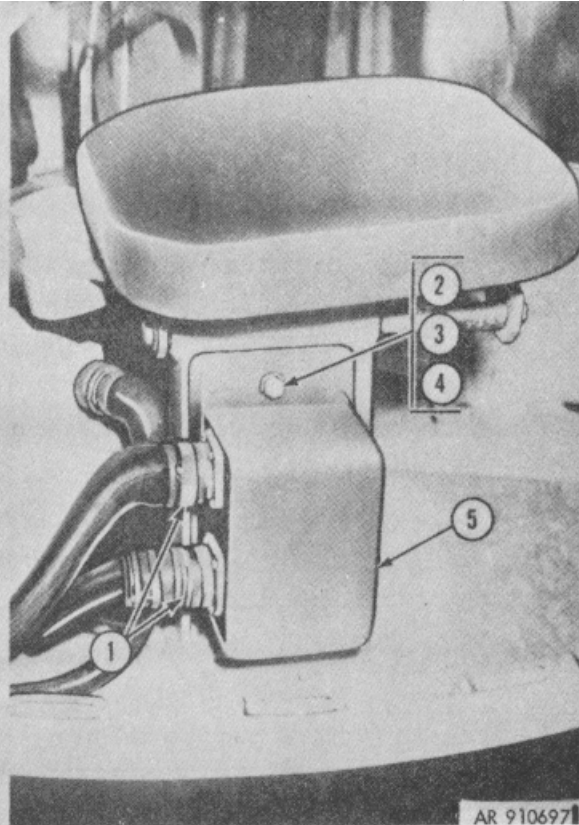
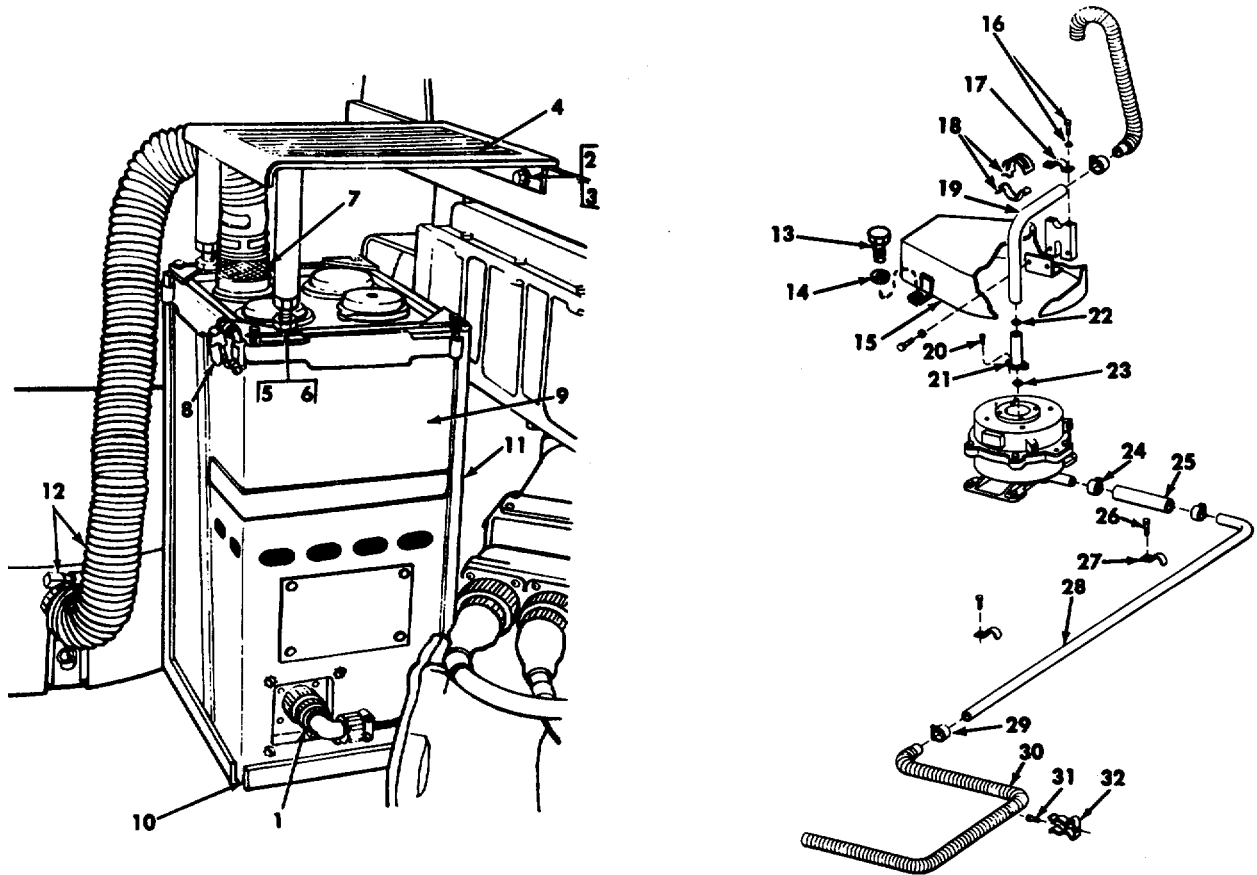

Figure 10-27. Removal/installation - circuit cutout box.

Pages 10-32.1 and 10-32.2 including figures 10-28 and 10-29 - deleted.



#### REMOVAL

FOLLOW NUMERICAL SEQUENCE.

- |                         |                             |               |
|-------------------------|-----------------------------|---------------|
| 1. ELECTRICAL CONNECTOR | 12. CLAMP AND HOSE          | 23. PACKING   |
| 2. SCREW (2)            | 13. SCREW (3)               | 24. CLAMP (2) |
| 3. WASHER (2)           | 14. WASHER (3)              | 25. HOSE      |
| 4. STEP PLATE           | 15. COVER                   | 26. SCREW (2) |
| 5. SCREW (2)            | 16. SCREW (2) AND WASHER(2) | 27. CLAMP (2) |
| 6. LOCK NUT (2)         | 17. CLAMP                   | 28. TUBE      |
| 7. HOSE COUPLING        | 18. CLIP AND BINDER         | 29. CLAMP     |
| 8. LATCH                | 19. TUBE                    | 30. HOSE      |
| 9. AIR PURIFIER         | 20. SCREW (2)               | 31. SCREW     |
| 10. SCREW (4) (HIDDEN)  | 21. BRACKET                 | 32. CLAMP     |
| 11. FRAME               | 22. PACKING                 |               |

#### INSTALLATION

REVERSE NUMERICAL SEQUENCE.

WE 11282

Figure 10-30. Removal/installation - air filter unit, air purifier, frame and step plate

(10-31 blank)/10-32



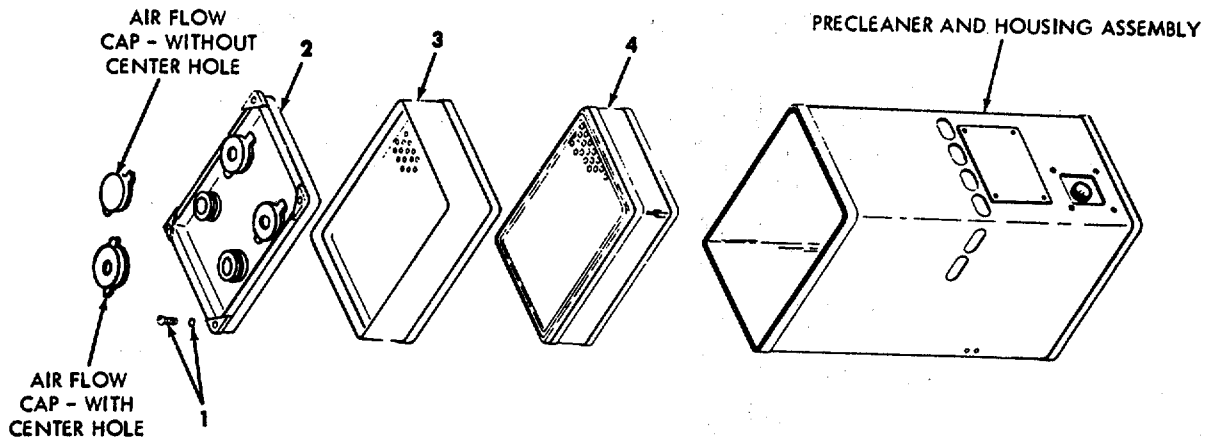

#### DISASSEMBLY

1. FOUR SCREWS AND LOCKWASHERS.
2. MANIFOLD ASSEMBLY.
3. M12A1 GAS FILTER.
4. M13 PARTICULATE FILTER.

**WARNING:** CONTAMINATED GAS AND PARTICULATE FILTERS MUST BE REMOVED AND DISPOSED OF ONLY BY ADEQUATELY TRAINED PERSONNEL (TM 3-304 AND TM 3-220).

#### CLEANING AND INSPECTION

**NOTE.** REFER TO TABLE 2-6 FOR TIME INTERVAL ON FILTER REPLACEMENT.

1. CLEAN MANIFOLD, HOUSING, GAS FILTER CONTAINER, AND PARTICULATE FILTER FRAME WITH CLEAN CLOTH AND DRY-CLEANING SOLVENT. DRY IMMEDIATELY.  
**CAUTION:** DO NOT PERMIT MOISTURE TO COME IN CONTACT WITH FILTER MATERIAL OF EITHER GAS OR PARTICULATE FILTER.
2. INSPECT HOUSING, GAS FILTER CONTAINER, PARTICULATE FILTER FRAME, AND MANIFOLD ASSEMBLY FOR DAMAGE OR WEAR.
3. REPLACE FILTERS IF DAMAGED, DIRTY, OR CONTAMINATED. REPLACE OR CEMENT GAS FILTER GASKET IF DAMAGED OR LOOSE.
4. REPLACE PRECLEANER AND HOUSING AS AN ASSEMBLY IF ANY DAMAGE OR MALFUNCTION IS DISCOVERED. REFER DAMAGED ASSEMBLY TO SUPPORTING MAINTENANCE FOR REPAIR.

#### ASSEMBLY

REVERSE DISASSEMBLY PROCEDURE. MAKE SURE FLUSH SIDE OF GAS FILTER IS ASSEMBLED AGAINST PARTICULATE FILTER (SEE ILLUSTRATION ABOVE).

WE 10971

Figure 10-31. Disassembly/cleaning/inspection/assembly - air filter unit

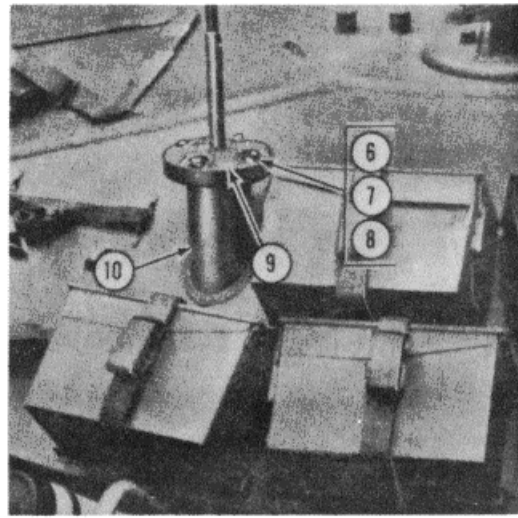
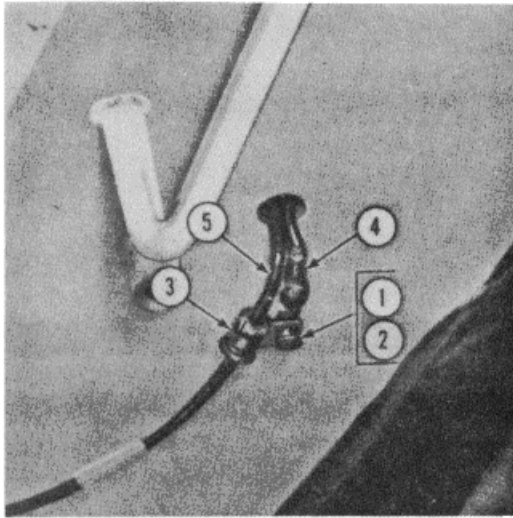

FRONT ANTENNA

REMOVAL

FOLLOW NUMERICAL SEQUENCE.

- 1. SCREW
- 2. LOCK WASHER
- 3. CLAMP
- 4. GROUND STRAP
- 5. CABLE ASSEMBLY (REFERENCE)

- 6. SCREW (4)
- 7. LOCK WASHER (4)
- 8. WASHER (4)
- 9. ANTENNA ASSEMBLY
- 10. CABLE CONNECTOR (HIDDEN)

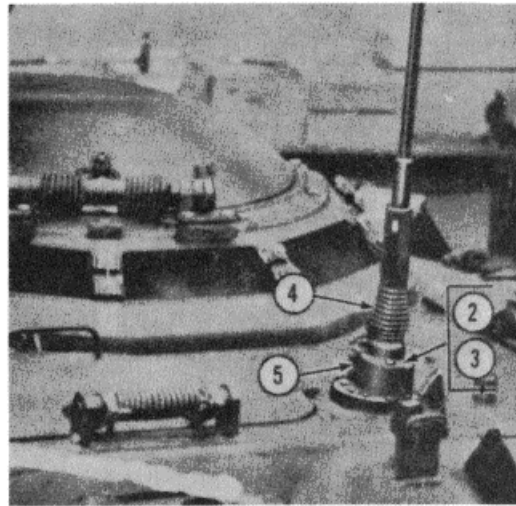
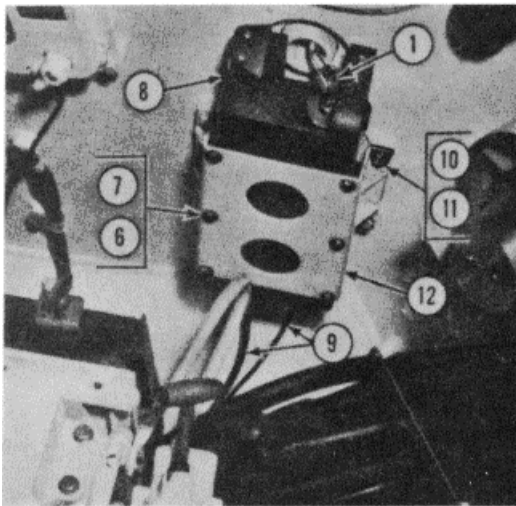

REAR ANTENNA

- 1. CABLE CONNECTOR
- 2. SCREW (4)
- 3. LOCK WASHER (4)
- 4. ANTENNA ASSEMBLY
- 5. SEAL (HIDDEN)
- 6. SCREW (6)

- 7. LOCK WASHER (6)
- 8. MATCHING UNIT
- 9. CABLE CONNECTOR (2) (HIDDEN)
- 10. SCREW (4)
- 11. WASHER (4)
- 12. BRACKET

Figure 10-32. Removal/installation - radio antenna - front or rear

**WARNING:** BEFORE LEAVING VEHICLE, MAKE CERTAIN THAT MASTER SWITCH AND LASER ON/OFF SWITCH ARE IN THE OFF POSITION. THIS IS TO PREVENT ACCIDENTAL AUTOMATIC ALIGNMENT OF CUPOLA TO MAIN WEAPON (M551A1 ONLY).

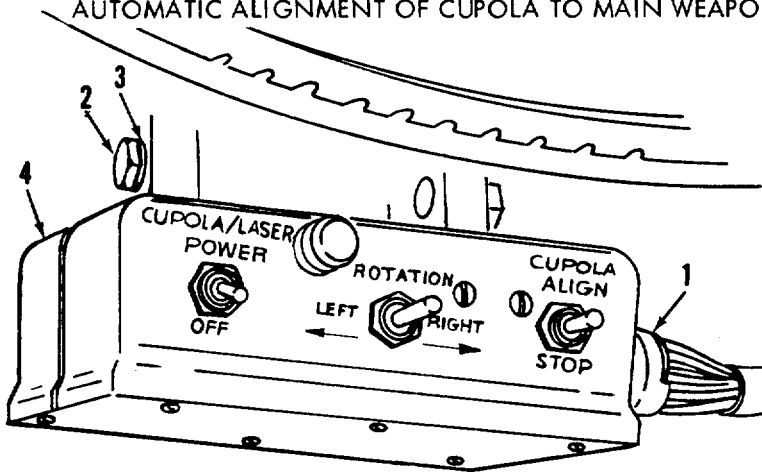

REMOVAL SEQUENCE

MAKE SURE VEHICLE MASTER SWITCH IS TURNED OFF.

1. ELECTRICAL CONNECTOR (USE PLIERS 5120-00-624-8065)
2. SCREW (2)
3. FLAT WASHER (2)
4. CUPOLA/LASER CONTROL BOX ASSEMBLY

INSTALLATION

REVERSE NUMERICAL SEQUENCE

AR 910698

Figure 10-33. Removal/installation - cupola/laser control box assembly (M551A1 only).

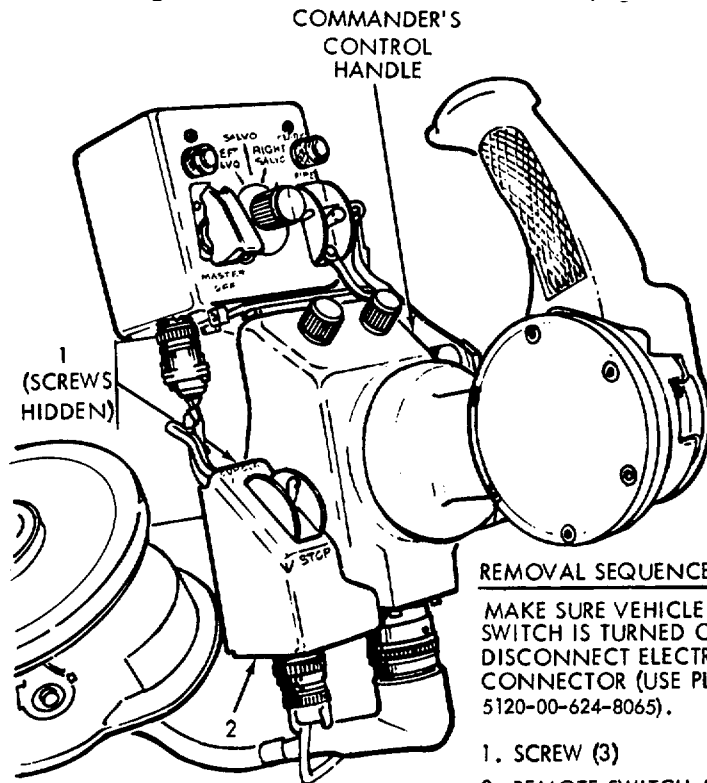

REMOVAL SEQUENCE

MAKE SURE VEHICLE MASTER SWITCH IS TURNED OFF. DISCONNECT ELECTRICAL CONNECTOR (USE PLIERS 5120-00-624-8065).

1. SCREW (3)
2. REMOTE SWITCH ASSEMBLY

NOTE: REINSTALL SCREWS TO COMMANDER'S CONTROL HANDLE

INSTALLATION

REVERSE NUMERICAL SEQUENCE

AR 900050

Figure 10-34. Removal/installation - remote switch assembly (M551A1 ONLY).

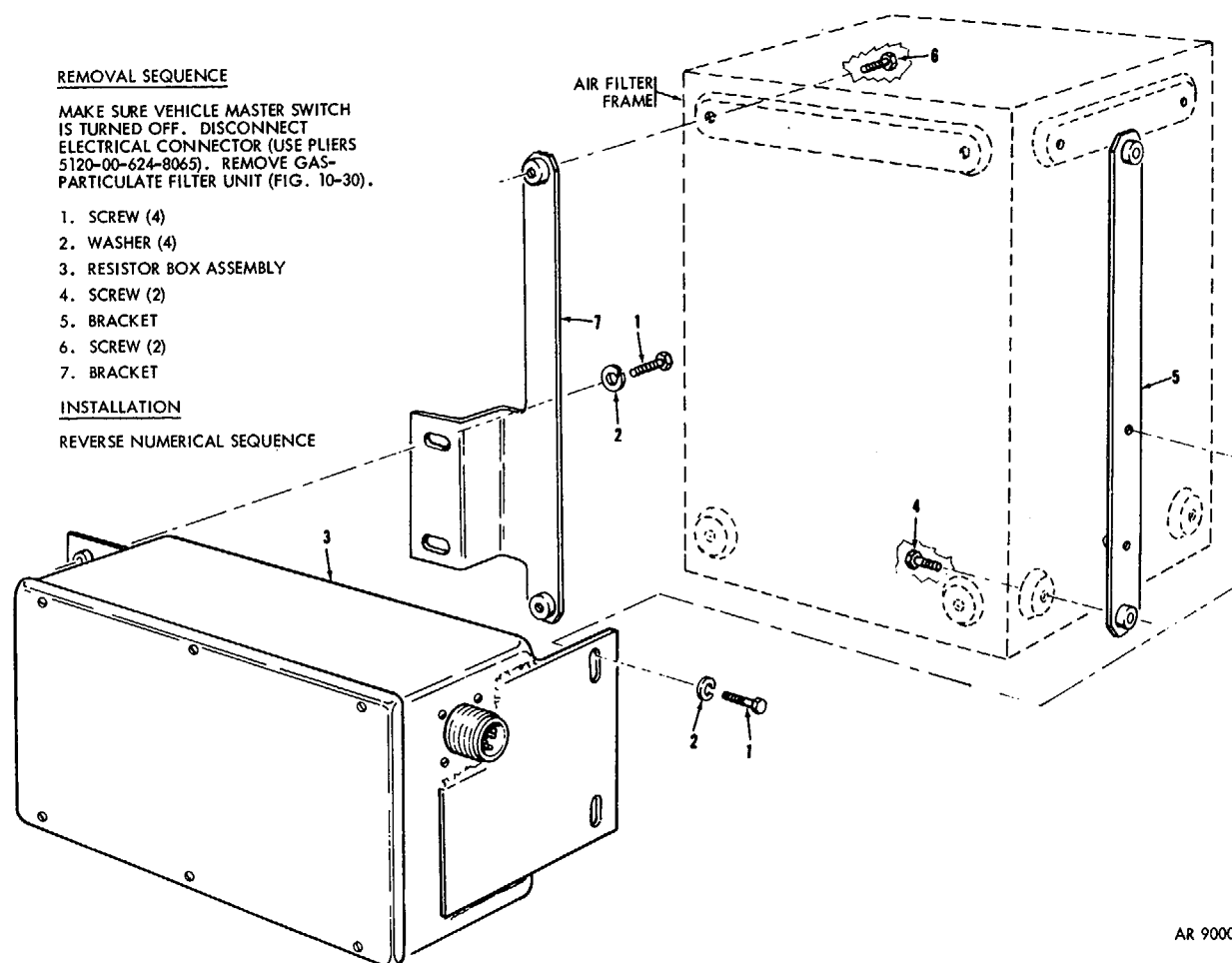

AR 900058

Figure 10-35. Removal/installation - resistor box assembly (M551A1 only).

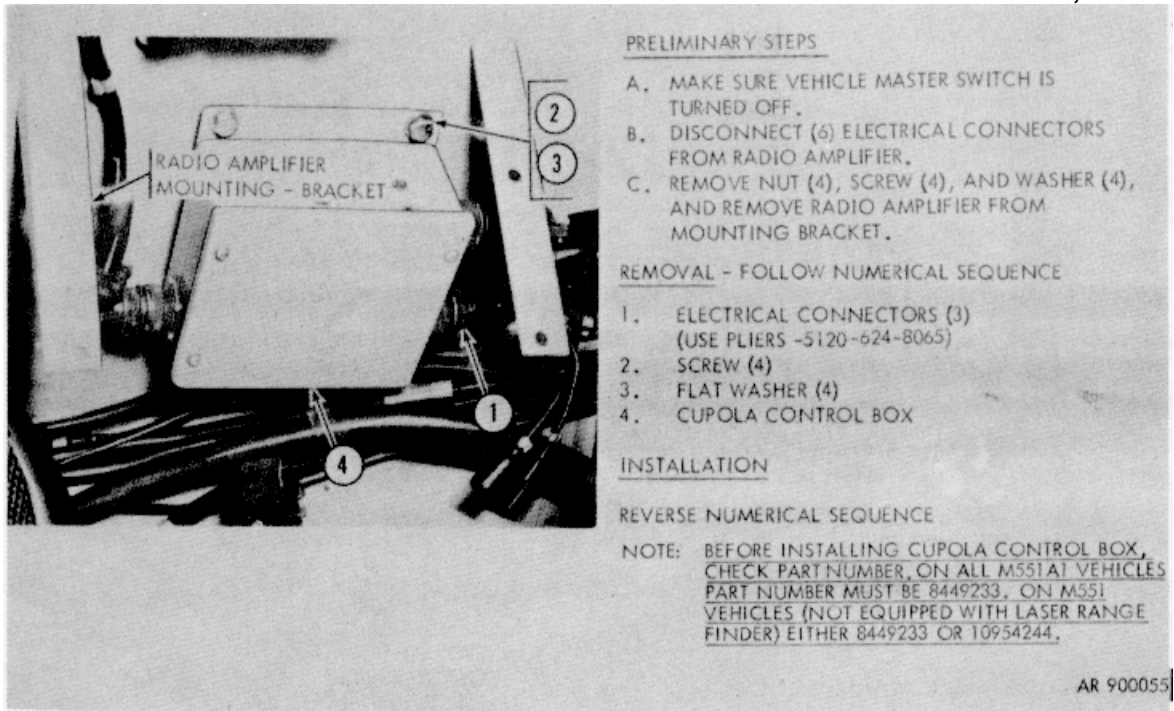

Figure 10-33. Removal/installation - cupola control box.

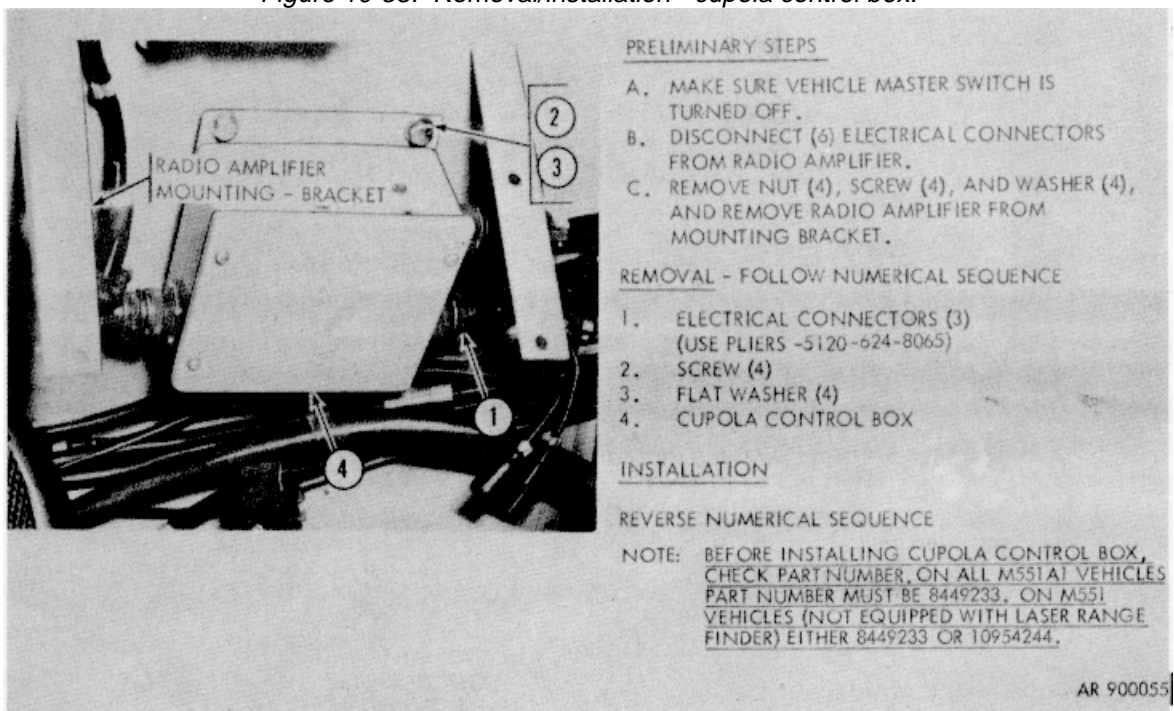

Figure 10-35.3. Removal/installation - cupola control assembly.

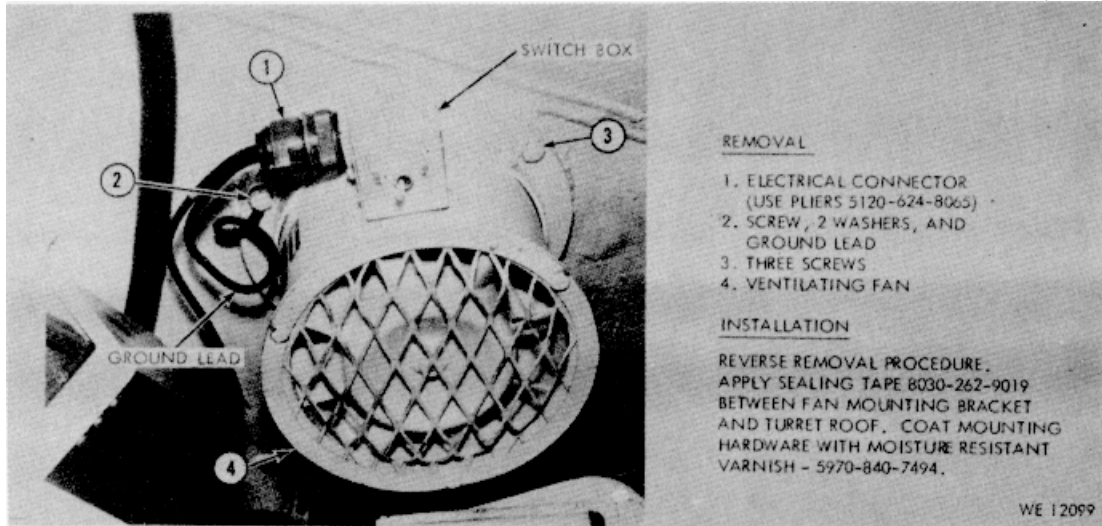

Figure 10-35. Removal/installation - turret ventilating fan.

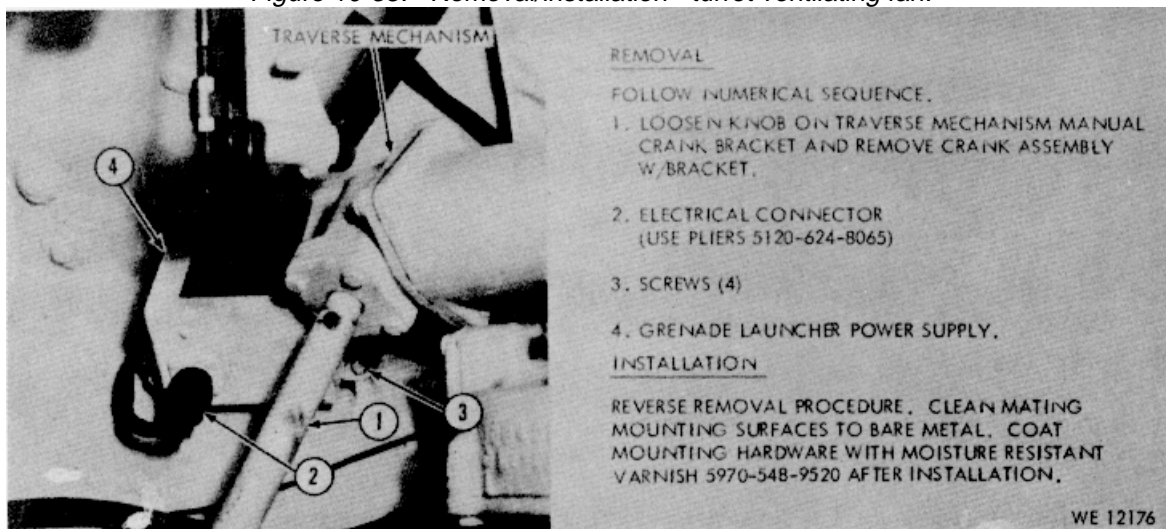

Figure 10-35.1. Removal/installation - grenade launcher power supply box.

**Section 10-6. TURRET COMPONENTS**

**NOTE. ALL references to M551AI in this section pertain to vehicles equipped with laser. range finder.**

**10-9. General**

a. This section contains organizational maintenance in-

structions for turret and cupola components listed in table 10-7.

*Table 10-7. Turret Components Figure reference*

Assembly or component	Figure reference	
	Remove/install	Repair
Traverse Lock.....	10-36	10-36
7.62-MM Machine Gun Ammunition Feed System .....	10-37	
Commander's Seat.....	10-38	10-39
Gunner's Seat.....	10-40	10-41
Loader's Seat and Back Rest.....	10-42	10-42
Turret Cable Guards.....	10-43	
Loader's Hatch Cover.....	10-44	10-44
Conventional Ammunition Horizontal Racks .....	10-45	10-45
Conventional Ammunition Vertical Racks .....	10-46	10-46
Turret Missile Rack and Portable Fire Extinguisher.....	10-47	
Gunner's Leg Guard.....	10-48	
Cupola Vision Blocks.....	10-49	
Telescope Protective Shield.....	10-49.1	
Cal .50 Machine Gun Mount Support Assembly .....	10-49.2	
Commander's Ballistic Shield Plate Assemblies .....	10-49.3, 10-49.4	
Turret Interior Stowage.....		10-50
Turret Exterior Stowage .....		10-52
Turret Floor Access Cover .....	4-3	
Cupola Seal for Transceiver (PM551AI only).....	10-53	
Loader's Periscope Stop (M551AI only) .....	10-54	
Index Pointers (M551A1 only) .....	10-55	
Laser Control Handle (M551AI only) .....	10-56	
Cable Covers (M551A1 only) .....	10-57	
Electronics Unit and Power Supply Covers (M551A1 only).....	10-58	
Commander's Ballistic Shields (M551A1 only).....	10-59	
<b>10-36.3</b>		

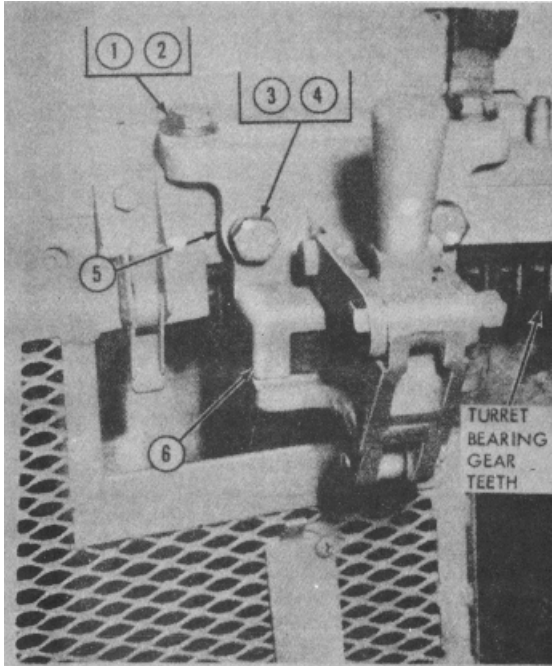

VIEW A

REMOVAL

FOLLOW NUMERICAL SEQUENCE.

- |               |                       |
|---------------|-----------------------|
| 1. SCREW (2)  | 4. WASHER (2)         |
| 2. WASHER (2) | 5. SHIM (AS REQUIRED) |
| 3. SCREW (2)  | 6. LOCK ASSEMBLY      |

INSTALLATION

1. SET LOCK ASSY IN PLACE IN UNLOCKED POSITION AND START TWO SCREWS (1) WITH WASHERS (2).
2. FORCE LOCK AGAINST TURRET RING AND TIGHTEN SCREWS (1) TO 160-180 POUNDS-FEET.
3. WITH FEELER GAGE DETERMINE SHIM (5) REQUIREMENTS. ADD 0.025 IN. SHIM TO THIS MEASUREMENT.
4. INSTALL TWO SCREWS (3), WASHERS (4), AND SHIMS (STEP 3). TIGHTEN SCREWS TO 160-180 POUNDS-FEET.
5. ENGAGE LOCK AND CHECK FOR BACKLASH BY MANUALLY MOVING TURRET.
6. REFER TO VIEW B. ADJUST FOR MINIMUM BACKLASH BY REMOVING PINS (3) AND (4) AND ROTATING CLEVIS (18) CCW TO DECREASE CLEARANCE, AND CW TO INCREASE CLEARANCE.
7. INSTALL LEVER ASSEMBLY (5), PINS (3) AND (4), AND TWO COTTER PINS (1).

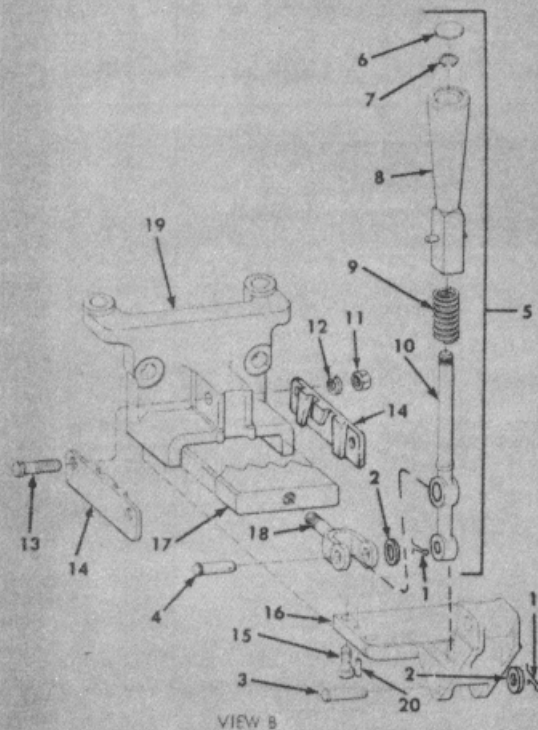

VIEW B

DISASSEMBLY

FOLLOW NUMERICAL SEQUENCE, REPLACING UNSERVICEABLE PARTS AS REQUIRED.

LEGEND

- |                   |                     |
|-------------------|---------------------|
| 1. COTTER PIN (2) | 11. NUT (2)         |
| 2. WASHER (2)     | 12. LOCK WASHER (2) |
| 3. PIN            | 13. SCREW (2)       |
| 4. PIN            | 14. PLATE (2)       |
| 5. LEVER ASSEMBLY | 15. SCREW (4)       |
| 6. PLUG           | 16. BRACKET         |
| 7. RETAINING RING | 17. RACK GEAR       |
| 8. HANDLE GRIP    | 18. CLEVIS          |
| 9. SPRING         | 19. BRACKET         |
| 10. LEVER         | 20. PIN             |

ASSEMBLY

REVERSE NUMERICAL SEQUENCE.

ADJUST CLEVIS (18) SO THAT MOVEMENT OF GEAR RACK (17) IS 5/8 INCH FROM OPEN TO LOCK POSITION. LUBRICATE MOVING PARTS WITH PL-5.

WE 66647

Figure 10-36. Removal/disassembly/assembly/ installation - turret traverse lock.



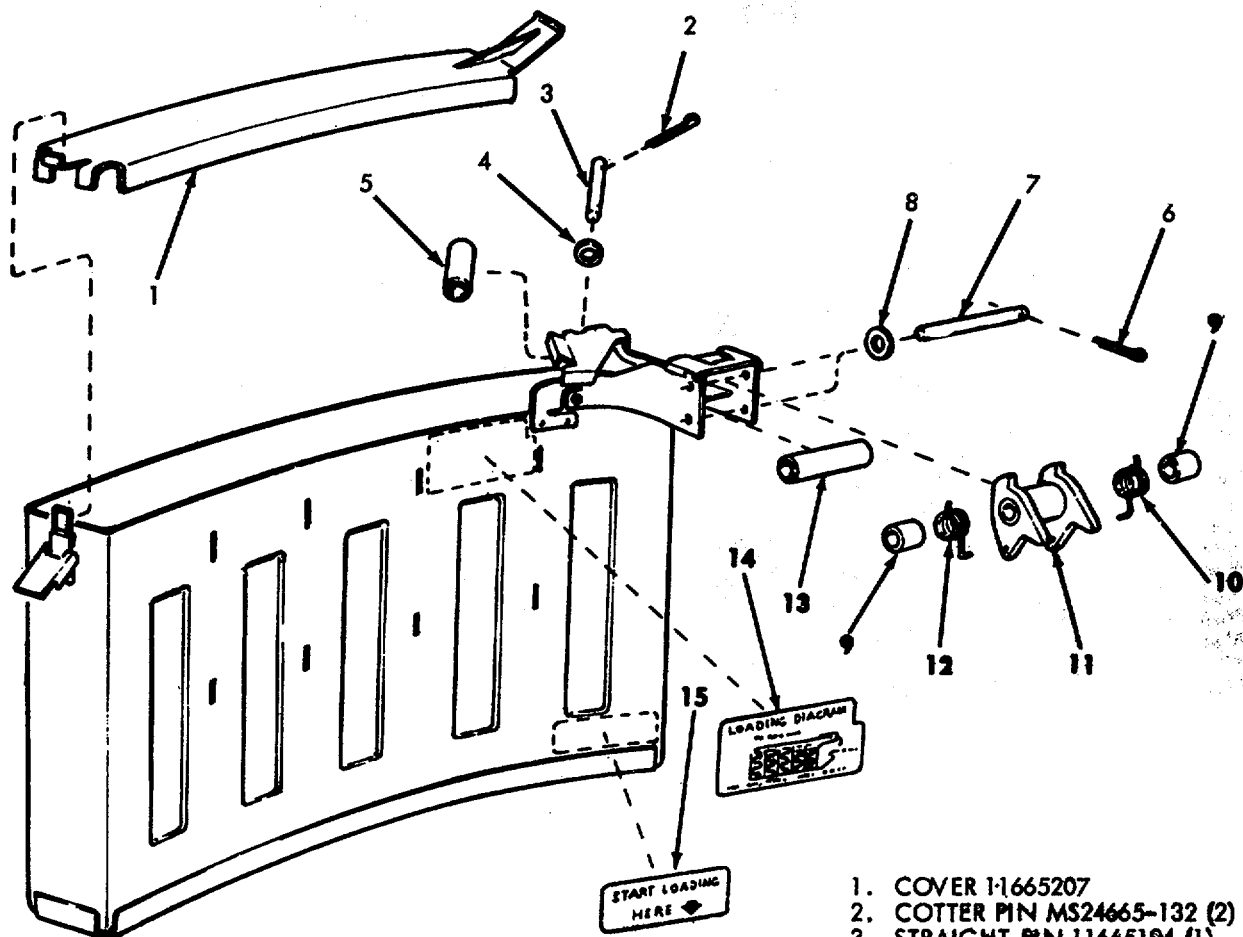

1. COVER 11665207
2. COTTER PIN MS24665-132 (2)
3. STRAIGHT PIN 11665194 (1)
4. FLAT WASHER MS27183-11 (2)
5. ROLLER 11664757-5 (1)
6. COTTER PIN MS24665-132 (4)
7. STRAIGHT PIN 10948987 (2)
8. FLAT WASHER MS27183-11 (4)
9. SLEEVE SPACER 11664749 (2)
10. HELICAL SPRING 11652935-1 (1)
11. PAWL ASSEMBLY 8338921
12. HELICAL SPRING 11652935-2 (1)
13. ROLLER 11664757-1
14. INSTRUCTION PLATE 11665195
15. INSTRUCTION PLATE 11664747

#### REMOVAL/DISASSEMBLY

REMOVE COVER AND REMOVE SIX HEXAGON CAP SCREWS FROM THREE MOUNTING BRACKETS, AND REMOVE AMMUNITION BOX. THEN FOLLOW NUMERICAL SEQUENCE.

#### ASSEMBLY/INSTALLATION

REVERSE ABOVE PROCEDURE. TIGHTEN SCREWS TO 20-25 FT-LB.

#### INSTALLATION NOTE

BEND TANGS ON SPRINGS TO LOCK IN PLACE ON PAWL  
LUBRICATE PAWL ASSEMBLY WITH PL AT ASSEMBLY

WE 70864 |

Figure 10-37. Removal/installation - 7. 62-mm machine gun ammunition feed system.

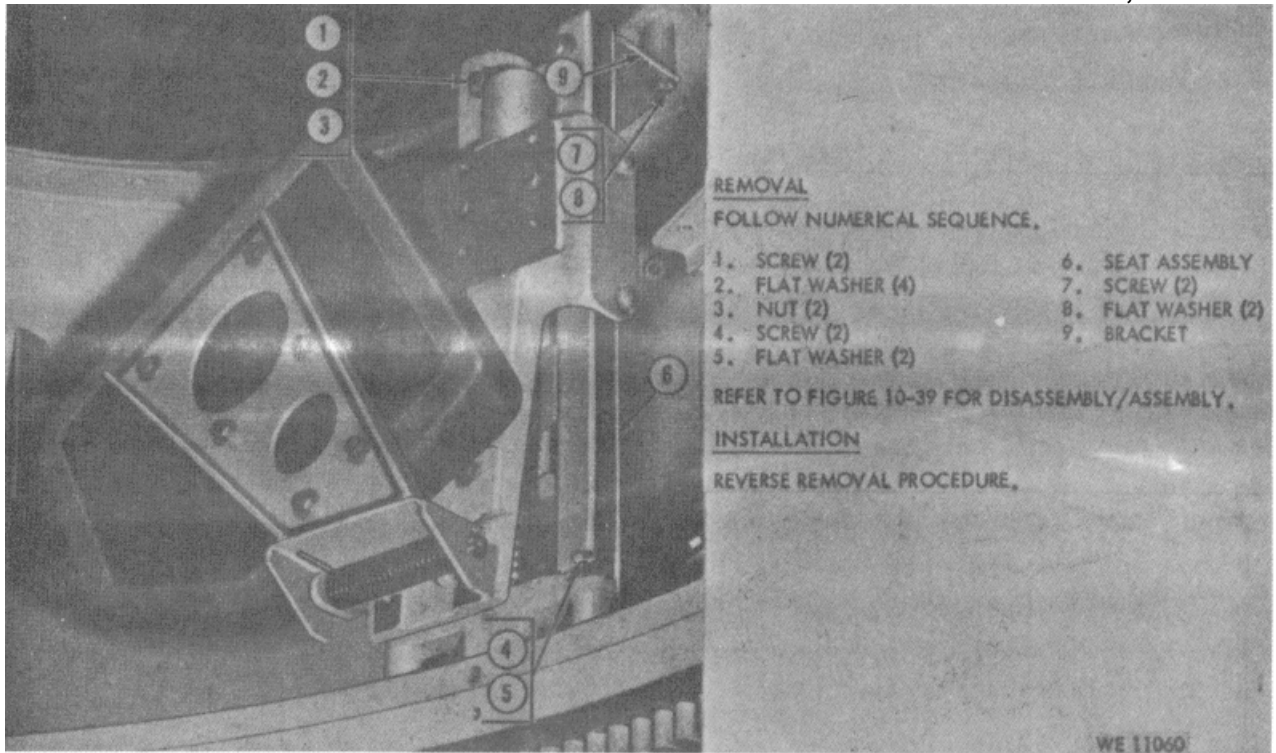
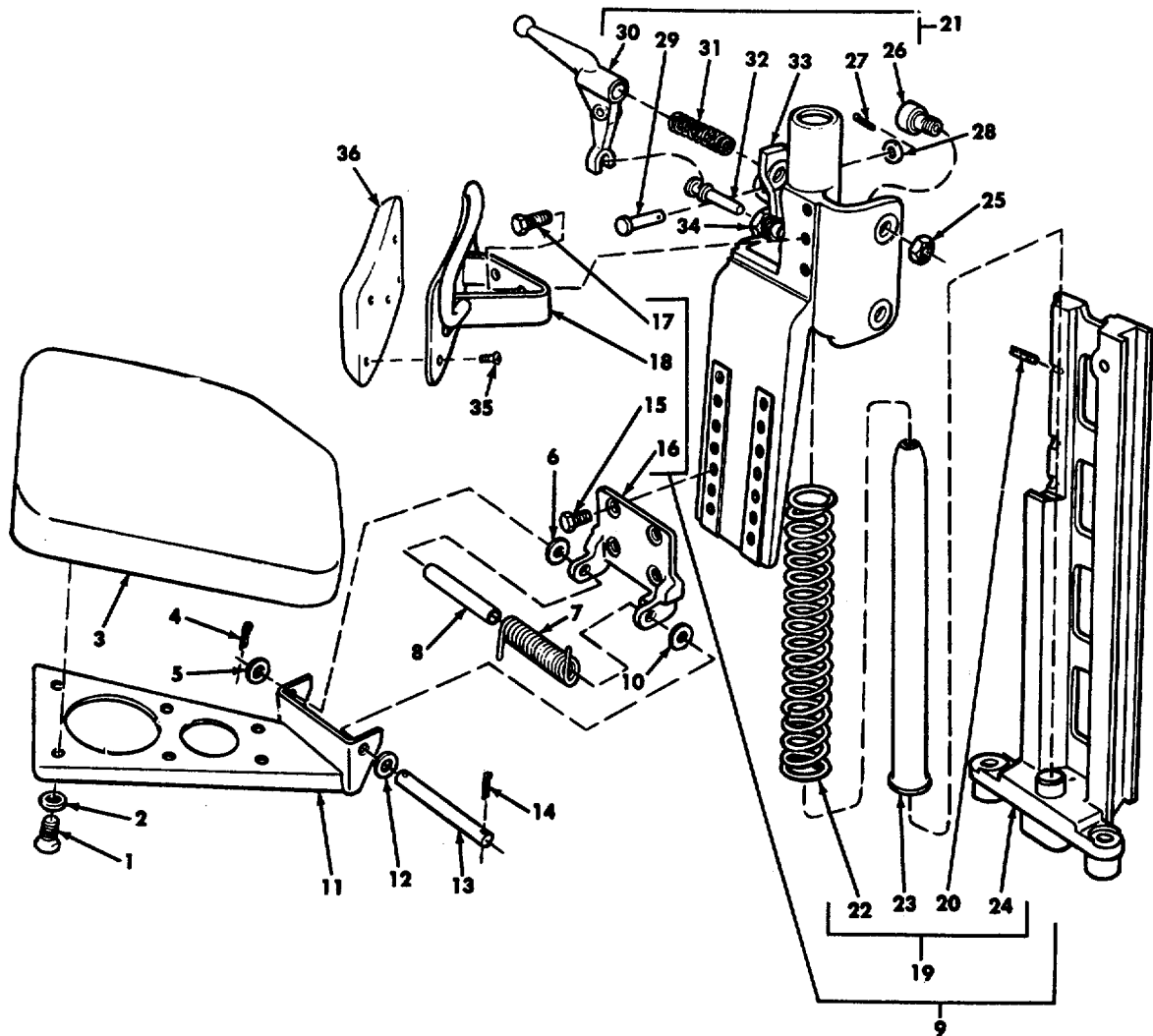

Figure 10-38. Removal/installation - commander's seat assembly

**DISASSEMBLY**

FOLLOW NUMERICAL SEQUENCE.

NOTES. 1. USE CAUTION IN REMOVING TORSION SPRING (ITEM 7). SPRING IS UNDER TORSIONAL LOAD.  
 2. USE CAUTION IN REMOVING BRACKET GROUP (ITEM 21). SPRING (ITEM 22) IS UNDER COMPRESSION.

- |                    |                             |                      |                       |
|--------------------|-----------------------------|----------------------|-----------------------|
| 1. SCREW (6)       | 12. FLAT WASHER             | 23. GUIDE            | 35. SCREW (5)         |
| 2. FLAT WASHER (6) | 13. PIN                     | 24. SUPPORT          | 36. CUSHION           |
| 3. SEAT CUSHION    | 14. COTTER PIN              | 25. NUT (4)          |                       |
| 4. COTTER PIN      | 15. SCREW (4)               | 26. CAM FOLLOWER (4) | ITEMS 35 AND 36 ON    |
| 5. FLAT WASHER     | 16. BRACKET                 | 27. COTTER PIN       | LATER VEHICLES ONLY.  |
| 6. FLAT WASHER     | 17. SCREW (2)               | 28. FLAT WASHER      | EARLIER VEHICLES HAVE |
| 7. TORSION SPRING  | 18. BACK REST               | 29. HEADED PIN       | ONE-PIECE BACKREST.   |
| 8. TUBE            | 19. BRACKET - SUPPORT GROUP | 30. RELEASE LEVER    |                       |
| 9. SUPPORT GROUP   | 20. SPRING PIN              | 31. SPRING           |                       |
| 10. FLAT WASHER    | 21. BRACKET GROUP           | 32. LOCK PIN         |                       |
| 11. SEAT SUPPORT   | 22. SPRING                  | 33. BRACKET          |                       |
|                    |                             | 34. SLEEVE           |                       |

**ASSEMBLY**

REVERSE DISASSEMBLY PROCEDURE.

WE 11061A ■

Figure 10-39. (Superseded) Disassembly/assembly - commander's seat assembly

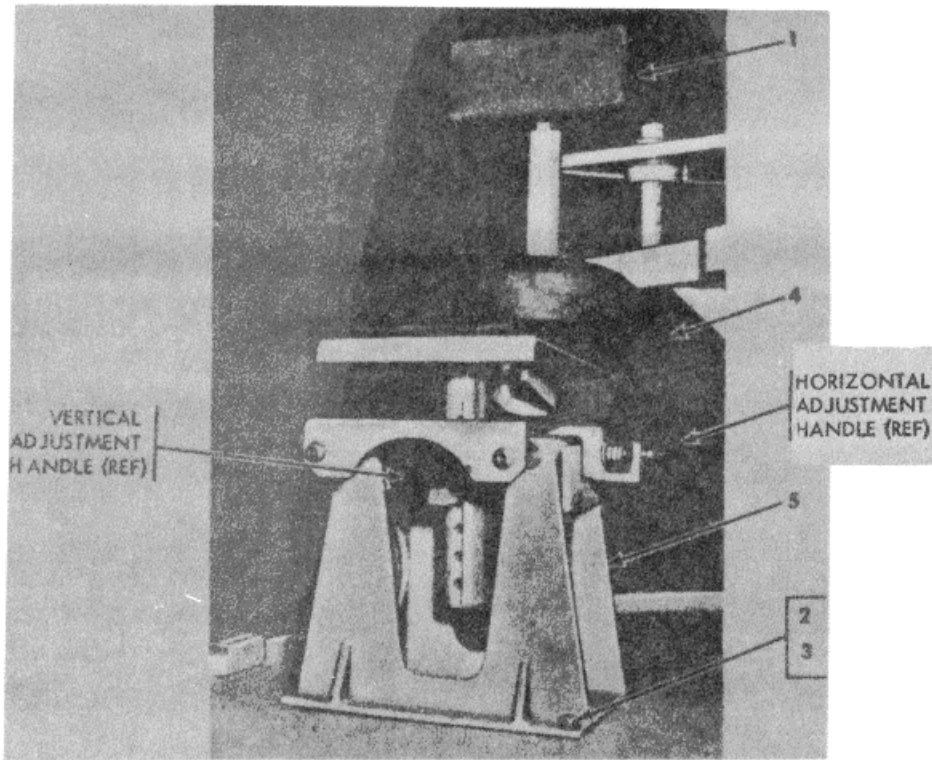

PRELIMINARY STEP

REMOVE CIRCUIT CUTOUT BOX ASSEMBLY FROM SEAT SUPPORT (FIG. 10-27).

REMOVAL

FOLLOW NUMERICAL SEQUENCE.

**NOTE.** PULL OUT ON VERTICAL ADJUSTMENT HANDLE AND LIFT SEAT TO REMOVE SEAT FROM SUPPORT ASSEMBLY.

1. BACK REST
2. SCREW (4)
3. FLAT WASHER (4)
4. SEAT CUSHION ASSEMBLY
5. SEAT SUPPORT ASSEMBLY

INSTALLATION

REVERSE REMOVAL PROCEDURE.

WE 11051 A

Figure 10-40. (Superseded) Removal/installation - gunner's seat assembly

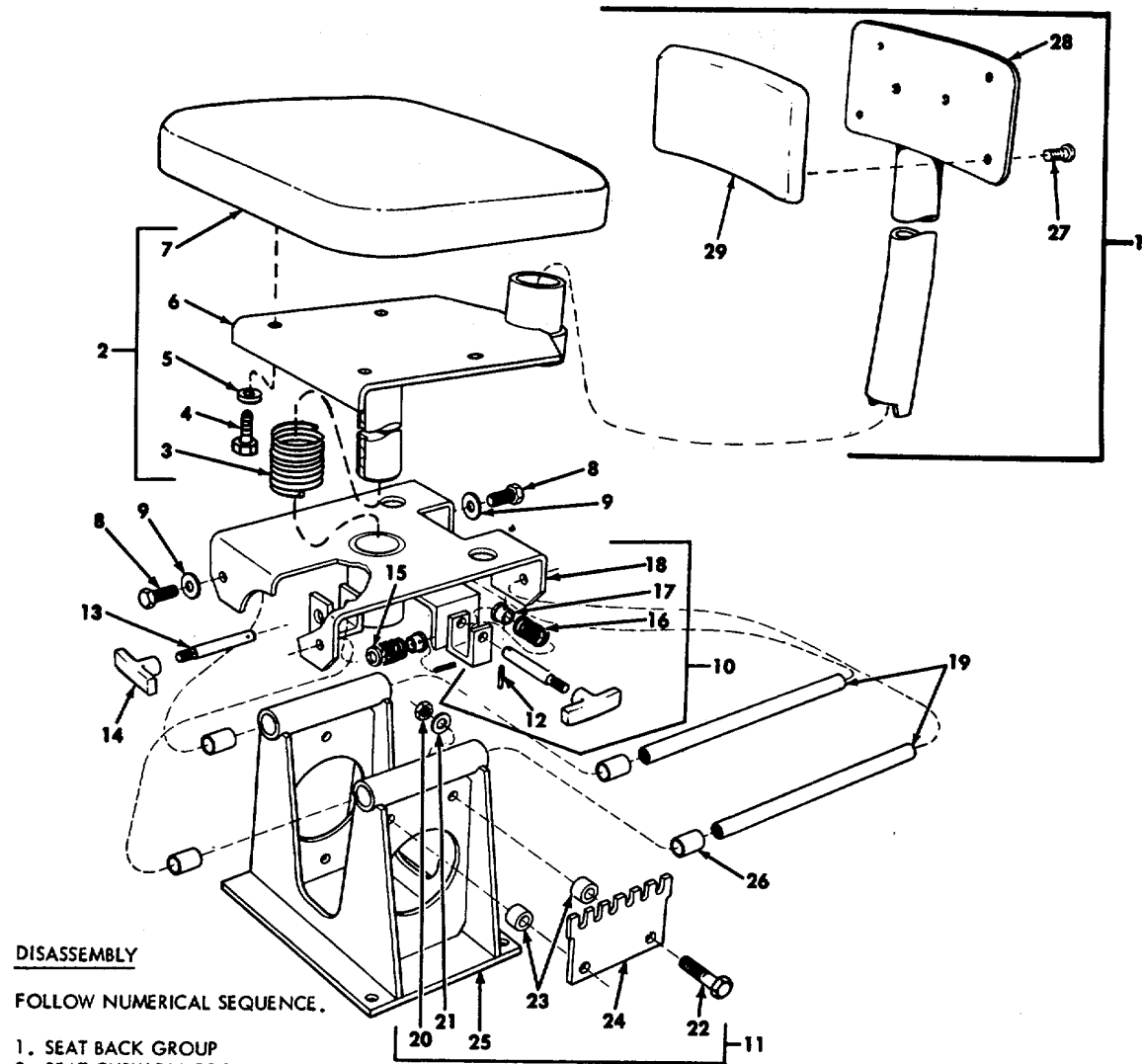

**DISASSEMBLY**

FOLLOW NUMERICAL SEQUENCE.

- 1. SEAT BACK GROUP
- 2. SEAT CUSHION GROUP
- 3. SPRING
- 4. SCREW (4)
- 5. FLAT WASHER (4)
- 6. PLATFORM
- 7. CUSHION
- 8. SCREW (4)
- 9. FLAT WASHER (4)
- 10. BRACKET GROUP
- 11. SUPPORT GROUP
- 12. SPRING PIN (2)
- 13. PIN (2)

**ASSEMBLY**

REVERSE DISASSEMBLY PROCEDURE.

- 14. HANDLE (2)
- 15. WASHER - SEE NOTE.
- 16. SPRING (2)

- 17. COLLAR (2)
- 18. BRACKET
- 19. TUBE (2)
- 20. NUT (2)
- 21. FLAT WASHER (2)
- 22. SCREW (2)
- 23. SPACER (2)
- 24. ADJUSTMENT PLATE
- 25. SUPPORT
- 26. BEARING (4)
- 27. SCREW (6)
- 28. SEAT BACK
- 29. CUSHION

NOTE. TO PREVENT SEAT ROTATION WHILE ADJUSTING HEIGHT, USE WASHER (15) AS REQUIRED TO PREVENT PIN (13) FROM CLEARING VERTICAL SLOT WHEN HANDLE IS PULLED. (PIN MUST CLEAR HOLE IN POST WHEN HANDLE IS PULLED.)

WE 11052A

Figure 10-41. (Superseded) Disassembly/assembly - gunner's seat assembly

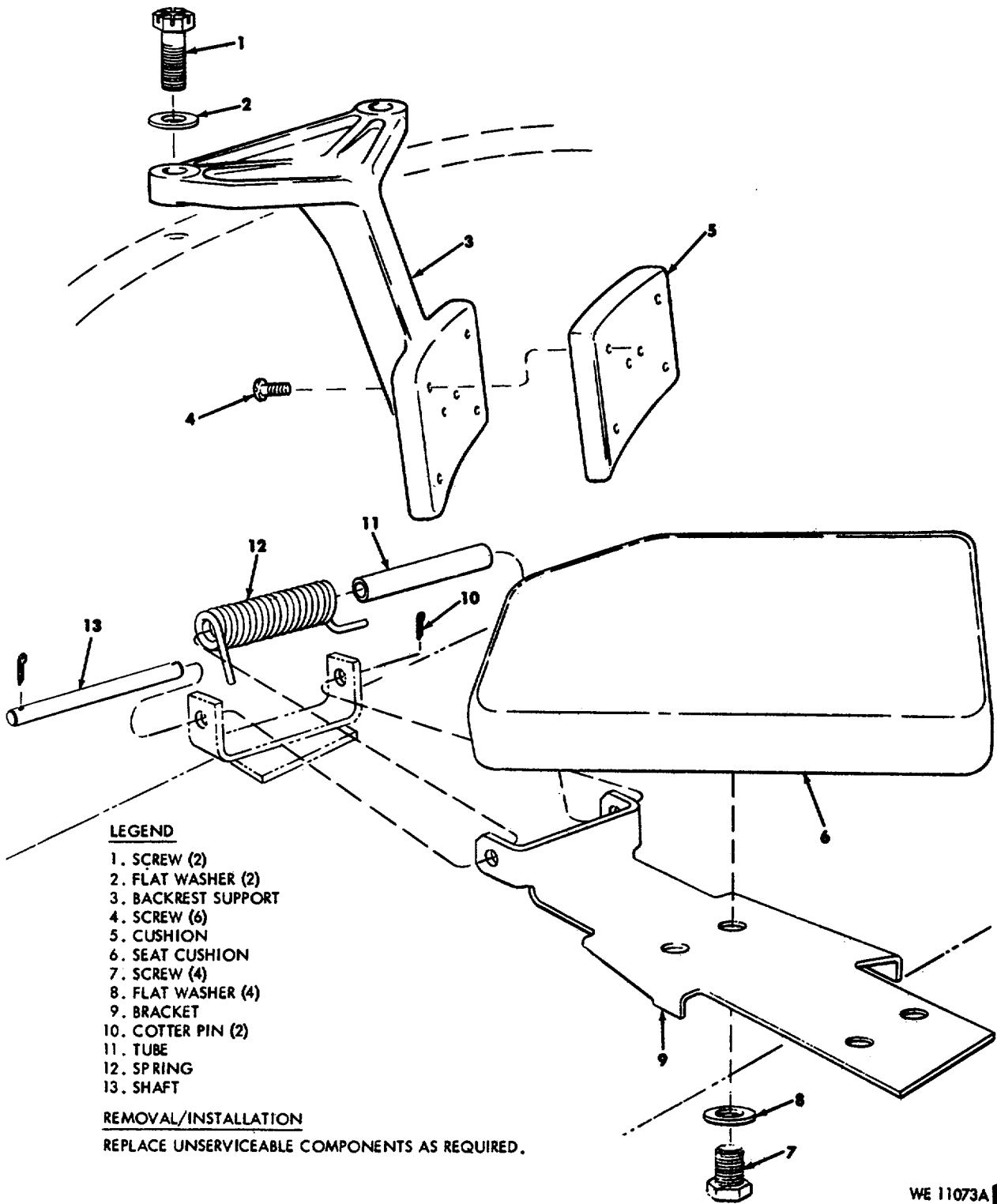

Figure 10-42. (Superseded) Removal/installation - loader's seat and backrest

Pages 10-42. 1 and 10-42. 2, including figures 10-42. 1 and 10-42. 2 - deleted.

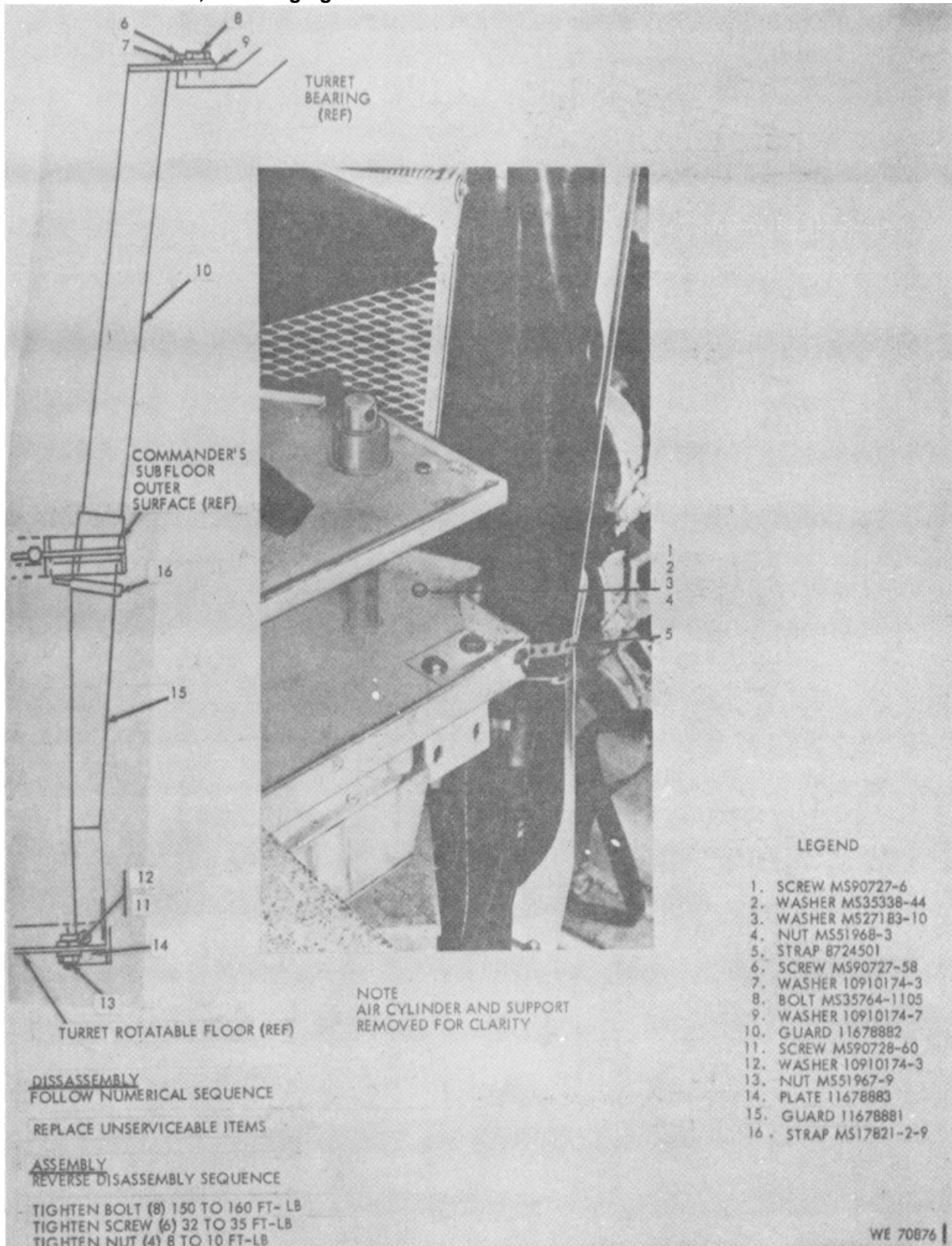

Figure 10-43. Removal/installation - turret cable guards.

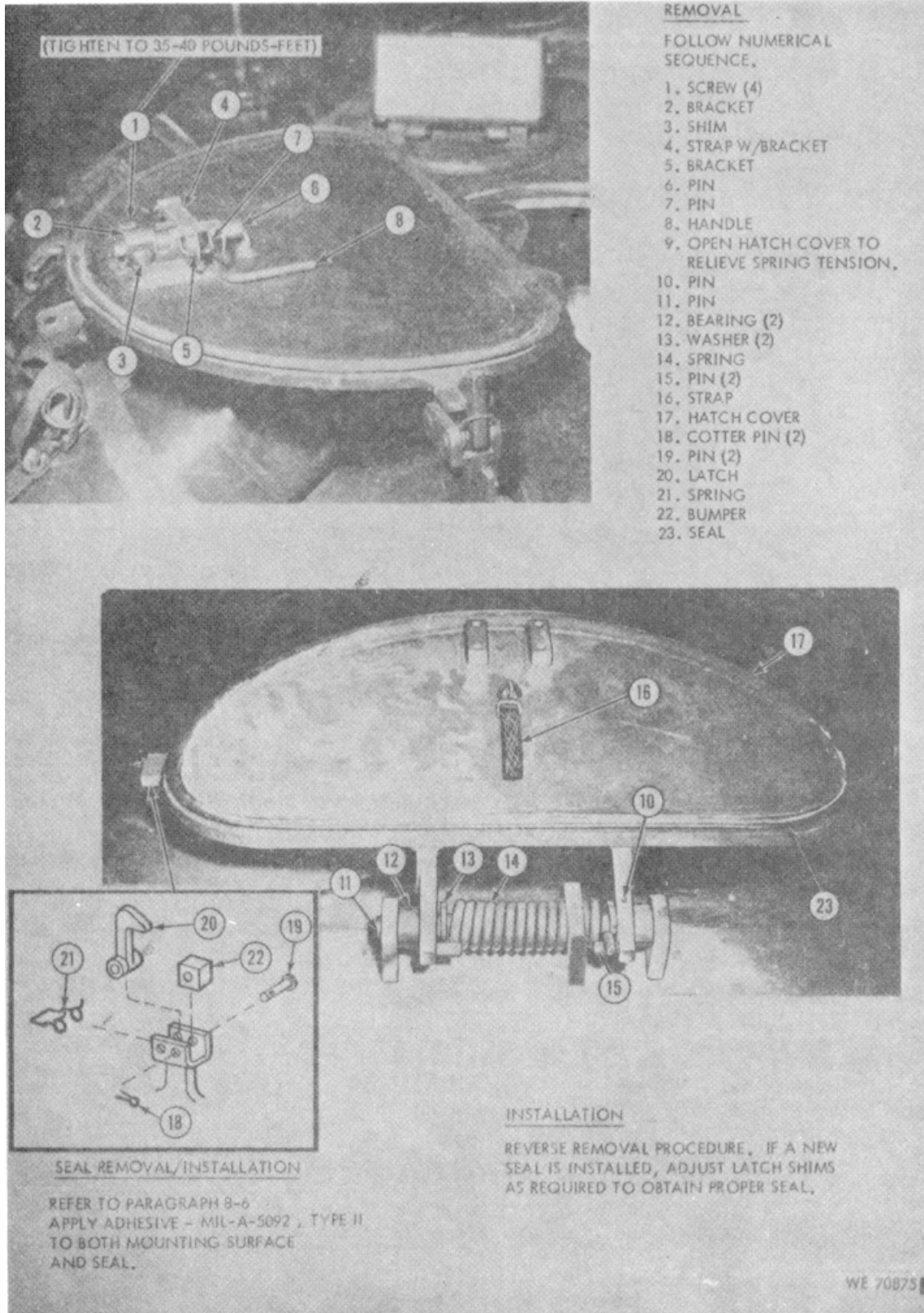
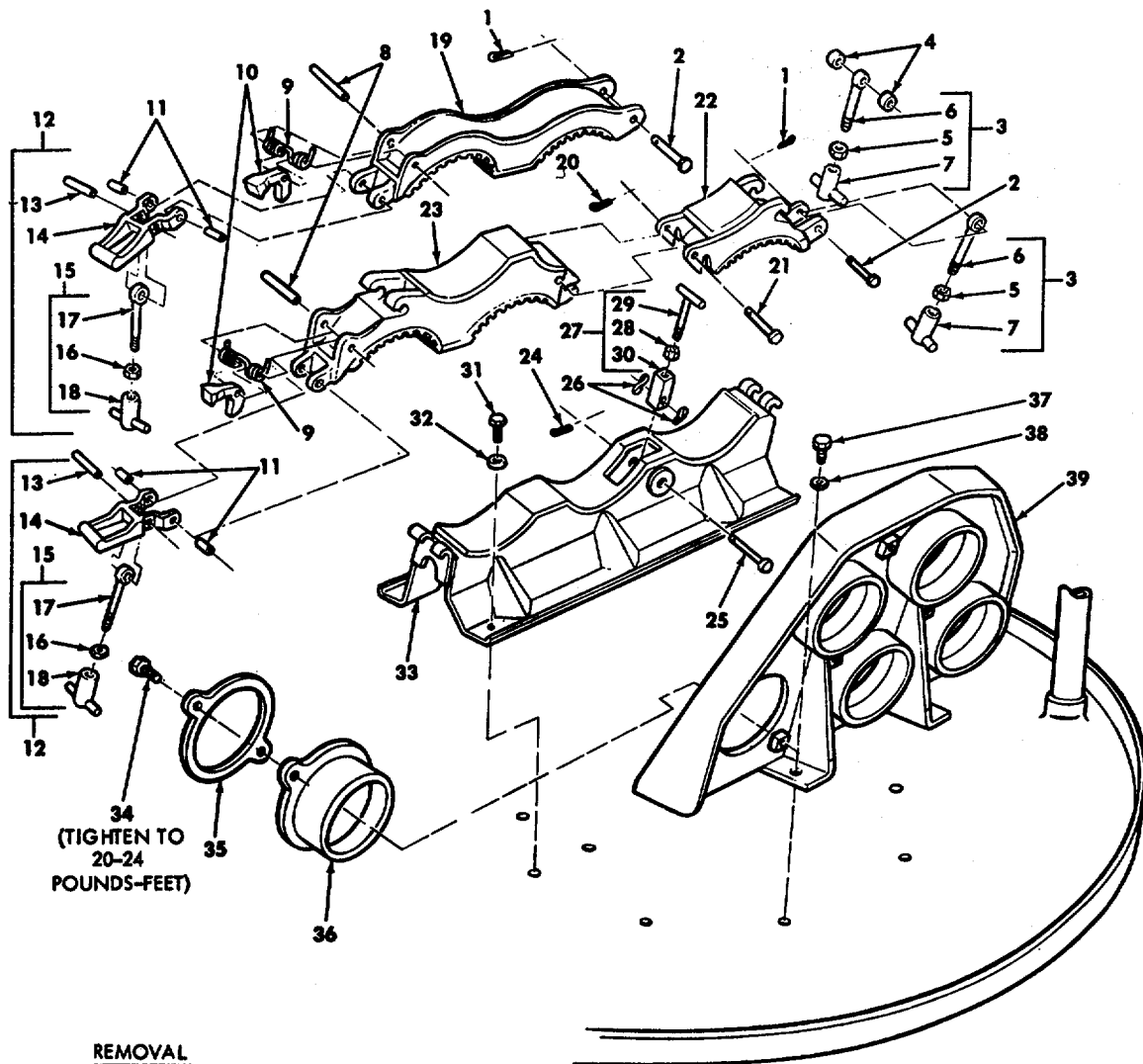

Figure 10-44. Removal/installation - loader's hatch cover and components



**REMOVAL**

FOLLOW NUMERICAL SEQUENCE.

- |                    |                             |                       |                     |
|--------------------|-----------------------------|-----------------------|---------------------|
| 1. COTTER PIN (2)  | 11. SPRING PIN (4)          | 21. HEADED PIN        | 31. SCREW (4)       |
| 2. HEADED PIN (2)  | 12. RELEASE LEVER GROUP (2) | 22. ARM               | 32. FLAT WASHER (4) |
| 3. CATCH GROUP (2) | 13. SPRING PIN (2)          | 23. ARM               | 33. CRADLE          |
| 4. SPACER (2)      | 14. LEVER (2)               | 24. COTTER PIN        | 34. SCREW (10)      |
| 5. NUT (2)         | 15. CATCH GROUP (2)         | 25. HEADED PIN        | 35. RETAINER (5)    |
| 6. BOLT (2)        | 16. NUT (2)                 | 26. SPRING WASHER (2) | 36. SUPPORT (5)     |
| 7. CATCH (2)       | 17. BOLT (2)                | 27. CATCH GROUP       | 37. SCREW (4)       |
| 8. SPRING PIN (2)  | 18. CATCH (2)               | 28. NUT               | 38. FLAT WASHER (4) |
| 9. SPRING (2)      | 19. ARM                     | 29. CATCH             | 39. SUPPORT         |
| 10. PAWL (2)       | 20. COTTER PIN              | 30. SOCKET            |                     |

REPLACE UNSERVICEABLE COMPONENTS.

**INSTALLATION**

REVERSE REMOVAL PROCEDURE.

WE 11050

Figure 10-45. Removal/installation/repair - turret conventional ammunition horizontal racks.

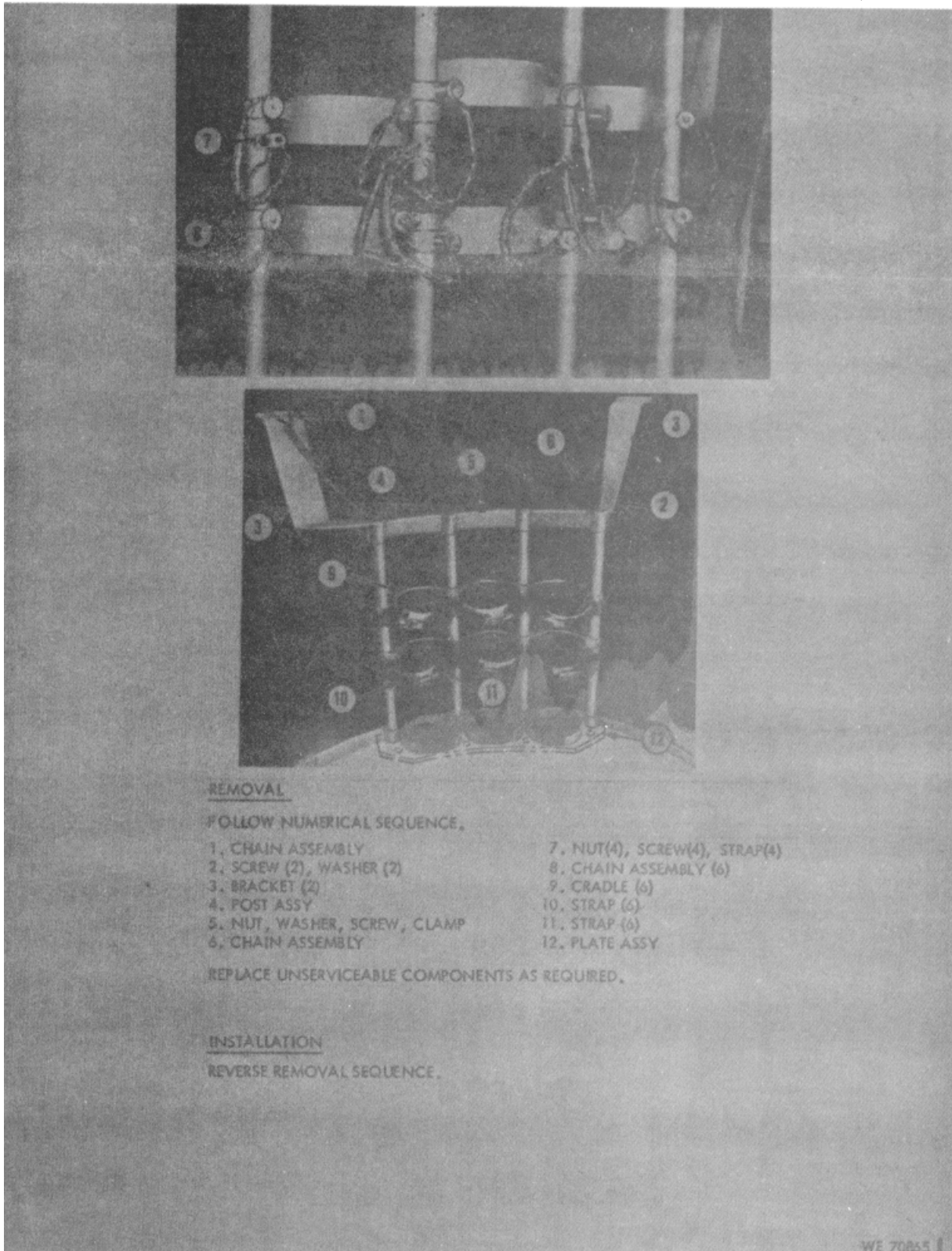
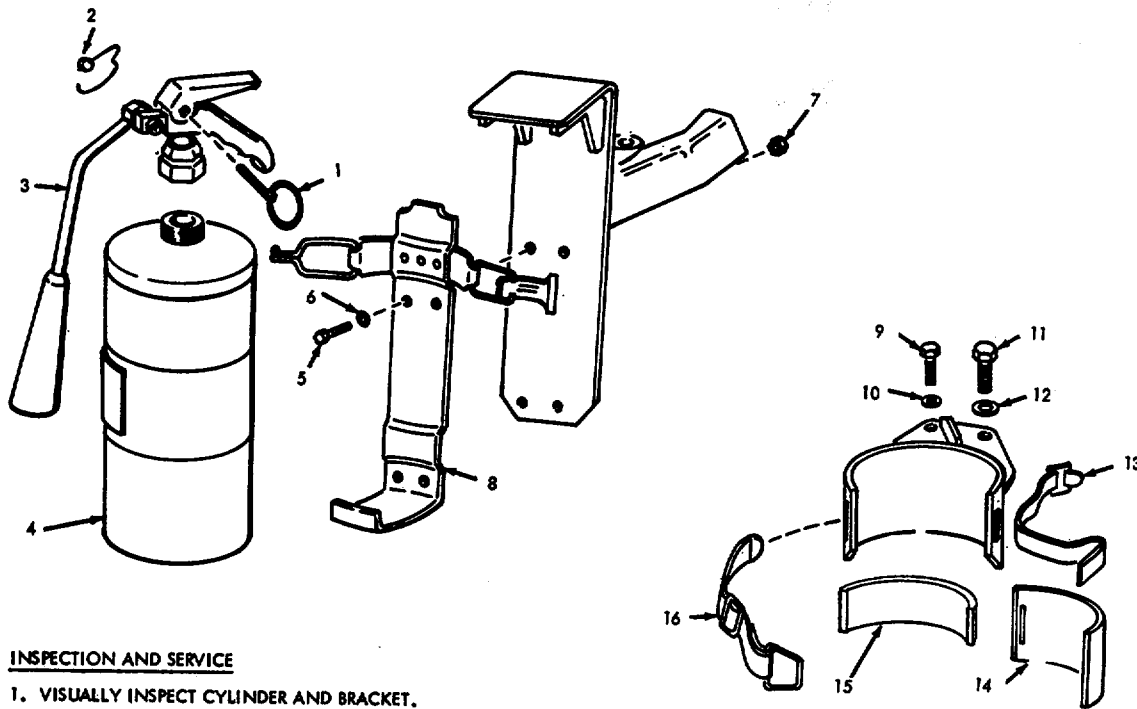

Figure 10-46. Removal/installation/repair - turret conventional ammunition vertical racks.



**INSPECTION AND SERVICE**

1. VISUALLY INSPECT CYLINDER AND BRACKET.
2. REPLACE CYLINDER IF SEAL IS BROKEN OR MISSING FROM CONTROL ASSEMBLY.
3. MAKE SURE CYLINDER IS PROPERLY INSTALLED IN BRACKET, AND THAT RING PIN LOCKS TRIGGER. WHEN INSTALLING NEW CYLINDER, REMOVE INSTRUCTION PLATE AND SLIDE ON NEW CYLINDER.

REPLACE UNSERVICEABLE ITEMS.  
TO ATTACH RUBBER PADS APPLY ADHESIVE - MIL-A-5092, TYPE II

- |                     |                       |
|---------------------|-----------------------|
| 1. RING             | 12. WASHER            |
| 2. SEAL WIRE        | 13. STRAP             |
| 3. CONTROL ASSEMBLY | 14. STRAP             |
| 4. CYLINDER         | 15. PAD               |
| 5. SCREW (4)        | 16. STRAP             |
| 6. WASHER (4)       | 17. SUPPORT           |
| 7. NUT (4)          | 18. PAD               |
| 8. BRACKET          | 19. STRAP CLAMP ASSY. |
| 9. SCREW            | 20. STRAP             |
| 10. WASHER          | 21. SCREW (2)         |
| 11. BOLT            | 22. WASHER (3)        |
|                     | 23. STRAP (2)         |

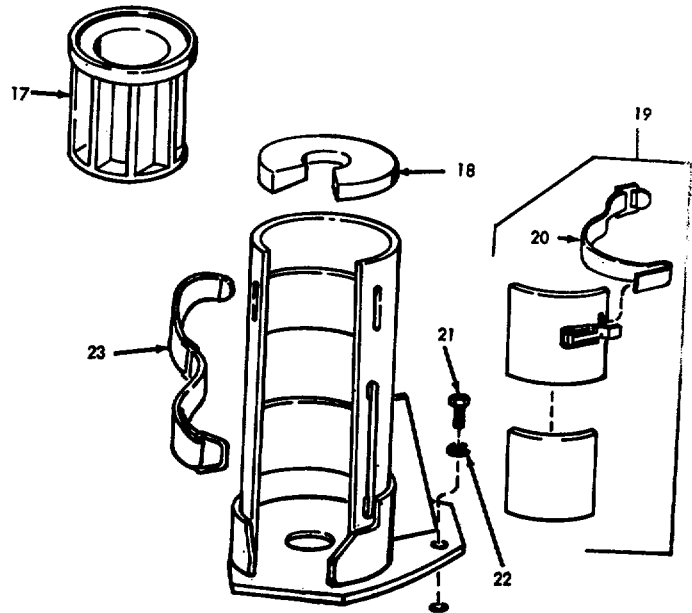

WE 70860

Figures 10-47.1 and 10-47.2 - deleted.

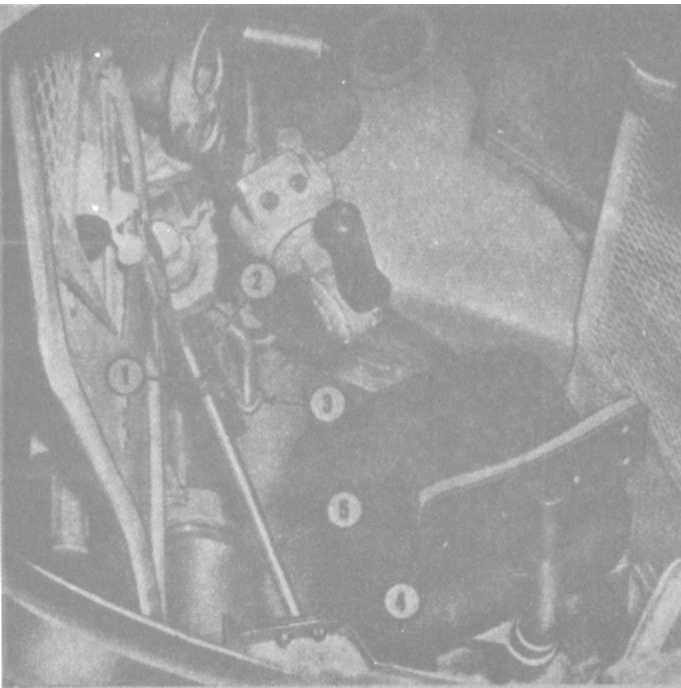

PRELIMINARY STEP

REMOVE HARNESS FROM GUARD.

REMOVAL

REMOVE PAD AND GUARD BY FOLLOWING NUMERICAL SEQUENCE.

1. SCREW (2), FLAT WASHER (4), NUT (2)
2. PAD
3. SCREW (2), FLAT WASHER (2)
4. SCREW (2), FLAT WASHER (4), NUT (2)
5. GUARD

INSTALLATION

REVERSE REMOVAL PROCEDURE.

WE 11062

*Figure 10-48. Removal/installation - gunner's leg guard and protective pad*

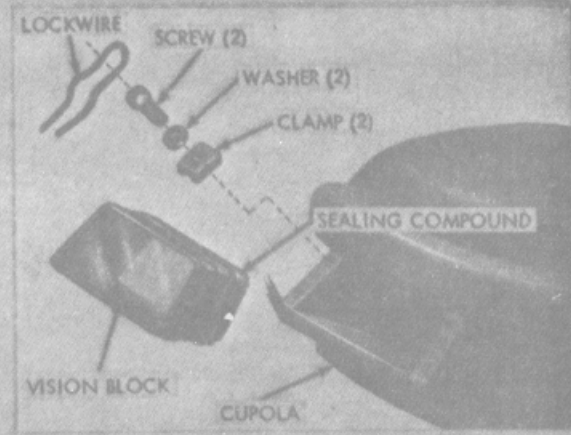
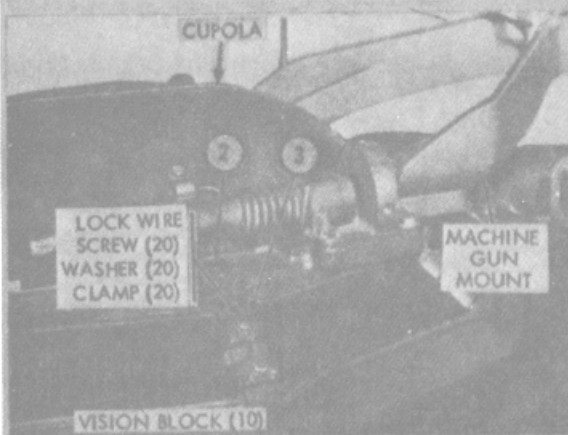

REMOVAL

1. REMOVE CAL 50 MACHINE GUN AND MOUNT (FIG. 2-4).
2. REMOVE 10 SCREWS AND CUPOLA RING WITH CUPOLA AND MACHINE GUN MOUNT.
3. REMOVE LOCK WIRE, TWO SCREWS, WASHER, AND CLAMPS FROM EACH SIDE OF VISION BLOCK.
4. REMOVE AS MUCH OF THE SEALING COMPOUND AS POSSIBLE AROUND THE BLOCK.
5. PUSH VISION BLOCK OUT FROM INSIDE OF CUPOLA.

**CAUTION:** DO NOT PUSH ON VISION BLOCK PROPER, USE VISION BLOCK CASING.

INSTALLATION

FOLLOW STEPS 3 THROUGH 1. MAKE CERTAIN VISION BLOCKS ARE SEALED THOROUGHLY WITH SEALING COMPOUND MIL-S-11031 APPLIED ON BOTH ENDS TO A MINIMUM OF ONE INCH WIDTH.

WE 70573

*Figure 10-49. Removal/installation - cupola vision blocks*

Pages 10-48.1 and 10.48.2 - deleted.

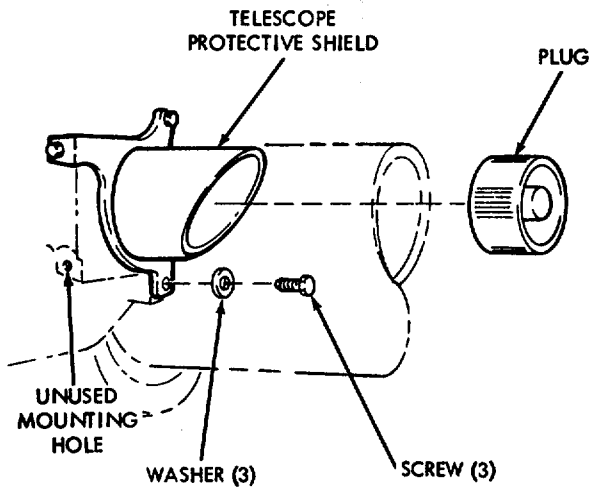

REMOVAL

REMOVE 3 SCREWS AND WASHERS, AND PROTECTIVE SHIELD.

INSTALLATION

REVERSE REMOVAL PROCEDURE. INSERT PLUG IN PROTECTIVE SHIELD WHEN TELESCOPE IS NOT IN USE.

NOTE. SCREW AND WASHER MUST BE MAINTAINED IN UNUSED MOUNTING HOLE TO PROTECT THREADS AND MOUNTING SURFACE.

WE 1218

Figure 10-49.1. Removal/installation - Telescope protective shield

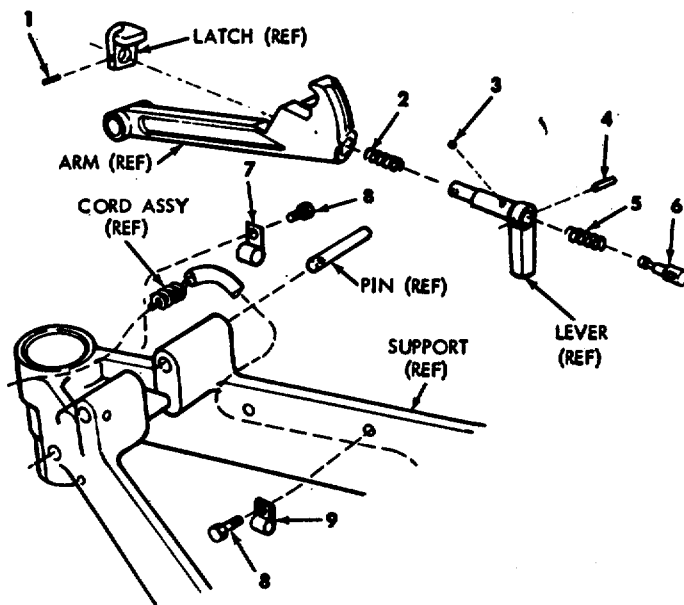

LEGEND

- 1. SPRING PIN
- 2. SPRING
- 3. BALL
- 4. SPRING PIN
- 5. SPRING
- 6. TRAVEL LOCK PLUNGER
- 7. CLAMP
- 8. SCREW
- 9. CLAMP

DISASSEMBLY/ASSEMBLY

REPLACE UNSERVICEABLE PARTS AS REQUIRED.

WE 11945

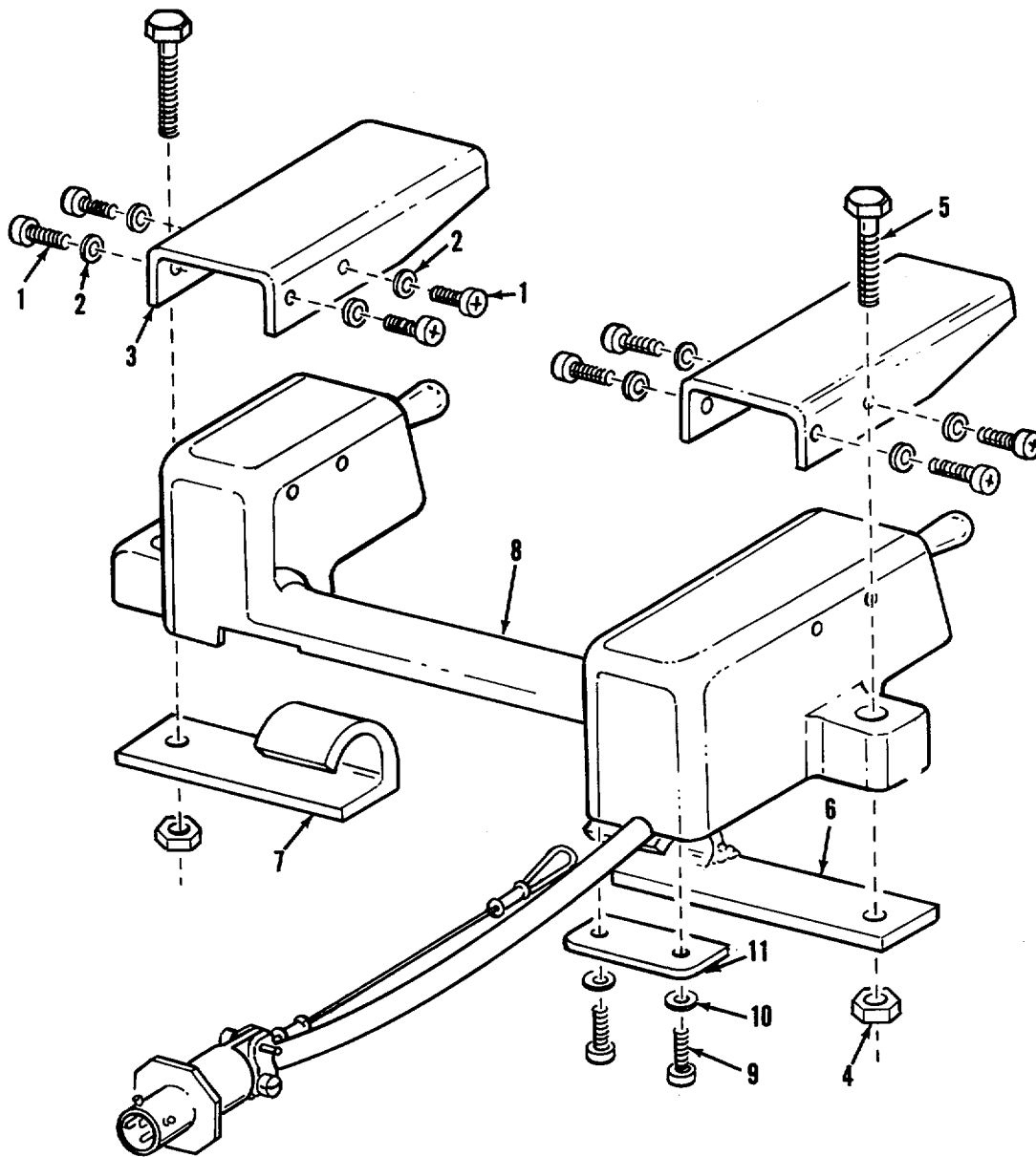

LEGEND

- |           |     |            |     |
|-----------|-----|------------|-----|
| 1. SCREW  | (8) | 7. PLATE   |     |
| 2. WASHER | (8) | 8. HOUSING |     |
| 3. GUARD  | (2) | 9. SCREW   | (2) |
| 4. NUT    | (2) | 10. WASHER | (2) |
| 5. SCREW  | (2) | 11. PLATE  |     |
| 6. PLATE  |     |            |     |

WE 73810 ■

Figure 10-49.2.1. Removal/installation - cupola traverse switch assembly.

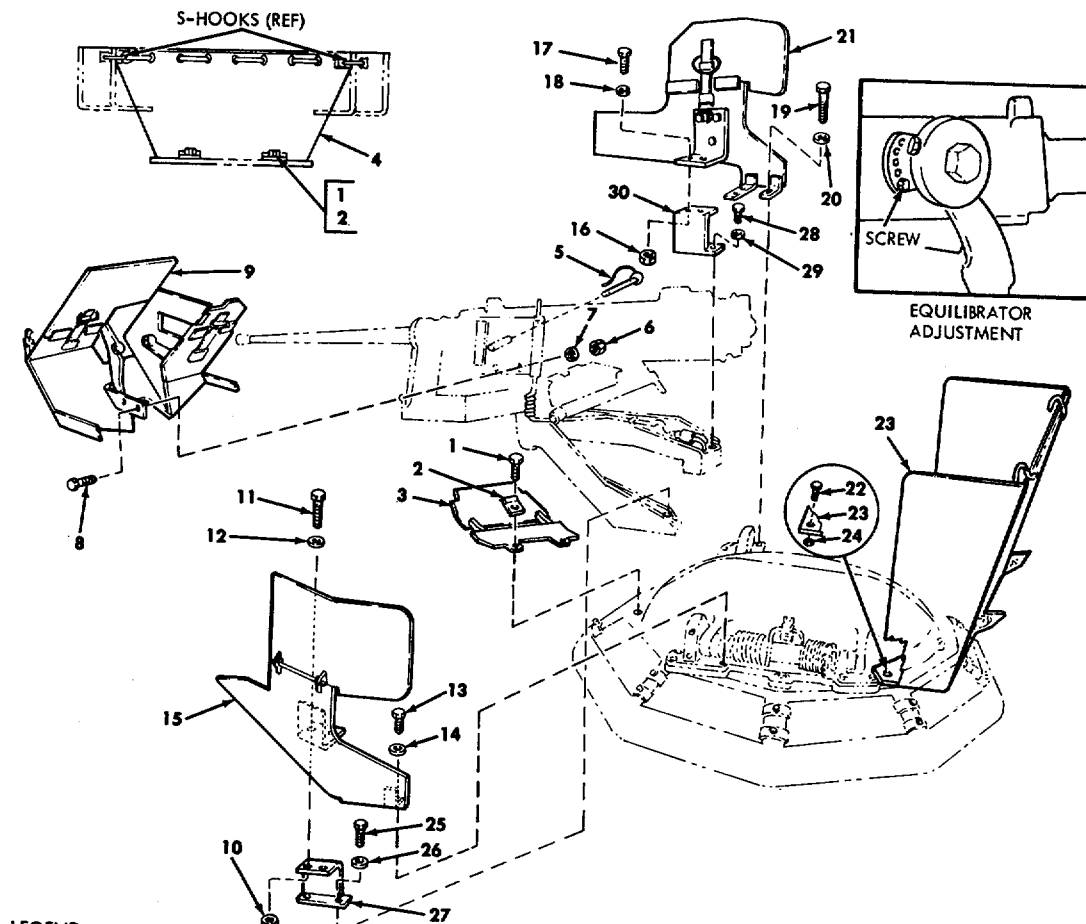

**LEGEND**

- |                            |                         |                         |                   |
|----------------------------|-------------------------|-------------------------|-------------------|
| 1. SCREW (2)               | 8. SCREW (2)            | 16. NUT (2)             | 24. SPACER (4)    |
| 2. CLIP (2)                | 9. FRONT PLATE ASSEMBLY | 17. SCREW (2)           | 25. SCREW (2)     |
| 3. BOTTOM PROTECTIVE COVER | 10. NUT (2)             | 18. WASHER (2)          | 26. WASHER (2)    |
| 4. SPENT BRASS DEFLECTOR   | 11. SCREW (2)           | 19. SCREW (3)           | 27. LEFT CHANNEL  |
| 5. LOCKING PIN             | 12. WASHER (2)          | 20. WASHER (3)          | 28. SCREW (2)     |
| 6. NUT (2)                 | 13. SCREW (3)           | 21. RIGHT PLATE ASSY    | 29. WASHER (2)    |
| 7. WASHER (2)              | 14. WASHER (3)          | 22. SCREW (4)           | 30. RIGHT CHANNEL |
|                            | 15. LEFT PLATE ASSY     | 23. REAR ENCLOSURE ASSY |                   |

**REMOVAL**

1. REMOVE AMMUNITION BOX AND TRAY (FIG. 2-4).
2. FOLLOW NUMERICAL SEQUENCE THROUGH ITEM 26.
3. REINSTALL ITEMS 25 AND 26 TO RETAIN PINTLE SUPPORT.
4. DISCONNECT ELECTRICAL CONNECTOR, AND REMOVE 2 SCREWS AND CONNECTOR BRACKET.
5. REMOVE ITEMS 27, 28 AND 29. REINSTALL ITEMS 27 AND 28 TO RETAIN PINTLE SUPPORT.
6. IF VEHICLE IS TO BE OPERATED WITH SHIELDS REMOVED:
  - a. REPLACE SCREWS REMOVED (ITEMS 1, 13, 19, 25, AND 28) WITH THOSE SPECIFIED IN TM 9-2350-230-25P/2.
  - b. REVERSE STEP 4 TO INSTALL ELECTRICAL CONNECTOR.
  - c. IDENTIFY AND PACKAGE ATTACHING HARDWARE FOR FUTURE USE.

**INSTALLATION**

- REVERSE REMOVAL PROCEDURE.
- TIGHTEN SCREWS (ITEMS 1 AND 22) TO 35-40 POUNDS-FOOT.
- TIGHTEN SCREWS (ITEMS 11 AND 17) TO 81-99 POUNDS-FOOT.
- TIGHTEN SCREWS (ITEMS 13 AND 19) TO 80-90 POUNDS-FOOT.
- TIGHTEN SCREWS (ITEMS 25 AND 28) TO 170-180 POUNDS-FOOT.

**EQUILIBRATOR ADJUSTMENT**

FOR OPERATION WITH COMMANDER'S BALLISTIC SHIELDS, EQUILIBRATOR LOCKING SCREW MUST BE INSTALLED IN LOWEST HOLE AS SHOWN IN INSET.

FOR OPERATION WITHOUT SHIELDS, INSTALL LOCKING SCREW TO OBTAIN BEST BALANCE OF GUN (NORMALLY IN SECOND HOLE FROM TOP).

AR 900061

Figure 10-49.3. Removal/installation - commander's ballistic shield plate assemblies (1 of 2).

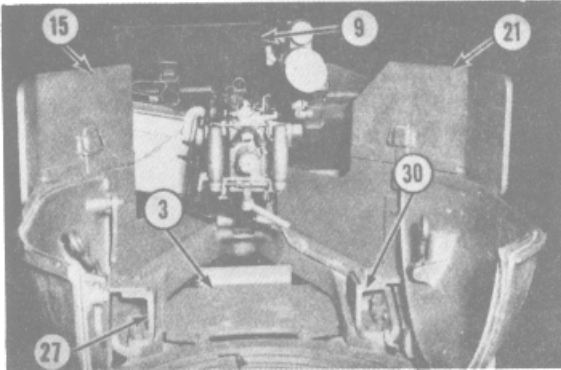

**SIDE AND FRONT SHIELDS INSTALLED**

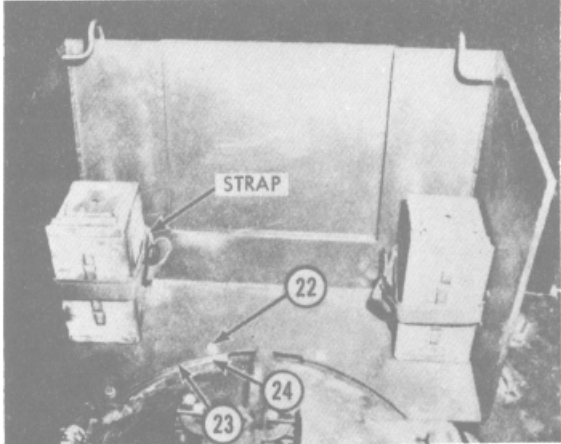

**REAR ENCLOSURE INSTALLED**

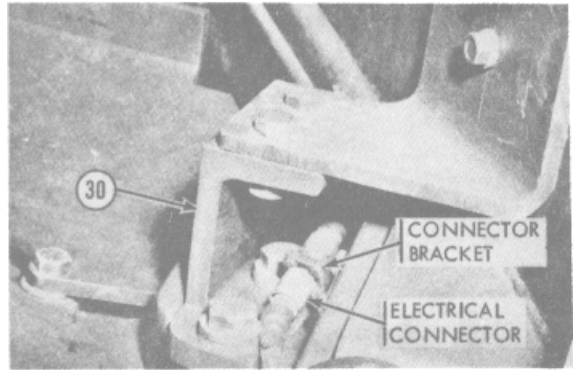

**ELECTRICAL CONNECTOR DETAIL**

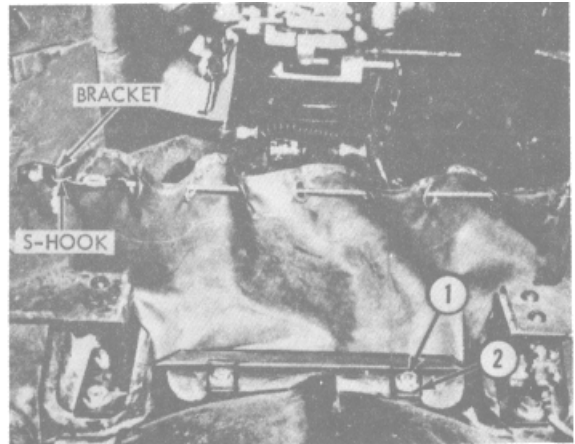

**SPENT BRASS DEFLECTOR INSTALLED**

**CIRCLED NUMBERS ABOVE REFER TO LEGEND, FIGURE 10-49.3**

*Figure 10-49.4. Removal/installation - commander's ballistic shield plate assemblies (2 of 2).*

**10-48.5**



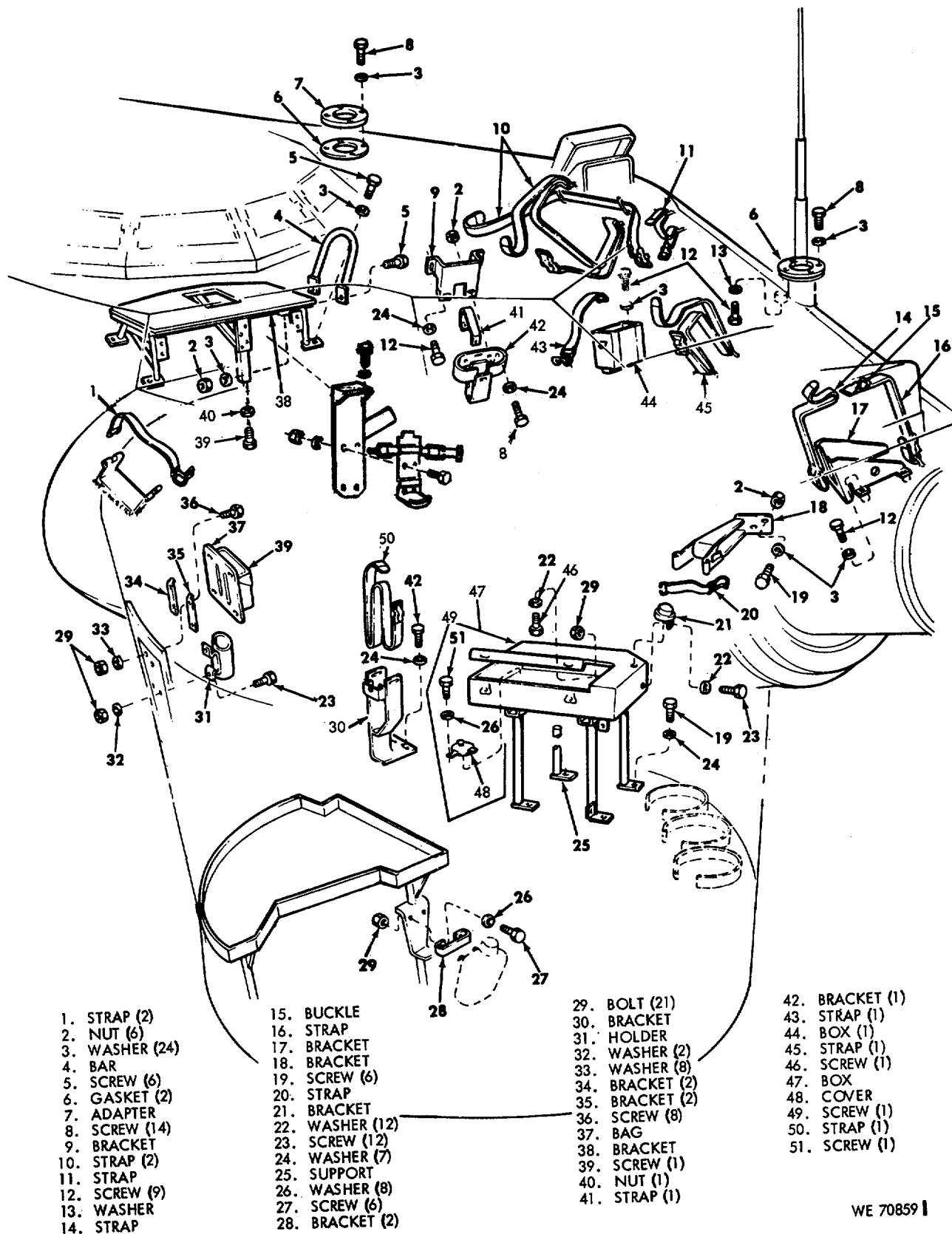

WE 70859 |

Figure 10-50. Turret interior stowage.

Figure 10-51 - deleted.

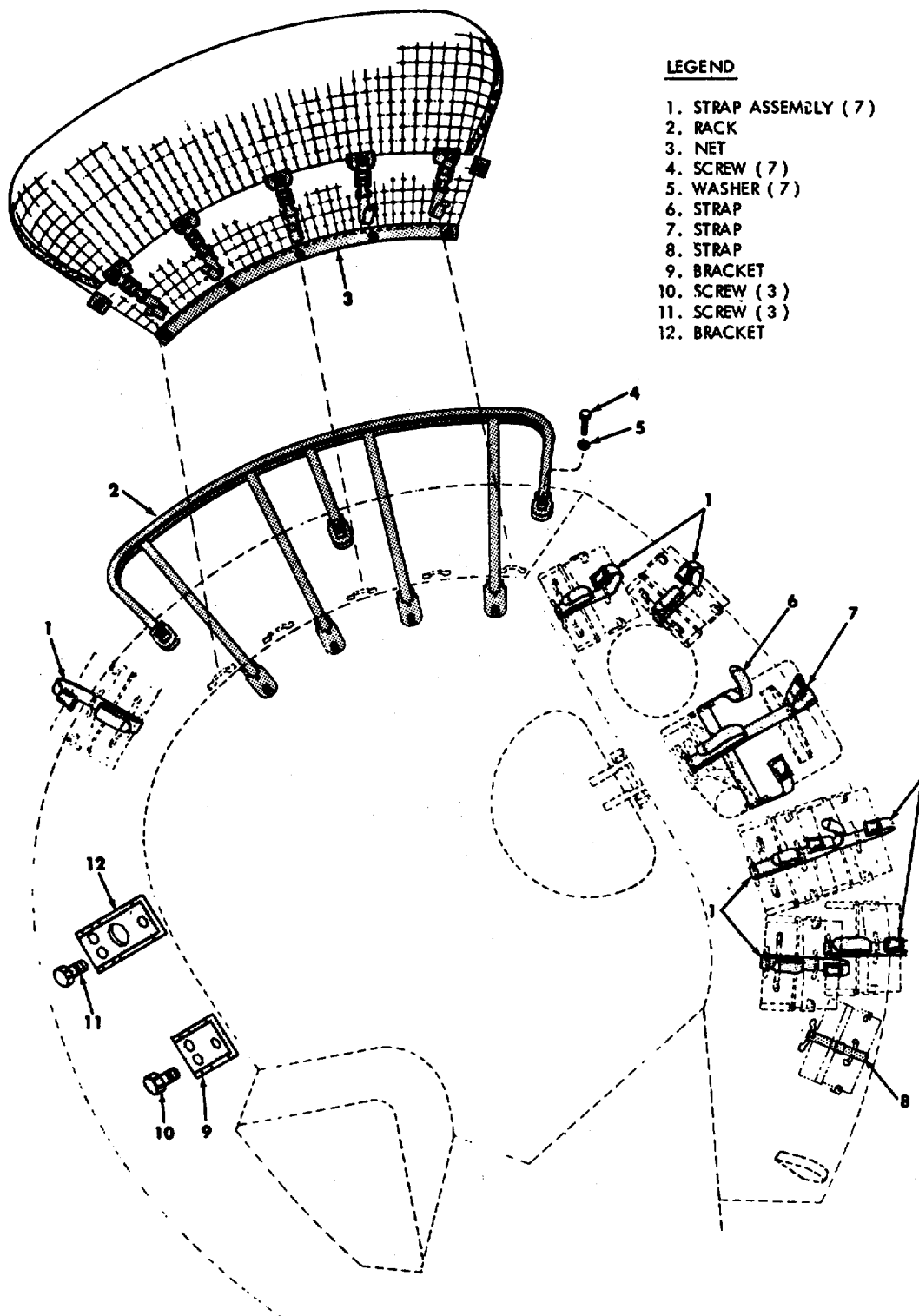

**LEGEND**

- 1. STRAP ASSEMBLY ( 7 )
- 2. RACK
- 3. NET
- 4. SCREW ( 7 )
- 5. WASHER ( 7 )
- 6. STRAP
- 7. STRAP
- 8. STRAP
- 9. BRACKET
- 10. SCREW ( 3 )
- 11. SCREW ( 3 )
- 12. BRACKET

WE 66714

Figure 10-52. Turret exterior stowage

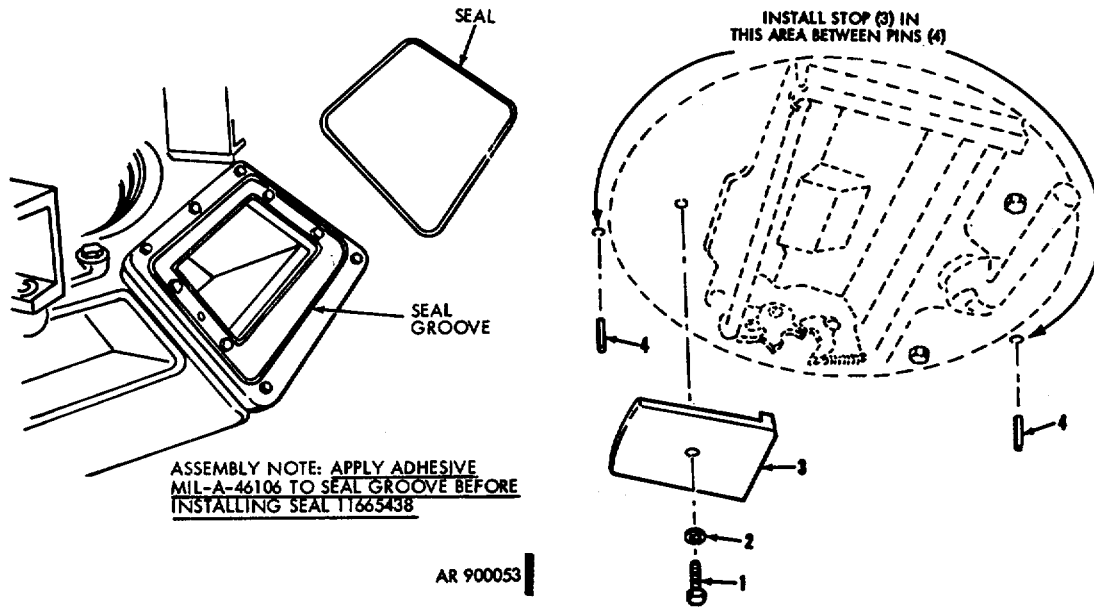

**Figure 10-53. Removal/installation - cupola seal for transceiver (M551A1 only).**

**REMOVAL SEQUENCE**

1. SCREW
2. WASHER
3. PERISCOPE STOP
4. PIN (2)

**INSTALLATION**

ROTATE LOADER'S PERISCOPE MOUNT TO ALLOW INSTALLATION OF STOP (3) BETWEEN THE PINS (4) AS INDICATED. REVERSE NUMERICAL SEQUENCE.

AR 900052

*Figure 10-54. Removal/installation - loader's periscope stop (M551A1 only).*

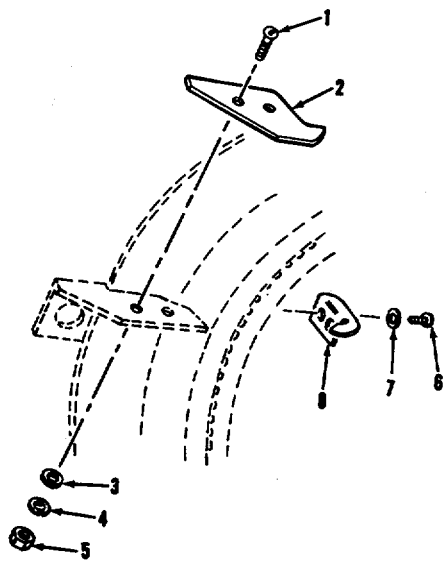

**REMOVAL SEQUENCE**

1. SCREW (2)
2. INDEX POINTER
3. WASHER (2)
4. WASHER (2)
5. NUT (2)
6. SCREW (2)
7. WASHER (2)
8. INDEX POINTER

**INSTALLATION**

TRAVERSE CUPOLA TO ALIGN LASER RANGE FINDER WITH GUN-LAUNCHER, REVERSE NUMERICAL SEQUENCE.

AR 900048

Figure 10-55. Removal/installation - index pointers (M551a1 only).

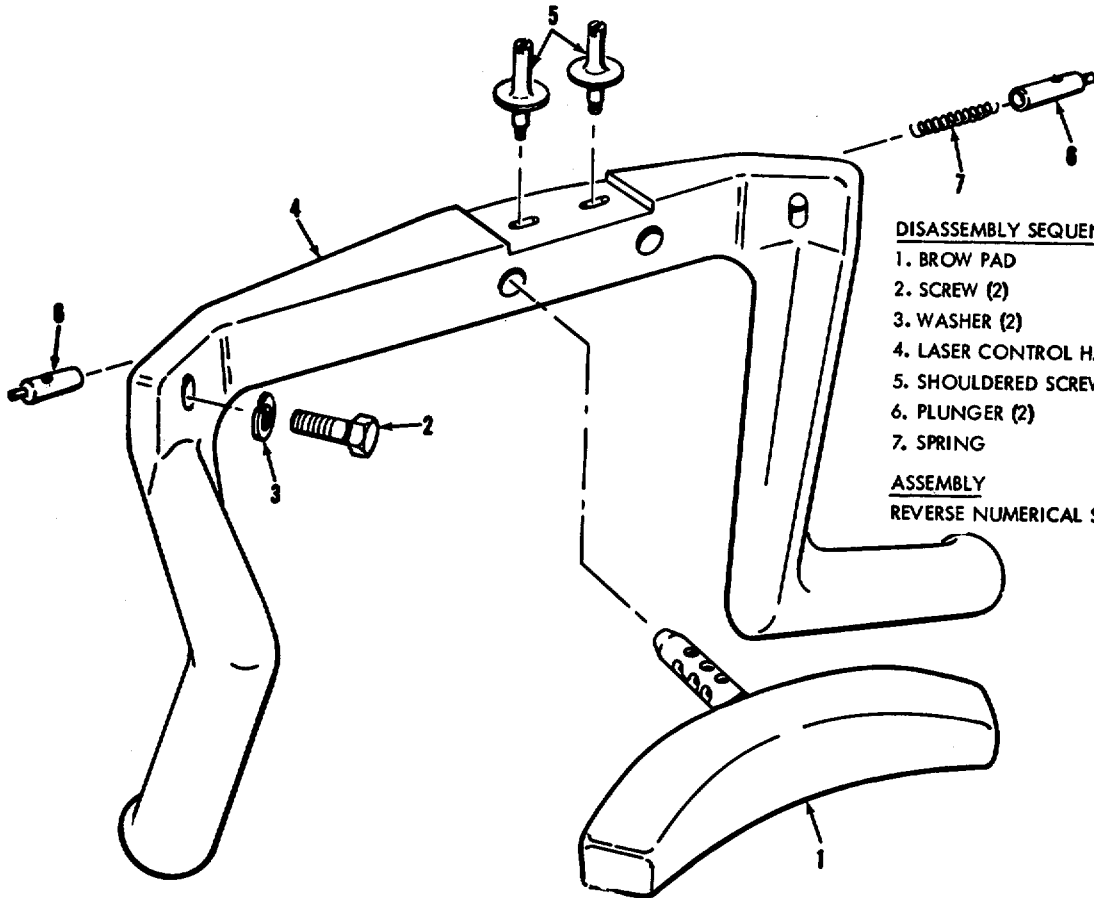

**DISASSEMBLY SEQUENCE**

1. BROW PAD
2. SCREW (2)
3. WASHER (2)
4. LASER CONTROL HANDLE
5. SHOULDERED SCREW (2)
6. PLUNGER (2)
7. SPRING

**ASSEMBLY**

REVERSE NUMERICAL SEQUENCE

AR 900049

Figure 10-56. Removal/ installation - laser control handle (M551A1 only).

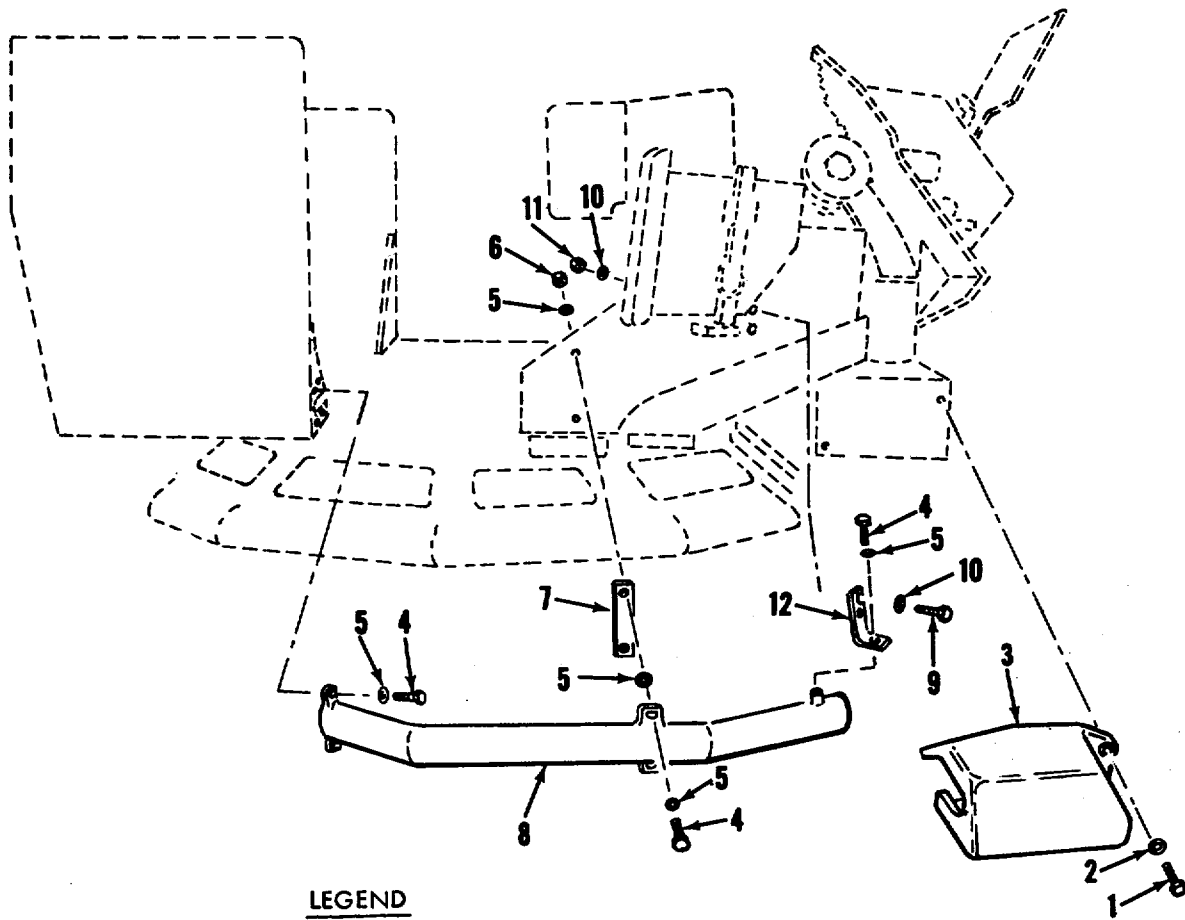

**LEGEND**

- |                    |                   |
|--------------------|-------------------|
| 1. SCREW (2)       | 7. SPACER         |
| 2. WASHER (2)      | 8. CABLE COVER    |
| 3. CONNECTOR COVER | 9. SCREW (2)      |
| 4. SCREW (5)       | 10. WASHER (4)    |
| 5. WASHER (9)      | 11. NUT (2)       |
| 6. NUT (2)         | 12. ANGLE BRACKET |

AR 900046

Figure 10-57. Removal/installation - cable covers (M551A1 only).

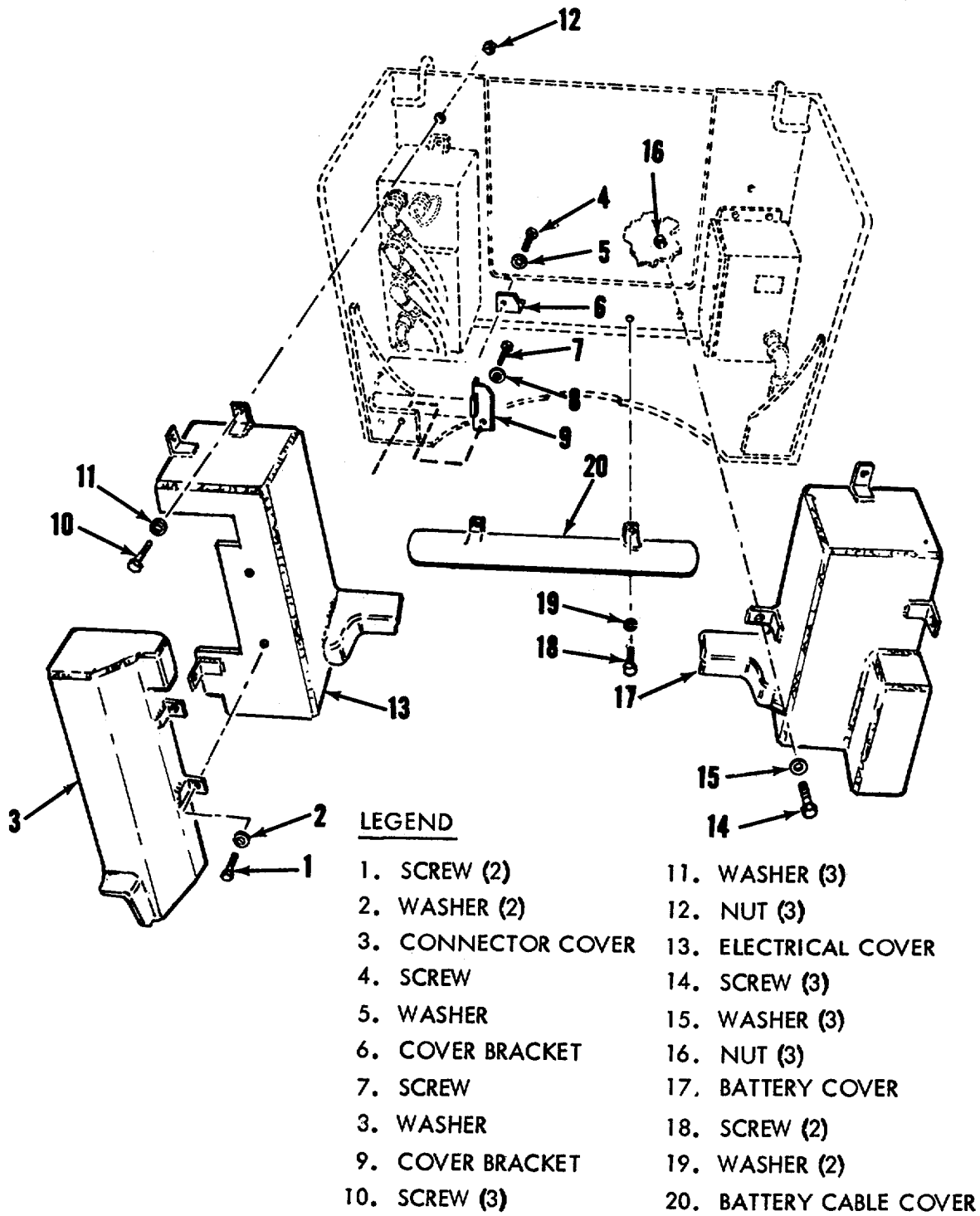

AR 900051

Figure 10-58. Removal/installation - electronics unit and power supply covers (M551A1 only).



**CHAPTER 11  
ORGANIZATIONAL MAINTENANCE-ARMAMENT  
AND FIRE CONTROL**

**Section 11-1. PRIMARY ARMAMENT**

**11-1. General**

a. Table 11-1 lists components of the M81 modified and M81E1 gun-launcher, including the compressed air closed-breech scavenging system, and mount which are serviced by organizational maintenance personnel.

b. Refer to figures 11-1 and 11-11 for locational reference and component identification.

C "Prevailing Torque", as used in this chapter, is the force required to turn a self-locking screw or nut in/on its mating threads before the screw head or nut comes in contact with the surface against which it is being tightened. It is a result of the self-locking feature of the screw or nut.

To simplify maintenance procedures, allowance for prevailing torque, where applicable, has been incorporated in torque values specified. Torque values which include prevailing torque are so identified in the instructions.

**TABLE 11-1. PRIMARY ARMAMENT**

ASSEMBLY OR COMPONENT	FIGURE REFERENCE		
	ADJUST	REMOVE/ INSTALL	REPAIR
Firing Mechanism Continuity Check-Table 11-2	11-1.4		
Firing Mechanism Continuity	11-2	11-2	
Counterrecoil Buffer and In-Battery Limit Switch		11-3	
7.62-MM Machine Gun Mount		11-4	
7.62-MM Machine Gun Spent Brass Chute and Bag		11-5	11-5
Recoil Mechanism Hand Pump and Hydraulic Fittings			
Filling and Bleeding Recoil Hydraulic System	Table 11-2.2		
Buffer Bleed Line		11-5.1	
Recoil Guard Cover and Screen		11-6	
Recoil Mechanism Reservoir Components		11-7,	11-7,
11-8		11-8	
Breech Scavenging Check Valve		11-10.1	11-10.2, 11-10.3
CBSS Slaving System		11-10.1.1	
Wiring Harness Assembly		11-12	
Breech Open/Closed Switches		11-12	
Firing Mechanism		11-13	
Electric Drive Motor		11-14	
Electric Drive Solenoid		11-15	
Loading Tray and Bracket Assembly		11-16	11-17, 11-18; 11-19
Loading Tray and Ejector	11-20		
Loading Tray Guide	11-21	11-21	
Ejector Cocking Bracket	11-21	11-21	
Ammunition Detent	11-23	11-22	
Obturator Gasket		11-24	
Carrier Cover Vent Plug		11-25	
Manual Drive Crank Handle		11-25	



TABLE 11-2. FIRING MECHANISM CONTINUITY CHECK

STEP	PROCEDURE
1	Remove guard, upper harness clamp, and electrical connector from firing mechanism receptacle (fig. 11-1.4).
2	Open breech chamber and short the firing mechanism tip to firing mechanism collar or breech chamber. <b>NOTE:</b> <u>Firing mechanism tip can be shorted to collar by wrapping lockwire around the tip and firing mechanism collar.</u>
3	Manually close breech until scribe line on breech chamber is between the "SAFE" scribe lines on coupling.
4	Connect a continuity light or multimeter to the two pins in firing mechanism receptacle.
5	Circuit between receptacle pins must show continuity, if not adjust receptacle (fig. 11-1.4 ).
6	If light or meter indicates continuity, remove light and open breech. Remove shorting wire and install harness connector, harness clamp, and guard.

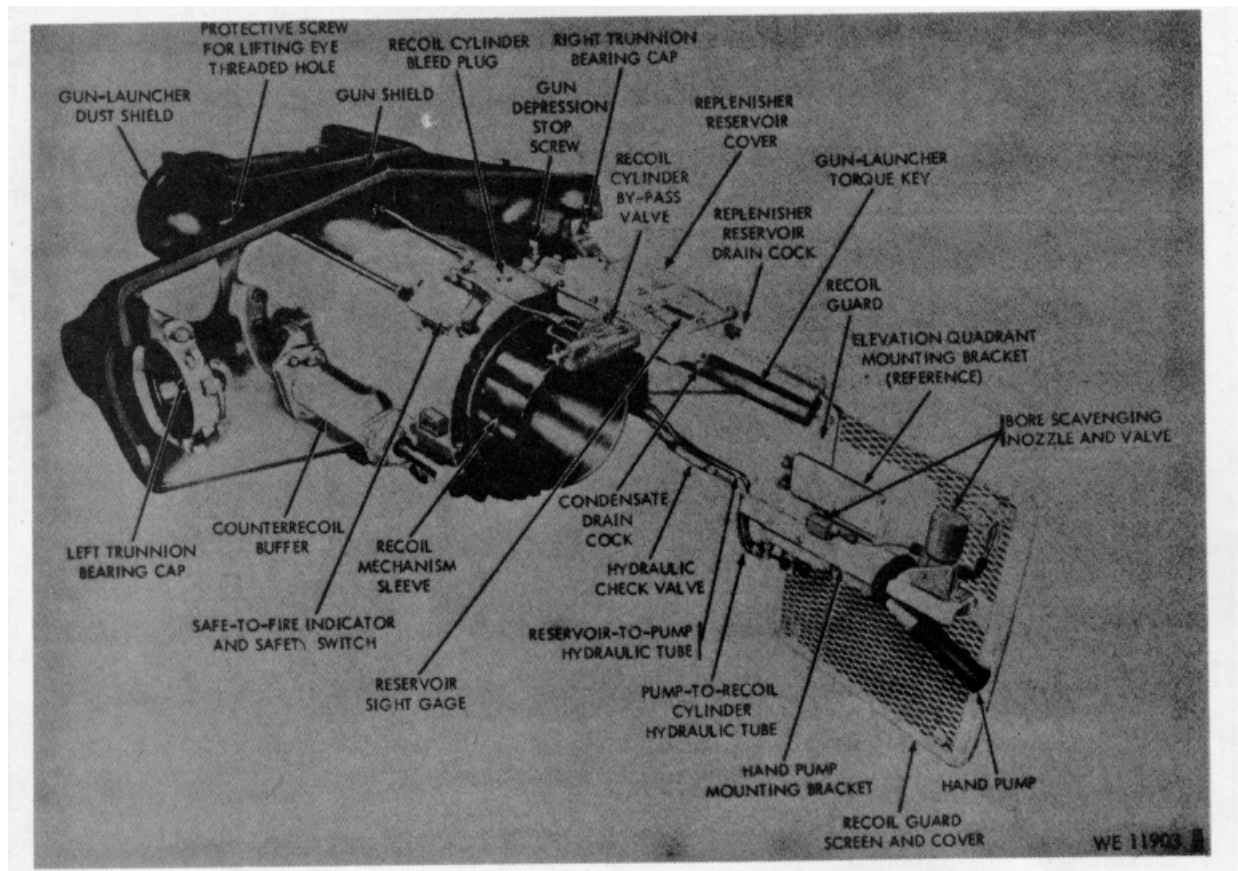

Figure 11-1. Gun mount assembly for gun-launcher - locational reference.

Figures 11-1.1, 11-1.2, and 11-1.3 deleted.

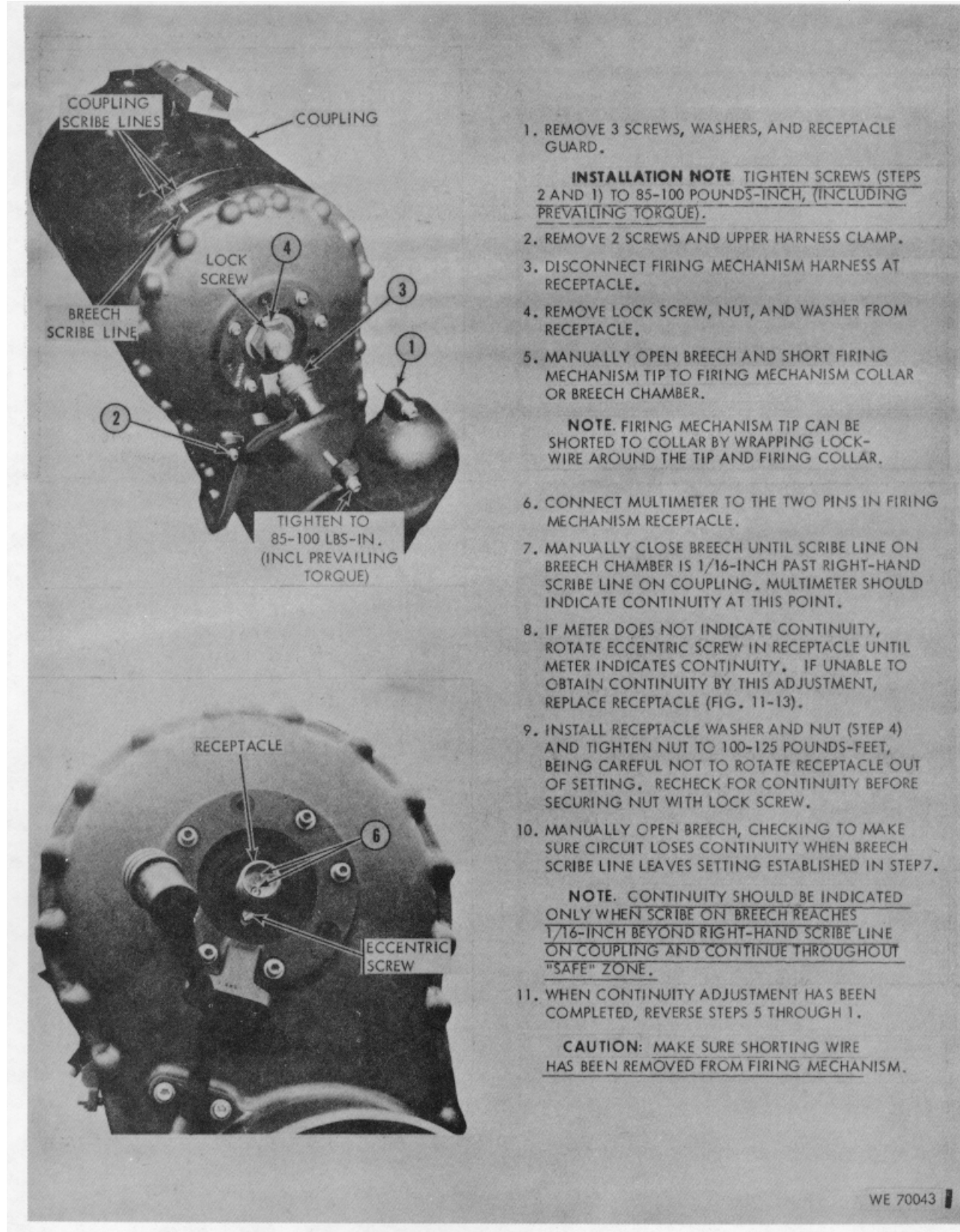
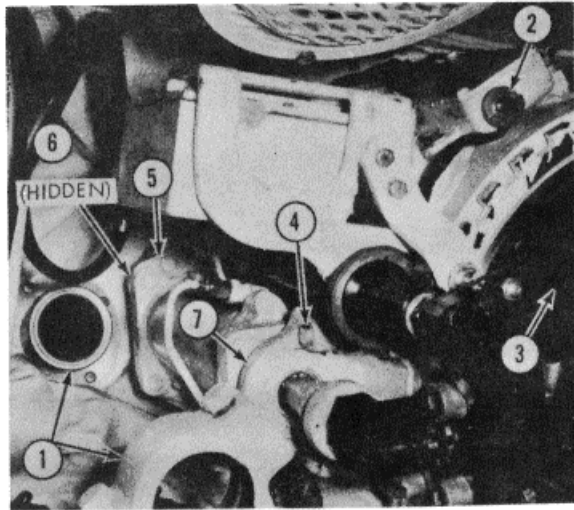

Figure 11-1. 4. Adjusting firing mechanism receptacle for continuity.



**REMOVAL**

1. REMOVE 7.62MM MACHINE GUN (FIG. 3-7).
2. RELEASE HYDRAULIC PRESSURE FROM RECOIL CYLINDER (FIG. 3-2).
3. MOVE GUN-LAUNCHER OUT OF BATTERY TO RELEASE SPRING PRESSURE IN BUFFER.
4. REMOVE 2 SCREWS FROM REAR BUFFER BRACKET.

**NOTE.** IF EQUIPPED WITH BUFFER BLEED LINE, REMOVE AND PLUG BLEED LINE (FIG. 11-5.1).

5. REMOVE 2 FRONT SCREWS, WASHERS, AND COUNTER RECOIL BUFFER.
6. REMOVE REAR BRACKET FROM BUFFER AND REINSTALL ON RECOIL CYLINDER.

**M81 ONLY:**

7. REMOVE ATTACHING NUT AND IN-BATTERY LIMIT SWITCH.
8. REMOVE 2 SCREWS, WASHERS, AND SWITCH BRACKET.

**INSTALLATION**

1. REVERSE REMOVAL PROCEDURE.
2. ADJUST PRECHARGE PRESSURE IN RECOIL CYLINDER (FIG. 3-2).
3. ADJUST IN-BATTERY LIMIT SWITCH.

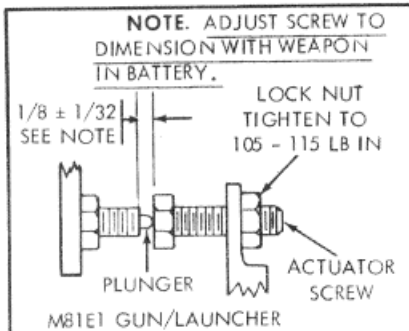

**IN-BATTERY LIMIT SWITCH ADJUSTMENT**

(SEE INSETS AT LEFT)

1. LOOSEN LOCK NUT AND ADJUST ACTUATOR SCREW TO DIMENSION SHOWN.
2. HOLD ACTUATOR SCREW WHILE TIGHTENING LOCK NUT.

**NOTE.** WASHER MS27183-18 (.121 THICK) FSN 5310-809-5998 MAY BE USED AS THICKNESS GAGE WHEN MAKING THIS ADJUSTMENT (TM 9-2350-230-25P/2).

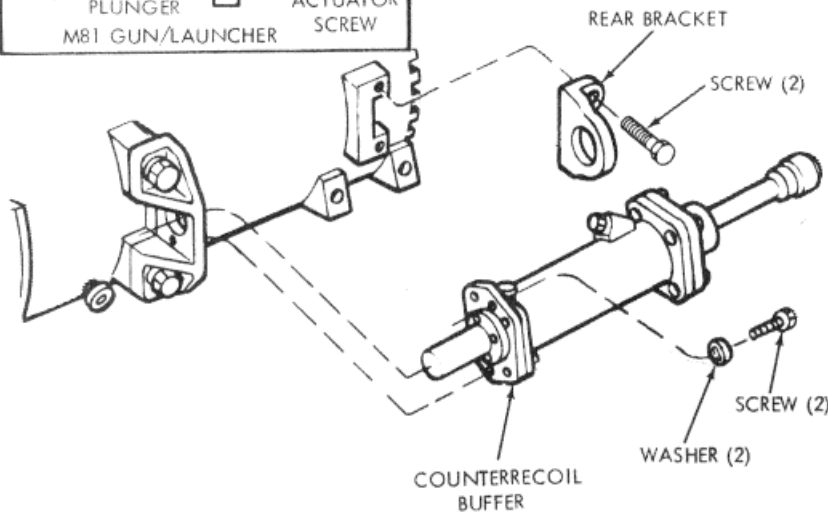
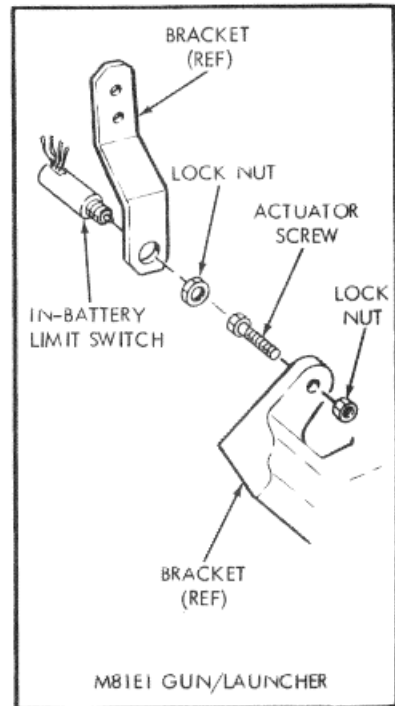
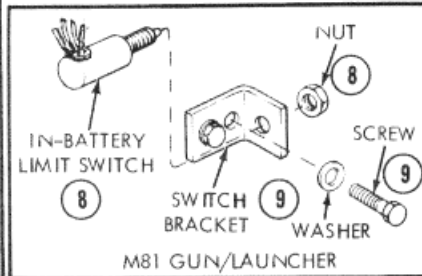
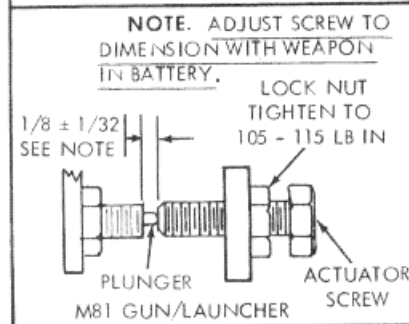

WE 66582

Figure 11-2. Removal/installation - counterrecoil buffer, and adjusting in-battery limit switch

TABLE 11-2.1. PROCEDURE FOR CYCLING CBSS

STEP	PROCEDURE
1	Check oil in air compressor.
2	Turn on compressor and fill air bottles.
3	Turn manual shut off valve to "ON" position.
4	Remove one mounting screw and loosen the other screw of the in-battery switch bracket, and swing up out of contact with the actuator screw (see fig. 11-2). <b>NOTE.</b> Do not disturb the setting of switch attachment to bracket.
5	To cycle CBSS, depress plunger of in-battery switch. <b>WARNING:</b> When 1.7 second surge of air is completed the breech chamber opens automatically. All personnel must make certain to stand clear to prevent injury.
6	After completion of CBSS cycling SHUT OFF turret power and return in-battery switch bracket to original position, replace screws, and tighten.

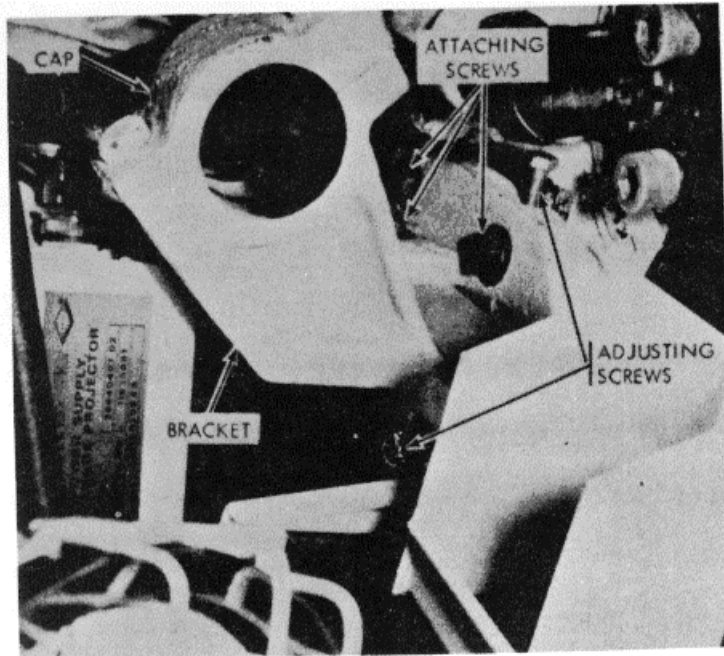
LEGEND

1. ADJUSTING SCREW (4)
2. SCREW (2)
3. WASHER (2)
4. SCREW (4)
5. BRACKET
6. PIVOT (2)
7. BRACKET
8. SPRING PIN
9. CAP

COAXIAL MACHINE GUN MOUNT - GUN REMOVED

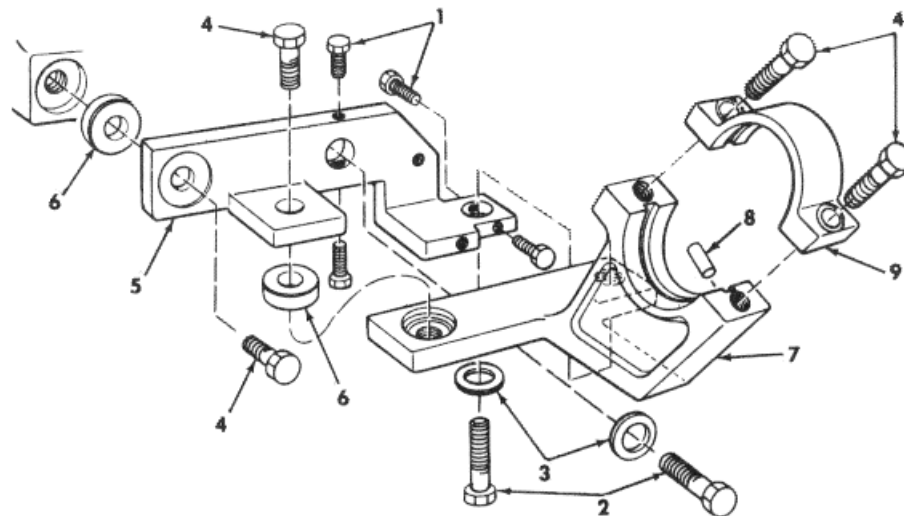
PRELIMINARY STEPS

1. REMOVE 7.62MM MACHINE GUN (FIG. 3-7).
2. REMOVE SPENT BRASS CHUTE (FIG. 11-4).
3. LOOSEN FOUR ADJUSTING SCREWS (1) BEFORE REMOVING ATTACHING SCREWS (2) AND (4).

REMOVAL

1. REMOVE TWO ATTACHING SCREWS, ONE FLAT WASHER, AND MOUNT COMPLETE.
2. REPLACE UNSERVICEABLE COMPONENTS AS REQUIRED.

INSTALLATION

1. REVERSE REMOVAL PROCEDURE.
2. REFER TO FIGURE 2-24 FOR ALIGNMENT OF 7.62MM MACHINE GUN AFTER INSTALLATION.

WE 66565

**Figure 11-3. Removal/Installation-7.62mm machine gun mount**

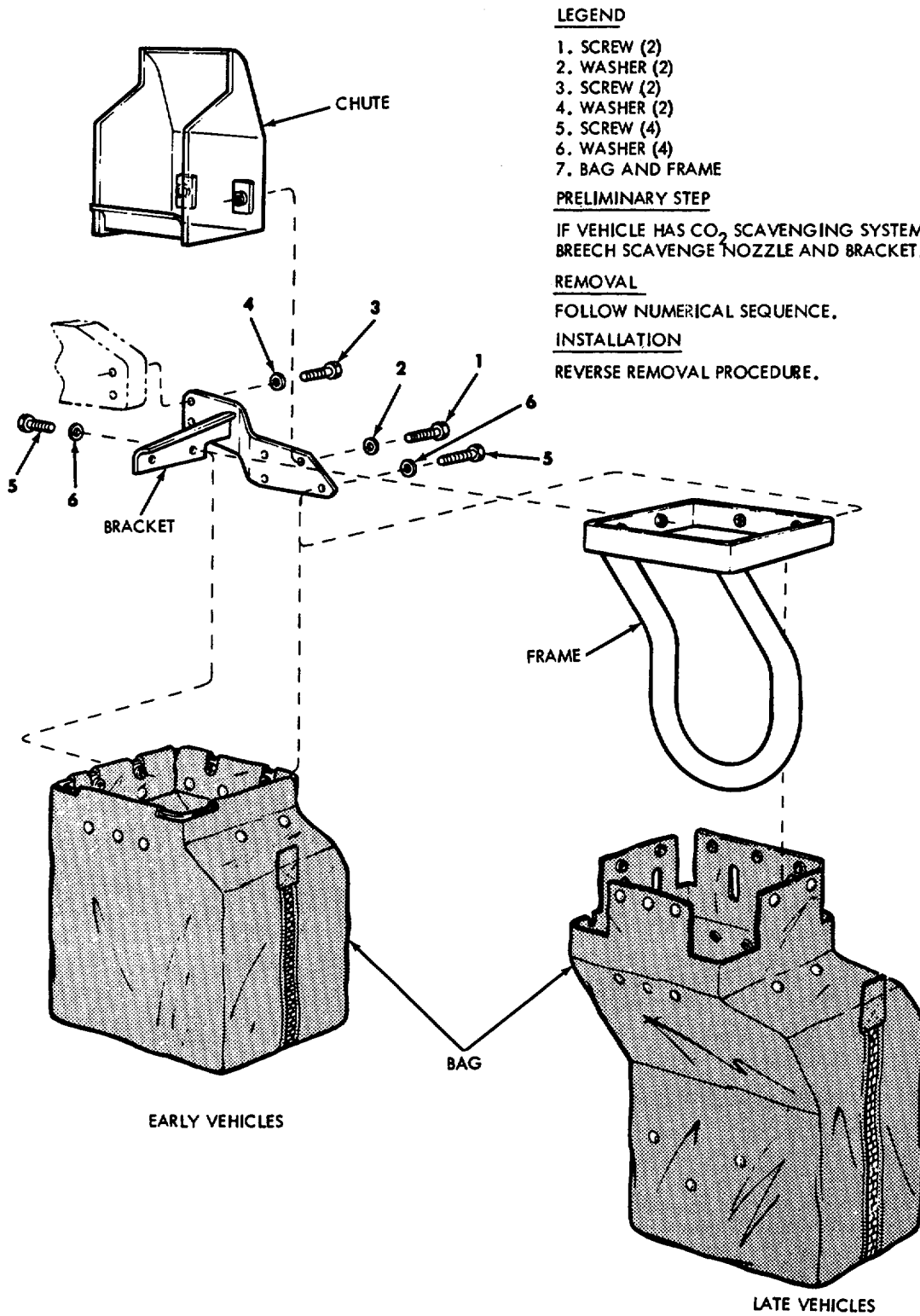

WE 11308A

Figure 11-4. (Superseded) Removal/installation - M73 machine gun ammunition spent brass chute and bag

C8, TM 9-2350-230-12

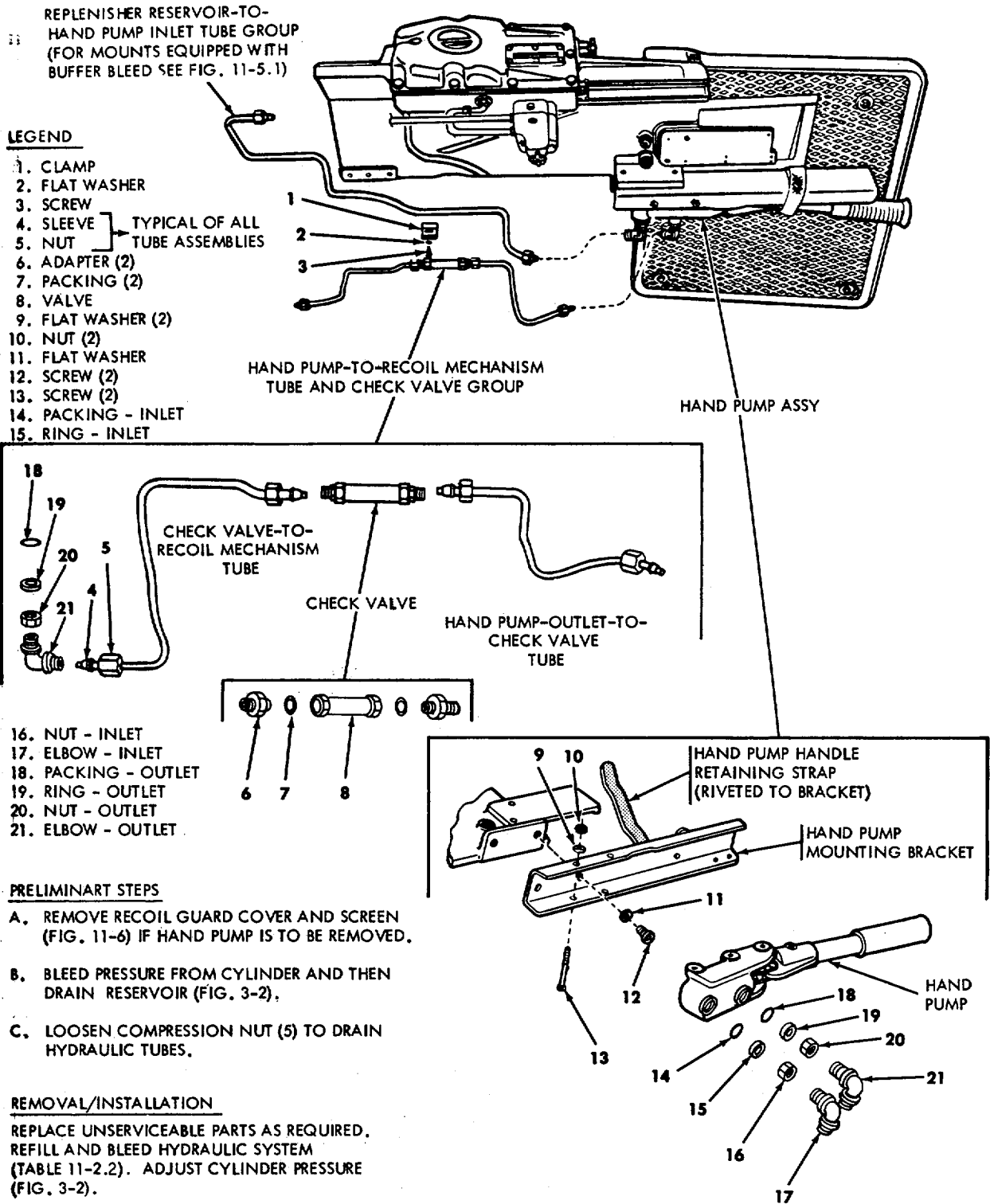

WE 66607

Figure 11-5. Removal/installation - recoil mechanism hand pump and hydraulic fittings

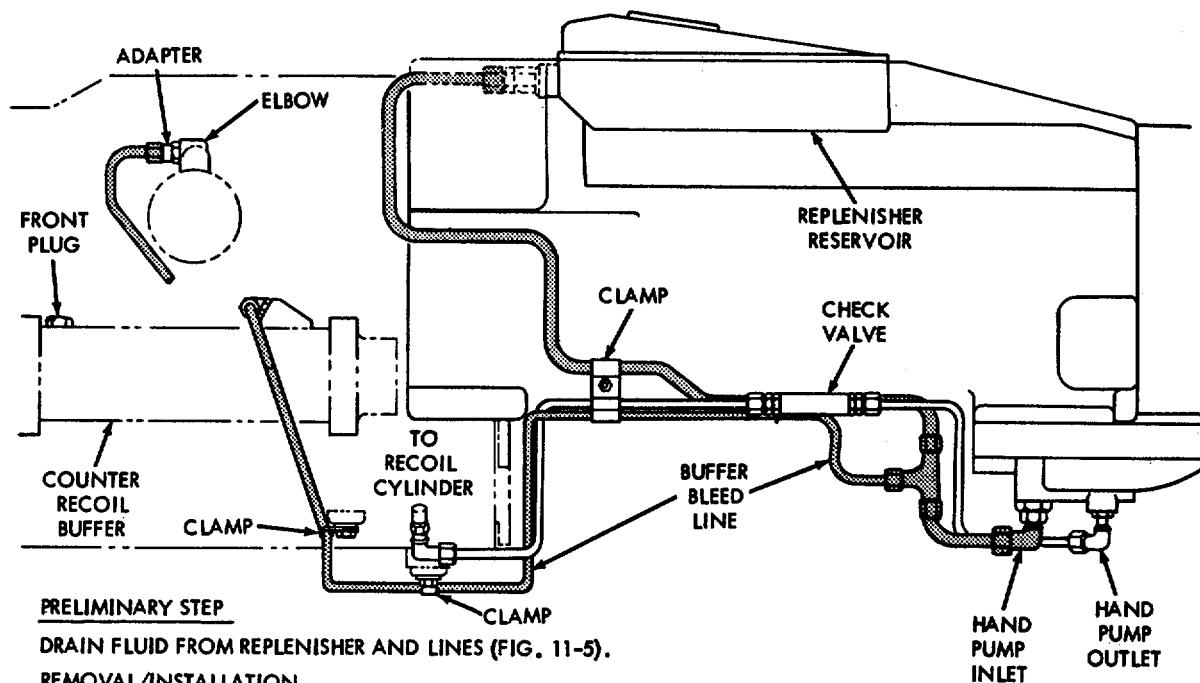

WE 11960

Figure 11-5.1. Removal/Installation - buffer bleed line

TABLE 11-2.2 FILLING AND BLEEDING GUN MOUNT HYDRAULIC SYSTEM

STEP	PROCEDURE
	<b>NOTE.</b> Refer to figure 3-2.
1	Position gun at zero elevation. Remove plug from top rear port on recoil cylinder and disconnect bleed line at elbow fitting to exhaust air while filling recoil mechanism.
2	Disconnect hand pump outlet-to-check valve pressure line at check valve on bottom rear of recoil guard.
3	Connect a separate hydraulic fluid supply to check valve, depress recoil mechanism 3-5 degrees and fill with hydraulic fluid filtered to 5 microns, Specification MIL-H-6083 (OHC).
4	When fluid flows from elbow fitting, reconnect bleed line. Continue filling until fluid flows from top rear port.
5	Install plug in top rear port.
6	Elevate recoil mechanism to zero degrees. Remove filling plug in top of replenisher reservoir. Open manual bleed valve and continue filling until replenisher reservoir fluid level is at bottom of filling plug opening. Reinstall filling plug.
7	Operate replenisher pump until clear fluid flows from pump pressure line. This will fill and bleed suction line, pump assembly, and pressure line.
7.1	Units with buffer bleed: Remove front plug from counter recoil buffer to bleed air from buffer. Replace plug when oil flows out. Check oil level in replenisher and repeat step 6 if required.
8	Remove connection from separate fluid supply and re-attach hand pump pressure line to check valve.
9	Operate hand pump several times to remove any additional air in suction and pressure lines. Depress recoil mechanism 5 degrees and let stand for 20 minutes. At end of this time, crack plug in top rear port and bleed off any additional entrapped air by operating hand pump.



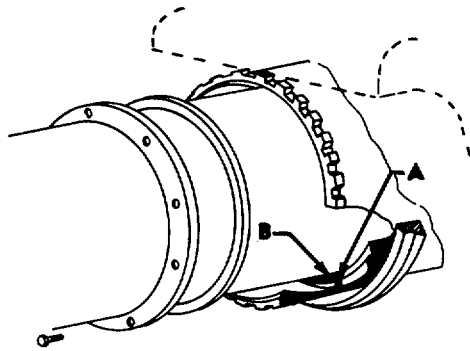

FLUID LEAKAGE POINTS  
MUZZLE END

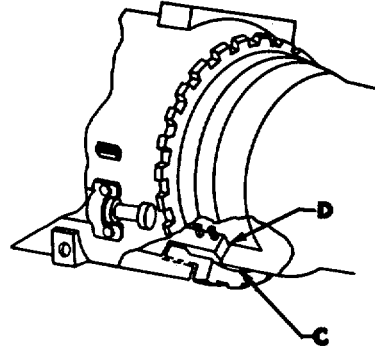

FLUID LEAKAGE POINTS  
BREECH END

**NOTE. DURING FIRING EXERCISES HYDRAULIC FLUID IS FORCED PAST THE FRONT AND REAR FOLLOWER SEALS AND AN ACCUMULATION OF FLUID WILL BE NOTED AT FRONT AND REAR OF GUN MOUNT. THIS IS NORMAL AND DOES NOT INDICATE NEED TO REPLACE SEALS.**

**LEAK-TEST PROCEDURE**

1. POSITION GUN MOUNT AT 0 DEGREES ELEVATION. (MOUNT SHOULD BE ALLOWED TO SET FOR THREE HOURS AFTER LAST FIRING FOR TEMPERATURE STABILIZATION).
2. APPLY PROPER PRECHARGE PRESSURE TO HYDRAULIC SYSTEM, (FIG. 3-2).
3. WIPE GUN MOUNT RESERVOIR AND ALL ADJACENT SURFACES. (RESERVOIR MAY HAVE OVERFLOWED DUE TO OVERFILLING OR FLUID EXPANSION DURING FIRING. THIS OVERFLOW MAY CAUSE ACCUMULATION OF FLUID ON MOUNT).
4. REMOVE DUST SHIELD SO THAT FRONT FOLLOWER AREA IS VISIBLE. (FLUID MAY FLOW FROM DUST COVER MOUNTING SCREW HOLES BUT FLOW SHOULD STOP AFTER A FEW MINUTES).

5. WIPE FRONT AND REAR FOLLOWER AREAS CLEAN OF ALL FLUID. OBSERVE FOR FLUID DRIPPING OR FLOWING FROM FRONT FOLLOWER (POINTS A AND B) AND REAR FOLLOWER (POINTS C AND D).

**NOTE. 1. IF THE DRIP RATE IS 5 DROPS/MINUTE OR MORE OVER A 1 HOUR PERIOD OR THE ACCUMULATION IS MEASURED AS 3 OZ. OVER A 12 HOUR PERIOD, THE GUN MOUNT IS LEAKING AND SEALS REQUIRE REPLACEMENT. NOTIFY SUPPORT MAINTENANCE.**

**2. IF FLOW OR CONSTANT DRIPPING IS NOTED THROUGH DUST SHIELD SCREW HOLE (POINT A), ONE OR BOTH BELLEVILLE PISTON SEALS ARE LEAKING AND REQUIRE REPLACEMENT. NOTIFY SUPPORT MAINTENANCE.**

6. IF LEAKAGE RATE AT BOTH FRONT AND REAR FOLLOWER AREAS WAS LESS THAN NOTED ABOVE, OVERFILLING OF RESERVOIR SHOULD BE CONSIDERED AS PROBABLE CAUSE FOR FLUID ACCUMULATION (SEE STEP 3). ADHERE STRICTLY TO FILLING PROCEDURE GIVEN IN FIGURE 3-2.

**CAUTION: BE SURE TO ELEVATE GUN-LAUNCHER TO 265 MILS BEFORE CHECKING RESERVOIR LEVEL.**

WE 12132

Figure 11-5. 2. Leak test procedure - gun mount hydraulic system

**LEGEND**

- 1. NUT (4)
- 2. FLAT WASHER (8)
- 3. RUBBER WASHER (4)
- 4. SCREW (4)
- 5. NUT (2)
- 6. FLAT WASHER (2)
- 7. SCREW (2)
- 8. NUT (2)
- 9. FLAT WASHER (2)
- 10. SCREW (2)
- 11. SCREW (2)
- 12. FLAT WASHER (2)

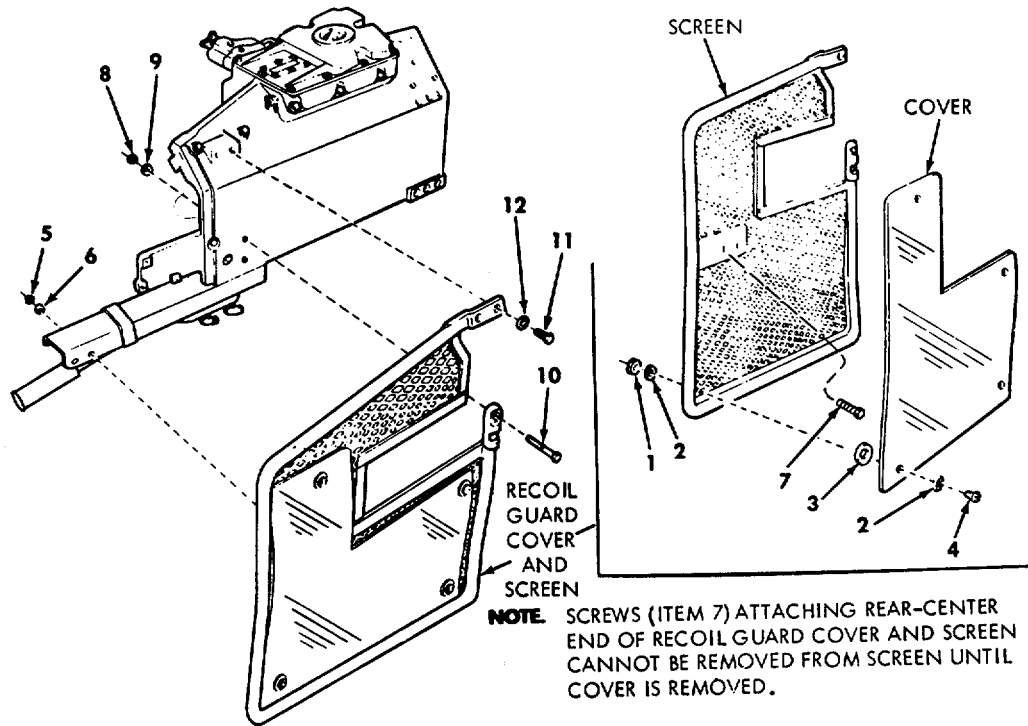

WE 70039

Figure 11-6. Removal/installation - recoil guard cover and screen

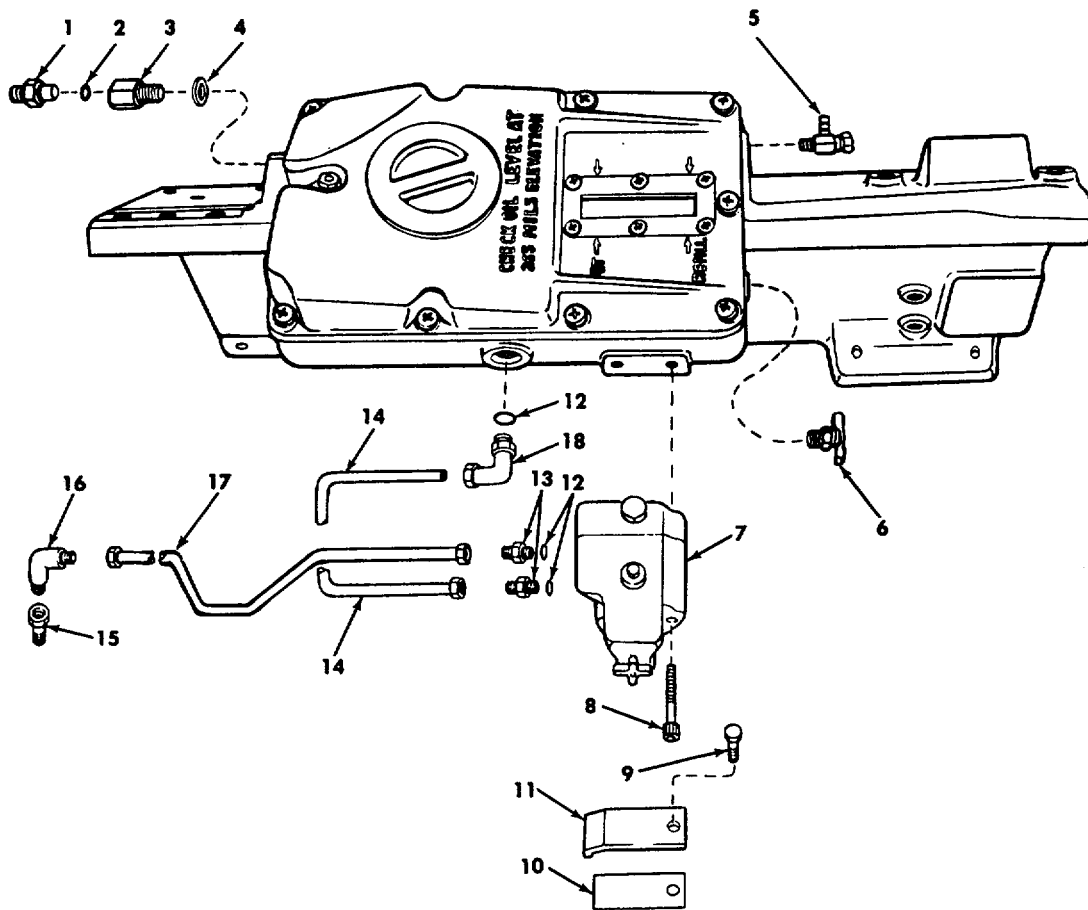

#### LEGEND

- |                            |               |
|----------------------------|---------------|
| 1. ADAPTER                 | 11. CAM       |
| 2. PACKING                 | 12. PACKING   |
| 3. ADAPTER                 | 13. ADAPTER   |
| 4. WASHER                  | 14. TUBE      |
| 5. DRAIN COCK (RESERVOIR)  | 15. ADAPTER   |
| 6. DRAIN COCK (CONDENSATE) | 16. ELBOW     |
| 7. VALVE ASSY              | 17. TUBE ASSY |
| 8. SCREW (2)               | 18. ELBOW     |
| 9. SCREW                   |               |
| 10. SHIM                   |               |

#### REMOVAL/INSTALLATION

ATTACH DRAIN HOSE TO DRAIN COCK (5), OPEN DRAIN COCK, BLEED VALVE (7), AND DRAIN RECOIL CYLINDER AND RESERVOIR. REPLACE UNSERVICEABLE PARTS AS REQUIRED. INSTALL NEW PACKING. REFILL AND BLEED HYDRAULIC SYSTEM (TABLE 11-2.2) AND ADJUST CYLINDER PRESSURE (FIG. 3-2).

WE 66680

Figure 11-7. Removal/installation - recoil mechanism reservoir components (1 of 2)

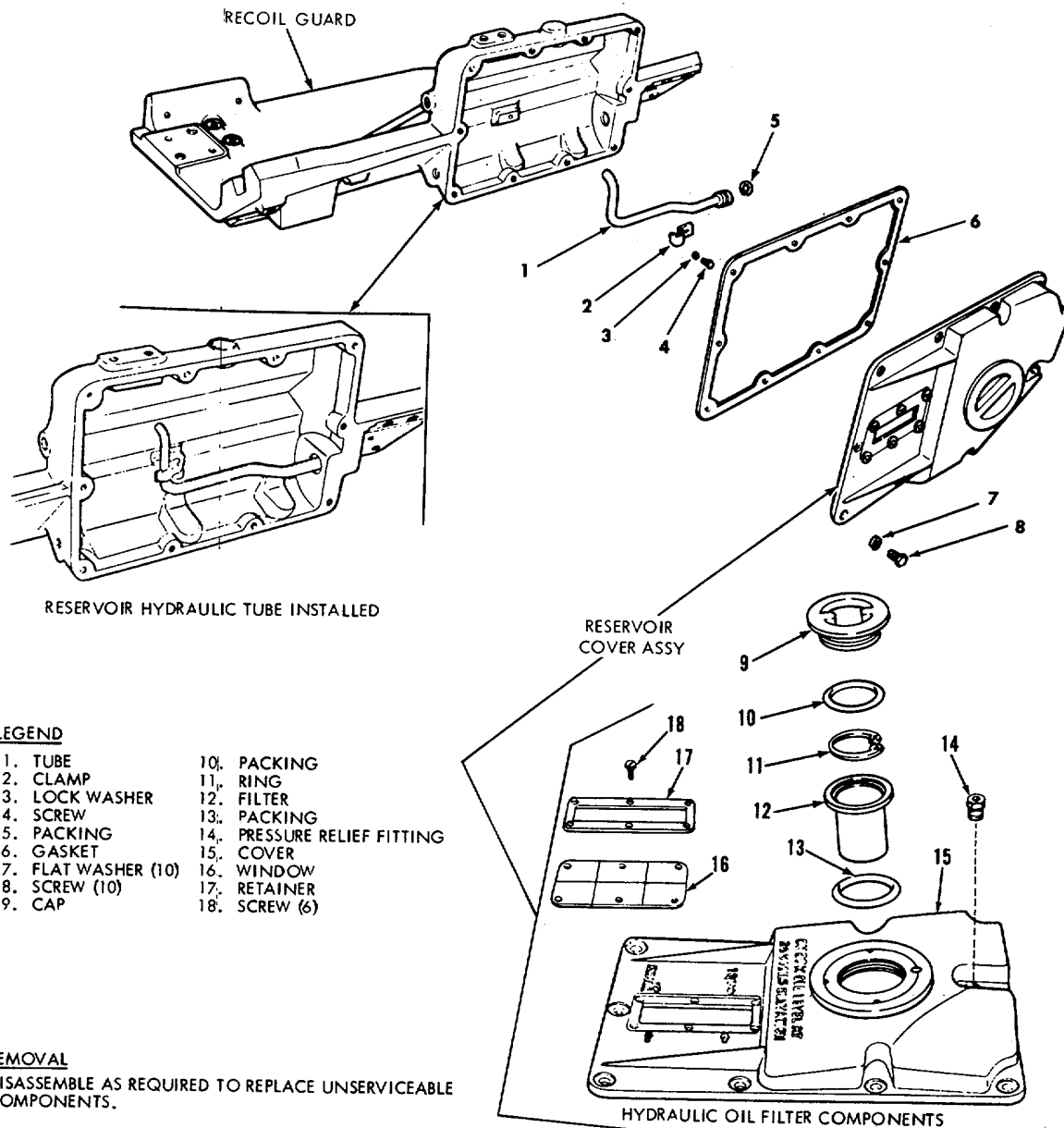

**LEGEND**

- |                     |                             |
|---------------------|-----------------------------|
| 1. TUBE             | 10. PACKING                 |
| 2. CLAMP            | 11. RING                    |
| 3. LOCK WASHER      | 12. FILTER                  |
| 4. SCREW            | 13. PACKING                 |
| 5. PACKING          | 14. PRESSURE RELIEF FITTING |
| 6. GASKET           | 15. COVER                   |
| 7. FLAT WASHER (10) | 16. WINDOW                  |
| 8. SCREW (10)       | 17. RETAINER                |
| 9. CAP              | 18. SCREW (6)               |

**REMOVAL**

DISASSEMBLE AS REQUIRED TO REPLACE UNSERVICEABLE COMPONENTS.

**NOTE:** INSPECT FILTER AND REPLACE IF TEARS OR HOLES ARE FOUND IN SCREEN. CLEAN WITH A REGULAR CLEANING SOLVENT (SOLVENT MUST BE CLEANED. DO NOT DRY SCREEN UNDER AIR PRESSURE. DAMAGE TO SCREEN MESH MAY RESULT.

**INSTALLATION**

REVERSE REMOVAL PROCEDURE.

ITEMS 6 AND 16: CLEAN MOUNTING SURFACES AND APPLY SEALING COMPOUND 8030-00-226-6436.

AR 910198

Figure 11-8. Removal/installation recoil mechanism reservoir components (2 of 2).

Figures 11-9 and 11-10--deleted.

**LEGEND**

1. SCREW (2)
2. PLUG LOCK
3. PLUG
4. PREFORMED PACKING
5. CHECK VALVE
6. PREFORMED PACKING
7. SEAL
8. SEAL

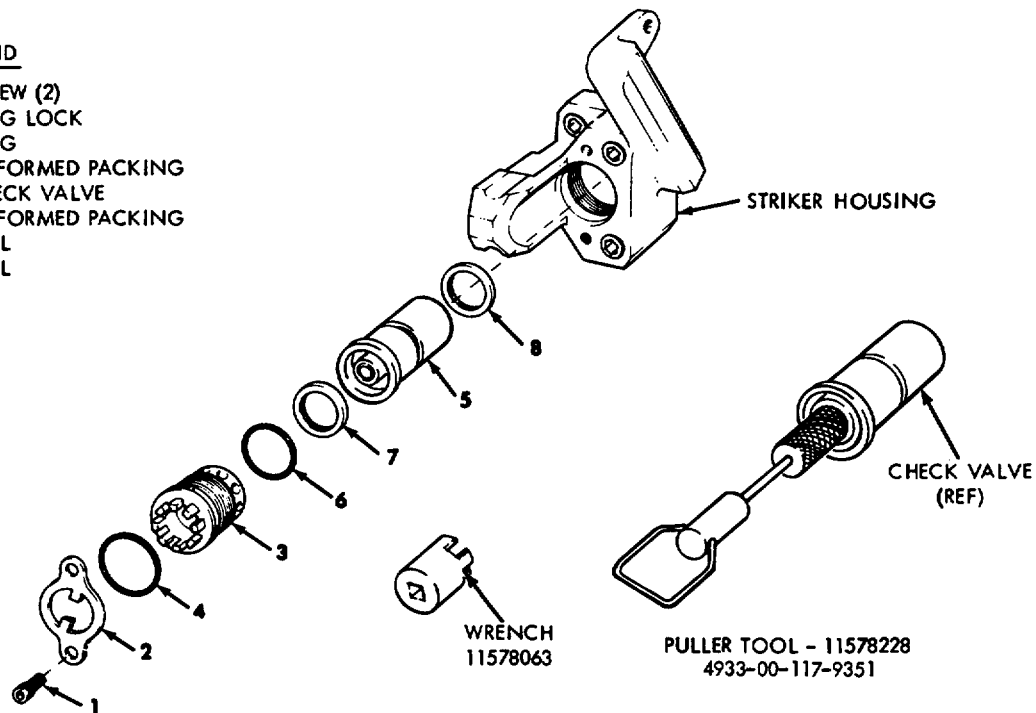
**PRELIMINARY STEP**

BLEED AIR PRESSURE FROM ENTIRE SYSTEM (FIG. 4-2) OR CLOSE MANUAL SHUT OFF VALVE IN LINE FROM CYLINDER AND BLEED PRESSURE FROM REST OF SYSTEM BY ACTUATING MANUAL DISCHARGE LEVER (FIG. 4-2).

**REMOVAL**

FOLLOW NUMERICAL SEQUENCE.

**NOTES:**

- A. USE WRENCH 11578063 TO REMOVE PLUG.
- B. REMOVE AND DISCARD PREFORMED PACKING FROM PLUG.
- C. USE PULLER TOOL 11578228 TO WITHDRAW CHECK VALVE ASSEMBLY FROM STRIKER HOUSING, EXERCISING CARE NOT TO SCRATCH OR DAMAGE SEALS.

**INSTALLATION**

1. INSTALL NEW PREFORMED PACKING ON BODY OF VALVE AND LUBRICATE WITH MIL-L-46150.
2. INSTALL SEALS IN VALVE IN SAME RELATIVE POSITIONS FROM WHICH THEY WERE REMOVED. (THE SEALING SURFACE NEXT TO THE GUN TUBE IS RECOGNIZABLE BY THE BURNISHED APPEARANCE ACQUIRED DURING FIRING).

3. INSTALL VALVE W/SEALS IN STRIKER HOUSING, WITH SHOULDER ON VALVE AWAY FROM GUN TUBE. A SMALL AMOUNT OF GIA LUBRICANT MAY BE USED TO HOLD THE SEALS IN PLACE DURING INSTALLATION.

4. INSTALL NEW PREFORMED PACKING ON PLUG AND LUBRICATE LIGHTLY WITH MIL-L-46150.
5. INSERT PLUG AND TIGHTEN TO 70-100 POUNDS- FEET TO SEAT SEALS. (USE WRENCH 11578063.)
6. OBSERVE POSITION OF ONE TANG OF THE PLUG, AND AND LOOSEN PLUG UNTIL THE ADJACENT TANG IS IN THIS POSITION (45° BACK-OFF).

**CAUTION: THIS 45° BACK-OFF IS REQUIRED TO ACCOMMODATE THE DIFFERENTIAL GROWTH OF GUN TUBE AND COUPLING DURING FIRING.**

7. DETERMINE CLOSEST POSITION OF PLUG LOCK, INVERTING AS NECESSARY, TO PERMIT LOCK AND SCREWS TO BE INSTALLED.

**CAUTION: PLUG MUST NOT BE TURNED MORE THAN 1/4 TANG EITHER DIRECTION FROM THE BACK-OFF POSITION AT END OF STEP 6.**

8. INSTALL PLUG LOCK AND SCREWS. TIGHTEN SCREWS TO 85-100 POUNDS-INCH (INCL PREVAILING TORQUE).

Figure 11-10.1. Removal/installation - breech scavenger check valve.

Pages 11-10.1 and 11-10.2--deleted.

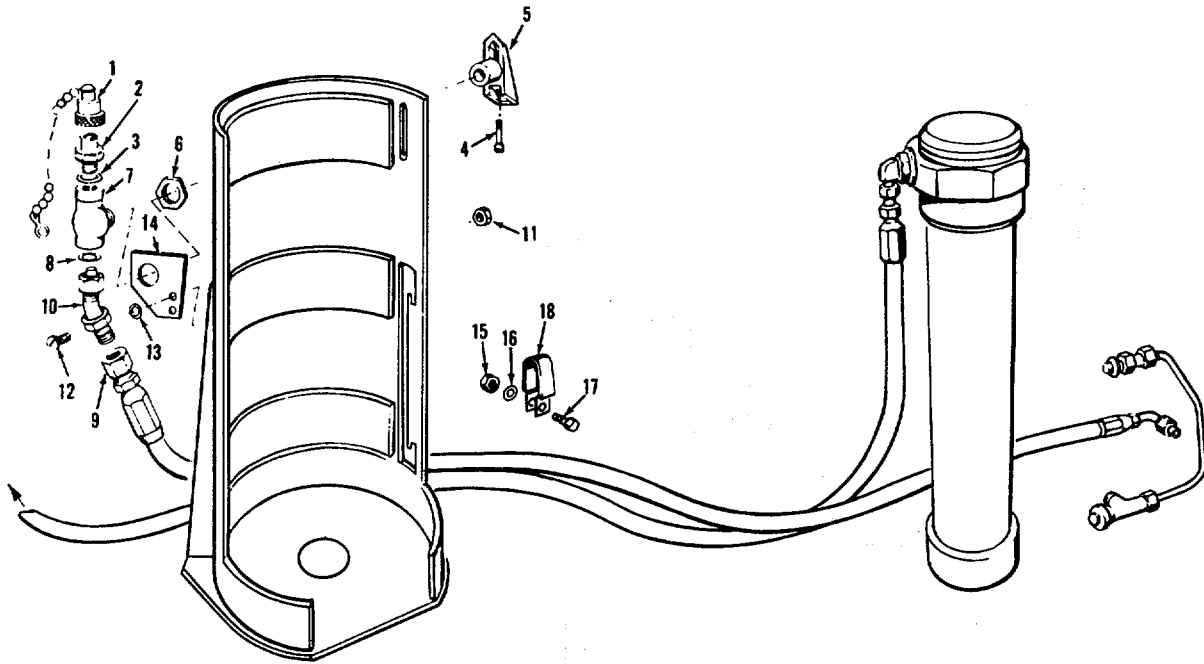

## LEGEND:

- |  |                                   |
|--|-----------------------------------|
| 1. CAP   |                                   |
| 2. COUPLING  |                                   |
| 3. PACKING   |                                   |
| 4. SETSCREW  | UNAUTHORIZED ITEMS;<br>PART OF #7 |
| 5. HANDLE  |                                   |
| 6. NUT   |                                   |
| 7. VALVE ASSEMBLY (BODY)   |                                   |
| 8. PACKING   |                                   |
| 9. NUT (HOSE-END) PART OF HOSE ASSEMBLY;<br>MUST LOOSEN TO REMOVE ELBOW (10) |                                   |
|  | 10. ELBOW                         |
|  | 11. NUT (2)                       |
|  | 12. SCREW (2)                     |
|  | 13. WASHER (2)                    |
|  | 14. PLATE                         |
|  | 15. NUT                           |
|  | 16. WASHER                        |
|  | 17. SCREW                         |
|  | 18. CLAMP                         |

**NOTE:** TO FACILITATE DISASSEMBLY, TRAVERSE TURRET UNTIL TURRET MISSILE STOWAGE RACK LOCATED JUST LEFT OF THE REAR AIR BOTTLE IS IN THE VICINITY OF THE DRIVER'S SEAT.

**WARNING:** PRIOR TO DISCONNECTING ANY SECTION OF CBSS, TURN MASTER AND COMPRESSOR SWITCHES OFF AND BLEED ALL AIR IN SYSTEM. SEE FIGURE 4-2.

**INSTALLATION NOTE:** ALL COMPONENTS MUST BE ASSEMBLED PRIOR TO TIGHTENING. TORQUE ITEM 2, NUTS ON ITEMS 9 AND 10, TO 100-150 IN-LB.

WE 73809

Figure 11-10.1.1. Removal/installation of CBSS slaving system.

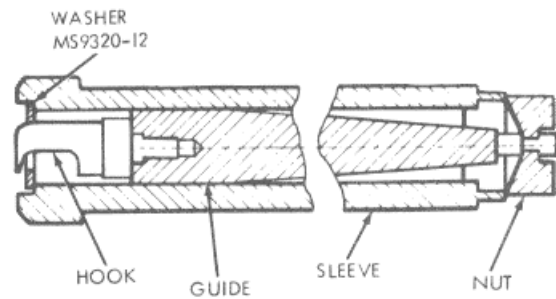
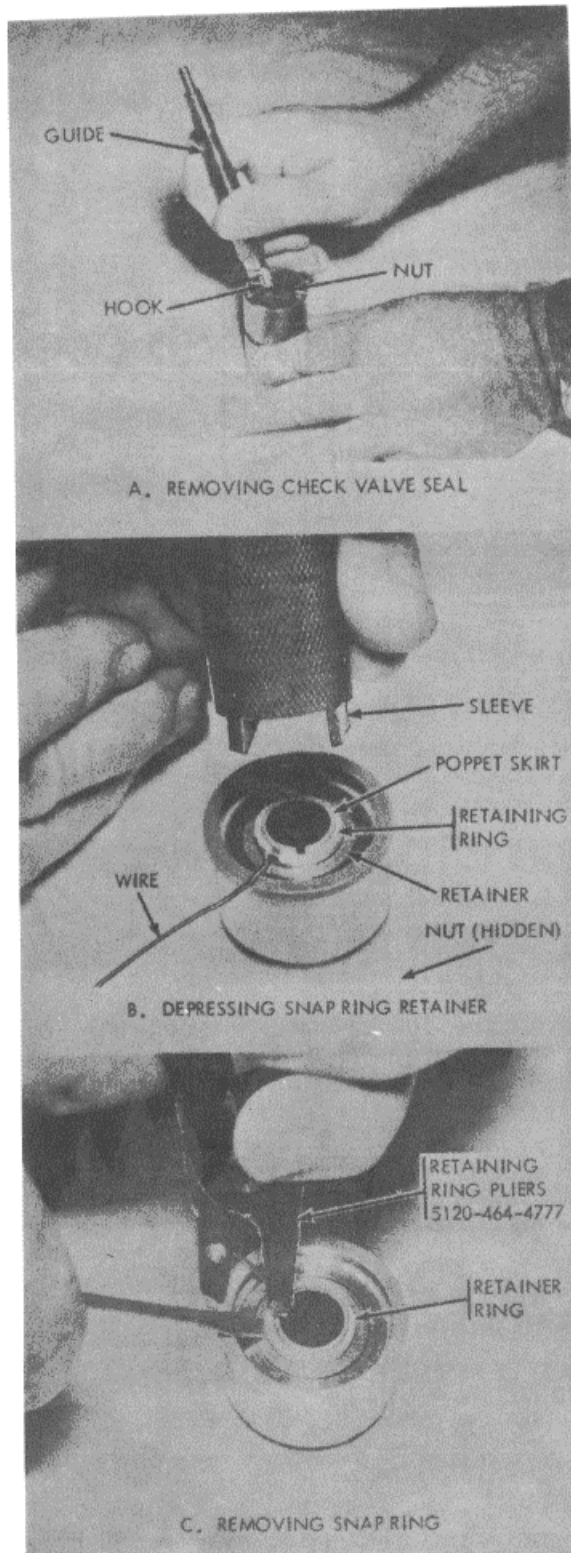

D. CHECK VALVE SERVICING TOOL ASSEMBLY  
4933-464-4776.

REFER TO TABLE 8-17.1 FOR SERVICING  
INTERVAL.

DISASSEMBLY

1. REMOVE AND DISCARD PREFORMED PACKING FROM BODY OF CHECK VALVE.
  2. REMOVE SEALS FROM EACH END OF CHECK VALVE, USING HOOK, GUIDE AND NUT AS SHOWN IN VIEW A. PRY SEAL GENTLY, WORKING INSIDE THE FULL CIRCUMFERENCE IN UNDERCUT OF SEAL.
- CAUTION:** DO NOT SCRATCH SEAL OR SEATING SURFACE.
3. REMOVE POPPET RETAINING RING AS FOLLOWS:
    - A. INVERT CHECK VALVE OVER NUT TO HOLD POPPET SEATED.
    - B. ROTATE RETAINING RING UNTIL OPENING IS APPROXIMATELY 45° FROM SLOT IN POPPET SKIRT (VIEW B).
    - C. DEPRESS RETAINER WITH TOOL SLEEVE AND INSERT A SMALL DIAMETER WIRE UNDER RETAINING RING TO HOLD RETAINER DEPRESSED (VIEW B).
    - D. USE RETAINING RING PLIERS TO RELEASE RETAINING RING FROM ITS GROOVE. USE A THIN BLADED SCREW DRIVER TO PRY RING UP OFF POPPET SKIRT (VIEW C). HOLD HAND OVER RETAINING RING DURING REMOVAL TO AVOID LOSING PARTS WHEN SPRING IS RELEASED.
  4. REMOVE RETAINER, SPRING AND POPPET FROM VALVE BODY.

WE 12116 ■

Figure 11-10.2. Disassembly/cleaning/assembly - breech scavenger check valve (1 of 2).

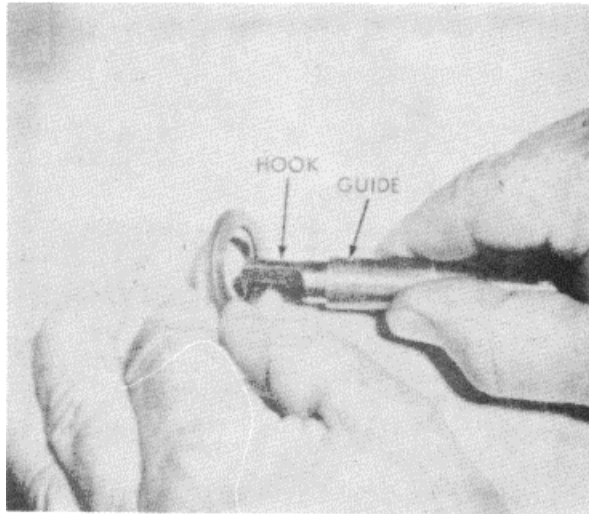

D. CLEANING SEAL UNDERCUT

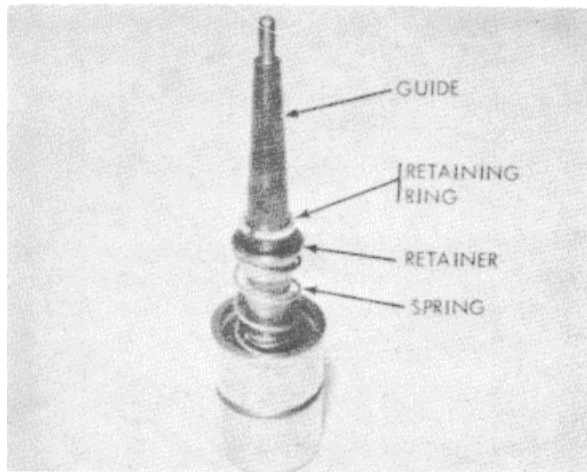

E. INSTALLING TOOL AS GUIDE

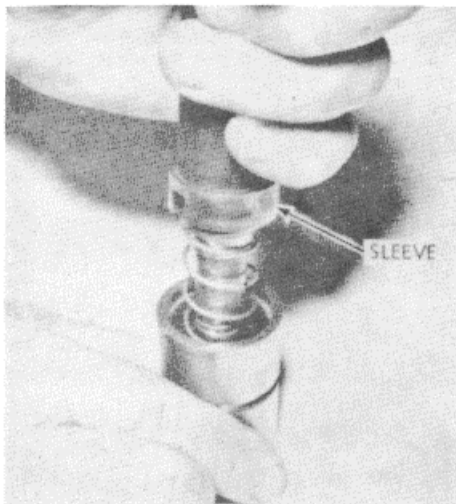

F. FORCING COMPONENTS INTO VALVE

CLEANING AND INSPECTION

1. CLEAN ALL SURFACES USING HOT WATER AND SOAP OR OTHER CARBON SOLVENT.
2. VISUALLY INSPECT FOR NICKS, SCRATCHES, DEFORMATION OR CRACKS.

**NOTE.** SPECIAL ATTENTION SHOULD BE GIVEN TO POPPET VALVE AND SEAT AND TO VALVE SEAL SURFACES. SCRATCHES OR DENTS IN THESE SURFACES REQUIRE REPLACEMENT OF VALVE ASSEMBLY.

3. USE HOOK TO REMOVE CARBON FROM SEAL UNDERCUT SURFACES, EXERCISING CARE TO AVOID SCRATCHING OR DEFORMING SEALING SURFACES (VIEW D).
4. INSPECT SEAL SURFACES FOR NICKS, DEFORMITY OR SCRATCHES. CHECK SEAL UNDERCUT FOR CRACKS. REPLACE DEFECTIVE SEALS AS REQUIRED.

ASSEMBLY

1. ASSEMBLE POPPET IN VALVE BODY BORE AND CHECK FOR COMPLETE FREEDOM OF SLIDING SURFACES. DO NOT LUBRICATE.

**CAUTION:** MAKE SURE HEAD OF POPPET IS IN END OF VALVE OPPOSITE FROM SHOULDER ON OUTSIDE OF VALVE BODY.

2. WITH POPPET IN BODY, INVERT VALVE BODY OVER NUT TO HOLD POPPET SEATED.
3. INSERT HOOK AND GUIDE INTO POPPET SLEEVE AS A GUIDE FOR SPRING, RETAINER AND RETAINING RING IN THAT ORDER (VIEW E).
4. PLACE SLEEVE OF TOOL OVER GUIDE AND SLOWLY DEPRESS THE COMPONENTS UNTIL RETAINING RING ENGAGES ITS MATING GROOVE (VIEW F).
5. ASSEMBLE CHECK VALVE TOOL ASSEMBLY FOR STOWAGE (FIG. 11-10.2).
6. INSTALL CHECK VALVE ASSEMBLY IN STRIKER HOUSING (FIG. 11-10.1).

WE 12104

Figure 11-10.3. Disassembly/cleaning/assembly - breech scavenger check valve (2 of 2)



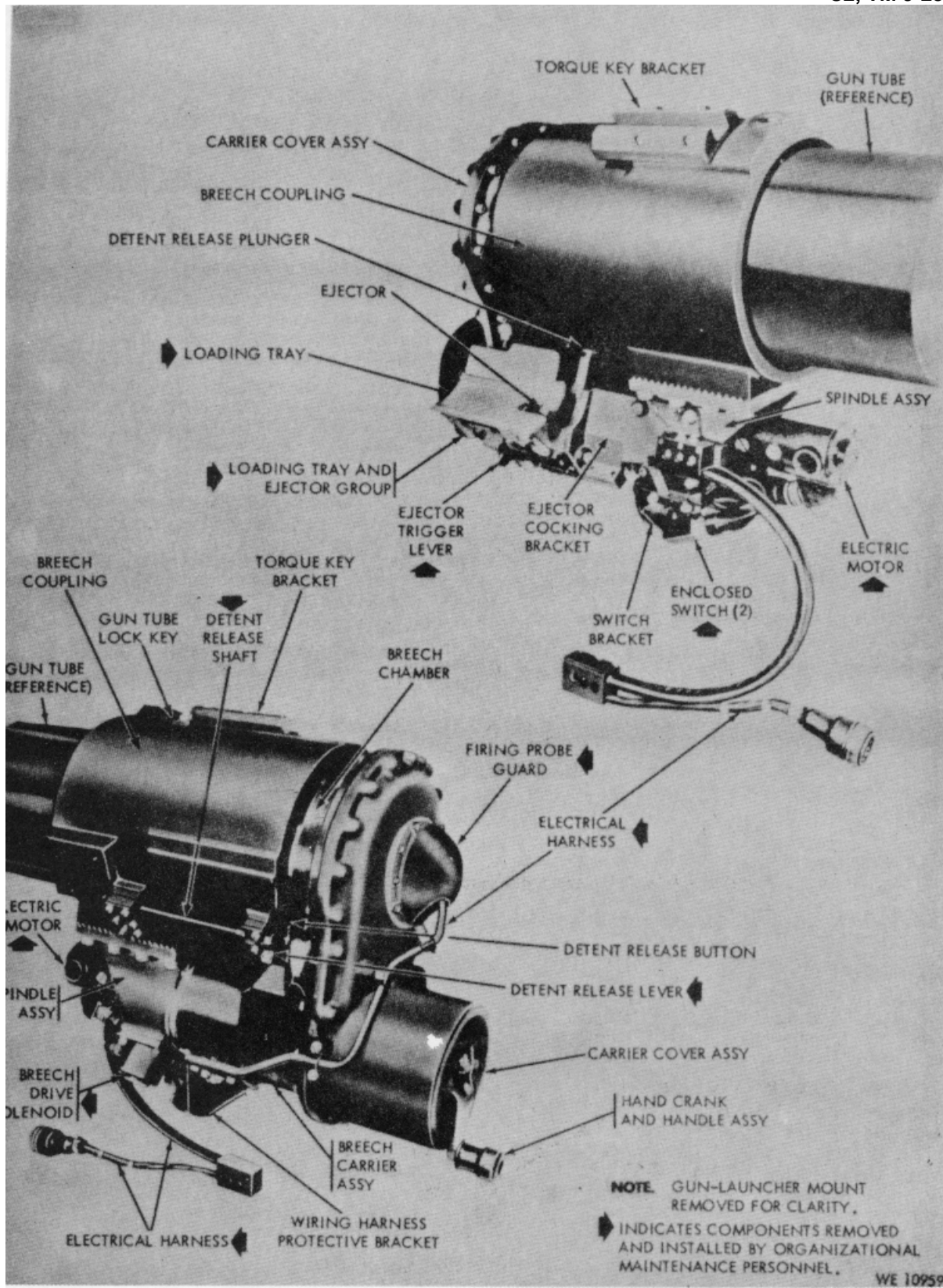
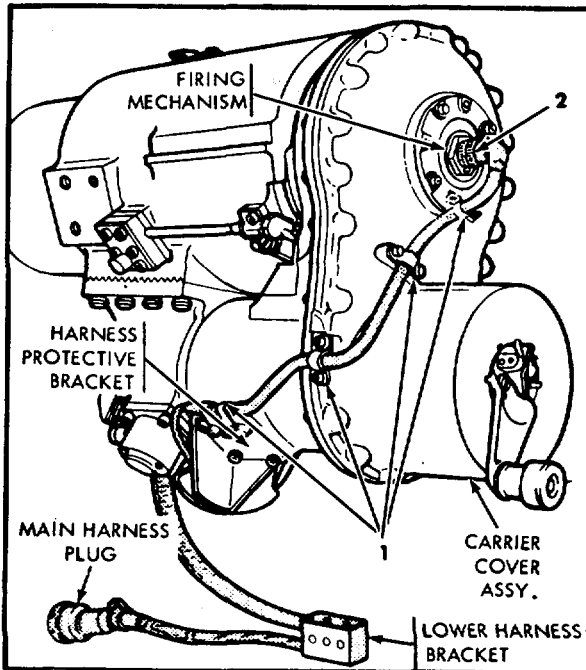

Figure 11-11. M81 gun-launcher breech assembly and components - reference



PRELIMINARY STEP: REMOVE FIRING MECHANISM HARNESS GUARD, FIG. 11-13.

**REMOVAL**

1. REMOVE 8 SCREWS, WASHERS, AND 4 ELECTRICAL HARNESS CLAMPS.
2. UNSCREW HARNESS PLUG FROM FIRING MECHANISM.
3. UNSCREW HARNESS PLUGS FROM SOLENOID, ELECTRIC MOTOR, AND ENCLOSED SWITCHES.

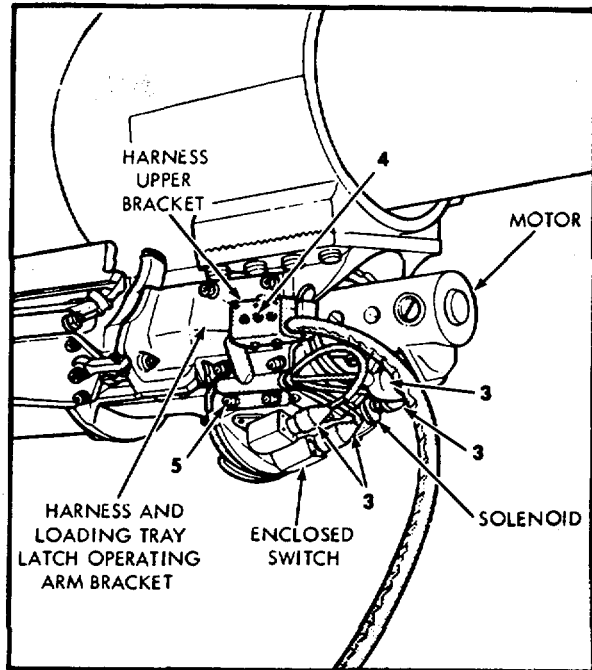

4. REMOVE 3 SCREWS AND WASHERS ATTACHING HARNESS UPPER BRACKET TO HARNESS AND LOADING TRAY LATCH OPERATING ARM BRACKET.
5. REMOVE 2 SCREWS AND WASHERS ATTACHING ELECTRICAL HARNESS TO SWITCH BRACKET AND REMOVE ELECTRICAL HARNESS.

**INSTALLATION NOTE**

TIGHTEN SCREWS (ITEMS 6,5,4, AND 1) TO 85-100 POUNDS-INCH (INCL PREVAILING TORQUE).

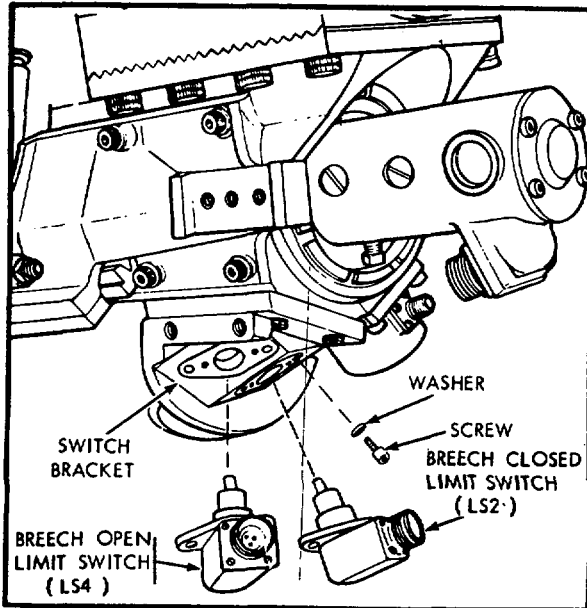

6. REMOVE 4 SCREWS, WASHERS, AND 2 BREECH LIMIT SWITCHES.

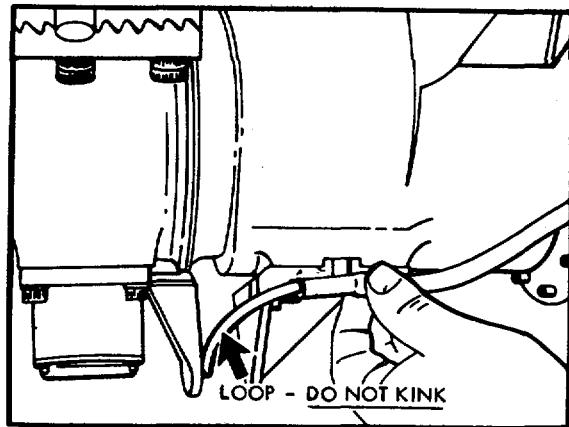

**INSTALLATION**

REVERSE REMOVAL PROCEDURE.

**CAUTION:** MAKE SURE HARNESS IS NOT TWISTED WHEN INSTALLING LOOP BETWEEN SWITCH BRACKET AND HARNESS BRACKET (SEE PANEL ABOVE).

WE 70030

Figure 11-12. Removal/installation - gun-launcher electrical wiring harness and brech limit switches

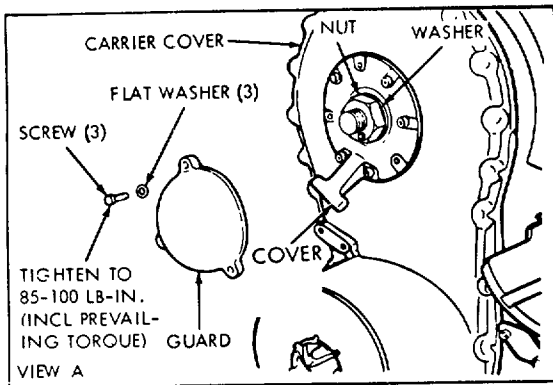

1. OPEN BREECH, REMOVE GUARD, 2 UPPER HARNESS CLAMPS AND DISCONNECT HARNESS. SEE FIG. 11-12. (USE PLIERS 5120-00-624-8065).

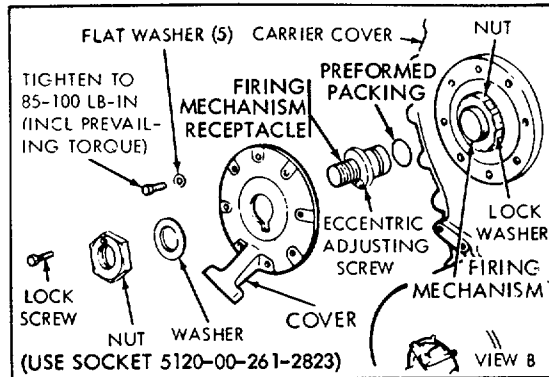

2. LOOSEN LOCK SCREW AND REMOVE OUTER NUT AND WASHER. AT INSTALLATION, ADJUST CONTINUITY AND TIGHTEN NUT TO 100-125 LB-FT.
  3. REMOVE 5 SCREWS, WASHERS, AND COVER.
  4. REMOVE FIRING MECHANISM RECEPTACLE AND PREFORMED PACKING.
- INSTALLATION NOTE: USE CARE WHEN INSTALLING RECEPTACLE TO PREVENT DAMAGE TO ELECTRICAL CONTACTS.

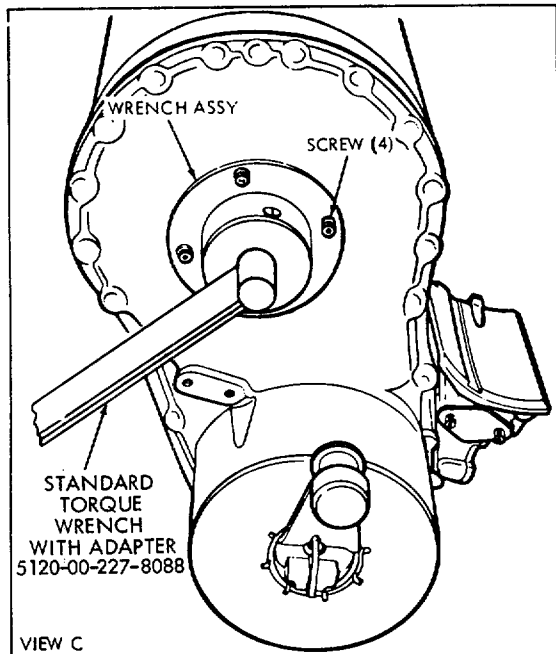

5. STRAIGHTEN TAB ON LOCK WASHER. (VIEW D)
6. INSTALL WRENCH ASSY - 4933-00-915-8560 USING 4 OF THE 5 SCREWS REMOVED FROM COVER (STEP 3). LOOSEN NUT AND REMOVE WRENCH ASSY.

**REMOVAL**

REMOVE FIRING MECHANISM BY FOLLOWING NUMERICAL SEQUENCE. CLEAN CONTACT WITH ROUGH CLOTH OR STEEL WOOL 5350-00-242-4404.

**INSTALLATION**

REVERSE REMOVAL PROCEDURE. REPLACE PREFORMED PACKING (5330-00-080-9075) (STEP 4). ADJUST RECEPTACLE FOR CONTINUITY (FIG 11-1.4).

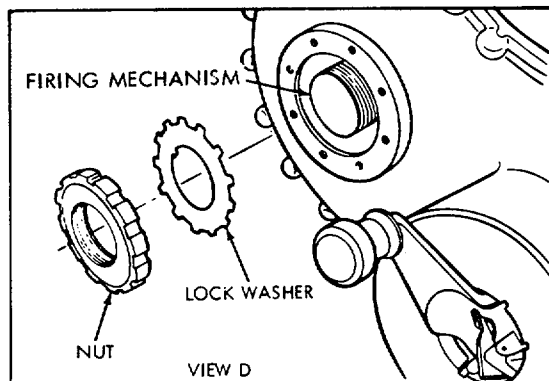

7. UNSCREW NUT AND REMOVE LOCK WASHER FROM FIRING MECHANISM.

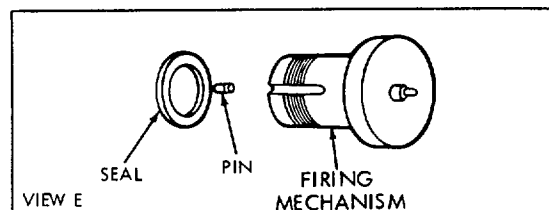

8. REMOVE FIRING MECHANISM, PIN, AND SEAL FROM BREECH CHAMBER. INSERT A PIECE OF PAPER THROUGH THE REAR OF THE CASE AND HOLD UNDER THE FIRING MECHANISM TO CATCH THE PIN SHOULD IT BE DROPPED.

**NOTE**

AT INSTALLATION TIGHTEN NUT 200 TO 250 LB-FT. AT INTERVALS OF EVERY 200 CONVENTIONAL ROUNDS FIRED, REMOVE, CLEAN, AND INSPECT SEAL (VIEW E) AND SEAL SEATING SURFACES INSIDE THE BREECH CHAMBER. IF PITTING OR EROSION IS FOUND, REPLACE PARTS.

AR 900675

Figure 11-13. Removal/installation - gun-launcher firing mechanism assembly.

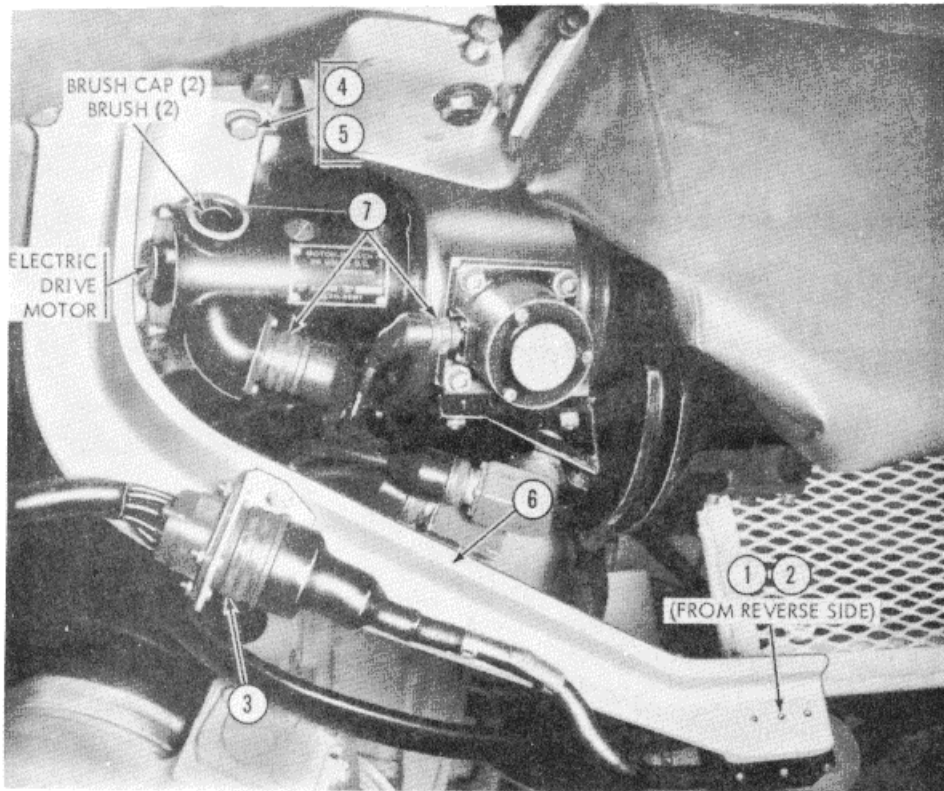

LEGEND

- |   |  |
|---|--|
| 1. SCREW (3)  | 6. HARNESS BRACKET   |
| 2. WASHER (3)   | 7. ELECTRICAL CONNECTORS (2)<br>(USE PLIERS 5120-624-8065) |
| 3. ELECTRICAL CONNECTOR<br>(USE PLIERS 5120-624-8065) | 8. SPANNER NUT   |
| 4. SCREW (3)  | 9. MOTOR   |
| 5. WASHER (3)   |  |

PRELIMINARY STEP

ELEVATE GUN-LAUNCHER TO MAXIMUM AND TRAVERSE TURRET FOR BEST ACCESSIBILITY FROM DRIVER'S COMPARTMENT.

REMOVAL

FOLLOW NUMERICAL SEQUENCE. USE WRENCH 5120-915-8572 WITH 1/2" DRIVE SOCKET WRENCH HANDLE AS EXTENSION TO REMOVE SPANNER NUT (8).

INSTALLATION

ALIGN MOTOR WITH ANTI-ROTATION PIN IN SPINDLE ASSEMBLY, AND REVERSE REMOVAL PROCEDURE. USE WRENCH 5120-915-8572 WITH TORQUE WRENCH 5120-640-6364 TO TORQUE SPANNER NUT TO 175 POUNDS-FOOT DIAL READING (ACTUAL APPLIED TORQUE WILL BE 227.5 POUNDS-FOOT).

NOTE. BRUSHES MAY BE REPLACED OR INSPECTED WITHOUT REMOVING MOTOR.

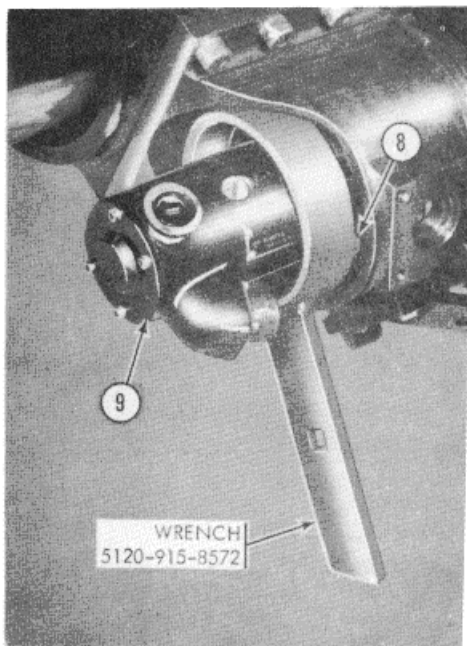

WE 12105

Figure 11-14. Removal/installation - breech electric drive motor assembly

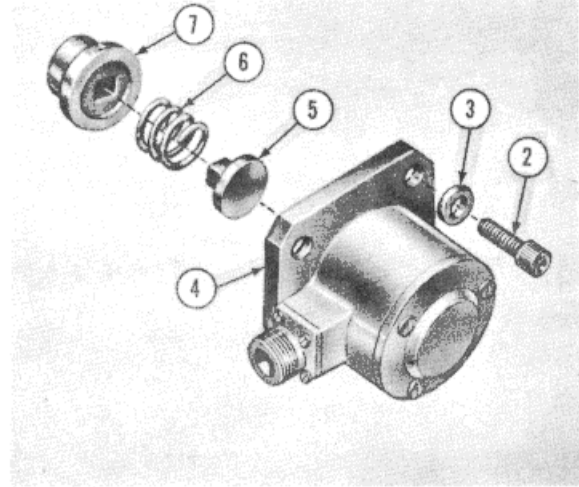
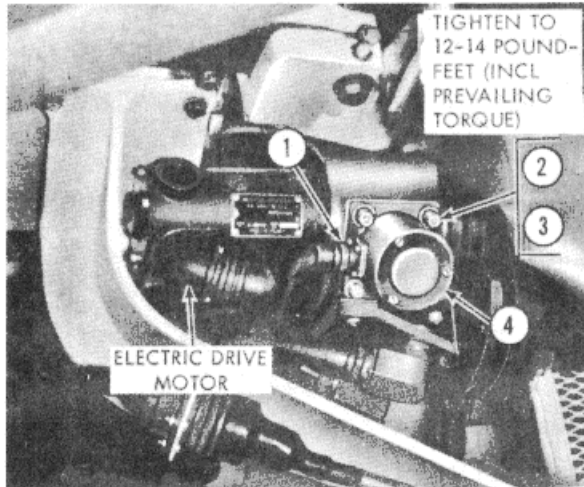

REMOVAL  
FOLLOW NUMERICAL SEQUENCE.  
INSTALLATION  
REVERSE REMOVAL SEQUENCE.

- LEGEND
1. ELECTRICAL CONNECTOR
  2. SCREW (4)
  3. FLAT WASHER (4)
  4. BREECH DRIVE SOLENOID
  5. RING GEAR LOCKING PLUNGER
  6. PLUNGER SPRING
  7. PLUNGER SUPPORT BUSHING

WE 66555

Figure 11-15. Removal/installation - breech electric drive solenoid

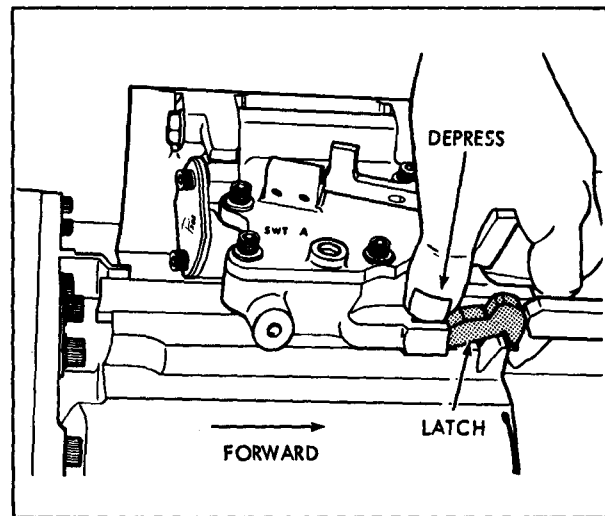
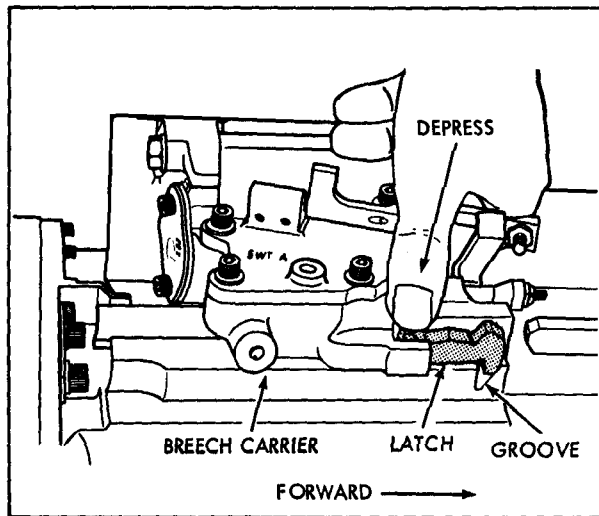

PRELIMINARY STEP

OPEN BREECH UNTIL SWING OVER CYCLE BEGINS. THIS WILL ALLOW DETENT RELEASE PLUNGER TO CLEAR COUPLING DURING REMOVAL.

1. DEPRESS LOADING TRAY AND EJECTOR GROUP LATCH TO RELEASE LATCH FROM GROOVE IN BREECH CARRIER.
2. WITH LATCH DEPRESSED, SLIDE LOADING TRAY AND EJECTOR GROUP FORWARD ON BREECH CARRIER GUIDE AND THEN LIFT FROM BREECH CARRIER.

WE 11136

Figure 11-16. Removal/installation - loading tray bracket assembly

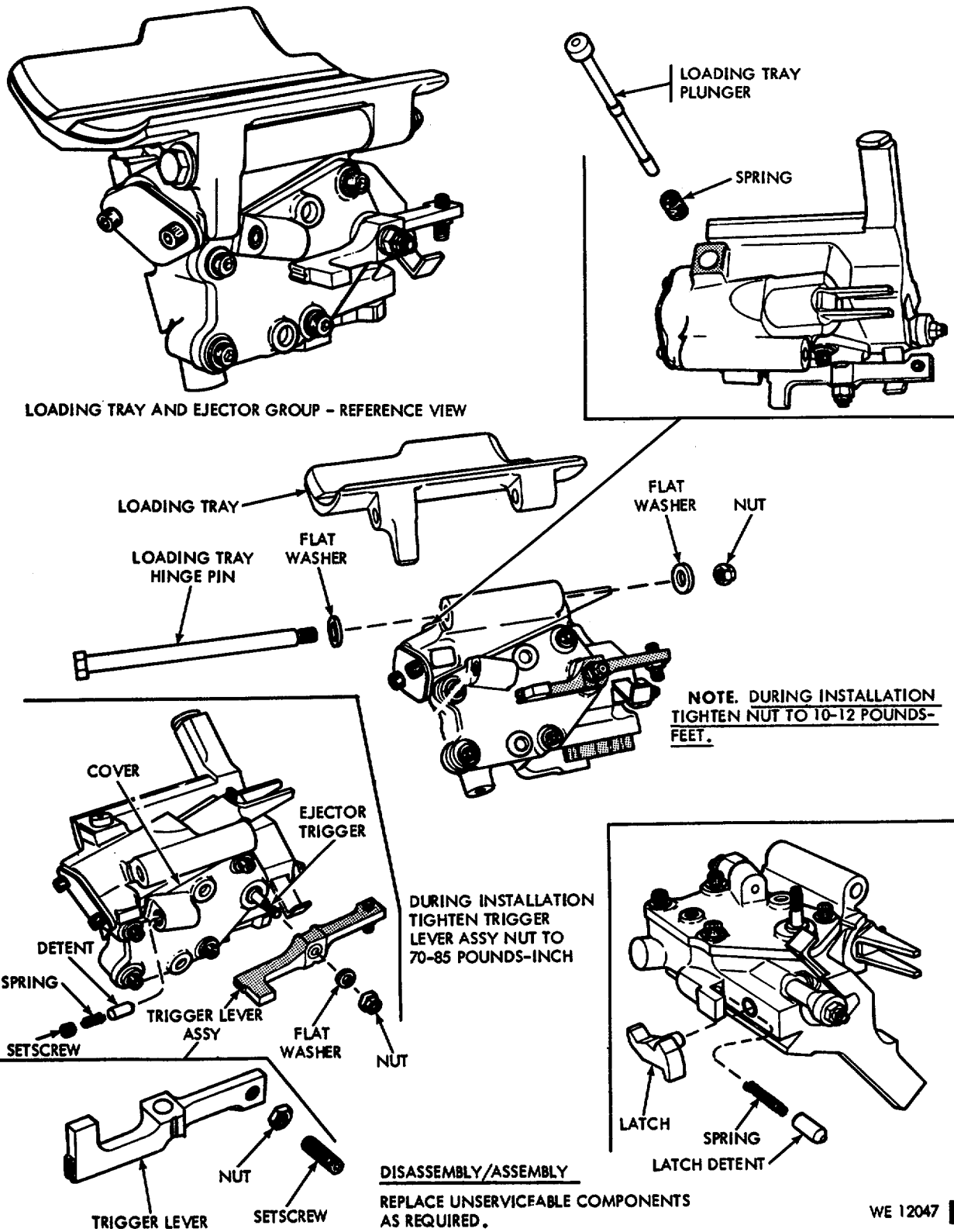

Figure 11-17. Disassembly/assembly - loading tray bracket assembly (1 of 3)

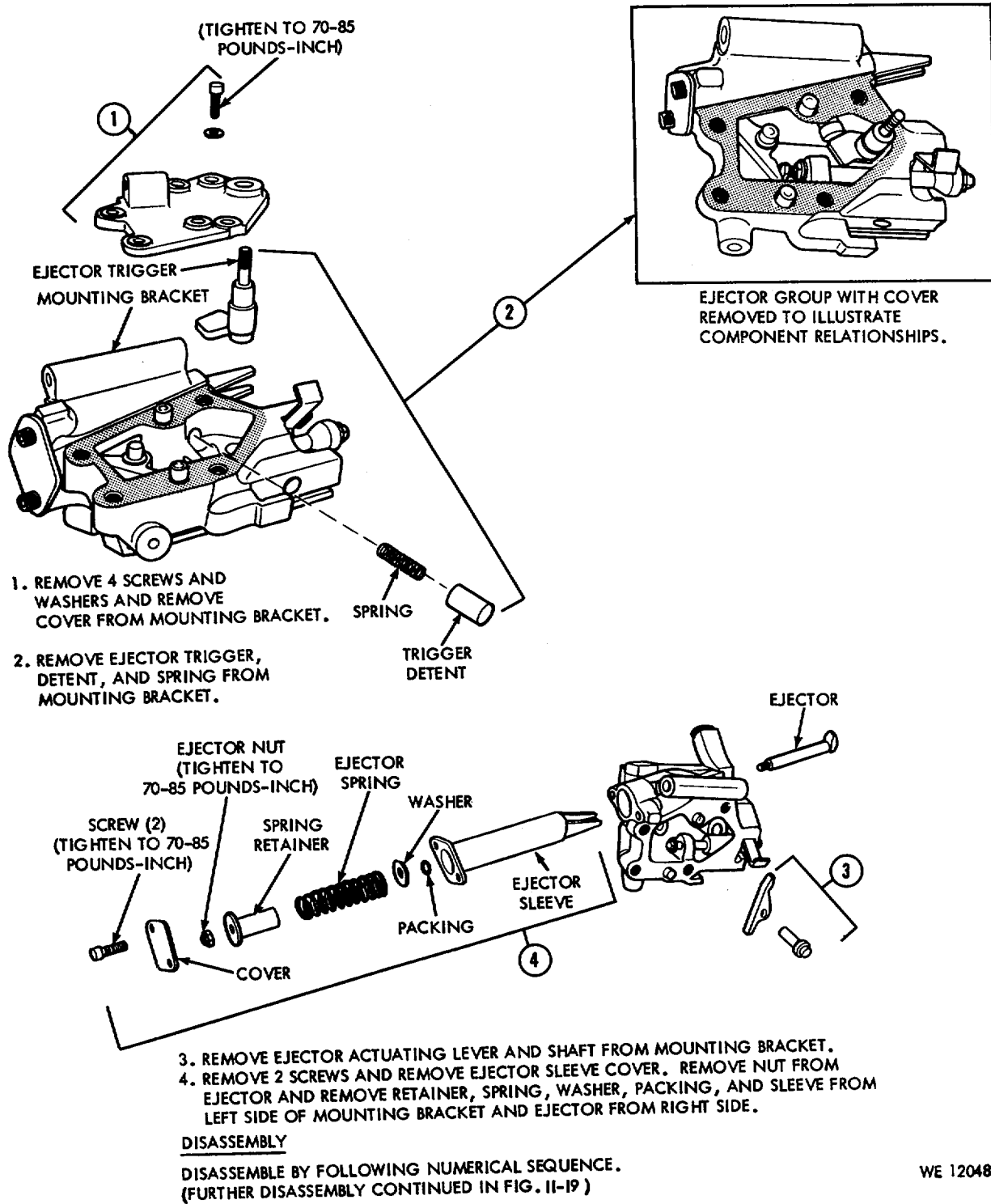
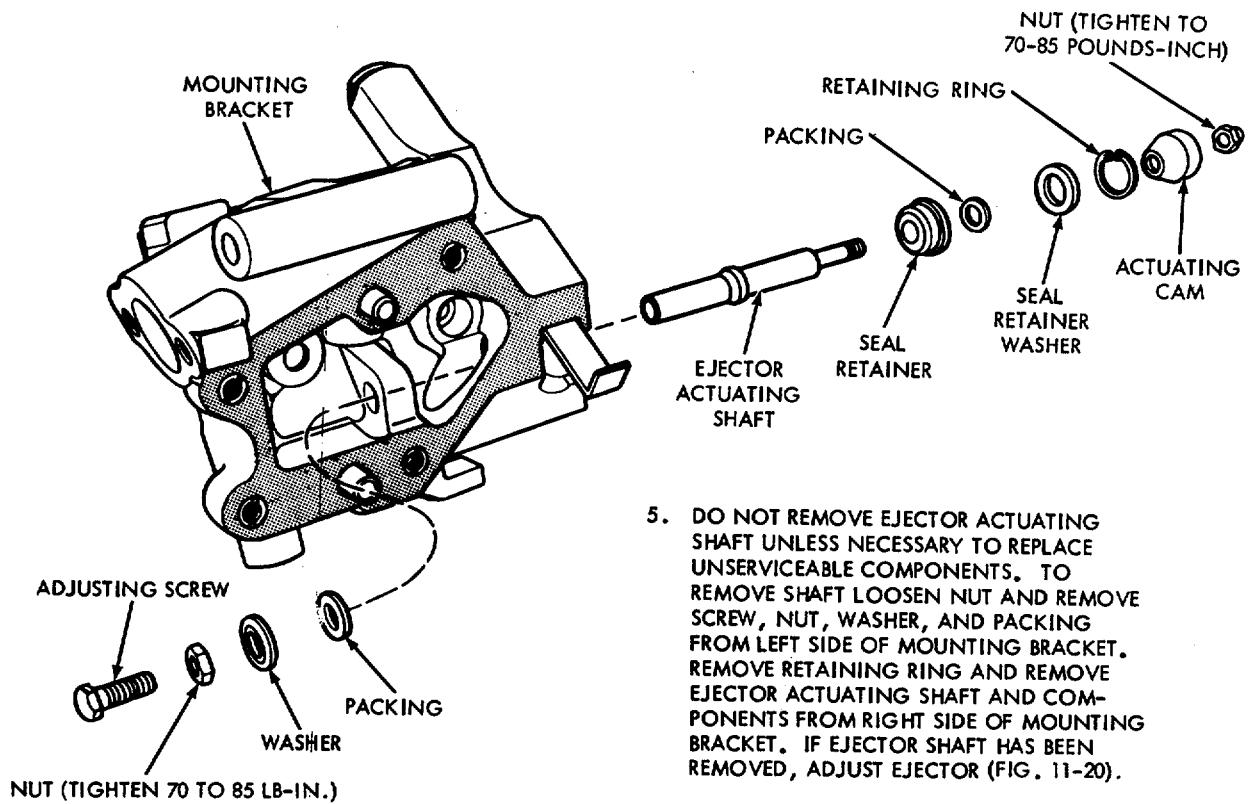
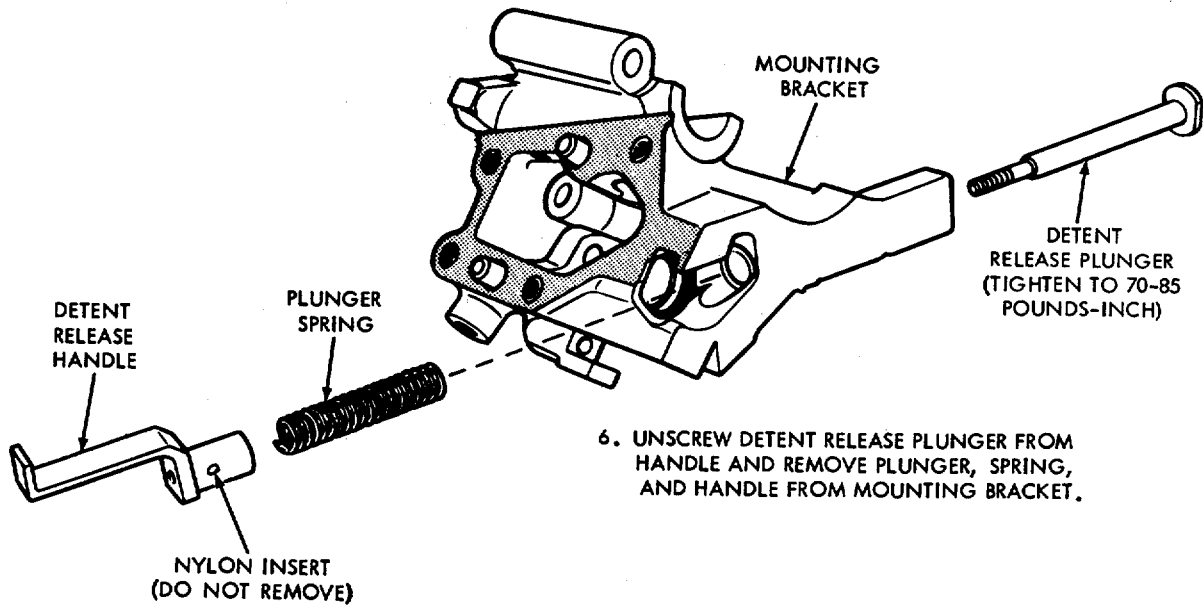

Figure 11-18. Disassembly/assembly - loading tray bracket assembly (2 of 3)



5. DO NOT REMOVE EJECTOR ACTUATING SHAFT UNLESS NECESSARY TO REPLACE UNSERVICEABLE COMPONENTS. TO REMOVE SHAFT LOOSEN NUT AND REMOVE SCREW, NUT, WASHER, AND PACKING FROM LEFT SIDE OF MOUNTING BRACKET. REMOVE RETAINING RING AND REMOVE EJECTOR ACTUATING SHAFT AND COMPONENTS FROM RIGHT SIDE OF MOUNTING BRACKET. IF EJECTOR SHAFT HAS BEEN REMOVED, ADJUST EJECTOR (FIG. 11-20).



6. UNSCREW DETENT RELEASE PLUNGER FROM HANDLE AND REMOVE PLUNGER, SPRING, AND HANDLE FROM MOUNTING BRACKET.

**ASSEMBLY** ADJUST LOADING TRAY AND EJECTOR (FIG. 11-20)

REVERSE DISASSEMBLY PROCEDURE (FURTHER ASSEMBLY CONTINUED IN FIG. 11-17 AND 11-18.

AR 910700

Figure 11-19. Disassembly/assembly - loading tray bracket assembly (3 of 3).



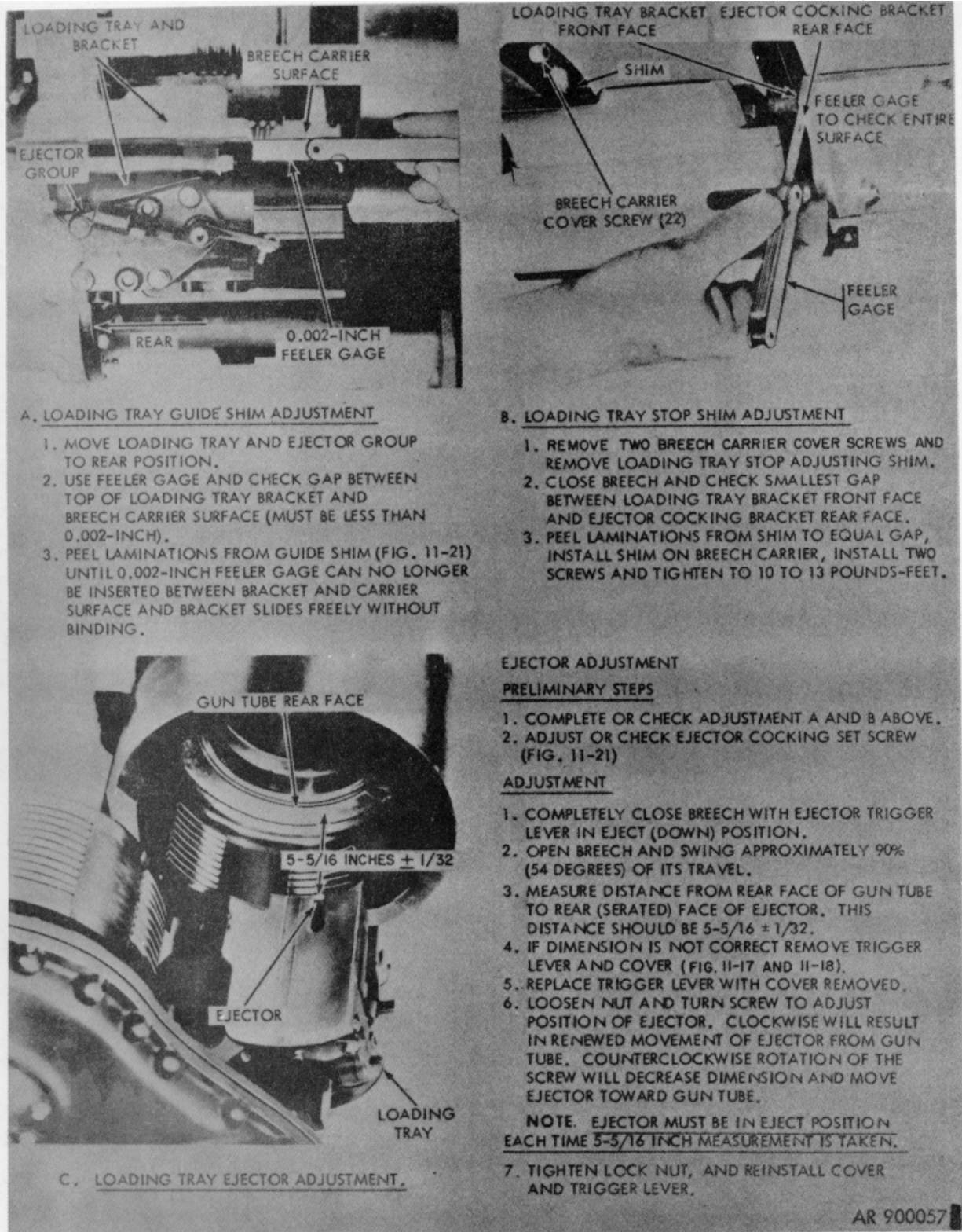
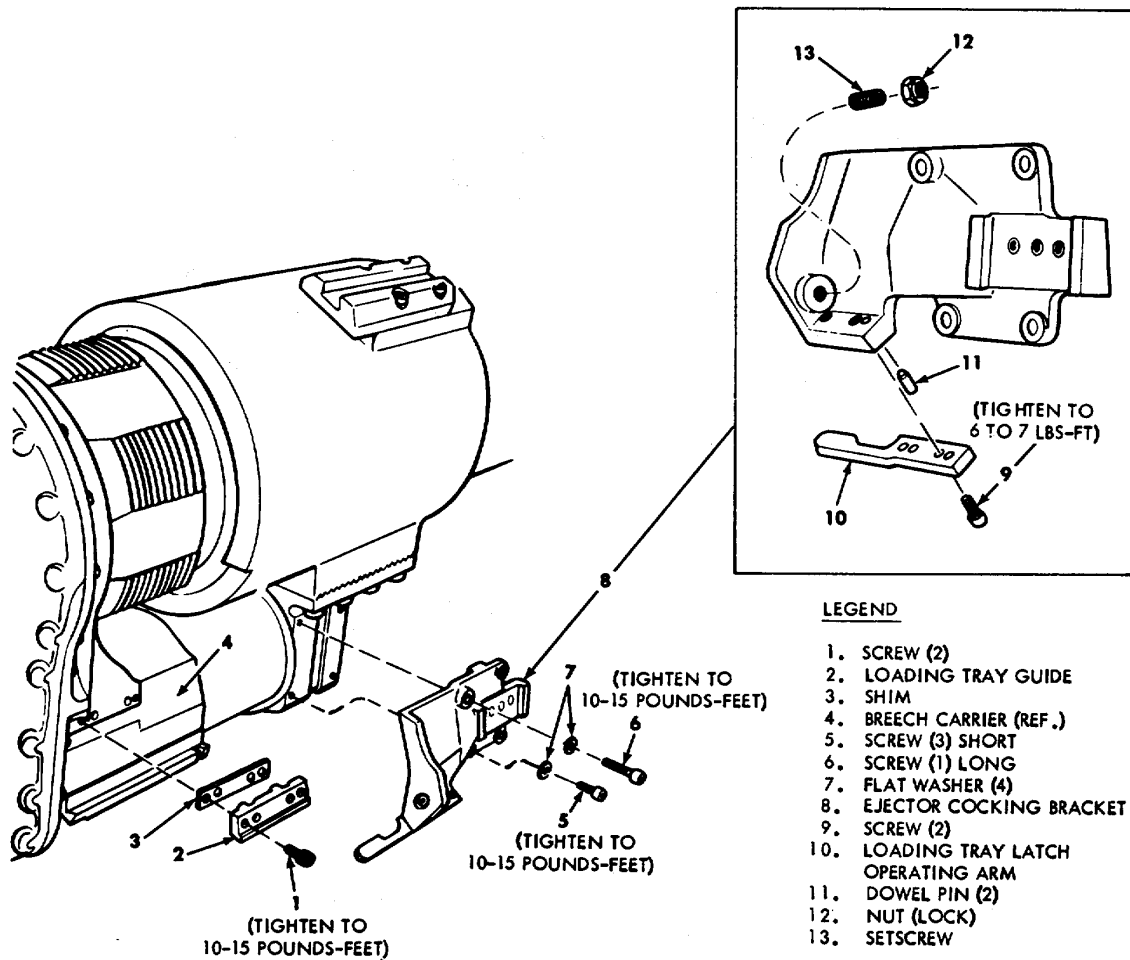

Figure 11-20. Adjustment - loading tray and ejector.

**PRELIMINARY STEPS**

1. DISCONNECT ELECTRICAL CONNECTOR AND REMOVE WIRING HARNESS (FIGURE 11-12).
2. REMOVE LOADING TRAY AND EJECTOR GROUP COMPLETE (FIGURE 11-16).

**REMOVAL**

REPLACE UNSERVICEABLE COMPONENTS AS REQUIRED.

**INSTALLATION**

1. REVERSE REMOVAL PROCEDURE.
2. REFER TO FIGURE 11-20 FOR ADJUSTMENT OF LOADING TRAY GUIDE SHIM AND TRAY STOP SHIM.
3. ADJUSTMENT OF EJECTOR COCKING BRACKET SETSCREW (ITEM 13).
  - A. BACK OUT SETSCREW FLUSH WITH THREADED INSERT.
  - B. COMPLETELY CLOSE BREECH.
  - C. WITH THE TRIGGER LEVER IN THE EJECT (DOWN) POSITION TIGHTEN THE SETSCREW UNTIL THE LEVER IS OBSERVED TO RISE AND THEN FALL DOWN INTO THE COCKED LATCH POSITION. TIGHTEN SETSCREW AN ADDITIONAL 1/4 TURN THEN TIGHTEN LOCK NUT (ITEM 12) TO SECURE THE SETSCREW.
  - D. CHECK OPERATION BY PARTLY OPENING THE BREECH WITH THE TRIGGER LEVER IN THE EJECT (DOWN) POSITION. THE EJECTOR SHOULD REMAIN EXTENDED IF PROPERLY ADJUSTED.

WE 66659

Figure 11-21. Removal/installation - loading tray guide and ejector cocking bracket

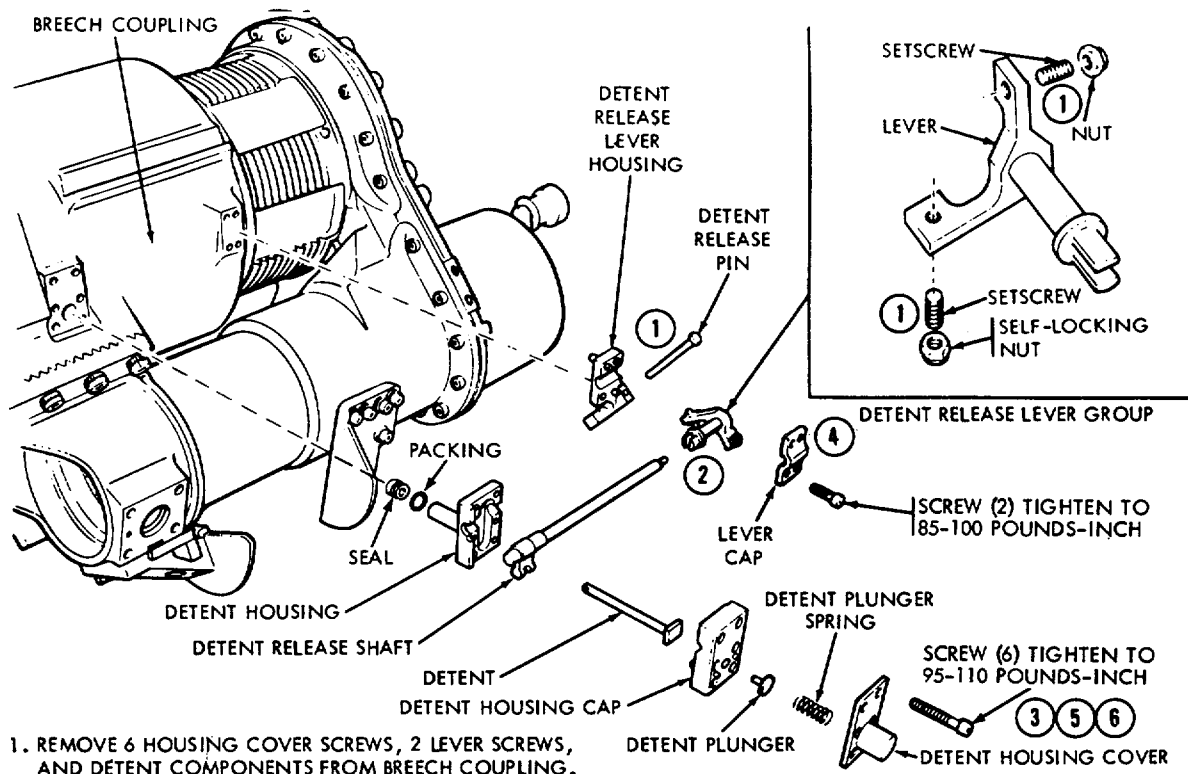

1. REMOVE 6 HOUSING COVER SCREWS, 2 LEVER SCREWS, AND DETENT COMPONENTS FROM BREECH COUPLING.

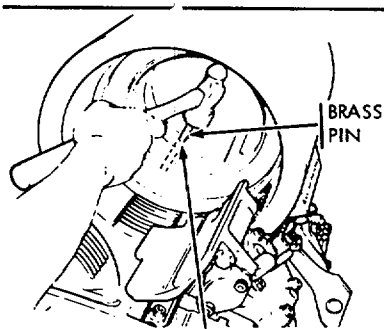

2. OPEN BREECH AND USE 3/8 BRASS PIN TO DRIVE DETENT SEAL ASSY FROM BREECH COUPLING.

**NOTE.** NEW PACKING MUST BE INSTALLED EACH TIME DETENT IS SERVICED. IF SEAL SHOWS EVIDENCE OF GAS-WASH, REPLACE SEAL. PRESS SEAL AND PACKING INTO BREECH COUPLING WITH DETENT AND DETENT HOUSING.

**REMOVAL**

REMOVE COMPONENTS AS SHOWN IN STEPS 1 AND 2. CLEAN AND INSPECT (FIG. 11-23).

**INSTALLATION** (CIRCLED NUMBERS REFER TO INSTALLATION STEPS)

1. LOOSELY INSTALL SETSCREW AND LOCK NUT IN DETENT RELEASE LEVER SHORT ARM AND SETSCREW WITH SELF-LOCKING NUT IN LONG ARM. INSTALL DETENT RELEASE PIN IN DETENT RELEASE LEVER HOUSING.
2. ASSEMBLE DETENT INTO HOUSING AND SLIP SEAL WITH NEW PACKING OVER DETENT, WITH PACKING GROOVE CLOSEST TO HOUSING. LIGHTLY APPLY LUBRICANT MIL-L-46150 TO SEAL.
3. ASSEMBLE DETENT RELEASE LEVER ON RELEASE SHAFT AND SEAT SHAFT UNDER DETENT FLANGE IN DETENT HOUSING. SIMULTANEOUSLY INSERT DETENT HOUSING GROUP AND DETENT RELEASE LEVER HOUSING GROUP IN POSITION, AND INSTALL DETENT RELEASE LEVER CAP AND 2 SCREWS. TIGHTEN TO 85-100 POUNDS-INCH.
4. INSTALL COVER, PLUNGER, AND HOUSING CAP ON DETENT HOUSING, AND FASTEN WITH 6 SCREWS.
5. LIGHTLY TIGHTEN (APPROX. 40 POUNDS-INCH) TWO CENTER SCREWS IN DETENT HOUSING COVER, THEN BACK OFF 1/4 TURN.
6. OPEN AND CLOSE BREECH MECHANISM FOUR TO SIX TIMES TO ALLOW DETENT HOUSING TO CENTER ITSELF. LEAVE BREECH IN UNLOCKED, READY TO BACK OUT POSITION. ALTERNATELY TIGHTEN DIAGONALLY OPPOSITE SCREWS TO 95-110 POUNDS-INCH. TIGHTEN CENTER SCREWS TO 95-110 POUNDS-INCH. CHECK FOR FREEDOM OF DETENT MOVEMENT BY FULLY OPENING AND CLOSING BREECH MECHANISM. LOOSEN SCREWS IN DETENT HOUSING AND REPEAT PROCEDURE IF DETENT SYSTEM DOES NOT OPERATE FREELY.
7. CLOSE AND LOCK BREECH. ADJUST RELEASE LEVER SETSCREWS (FIG. 11-23).

(SEE TABLE 8-17.1 FOR SERVICING INTERVAL).

AR 900676

Figure 11-22. Removal/installation ammunition detent and components (early design--type I).

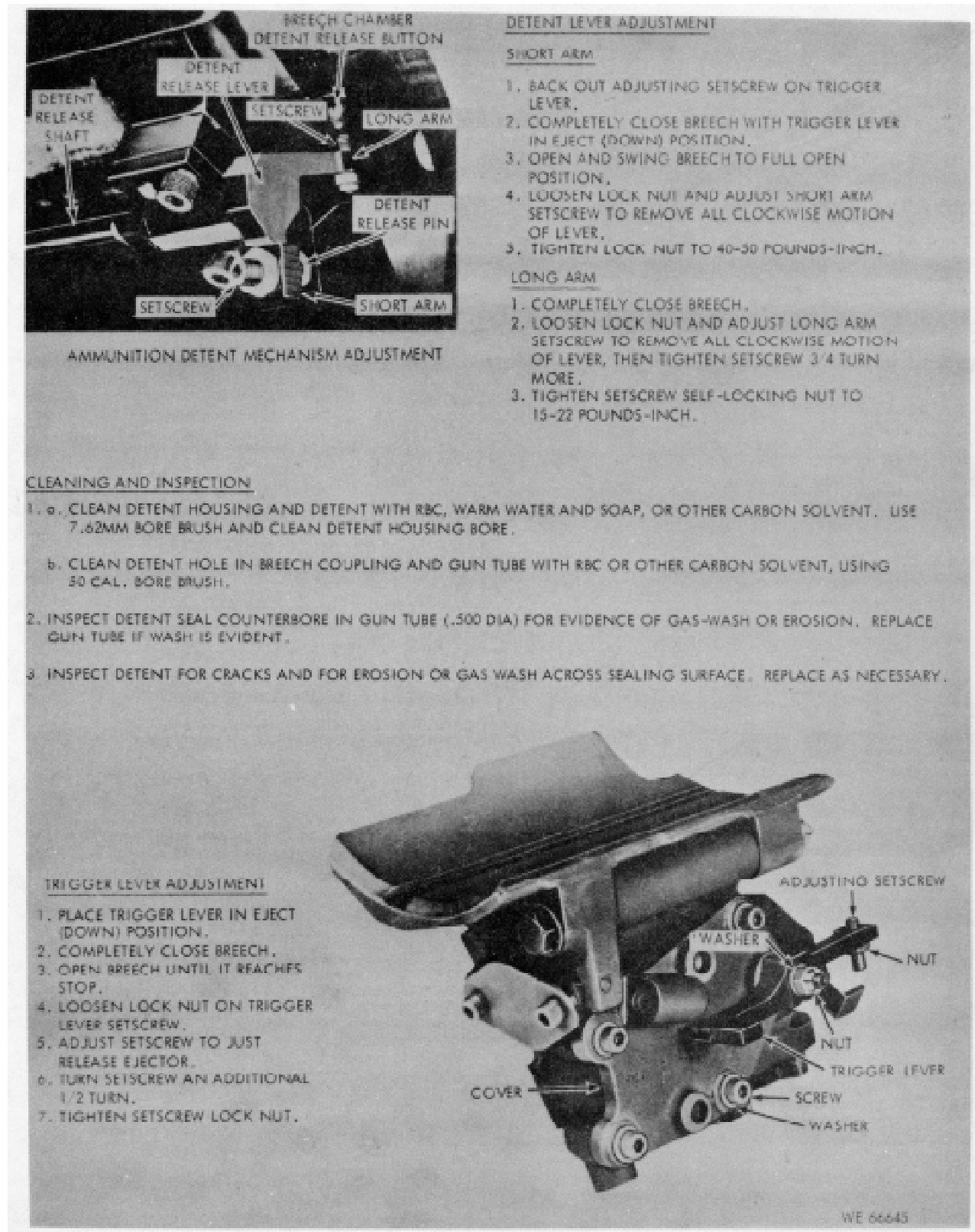
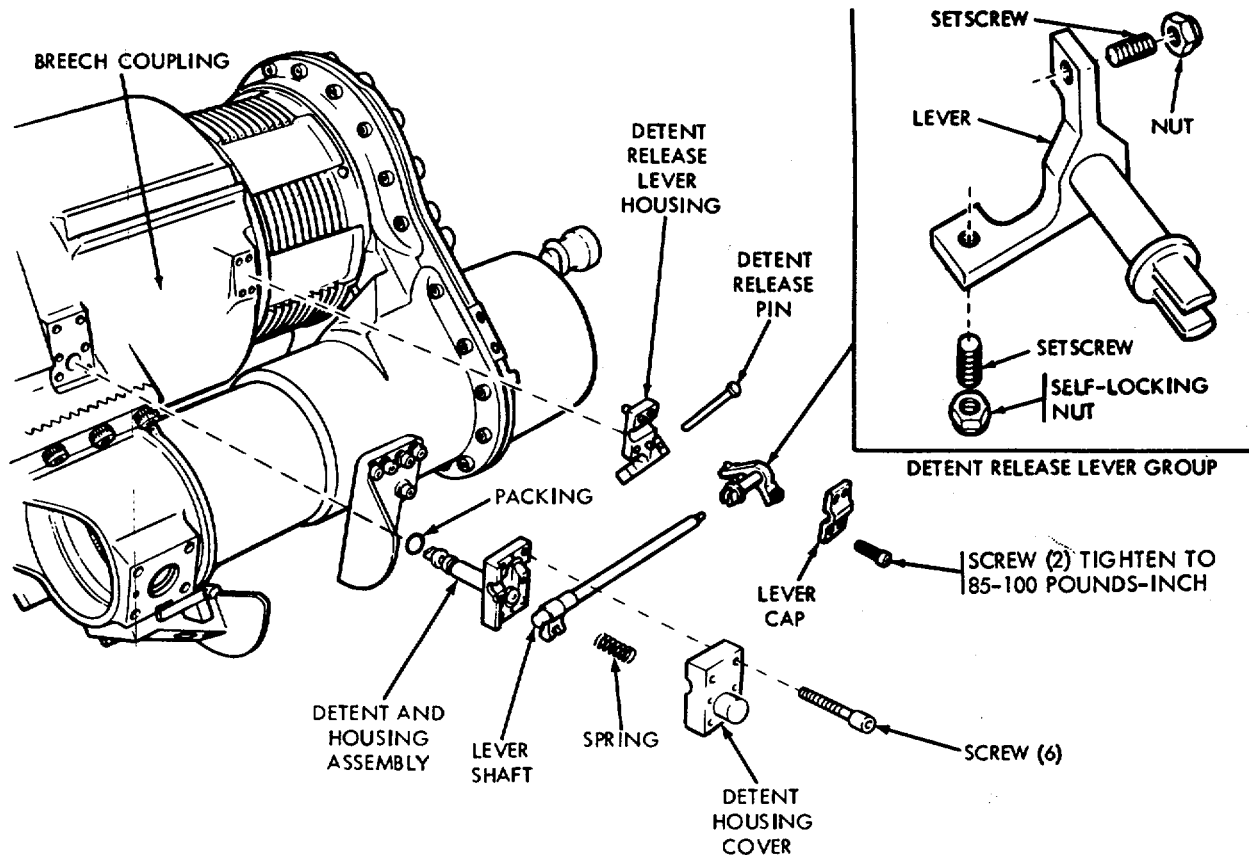

Figure 11-23. Cleaning/inspection/adjustment trigger lever and early design (type I) ammunition detent.)



#### REMOVAL

1. REMOVE 2 SCREWS FROM LEVER SHAFT HOUSING AND 6 SCREWS FROM DETENT HOUSING COVER.
2. REMOVE DETENT HOUSING COVER, SPRING, LEVER, LEVER SHAFT AND LEVER.
3. INSTALL 2 OF THE DETENT SCREWS IN JACKSCREW HOLES OF DETENT HOUSING AND CAREFULLY JACK DETENT HOUSING FREE OF GUN TUBE, TURNING SCREWS EQUALLY. REMOVE DETENT AND DETENT HOUSING.
4. DISASSEMBLE, (FIG. 11-23.2) CLEAN AND INSPECT (FIG. 11-23.3) DETENT AND DETENT HOUSING.

#### INSTALLATION

1. ASSEMBLE DETENT TO DETENT HOUSING (FIG. 11-23.2).
2. INSTALL NEW PREFORMED PACKING IN SEAL GROOVE OF DETENT HOUSING AND LIGHTLY APPLY LUBRICANT MIL-L-46150
3. LOOSELY INSTALL SETSCREW AND LOCK NUT IN DETENT RELEASE LEVER SHORT ARM AND SETSCREW WITH SELF-LOCKING NUT IN LONG ARM. INSTALL DETENT RELEASE PIN IN DETENT RELEASE LEVER HOUSING.
4. ASSEMBLE DETENT RELEASE LEVER ON LEVER SHAFT AND SEAT IN DETENT HOUSING. INSTALL DETENT RELEASE LEVER CAP AND 2 SCREWS.

5. INSTALL DETENT HOUSING GROUP AND DETENT RELEASE LEVER HOUSING GROUP ON BREECH COUPLING. TIGHTEN SCREWS IN LEVER CAP TO 85-100 POUNDS-INCH.
6. LIGHTLY TIGHTEN (APPROX. 40 POUNDS-INCH) TWO CENTER SCREWS IN DETENT HOUSING COVER, THEN BACK OFF 1/4 TURN.
7. OPEN AND CLOSE BREECH MECHANISM FOUR TO SIX TIMES TO ALLOW DETENT HOUSING TO CENTER ITSELF. LEAVE BREECH IN UNLOCKED, READY TO BACK OUT POSITION. ALTERNATELY TIGHTEN DIAGONALLY OPPOSITE SCREWS TO 95-110 POUNDS-INCH. TIGHTEN CENTER SCREWS TO 95-110 POUNDS-INCH. CHECK FOR FREEDOM OF DETENT MOVEMENT BY FULLY OPENING AND CLOSING BREECH MECHANISM. LOOSEN SCREWS IN DETENT HOUSING AND REPEAT PROCEDURE IF DETENT SYSTEM DOES NOT OPERATE FREELY.
8. CLOSE AND LOCK BREECH. ADJUST RELEASE LEVER SETSCREWS (FIG. 11-23.3).

REFER TO TABLE 8-17.1 FOR SERVICING INTERVAL.

Figure 11-23.1. Removal/installation ammunition detent assembly (late design--type II).

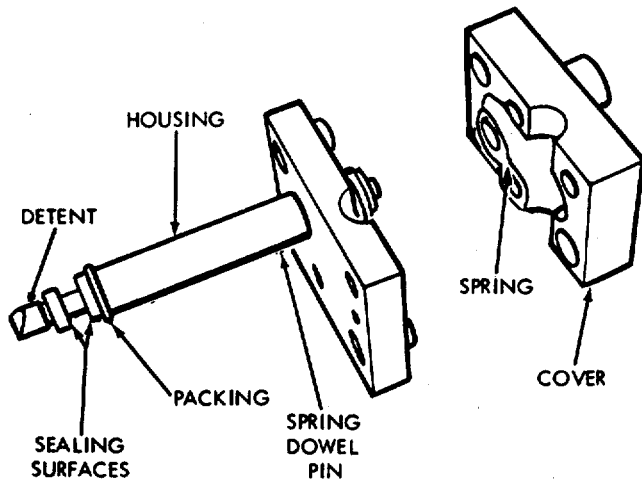

A. DETENT ASSEMBLY AND COVER

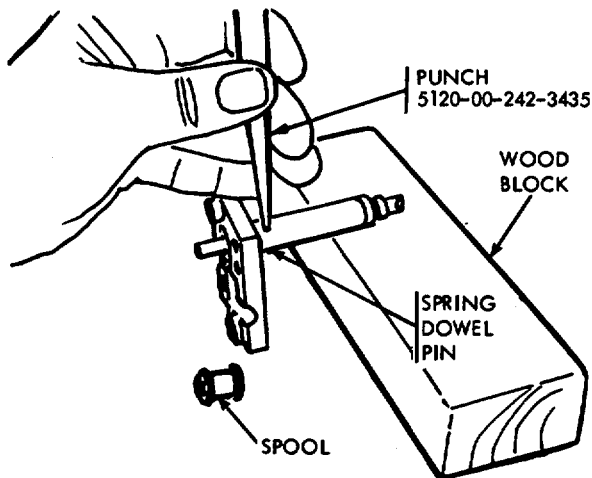

B. REMOVING DOWEL PIN

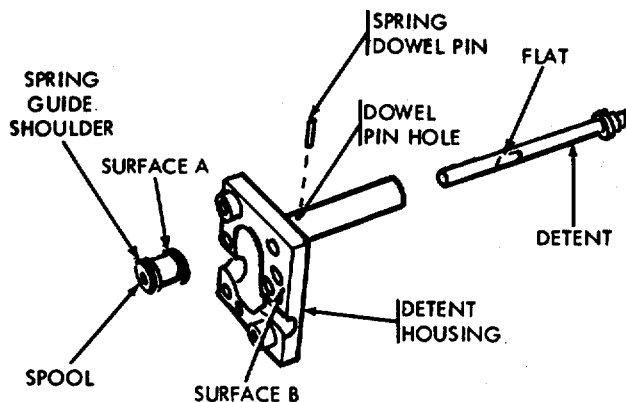

C. DISASSEMBLED VIEW

**DISASSEMBLY**

1. REMOVE DETENT AND HOUSING ASSEMBLY (FIG. 11-23.1).
2. REMOVE AND DISCARD PREFORMED PACKING FROM DETENT HOUSING (VIEW A).
3. UNSCREW SPOOL FROM DETENT.
4. SUPPORT HOUSING ON A BLOCK OF WOOD APPROXIMATELY 1-1/4 INCHES THICK AS SHOWN IN VIEW C. USE 3/32 DIAMETER PUNCH TO DRIVE SPRING PIN OUT OF HOUSING.
5. REMOVE DETENT FROM HOUSING FOR CLEANING AND INSPECTION (FIG. 11-23.3).

**ASSEMBLY**

1. INSTALL DETENT IN HOUSING WITH FLAT OF DETENT ALIGNED WITH DOWEL PIN HOLES OF HOUSING. DO NOT LUBRICATE DETENT METAL COMPONENTS.
2. SUPPORT HOUSING ON WOOD BLOCK AS IN STEP 4 ABOVE.
3. EXAMINE DOWEL PIN AND REPLACE IF DISTORTED (MS171526, .125 X .500).
4. START SPRING DOWEL PIN INTO DOWEL HOLE IN HOUSING WITH SLOT ORIENTED AWAY FROM FLAT OF DETENT SHAFT.
5. KEEP SHARP EDGE OF DETENT VERTICAL WHILE TAPPING DOWEL PIN THROUGH HOUSING WITH SOFT METAL HAMMER UNTIL PIN PROTRUDES APPROXIMATELY EQUALLY, TOP AND BOTTOM.
6. THREAD SPOOL ONTO DETENT WITH SPRING GUIDE SHOULDER AWAY FROM DETENT.
7. SCREW SPOOL ONTO DETENT UNTIL SURFACE "A" OF SPOOL IS FLUSH WITH SURFACE "B" OF HOUSING WITH DETENT FULLY RETRACTED (CHECK WITH STRAIGHT EDGE).
8. BACK SPOOL OFF DETENT (NOT MORE THAN 1/2 TURN) TO ALIGN FLATS OF SPOOL PARALLEL TO SIDES OF HOUSING.
9. INSTALL NEW PREFORMED PACKING IN GROOVE OF DETENT HOUSING. LIGHTLY APPLY LUBRICANT MIL L 46150 TO PACKING.
10. INSTALL DETENT AND HOUSING ASSEMBLY ON GUN LAUNCHER (FIG. 11-23.1). ADJUST LINKAGE (FIG. 11-23.3).

WE 70026

Figure 11-23.2. Disassembly/assembly ammunition detent (late design--type II) and housing assembly.

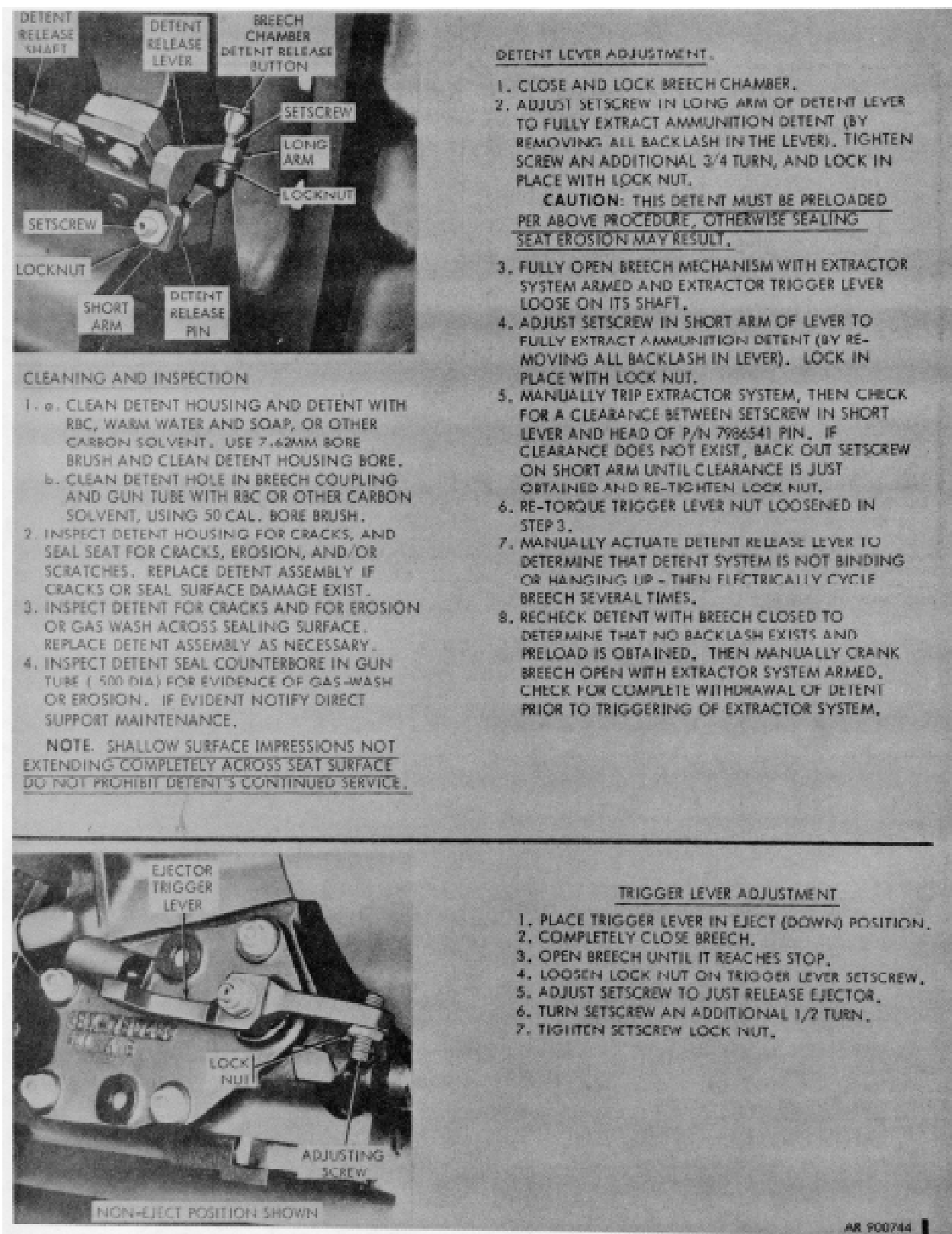

Figure 11-23.3. Cleaning/inspection/adjustment trigger lever and late design ammunition detent (type III).

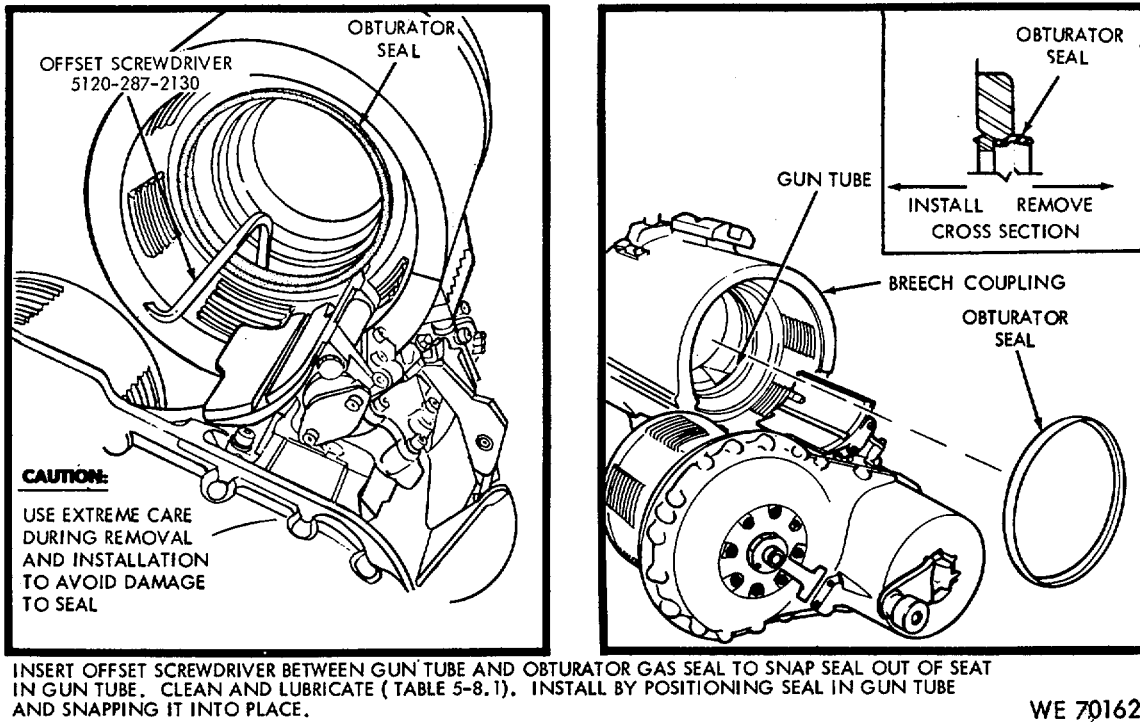

Figure 11-24. Removal/installation - obturator seal'

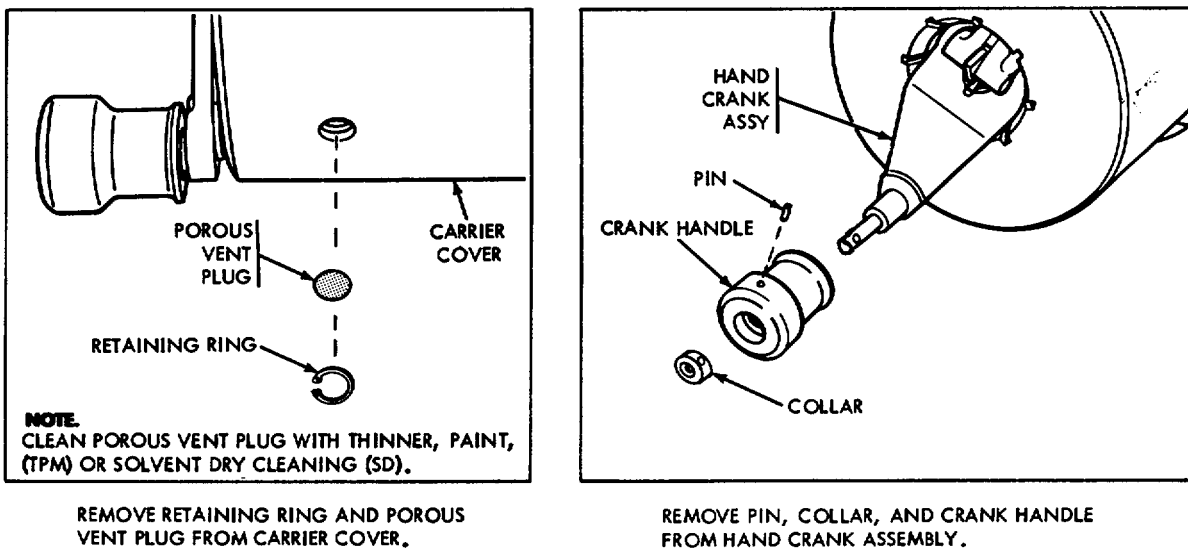

Figure 11-25. Removal/installation carrier cover vent plug and manual drive crank handle.



**Section 11-2. SECONDARY ARMAMENT**

**11-2. General**

This section contains instructions for organizational maintenance of the M176 grenade launcher mounts as shown in table 11-3.

**11-3. Machine Gun Cleaning Instructions**

a. Refer to TM 9-1005-233-25 for maintenance of 62-mm machine gun M73, M73A1, or M219.

b. Refer to TM 9-1005-213-25 for maintenance of cal. 50 machine gun M2.

*TABLE 11-3. M176 GRENADE LAUNCHER*

ASSEMBLY OR COMPONENT	FIGURE REFERENCE	
	REMOVE/INSTALL	ADJUST
Tube Assembly Solenoid	11-25.3	11-25.4

Table 11-4 and figures 11-25.1 and 11-25. 2 - deleted.

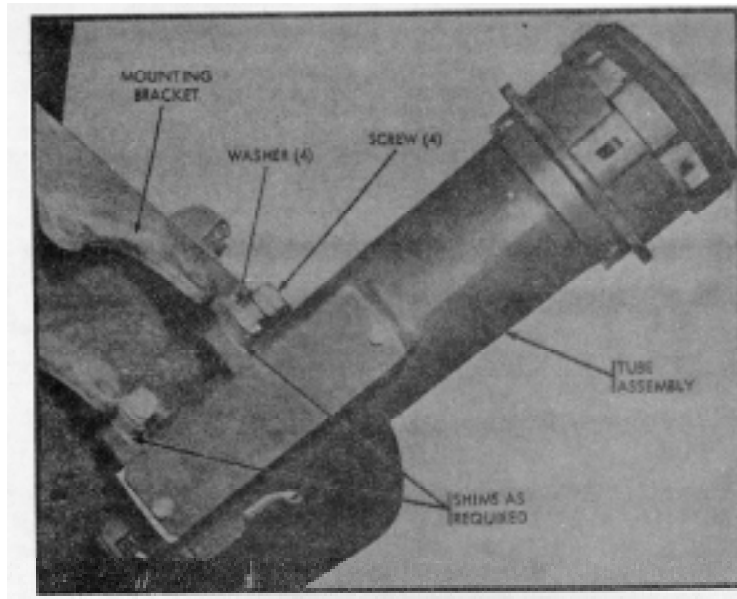

### **PRELIMINARY STEPS**

- A. OBTAIN TWO 3/8 HEXAGON TOOL STEEL PIECES, APPROXIMATELY 6 INCHES AND 2 INCHES IN LENGTH, TO FACILITATE REMOVAL AND INSTALLATION OF MOUNTING SCREWS.
- B. TURN GRENADE LAUNCHER CONTROL PANEL MASTER SWITCH OFF AND INSTALL SAFETY WIRE.
- C. TURN CONTROL PANEL FIRE SWITCH OFF AND INSERT SAFETY PIN.
- D. REMOVE LAUNCHER FROM TUBE ASSEMBLY (FIG. 3-15.1).
- E. REMOVE CABLE CHANNEL AND DISCONNECT SOLENOID LEAD.

### **REMOVAL**

1. REMOVE 2 UPPER MOUNTING SCREWS AND WASHERS (AND SHIMS IF PREVIOUSLY USED) USING 2 INCH HEXAGON TOOL.
2. USE 6 INCH HEXAGON TOOL TO REACH LOWER SCREWS THROUGH UPPER BRACKET HOLES. REMOVE 2 SCREWS, WASHERS (AND SHIMS IF PREVIOUSLY USED) AND TUBE ASSEMBLY.

### **INSTALLATION**

1. HOLD TUBE ASSEMBLY IN PLACE AGAINST BRACKETS AND INSTALL LOWER SCREWS AND LOCK WASHERS. TIGHTEN TO 5 TO 10 POUNDS-FEET.
2. INSTALL ONE TOP SCREW AND LOCK WASHER AND TIGHTEN TO 5 TO 10 POUNDS-FEET.
3. USE FEELER GAGE TO DETERMINE WHERE SHIMS ARE NECESSARY, AND THICKNESS OF SHIMS REQUIRED.
4. REMOVE SCREWS AS NECESSARY TO INSTALL SHIMS, THEN INSTALL BOTTOM SCREWS AND LOCK WASHERS FIRST. KEEP ONE UPPER SCREW IN PLACE WHILE TIGHTENING BOTTOM SCREWS TO MAINTAIN ALIGNMENT OF TUBE ON BRACKET. TIGHTEN BOTTOM SCREWS TO 75 POUNDS-FEET.
5. INSTALL UPPER SCREWS AND LOCK WASHERS, WITH SHIMS AS REQUIRED. TIGHTEN TO 75 POUNDS-FEET.
6. CHECK SOLENOID ADJUSTMENT (FIG. 11-25.4).
7. CONNECT SOLENOID ELECTRICAL LEADS AND INSTALL CABLE CHANNEL (FIG. 11-25.4).

WE 70041 I

*Figure 11-25. 3. Removal/Installation - grenade launcher tube assembly.*

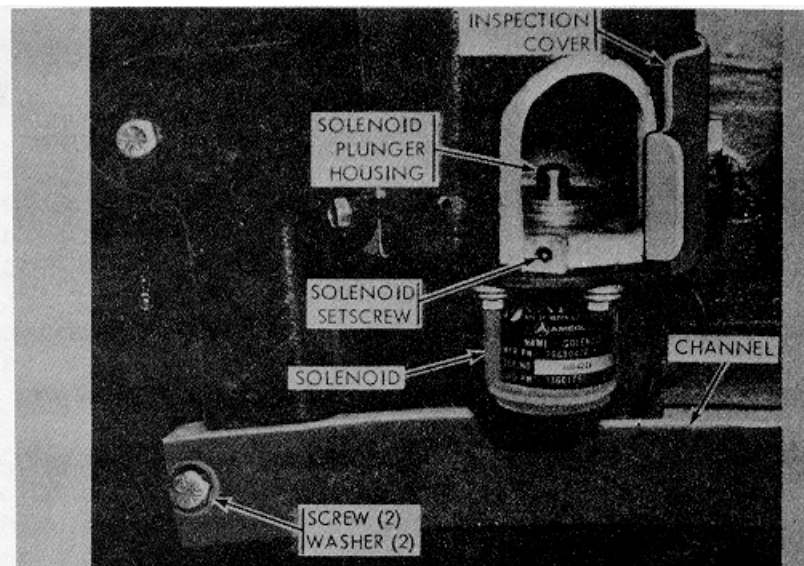

#### PRELIMINARY

- A. INSERT SAFETY PIN IN FIRE SWITCH GUARD ON GRENADE LAUNCHER CONTROL BOX.
- B. TURN MASTER SWITCH OFF AND INSTALL SAFETY WIRE.
- C. MAKE CERTAIN SPENT LAUNCHER IS PRESENT IN TUBE ASSEMBLY BEFORE PROCEEDING WITH ADJUSTMENT BELOW.

#### ADJUSTMENT PROCEDURE

1. OPEN INSPECTION COVER AND CHECK TO SEE THAT LAUNCHER IS PROPERLY SEATED ON SOLENOID.
2. TURN LOCKING LEVER RING TO LOCKED POSITION (FIG. 3-15.1).
3. CHECK POSITION OF TOP RIM OF LAUNCHER RELATIVE TO LOCKING LEVERS IN TUBE. RIM OF LAUNCHER SHOULD BE BELOW LOCKING LEVERS BUT IN FIRM CONTACT. IF ADJUSTMENT IS REQUIRED, PROCEED WITH STEPS 4 THROUGH 10.
4. LOOSEN SOLENOID SETSCREW.
5. REMOVE CABLE CHANNEL AND DISCONNECT SOLENOID ELECTRICAL LEAD.
6. ADJUST HEIGHT OF SOLENOID BY TURNING (CLOCKWISE TO RAISE, COUNTERCLOCKWISE TO LOWER) UNTIL RIM OF LAUNCHER IS PRESSED FIRMLY AGAINST LOCKING LEVERS.

NOTE. AT FINAL ADJUSTMENT, ELECTRICAL LEAD FROM SOLENOID MUST LEAD OUT OF SOLENOID TOWARD TURRET.

7. TURN LOCKING LEVER RING TO UNLOCKED POSITION AND BACK TO LOCKED POSITION. CHECK TO SEE THAT LOCKING LEVERS PROPERLY ENGAGE RIM OF LAUNCHER.
8. TIGHTEN SOLENOID SETSCREW AND CLOSE INSPECTION COVER.
9. CONNECT SOLENOID ELECTRICAL LEAD.
10. INSTALL CABLE CHANNEL.

WE 70877 I

Figure 11-25.4. solenoid adjustment- grenade launcher tube assembly.

Figures 11-26 thru 11-34—deleted

**Section 11-3. SIGHTING AND FIRE CONTROL****11-4. General**

a. This section contains organizational maintenance instructions for the sighting and fire control components. Refer to table 11-5 for figure references to maintenance of all components on the M551. See paragraph 11-5 for instructions for purging the laser range finder units on the M551A1.

b. Refer to table 11-6 for instructions on synchronization of XM44 series periscope and linkage, using an outdoor method.

c. Refer to TMs 9-2350-23010/2-1 and 9-2350-230-10-2-3 for boresighting procedures on all sighting and fire control instruments on the M551 and M551A1, respectively.

**11-5. Purging Laser Range Finder Units (M551A1 Only)**

a. Laser range finder units must be purged with dry nitrogen at 90-day intervals to prevent condensation of moisture.

b. Use purging adapter kit supplied for the M551 series vehicles.

c. The fill valve (or entrance port) on each unit is color-coded gray; the relief valve (or escape port), yellow.

d. Purge the laser range finder units as follows:

(1) Remove the fill valve cap or plug screw from the unit fill valve (or entrance port).

(2) Open escape port of the unit to be purged (except on the receiver-transmitter) by removing the plug screw. The receiver-transmitter has a relief valve and does not require removal of a plug screw. The relief valve will pop open when a pressure greater than 4 psi is applied to it.

(3) Using the appropriate adapter, attach one end of the purging adapter kit to the nitrogen cylinder and the other end to the fill valve or entrance port.

(4) Turn the tank valve on the nitrogen cylinder counterclockwise to open.

(5) Set the pressure regulator to 7 psi +2

(6) Open control valve on the purging adapter kit to allow nitrogen to flow through the unit for approximately 10 minutes for all units except the receiver-transmitter. Allow nitrogen to flow through the receiver-transmitter for 30 minutes.

(7) Close the control valve on the purging kit.

(8) Remove the purging adapter kit from the laser range finder unit.

(9) Immediately reinstall valve cap (at fill valve) on receiver-transmitter; on other units, install plug screws at entrance and escape ports.

(10) Close valve on the nitrogen tank. Relieve pressure in the purging equipment

by opening its valve and turning the pressure regulator control counterclockwise until regulator gages indicate zero.

Table 11-5. Sighting and Fire Control Components

ASSEMBLY OR COMPONENT	FIGURE REFERENCE		
	Service adjust	remove / install	Replace
M37 Loader's Periscope Mount and Seal		11-35	
M47/48 Driver's Periscope, Mount, Seal, and Wiper		11-36	11-36
M47/48 Driver's Periscope Washer, Pump, and Reservoir		11-37	
Azimuth Indicator and Switch Assembly		11-38	
M1A1 Gunner's Quadrant	2-28		
M119 or M127 Telescope Headrest, Hanger, and Telescope	11-40		
M149 or M165 Telescope Mount	11-40.1		
Telescope 1Mount Mounting Bracket Bolts	11-40.1.1		
M13A1C Elevation Quadrant	2-28	11-40.2	
XM44 Series Periscope Body and Head		11-41,11-41.1	
Servicing XM44 Series Periscope Emergency Battery	11-41.3		
XM44 Series Periscope Washer, Pump, Reservoir, and Wiper Blade		11-42	
XM44 Series Periscope Linkage		11-43	

Pages 11-31 and 11-32--deleted.

TABLE 11-6. SYNCHRONIZATION OF XM44/E1 PERISCOPE BY OUTDOOR METHOD

Step No.	Procedure
1	Locate vehicle on level ground with rear of vehicle adjacent to an incline or ramp and approximately 1200 meters from a suitable target. The incline should be of an angle so that vehicle can be positioned with the front end downward approximately 350 mils from horizontal. Target should be near horizontal line of sight to avoid a large elevation angle.
2	Secure muzzle boresight (black thread) in reference marks on gun muzzle and secure with strap or tape (A, Fig. 2-23).
3	Open breech and insert breech boresight assembly. Position right telescope of binocular M17A1 over hole of breech boresight assembly and select a distant aiming point(1200 meters) with sharply defined vertical and horizontal lines.
4	<p>Prepare the gunner's XM44/E1 periscope for use as follows:</p> <p><b>CAUTION:</b> <u>Use XM44/E 1 periscope boresight aid (10516830) when boresighting in daylight. Use dark position filter to prevent excessive light from damaging internal components.</u></p> <p>a. Open the ballistic shield by depressing handle finger latch, actuating handle and releasing finger latch. Install boresight aid.</p> <p>b. Turn periscope light switch on XM44/E 1 periscope control panel to "ON" position.</p> <p><b>CAUTION:</b> <u>Do not direct periscope toward sun when periscope is on; excessive light will damage internal components.</u></p> <p>c. Adjust headrest. View through eyepiece and select dark position filter with filter lever.</p> <p>d. Turn focus knob to maximum counterclockwise position and turn diopter knob to obtain sharpest image on screen.</p> <p>e. View image on screen for proper illumination and move filter lever to provide most effective filter for image illumination.</p> <p>f. Turn and adjust XM44E1 periscope control panel rheostat knob clockwise for proper illumination of reticle pattern.</p>
5	Lay the gun tube on the target aiming point by laying low to high without over-travel. (Always lay gun low to high to eliminate backlash from the system.)
6	<p><b>NOTE</b> 1. Both boresight knobs contain spring loaded clutch teeth requiring "pull to turn" operation. This feature provides accurate boresight retention. Align vertical center line of reticle on aiming point by use of azimuth boresight knob (fig. 2-26). Slip scale on face of knob to "4".</p> <p>2. Both elevation and azimuth knobs have approximately 15 mils of adjustment or approximately two turns of adjustment. One revolution of the knob is 8 mils. Each line between numbers is 0.1 mil.</p>

TABLE 11-6. SYNCHRONIZATION OF XM44/EI PERISCOPE BY OUTDOOR METHOD (Continued)

Step No.	Procedure
7	Pull and turn elevation knob counterclockwise to end of travel. Set slip scale to "1" Pull and turn knob to "4".
8	Set both eccentric micrometers on the elevation link assembly to zero (fig. 11-43). Adjust elevation link until boresight reticle is on same aiming point as the gun tube. To adjust link, loosen two screws on connector and link and turn tube. Tighten both screws.
9	If necessary, make a final elevation adjustment with the adjusting knob on periscope. Reset the slip scale to "4".
10	Using the M1A1 gunner's quadrant placed on the breech block rail (A, fig. 2-28), elevate gun to 89 mils (5 degrees).
11	Back vehicle up incline until bubble in gunner's quadrant is centered (approximately).
12	Observe target through boresight aid pin hole and re-lay gun on target aiming point by laying low to high without over-travel.
13	With elevation boresight knob on periscope, align boresight mark of telescope reticle on the same aiming point as the cross threads of the gun tube.
14	Read and record the deviation from the initial boresight reading (4) on the elevation boresight knob scales.
15	Repeat steps 11 through 16 with gunner's quadrant settings of: 178 mils (10 degrees), 267 mils (15 degrees), 336 mils (19 degrees), and minus 124 mils (7 degrees depressed position).
16	Determine if deviations from initial readings exceed the maximum tolerance of 0.5 mil for synchronization at 0, 5, 10, 15 or 19 degrees elevation, and 7 degrees depression. If synchronization error exceeds 0.5 mil, return vehicle to position with the maximum deviation and adjust periscope line of sight, by adjusting the eccentrics on elevation link (fig. 11-43) so that one-half of error is removed.
	<p><b>NOTE.</b> <u>Inner and outer eccentrics must be -adjusted so that either red or white scales are aligned to the same index on bo' scales, i.e., red scale to red scale or white scale to white scale. From zero setting adjusting both eccentrics into red scales will lengthen the linkage and adjusting both eccentrics into white scales will shorten the linkage.</u></p>
17	Recheck boresight deviation at minus 124 mils to plus 336 mils (steps 14 and 15). Deviation now should be within tolerance at each elevation. If not, recheck steps 2 through 17.
18	If periscope cannot be synchronized, replace periscope (fig. 11-41).
19	Remove boresight equipment (steps 2, 3, and 4).
20	Turn turret control and fire control switches off. Lamps will go out.
21	Turn XM44/E1 periscope control panel rheostat knob fully counterclockwise, position dark filter in place (XM44E1 - filter to "OFF" position) and turn control panel periscope switch to "OFF" position.
22	Close XM44/E1 periscope ballistic shield.
23	Turn vehicle MASTER SWITCH to "OFF" position.
	11-34

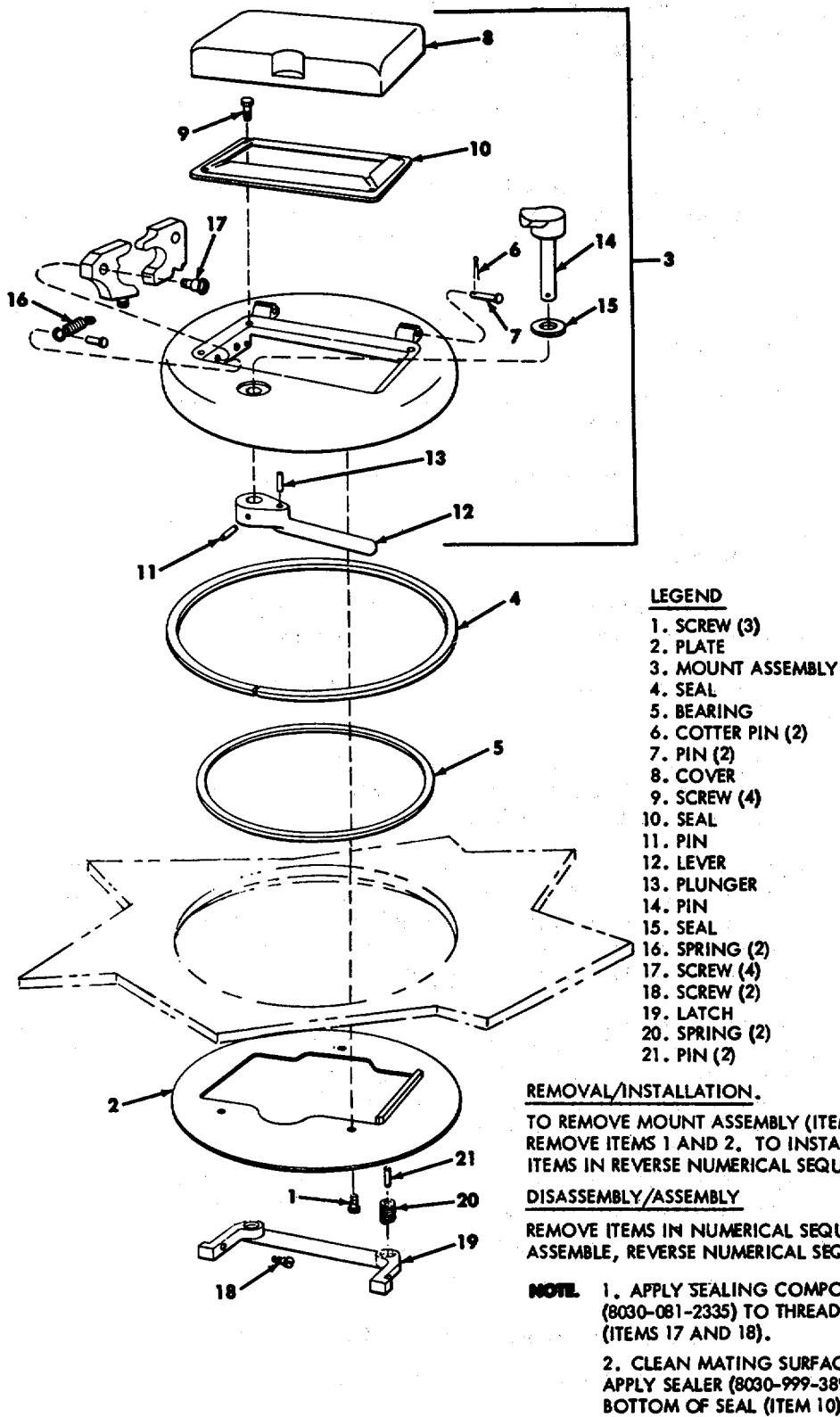

WE 11123A

Figure 11-35. Removal/disassembly/assembly/installation - M37 loader's periscope mount and seal



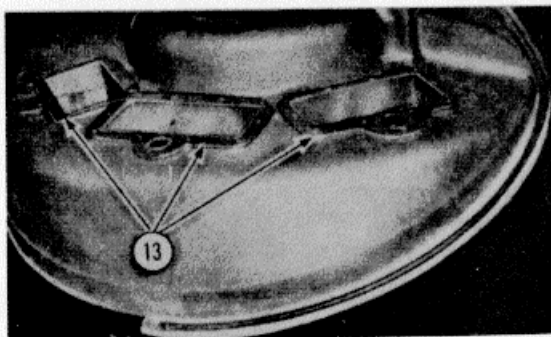
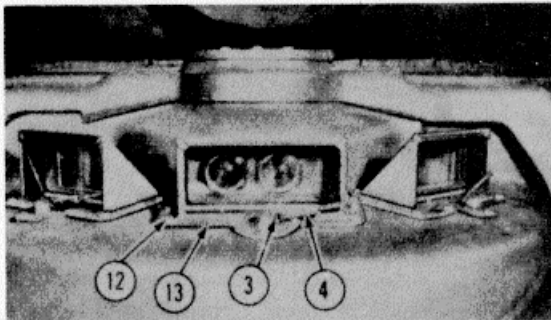
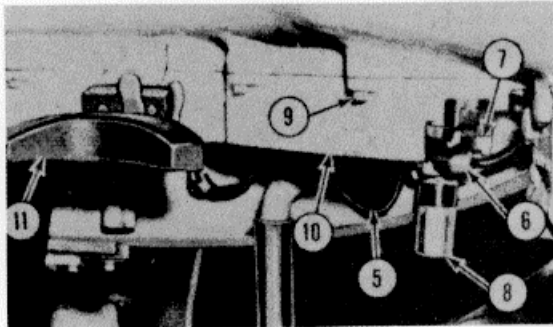
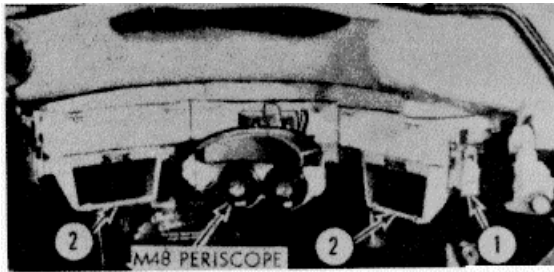

#### LEGEND

1. LATCH (6)
2. M47 PERISCOPE BODY AND HEAD (2OR 3)

**NOTE** WHEN M48 PERISCOPE BODY IS INSTALLED IN CENTER POSITION, DISCONNECT ELECTRICAL CONNECTOR BEFORE REMOVING PERISCOPE.

3. LOCK WASHER AND PIN (3)
4. WIPER BLADE (3)
5. WASHER HOSE (3)
6. ELECTRICAL CONNECTOR (3)
7. SCREW AND WASHER (6)
8. WIPER ASSEMBLY (3)
9. SCREW AND WASHER (12)
10. MOUNT (3)
11. HEADREST
12. SCREW (33)
13. SEAL (3)

#### REMOVAL

FOLLOW NUMERICAL SEQUENCE.

#### INSTALLATION

REVERSE REMOVAL PROCEDURE.

ITEM 12: APPLY SEALING COMPOUND 8030-081-2333 AND TIGHTEN TO 7-9 POUND-FEET.

ITEM 13: APPLY SEALING COMPOUND 8030-024-9634.

**NOTE** SHOULD LEAKS DEVELOP BETWEEN SEAL (13) AND PERISCOPE HEAD, APPLY SEALING TAPE 8030-262-9019 AROUND PERISCOPE HEAD AS TEMPORARY REPAIR UNTIL SEAL CAN BE REPLACED.

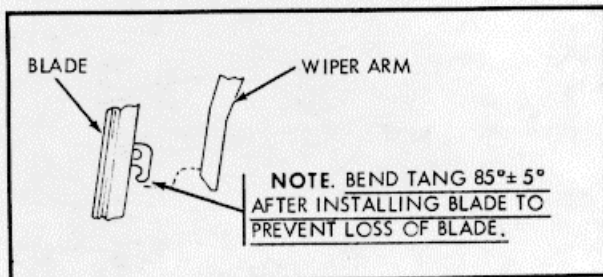

REFER TO FIGURE 2-7 INSTALLING AND OPERATING DRIVER'S M48 PERISCOPE.

WE 12184

Figure 11-36. Removal/installation - driver's M47/M48 periscope mounts, seals, and wipers

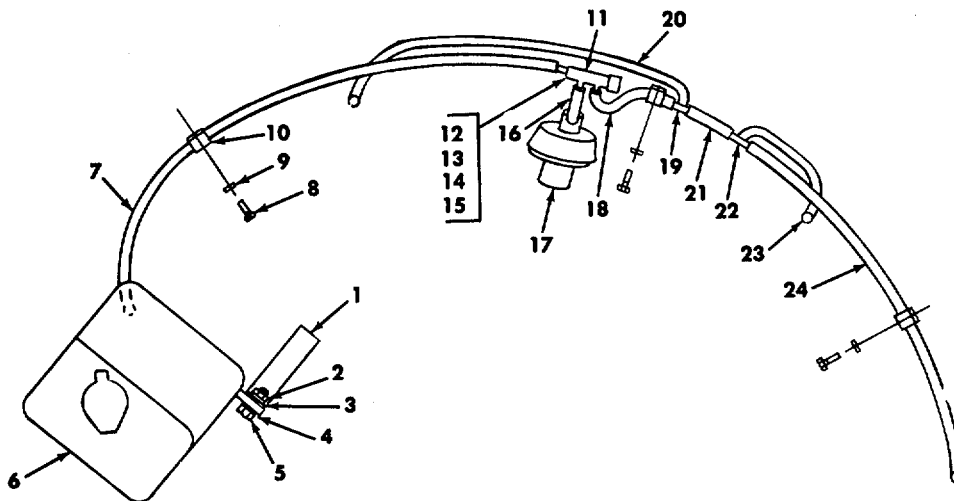
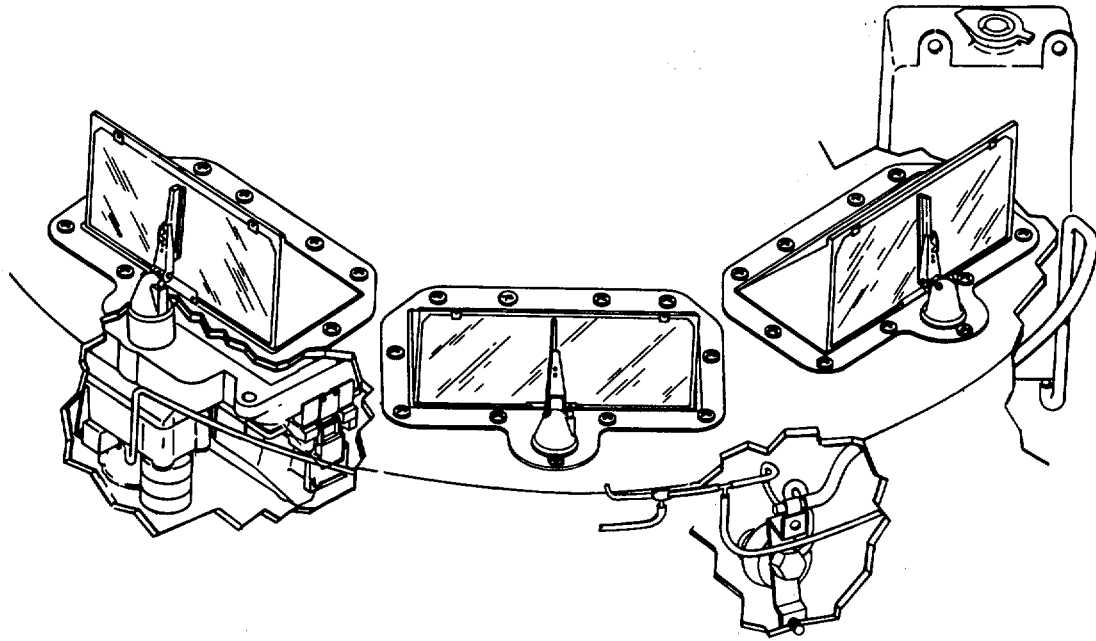

**NOTE.** WHEN REFILLING RESERVOIR USE COMBINATION SOLVENT AND ANTI-ICING FLUID MIL-A-8243.

**LEGEND**

- |                |                     |          |
|----------------|---------------------|----------|
| 1. BRACKET     | 9. WASHER (3)       | 17. PUMP |
| 2. NUT         | 10. CLAMP (3)       | 18. HOSE |
| 3. LOCK WASHER | 11. CHECK VALVE     | 19. TEE  |
| 4. FLAT WASHER | 12. SCREW (2)       | 20. HOSE |
| 5. SCREW       | 13. LOCK WASHER (2) | 21. HOSE |
| 6. RESERVOIR   | 14. CLIP            | 22. TEE  |
| 7. HOSE        | 15. WASHER          | 23. HOSE |
| 8. SCREW (3)   | 16. HOSE            | 24. HOSE |

REPLACE UNSERVICEABLE ITEMS AS REQUIRED.

WE 66571

Figure 11-37. Removal/installation - driver's M47/M48 periscope washer, pump, and reservoir

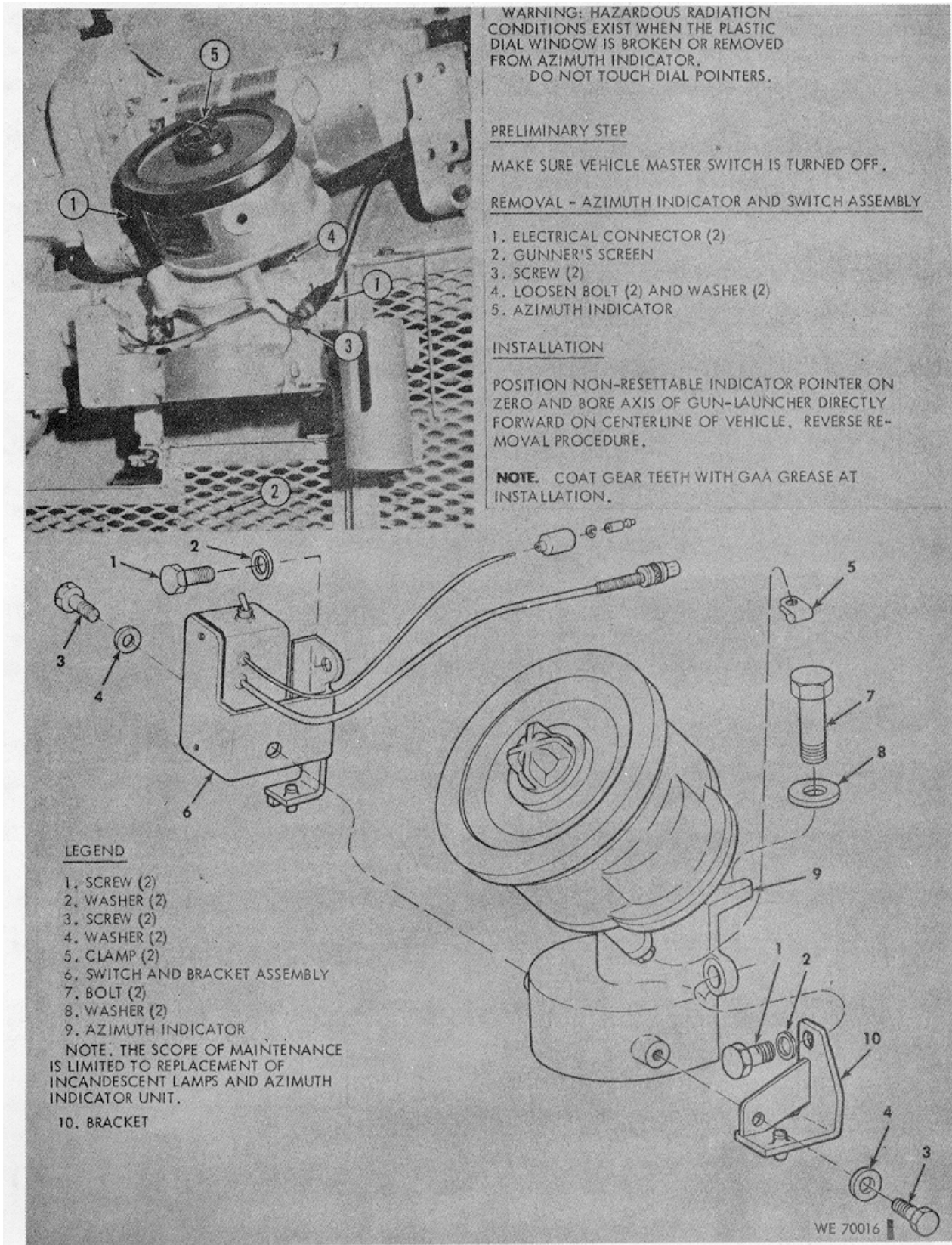

Figure 11-38. Removal/installation - azimuth indicator and switch assembly

Figure 11-39--deleted, see figure 11-40.2.

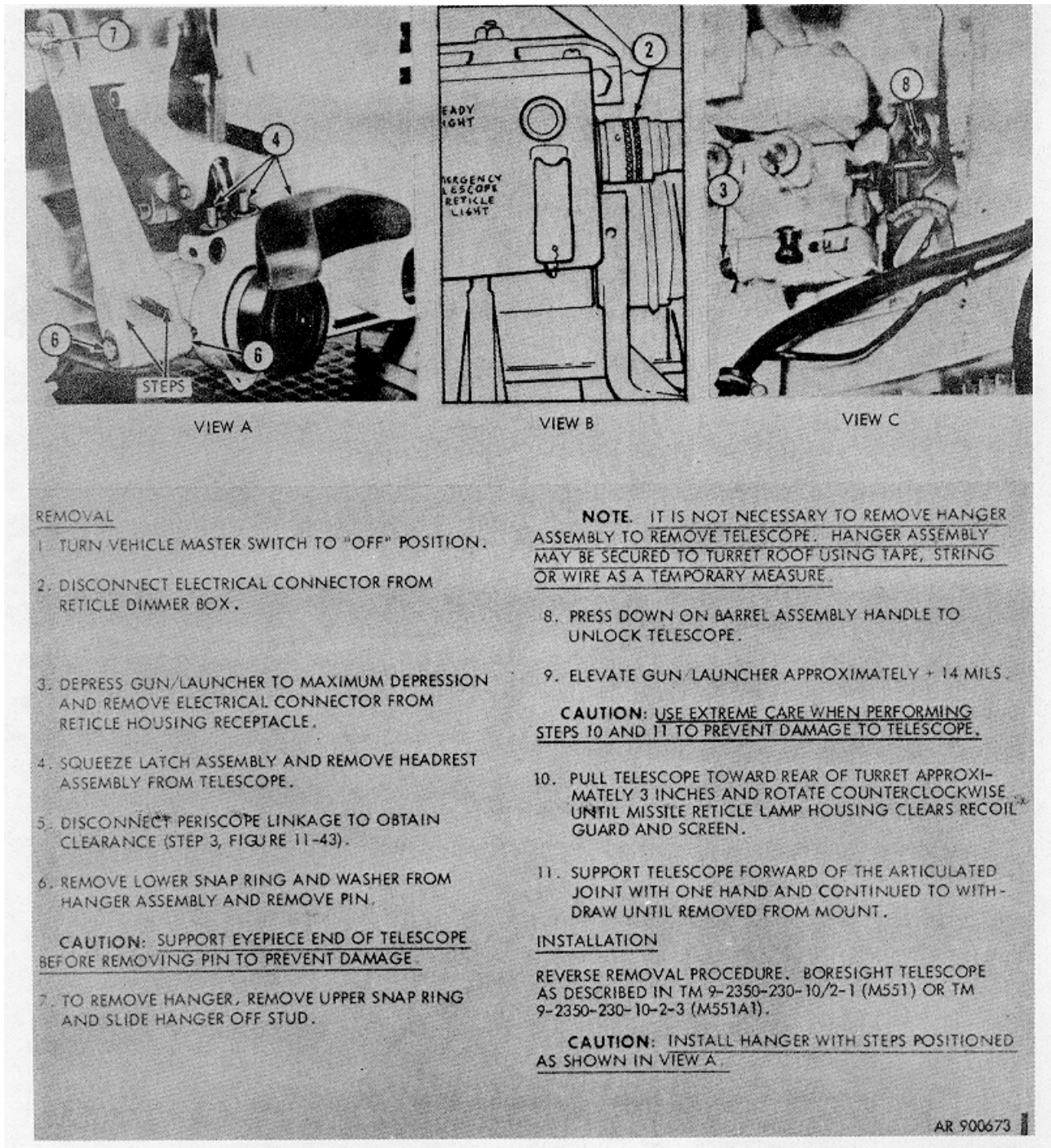

Figure 11-40. Removal/installation - M119 or M127 telescope headrest, hanger, and telescope.



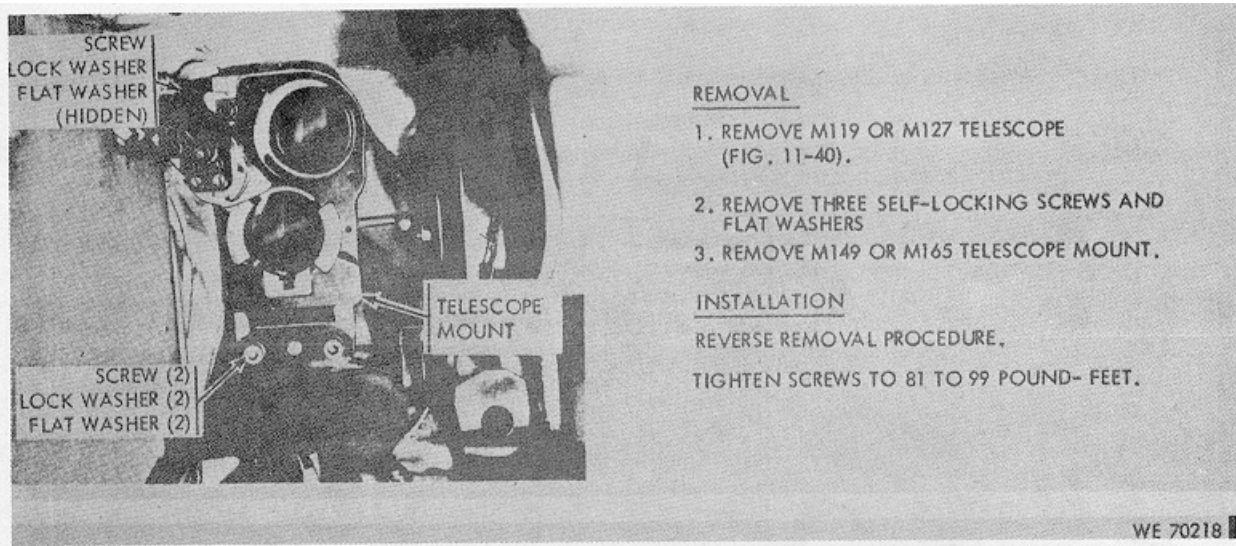
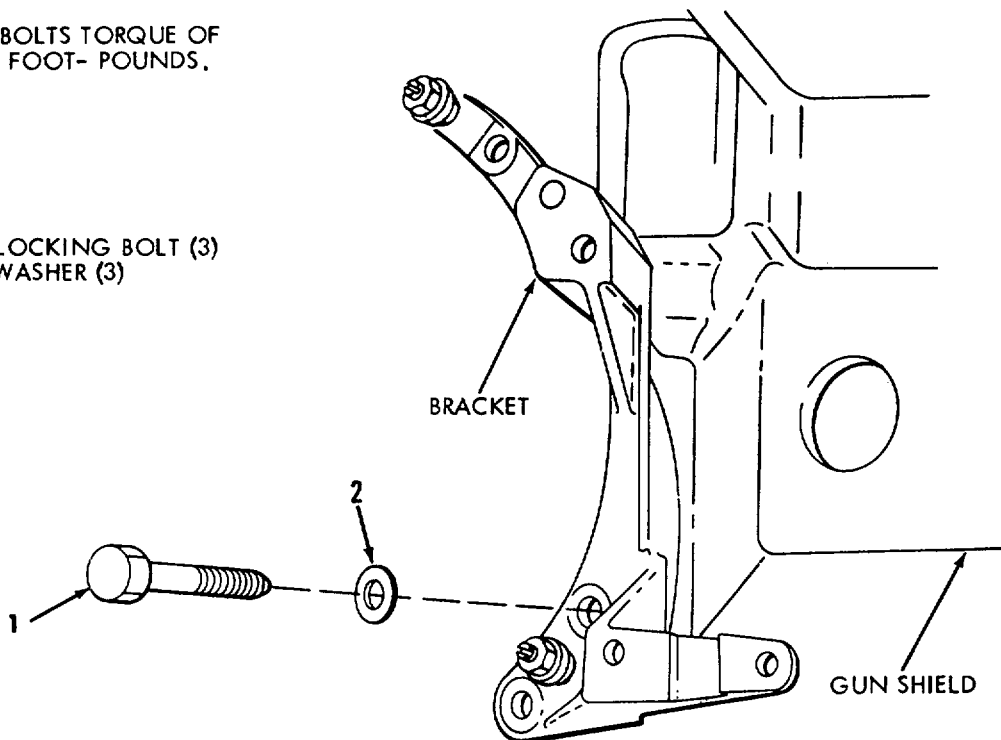

Figure 11-40.1. Removal/installation - M149 or M165 telescope mount.

**NOTE:**  
 REQUIRE BOLTS TORQUE OF  
 170 - 180 FOOT- POUNDS.

**LEGEND**

1. SELF-LOCKING BOLT (3)
2. FLAT WASHER (3)



WE 70017

Figure 11-40.1.1. Inspection of telescope mount bracket bolts.

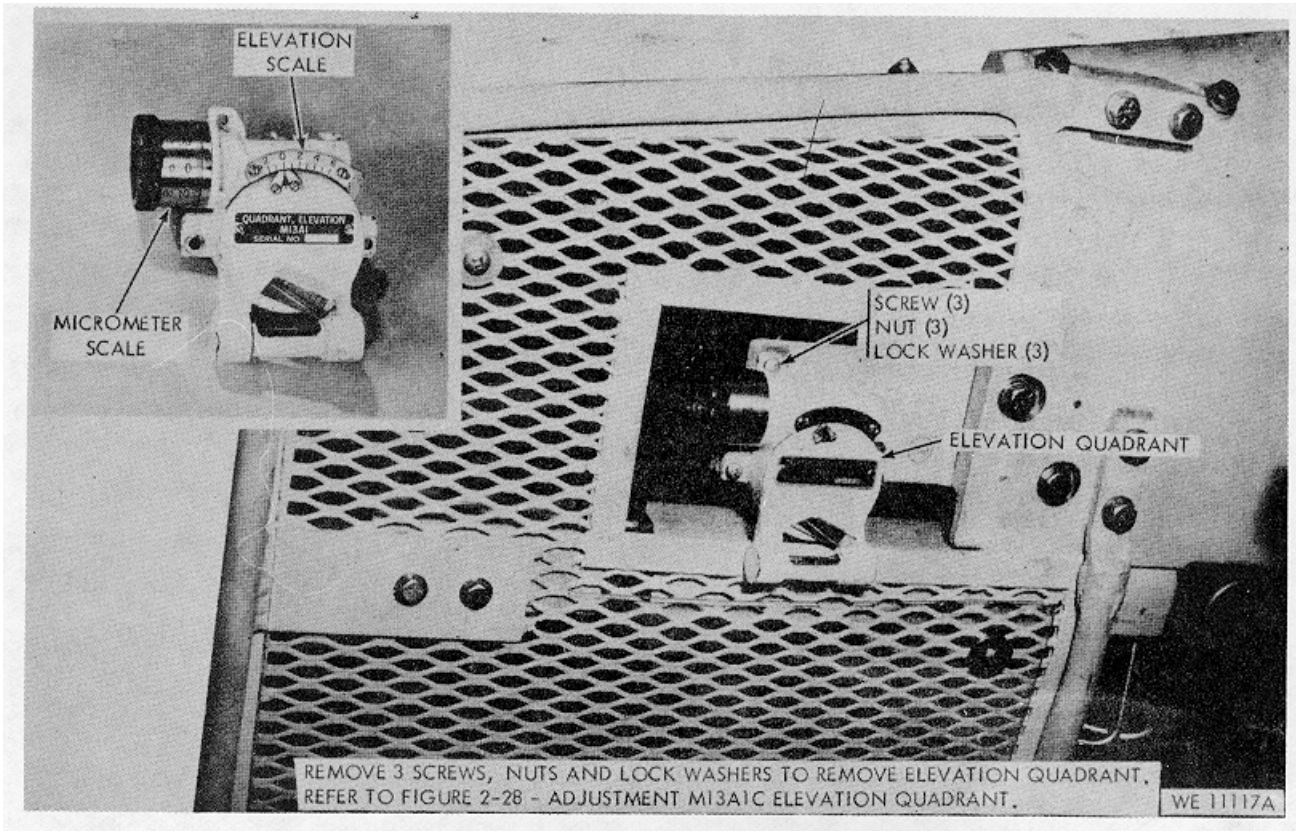
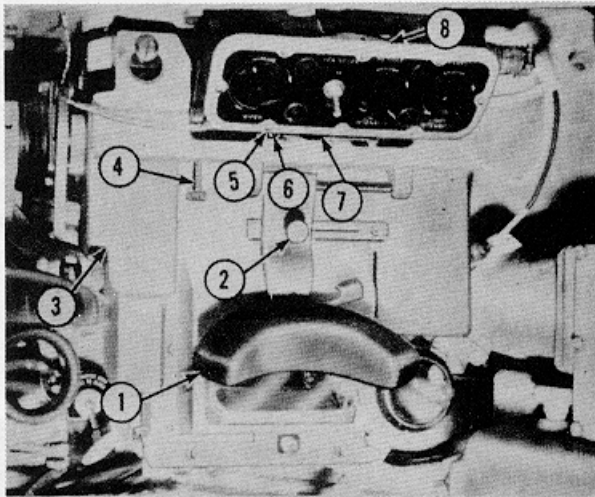
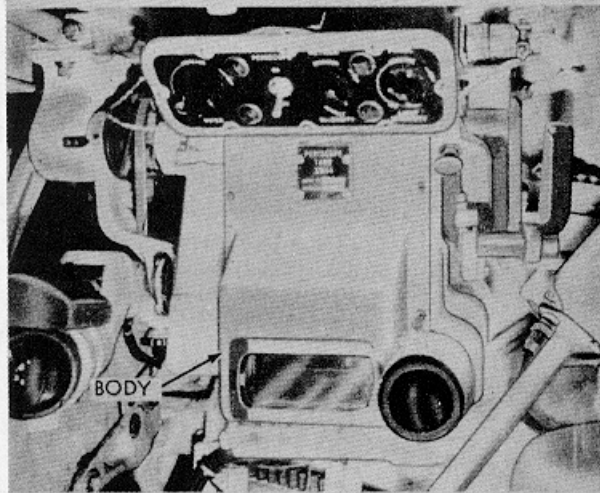

Figure 11-40. 2. Removal/installation - M13A1C elevation quadrant.

11-40. 1



HEAD REST AND ELECTRICAL PANEL



PERISCOPE BODY

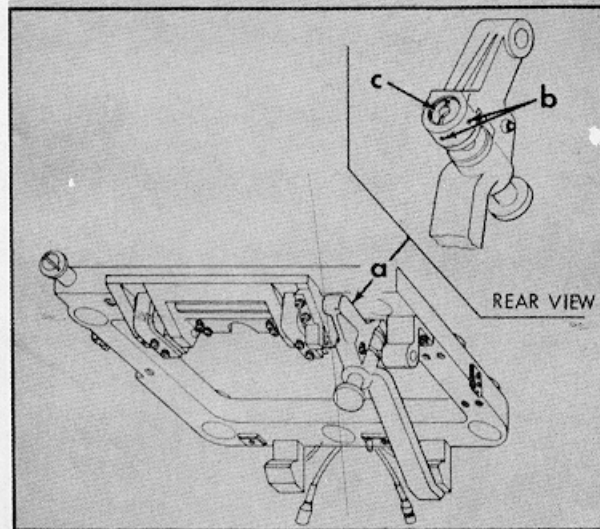

PERISCOPE BODY LOCKING LEVER ASSY

LEGEND

1. HEAD REST
2. HORIZONTAL ADJUSTMENT SCREW
3. HEAD REST MOUNTING PLATE
4. LOCKING SCREW
5. SCREW, WASHER
6. CLAMP
7. ELECTRICAL CONNECTOR
8. PERISCOPE ELECTRICAL PANEL

REMOVAL - HEAD REST AND PLATE ASSEMBLY

LOOSEN LOCKING SCREW (4), LIFT MOUNTING PLATE (3) UP, REARWARD AND DOWN.

INSTALLATION

REVERSE REMOVAL PROCEDURE.

REMOVAL - PERISCOPE BODY

**CAUTION:** BODY WEIGHS 53 POUNDS AND HEAD WEIGHS 17 POUNDS. SUPPORT CAREFULLY DURING REMOVAL TO PREVENT INJURY TO PERSONNEL OR DAMAGE TO PERISCOPE.

1. REMOVE HEAD REST PLATE ASSEMBLY (ABOVE)
2. REMOVE SCREW, WASHER (5) AND CLAMP (6)
3. DISCONNECT ELECTRICAL CONNECTOR (7)
4. SUPPORT BODY, PRESS IN ON LOCK PIN AND PULL LOCKING ASSEMBLY TO REAR.
5. LOWER BODY CAREFULLY TO PROTECT CONTROL KNOBS AND GLASS.

INSTALLATION

**CAUTION:** XM44 PERISCOPE BODY AND HEAD ASSEMBLIES ARE NOT INTERCHANGEABLE WITH XM44E SERIES.

**NOTE:** PRIOR TO INSTALLING XM44E SERIES BODY ASSEMBLY, CHECK THAT PREFORMED PACKING, MS9021-259 (5330-690-9741) IS SECURED AROUND THE ENTIRE SEAL GROOVE LOCATED IN UPPER PART OF BODY. USE ADHESIVE MIL-A-46106 TO SECURE PACKING WHEN NECESSARY.

**CAUTION:** THE LOCKING LEVER ASSEMBLY (a) MAY REQUIRE ADJUSTMENT BY LOOSENING TWO SETSCREWS (b) AND ADJUSTING STOP (c) TO ASSURE THAT THE BODY ASSEMBLY IS SECURELY LOCKED IN POSITION.

1. REVERSE REMOVAL PROCEDURE.
2. XM44E SERIES: PURGE, LEAK TEST, AND PRESSURIZE WITH DRY NITROGEN (TM 750-116).
3. BORESIGHT PERISCOPE (TABLE 2-9).

WE 70014

Figure 11-41. Removal/installation - X M44 Series periscope body and head (1 of 2)

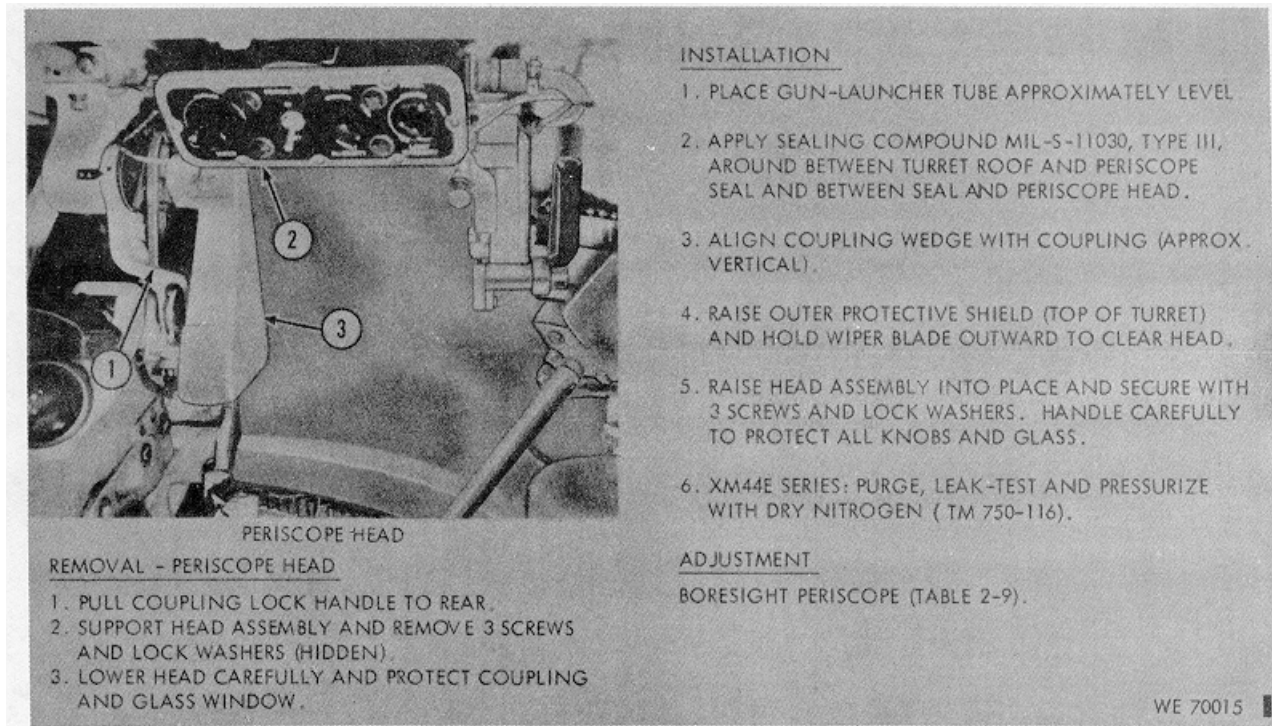

Figure 11-41.1 Removal/installation - XM44 series periscope body and head (2 of 2)

Figure 11-41. 2 - deleted.

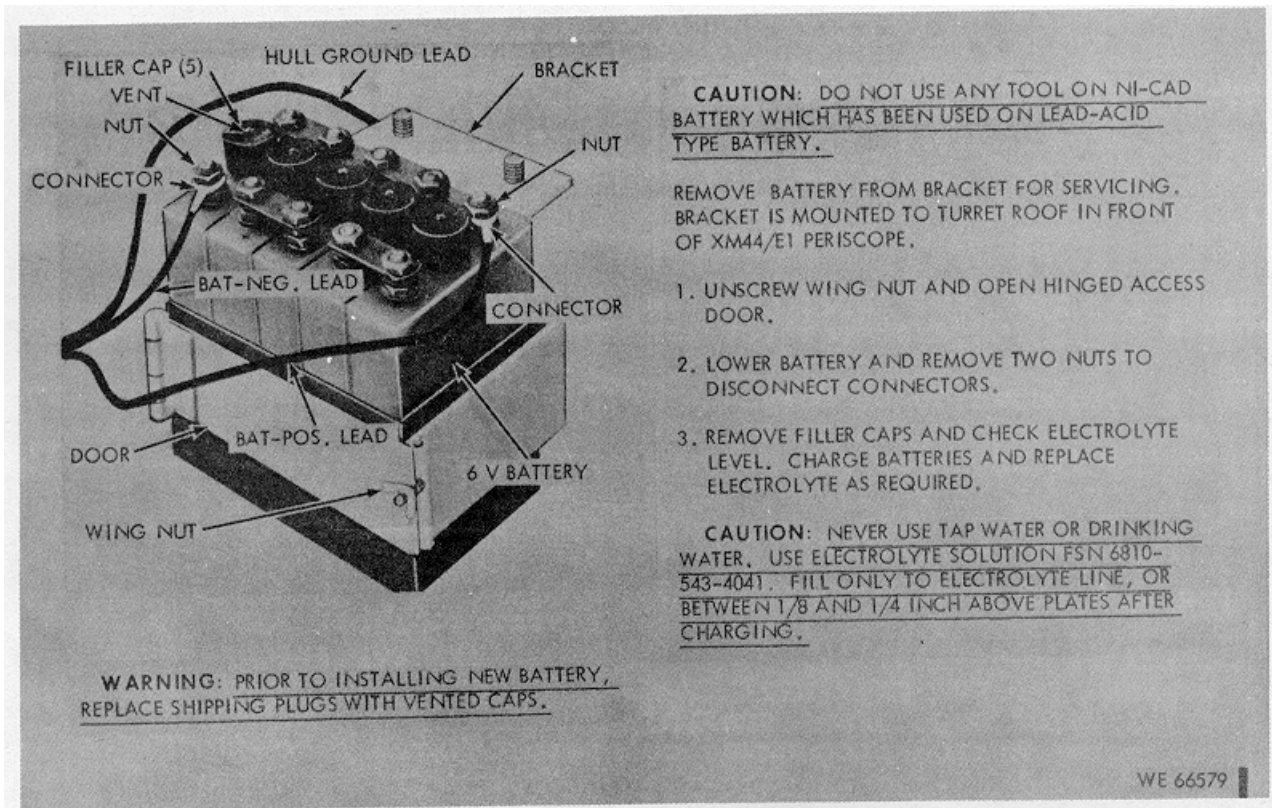
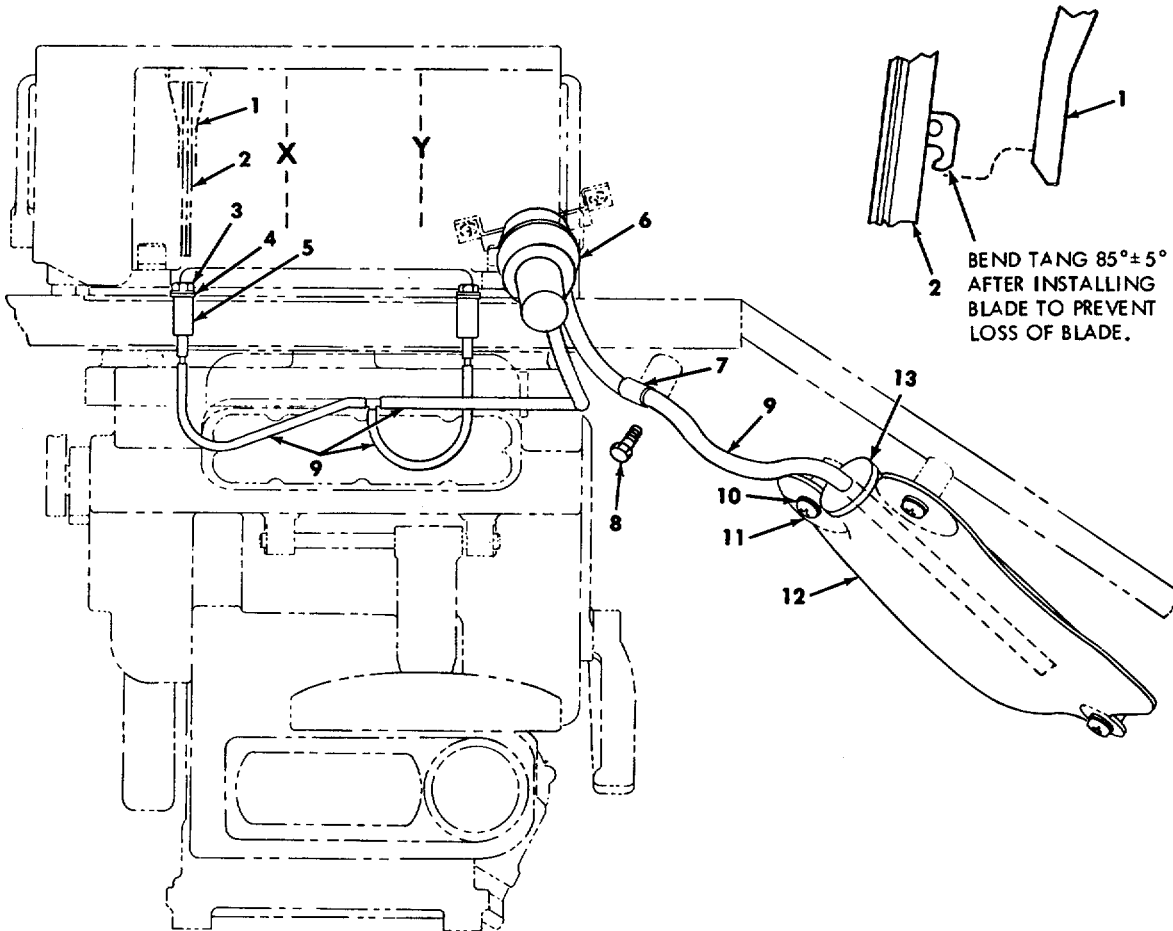

Figure 11-41. 3. Servicing XM44 series periscope emergency battery





**LEGEND**

- |                      |                |
|----------------------|----------------|
| 1. WIPER ARM         | 7. CLAMP (3)   |
| 2. WIPER BLADE       | 8. SCREW (3)   |
| 3. NOZZLE (2)        | 9. TUBING      |
| 4. WASHER (2)        | 10. WASHER (3) |
| 5. WELL NUT (RUBBER) | 11. SCREW (3)  |
| 6. PUMP              | 12. RESERVOIR  |
|                      | 13. STRAINER   |

**REMOVAL AND SERVICING**

REMOVE TUBING AND REPLACE UNSERVICEABLE COMPONENTS.

INSPECT STRAINER WEEKLY AND CLEAN WITH COMPRESSED AIR AS REQUIRED.

USE CARE IN REMOVING AND CLEANING NOZZLES TO PREVENT DAMAGE TO HOLE.

**INSTALLATION**

ADJUST NOZZLES HORIZONTALLY SO THAT SOLVENT IS SPRAYED ON PERISCOPE WINDOWS AT LOCATIONS SHOWN BY X AND Y ON ILLUSTRATION ABOVE.

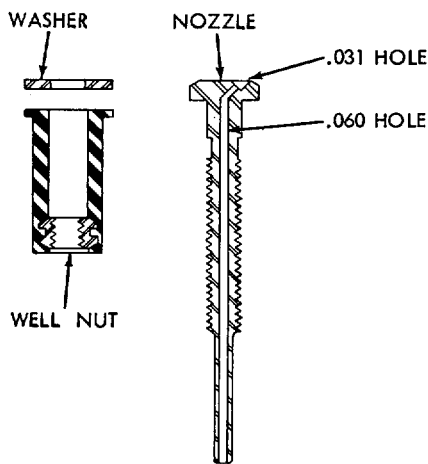

**NOTE.** WHEN REFILLING RESERVOIR USE COMBINATION SOLVENT AND ANTI-ICING FLUID MIL-A-8243.

WE 66639

Figure 11-42. Removal/installation - XM44 Series periscope washer, pump, reservoir, and wiper blade

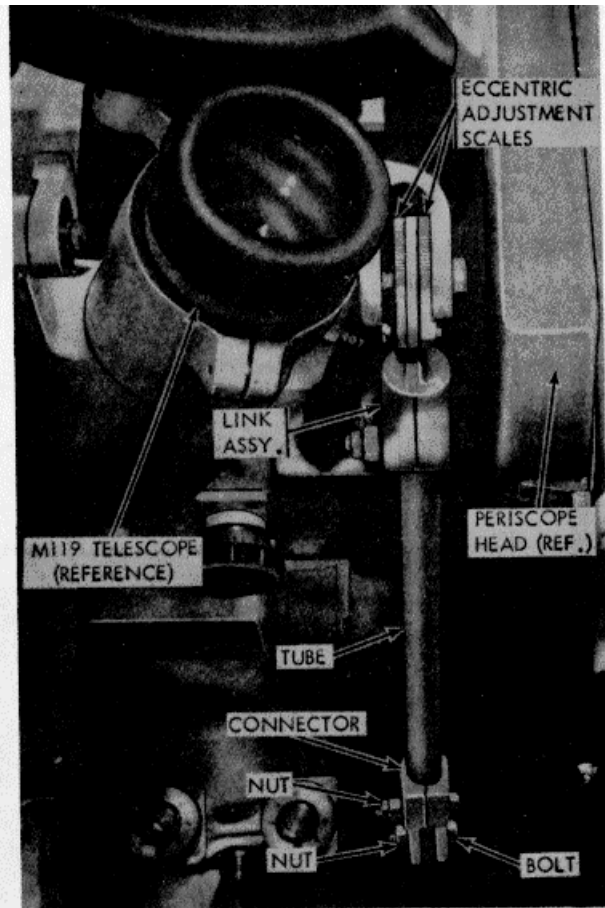
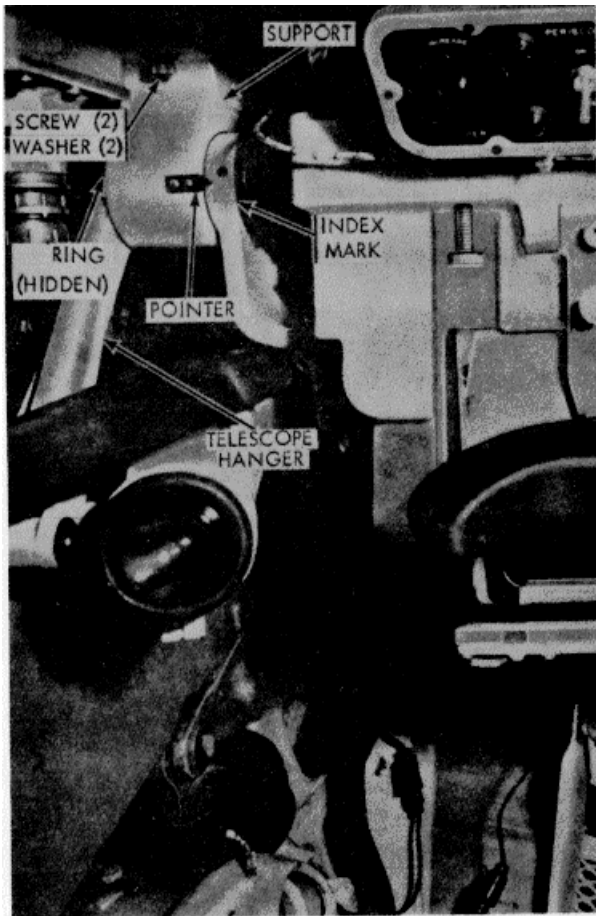

#### REMOVAL

1. REMOVE M119 TELESCOPE AND HANGER, FIG. 11-40.
2. REMOVE PERISCOPE BODY AND HEAD, FIG. 11-41.
3. REMOVE NUT AND BOLT FROM FORWARD END OF LINKAGE CONNECTOR - REPLACE NUT AND BOLT IN CONNECTOR TO PREVENT LOSS.

NOTE. ON LATER VEHICLES WHICH HAVE A QUICK-DISCONNECT CLAMP ASSEMBLY IN PLACE OF THE LINK ASSEMBLY SHOWN, DISCONNECT CLAMP FROM ECCENTRIC AND OMIT STEP 4.

4. HOLD LINKAGE SUPPORT AND REMOVE 2 SCREWS AND WASHER. DO NOT DISTURB LINKAGE ADJUSTMENTS WHILE LINKAGE IS REMOVED FROM TURRET.

#### INSTALLATION

WHEN ORIGINAL LINKAGE IS TO BE INSTALLED AND ADJUSTMENTS HAVE NOT BEEN DISTURBED, INSTALL BY REVERSING REMOVAL PROCEDURE AND CHECK (OR ADJUST) SYNCHRONIZATION OF PERISCOPE IN ACCORDANCE WITH TABLE 11-6.

WHEN A NEW LINK OR LINKAGE SYSTEM IS TO BE INSTALLED, THE FOLLOWING CHECK AND/OR ADJUSTMENT SHOULD BE MADE TO LINK BEFORE INSTALLATION OF PERISCOPE HEAD AND BODY TO PREVENT DAMAGE TO PERISCOPE HEAD INTERNAL LINKAGE.

- A. ADJUST M1A1 GUNNER'S QUADRANT TO ZERO ELEVATION AND PLACE ON MACHINED SURFACE OF TURRET ROOF TO SIDE OF PERISCOPE. QUADRANT IS TO BE IN LINE WITH GUN-LAUNCHER.
- B. ROTATE TURRET UNTIL QUADRANT BUBBLE IS LEVELED.
- C. PLACE QUADRANT ON GUN-LAUNCHER FIG. 2-28 AND ELEVATE OR DEPRESS GUN-LAUNCHER TO ZERO ELEVATION.
- D. LOOSEN CLAMPING NUTS AND ROTATE TUBE UNTIL INDEX MARK IS IN LINE WITH POINTER. TIGHTEN CLAMPING NUTS.

NOTE. STEPS A, B, C, AND D MAY BE OMITTED IF THE LINKAGE ASSEMBLY (LINK ASSEMBLY, TUBE, AND CONNECTOR) IS ADJUSTED TO 23-27/32 INCHES BETWEEN BEARING CENTERS BEFORE INSTALLATION IN TURRET.

- E. INSTALL PERISCOPE AND TELESCOPE, FIG. 11-41 AND FIG. 11-40.
- F. CHECK SYNCHRONIZATION OF PERISCOPE WITH GUN-LAUNCHER IN ACCORDANCE WITH TABLE 11-6. IF NECESSARY, SYNCHRONIZE LINKAGE.

WE 10969A

Figure

11-43. Removal/installation - XM44 Series periscope linkage

## CHAPTER 12 SPECIAL PURPOSE KITS

---

### Section 12-1. GENERAL

#### 12-1. Scope

This chapter illustrates procedures for the installation and allocated maintenance of spe-

cial purpose kits available for application to the M551 vehicles by organizational maintenance personnel.

Sections 12-2 and 12-3 including paragraphs 12-2 and 12-3 - deleted.

### Section 12-4. ENGINE AND BATTERY WINTERIZATION KIT

#### 12-4. General

a. The winterization kit, when installed, provides a standby coolant heating and circulating system for use during shutdown periods at ambient temperatures between -25sF and -65 F. The coolant heater system serves the dual purpose of preventing freezing of battery electrolyte, and of keeping the engine sufficiently warm to aid in starting.

b. The system is electrically actuated from a control box located to the left of the driver. An electric fuel pump delivers fuel from the vehicle center fuel supply tank into the coolant heater where it is ignited in a combustion chamber. Coolant is circulated through the

heater, engine, and battery heater by an electrically driven coolant pump furnished with the kit.

c. Operating procedures are covered in Table 2-13. Troubleshooting procedures are listed in Table 8-4, items 60 through 66.

d. Original installation of the kit is performed by support maintenance personnel.

e. Removal, replacement and maintenance of components of the kit are illustrated in figures 12-5 through 12-12.

### Section 12-5. LESS MISSILE SYSTEM KIT

#### 12-5. General

a. The less missile system kit provides for the removal of a portion of the missile subsystem from vehicles when assigned to specific fielding not requiring a missile subsystem. Production vehicles, serial No. 140 through 223 and 740 through 885 were manufactured less missile subsystem.

b. Additional components of the kit are installed to provide turret and weapon stabilization utilizing missile subsystem power supply and rate sensor. Additional ammunition stowage is also provided when kit is installed (Fig. 12-13).

### Section 12-6. MINE PROTECTIVE KIT

#### 12-6. General

a. The mine protective kit consists of an armor steel plate and aluminum spacer plate for the hull bottom, two armor steel side plates, and attaching hardware. Because of hull modification required to accept the kit, original

installation is made by support maintenance personnel.

b. Removal of the kit is shown in figures 12-14 and 12-15.

Section 12-7 and figures 12-1, 12-2, 12-3, 12-4, 12-4. 1, and 12-4. 2 - deleted.

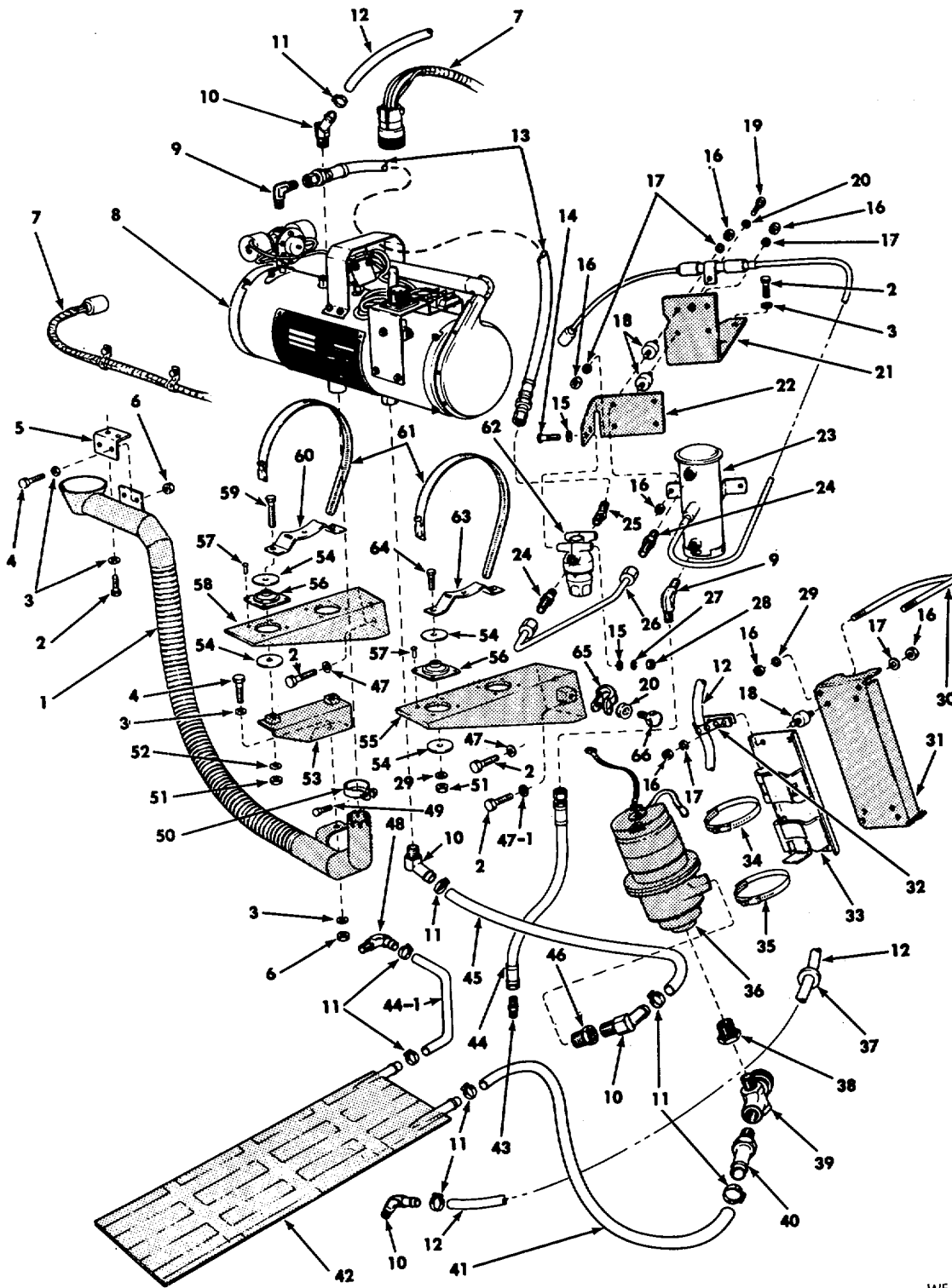

WE 19767

Figure 12-5. Removal/installation - vehicle winterization kit.

Pages 12-2.1 thru 12-6. 2 deleted.

**TABLE 12-1. REMOVAL/INSTALLATION--VEHICLE WINTERIZATION KIT COMPONENTS  
(Refer to Figure 12-5)**

Turn heater power supply off at control box in driver's compartment (Figure 12-8).	
COMPONENT LEGEND	
<ol style="list-style-type: none"> <li>1. EXHAUST PIPE ASSEMBLY</li> <li>2. SCREW-MS90728-59</li> <li>3. WASHER - 10910174-3</li> <li>4. SCREW - MS90727-59</li> <li>5. ROOF BRACKET</li> <li>6. NUT - MS51968-9</li> <li>7. WIRING HARNESS - COOLANT HEATER - TO-ENGINE COMPARTMENT BULKHEAD]</li> <li>8. COOLANT HEATER</li> <li>9. ELBOW- MS20822-4</li> <li>10. ELBOW - MS24518-7</li> <li>11. HOSE CLAMP - MS35842-11</li> <li>12. COOLANT HEATER-TO-ENGINE HOSE (52-INCHES LONG)</li> <li>13. HEATER FUEL INLET HOSE</li> <li>14. SCREW - MS35207-270</li> <li>15. WASHER - 27183-8</li> <li>16. NUT - MS51967-3</li> <li>17. WASHER - MS27183-10</li> <li>18. SHOCK MOUNT</li> <li>19. SCREW - MS90728-5</li> <li>20. WASHER,- MS35334-19</li> <li>21. FUEL PUMP MOUNTING BRACKET</li> <li>22. FUEL FILTER MOUNTING BRACKET</li> <li>23. ELECTRIC FUEL PUMP</li> <li>24. ADAPTER - MS39206-3</li> <li>25. ELBOW- MS20823-4</li> <li>26. FUEL PUMP OUTLET TUBE</li> <li>27. WASHER - MS35338-43</li> <li>28. NUT - MS35650-302</li> <li>29. WASHER- 10910174-1</li> <li>30. U-BOLT - 11619028</li> <li>31. PUMP MOUNTING PLATF</li> <li>32. STRAP</li> <li>33. PUMP MOUNTING BRACKET</li> <li>34. CLAMP - MS35842-15</li> </ol>	<ol style="list-style-type: none"> <li>35. CLAMP - MS35842-14</li> <li>36. COOLANT PUMP</li> <li>37. COOLING FAN LOWER RIGHT SHROUD GROMMET</li> <li>38. BUSHING - AN912-85</li> <li>39. THERMOSTAT - 7700453-1</li> <li>40. ADAPTER - MS24522-23</li> <li>41. BATTERY HEATER-TO-COOLANT PUMP HOSE (24 INCHES LONG)</li> <li>42. BATTERY HEATER</li> <li>43. NIPPLE - AN816-4-4</li> <li>44. FUEL PUMP INLET HOSE</li> <li>44-1. BATTERY HEATER INLET HOSE</li> <li>45. COOLANT HEATER INLET HOSE (25 INCHES LONG)</li> <li>46. BUSHING - AN912-75</li> <li>47. WASHER - 10941915-3</li> <li>47-1. WASHER - MS35334-2 (BOTTOM SCREW RIGHT BRACKET)</li> <li>48. ELBOW - MS24519-7</li> <li>49. SCREW - MS90721-61</li> <li>50. EXHAUST PIPE CLAMP</li> <li>51. NUT - MS51968-3</li> <li>52. WASHER - 1091017-1</li> <li>53. EXHAUST PIPE BRACKET</li> <li>54. SNUBBING WASHER - AN8013-D2</li> <li>55. HEATER RIGHT BRACKET</li> <li>56. SHOCK MOUNT</li> <li>57. RIVET</li> <li>58. HEATER LEFT BRACKET</li> <li>59. SCREW - MS90727-13</li> <li>60. LEFT CRADLE BRACKET</li> <li>61. MOUNTING CLAMP - MS35842-16</li> <li>62. FUEL FILTER</li> <li>63. RIGHT CRADLE BRACKET</li> <li>64. SCREW - MS90727-10</li> <li>65. CLAMP - 7997714</li> <li>66. SCREW - MS90728-3</li> </ol>

**REMOVAL OF SPECIFIC COMPONENTS**

Item No.	Procedure
8	<p><u>NOTE.</u> When component removal involves breaking coolant circuit it is recommended that vehicle coolant system be drained first.</p> <p>COOLANT HEATER: Shut off fuel supply (valve is located just below adapter, item 43). Disconnect fuel line (13) at elbow (9). Disconnect wiring harness (7) at heater receptacle. Loosen clamp (11) and disconnect outlet hose (12). Loosen clamp (11) and disconnect heater inlet hose at coolant pump. Loosen clamp (50) and disconnect exhaust pipe assembly (1). Remove two mounting clamps (61) and remove coolant heater.</p>

Table 12-1. Removal/Installation - Vehicle Winterization Kit Components - Continued

- 23 FUEL PUMP: Shut off fuel supply (valve is located just below adapter, item 43). Disconnect fuel pump outlet tube (26) from adapter (24) at fuel pump. Disconnect fuel pump inlet hose (44) from elbow (9). Disconnect power lead from harness (7) and remove screw (19) and washer (20). Remove two nuts (16) holding pump to bracket, and remove fuel pump assembly.
- 36 COOLANT PUMP: Disconnect power lead from harness (7) and disconnect ground lead at fuel pump bracket. Loosen clamps (11), and disconnect inlet (41) and outlet (45) hoses. Remove two clamps (34 and 35) and remove coolant pump.
- 42 BATTERY HEATER: Disconnect and remove batteries (figure 9-97). Loosen two clamps (11) and disconnect inlet (44-1) and outlet (41) hoses. Remove heater tray.
- 56 SHOCK MOUNTS: Remove coolant heater (item no. 8 above). Remove two screws (2) and washers (47, 47-1) to remove each heater bracket (55 and 58). On right bracket, also remove screw (66), washer (20) and harness clamp. Remove nuts (51) washers (29, 52) screws (59, 64), exhaust pipe bracket (53, left bracket only), snubbing washers (54) and 'cradles (60, 63). Drill or punch out rivets (57) to remove shock mounts.
- 62 FUEL FILTER: Shut off fuel supply (valve is located just below adapter, item 43). Refer to figure 9-134 for filter service. OTHER COMPONENTS: Replace unserviceable components as required.

### INSTALLATION

Reverse removal procedure.

Whenever coolant lines have been disconnected it is necessary to bleed air from the system as follows:

Disconnect coolant heater outlet hose (12) at elbow (10). Add coolant at surge tank until coolant spills from both elbow and hose. Reinstall hose on elbow without allowing air to enter either hose or elbow. Tighten clamp and continue adding coolant until full level is reached in surge tank.

After engine has been run to raise coolant pressure in system make visual check of all hose connections for leaks.

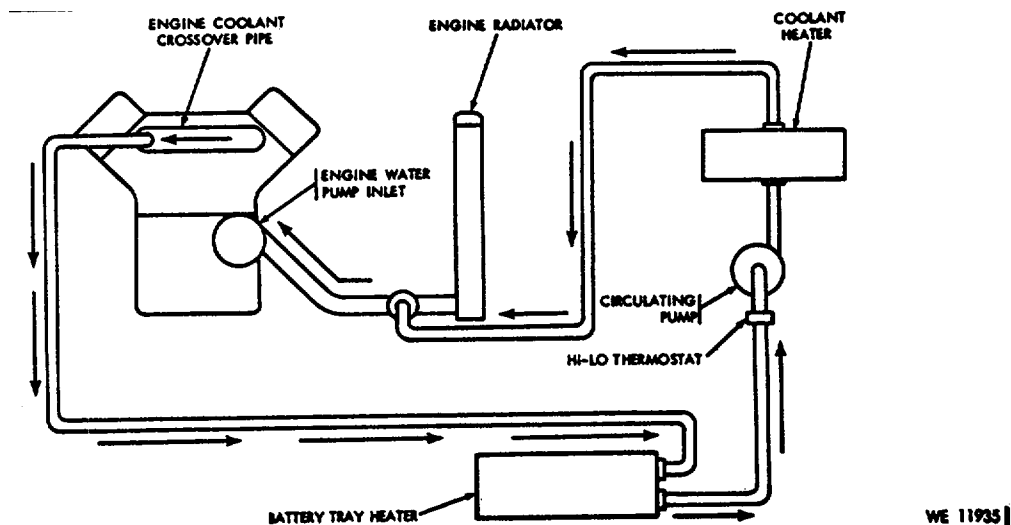

Figure 12-6. (Added) Winterization kit coolant flow diagram.

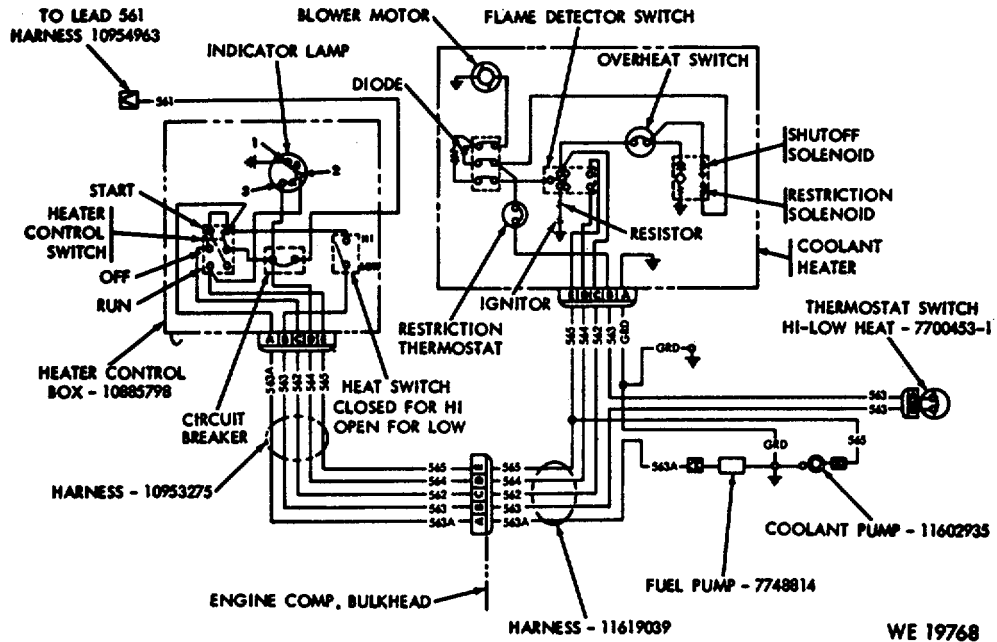
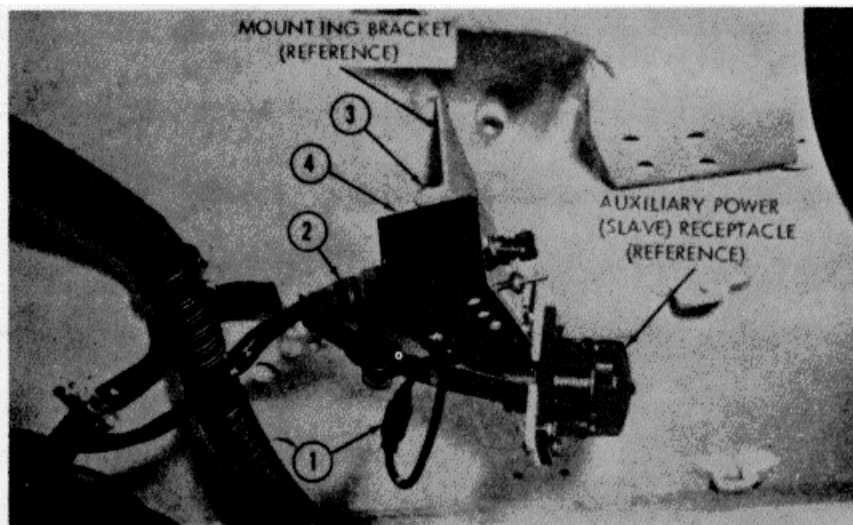

Figure 12-7. (Added) Winterization kit wiring diagram.



**PRELIMINARY STEP**

DISCONNECT BATTERY GROUND CABLE.

**REMOVAL**

1. DISCONNECT POWER LEAD (CIRCUIT NO. 561) FROM CONTROL BOX.
2. DISCONNECT CONTROL BOX-TO-BULKHEAD WIRING HARNESS.

3. REMOVE 2 NUTS AND WASHERS.
4. REMOVE CONTROL BOX.

REFER TO FIGURE 12-9 FOR REPAIR INFORMATION.

**INSTALLATION**

REVERSE REMOVAL PROCEDURE.

WE 11939

Figure 12-8. (Added) Removal/installation - winterization kit control box.

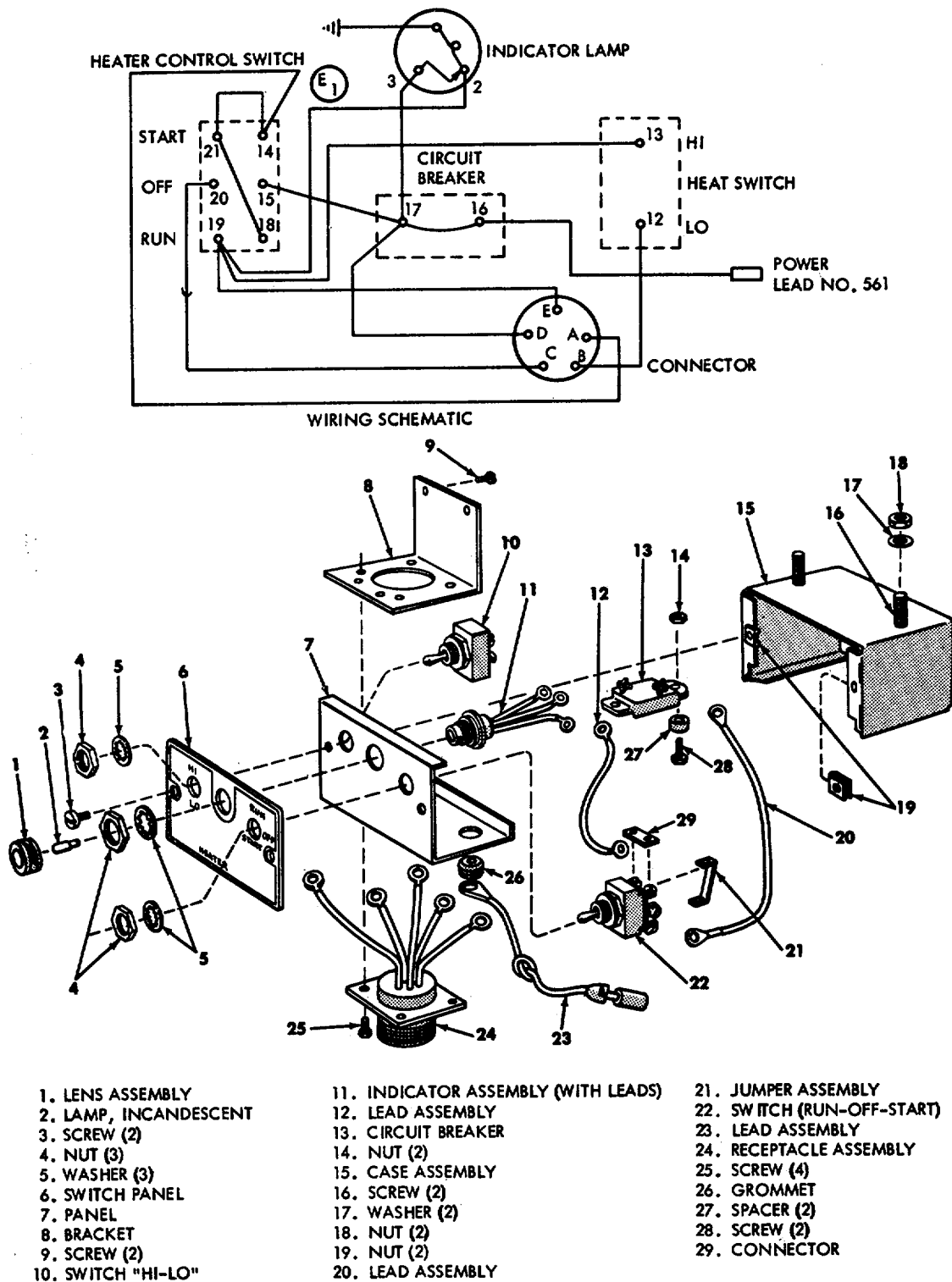

REPLACE UNSERVICABLE COMPONENTS AS REQUIRED.

WE 11938

Figure 12-9. (Added) Repair - winterization kit control box.



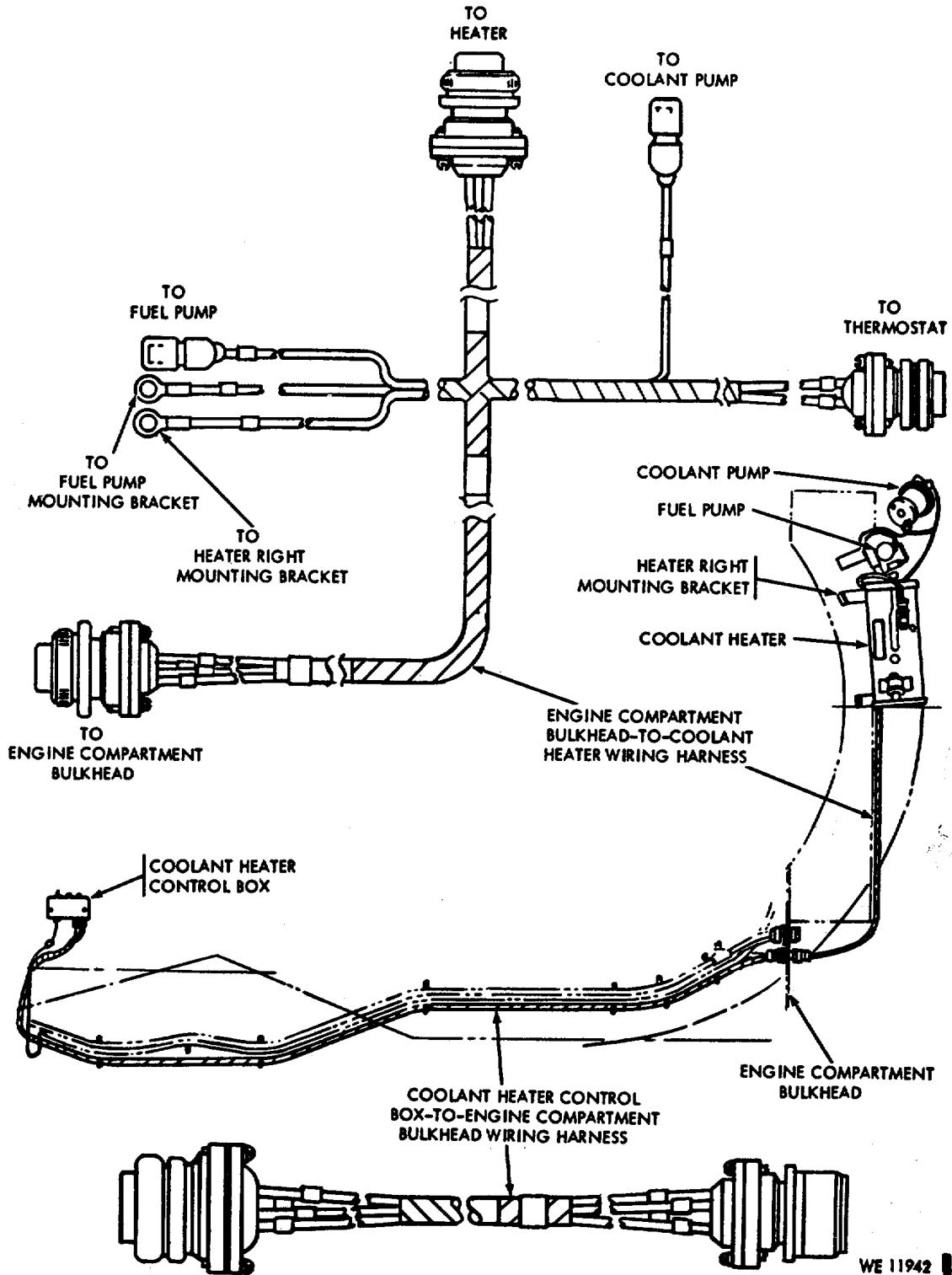

WE 11942

Figure 12-10. (Added) Coolant heater wiring harness

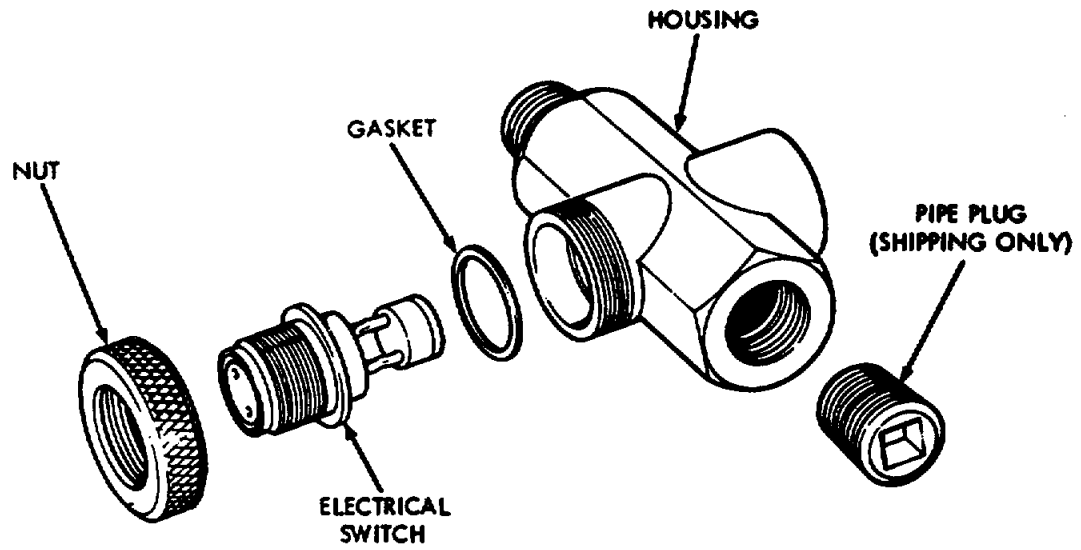

**NOTE. SWITCH CONTACTS OPEN AT 155° TO 165° F.  
AND CLOSE AT 115° TO 125° F.**

**WE 11943** 

*Figure 12-11. (Added) Disassembly/assembly - winterization kit coolant heater thermostat*

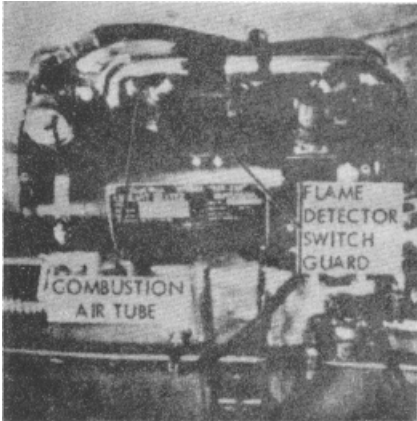

A. COOLANT HEATER INSTALLED

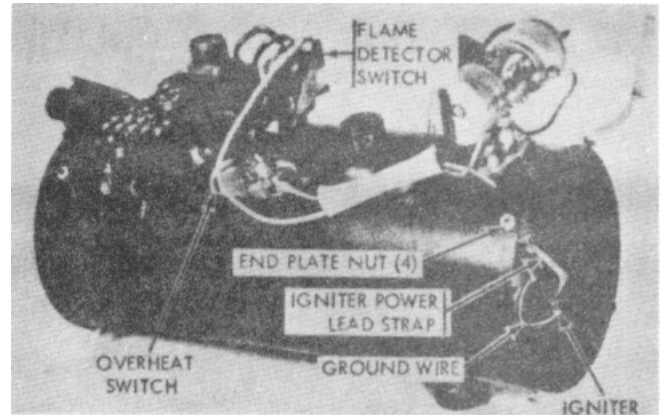

B. COOLANT HEATER SWITCH GUARD AND AIR TUBE REMOVED,.

**FLAME DETECTOR SWITCH ASSEMBLY REMOVAL**

1. REMOVE 4 SCREWS AND FLAME DETECTOR SWITCH GUARD.
2. REMOVE 1 NUT, GROUND WIRE AND WASHER, AND REMOVE COMBUSTION AIR TUBE.
3. DISCONNECT 5 WIRES FROM FLAME DETECTOR MICROSWITCH. INSTALL SCREWS IN MICROSWITCH TERMINALS.
4. USE 1/2" OPEN END WRENCH TO LOOSEN COMPRESSION NUT UNDER FLAME DETECTOR SWITCH.
5. LIFT SWITCH ASSEMBLY STRAIGHT OUT OF BUSHING TO AVOID BENDING TUBE AND BREAKING CERAMIC ROD.

ADJUSTING FLAME DETECTOR SWITCH  
REFER TO FIGURE 9-137.

**IGNITER REMOVAL**

1. REMOVE END PLATE FROM HEATER BY LOOSENING 4 NUTS AND TURNING PLATE COUNTERCLOCKWISE.
2. DISCONNECT IGNITER POWER LEAD STRAP.
3. DISCONNECT IGNITER GROUND WIRE AND BEND THE WIRE SO IT WILL FIT INSIDE A DEEP SOCKET.
4. USE 13/16 DEEP SOCKET TO REMOVE IGNITER. USE CARE TO AVOID DAMAGE TO IGNITER FILAMENT.

**OVERHEAT SWITCH REMOVAL**

1. REMOVE 4 SCREWS AND FLAME DETECTOR SWITCH GUARD.
2. DISCONNECT 4 ELECTRICAL LEADS FROM OVERHEAT SWITCH TERMINALS.
3. REMOVE SCREW AND LOCK WASHER FROM CENTER OF OVERHEAT SWITCH COVER TO REMOVE COVER.
4. LIFT SWITCH OFF HEAT EXCHANGER.

**INSTALLATION**

REVERSE REMOVAL PROCEDURE, REPLACING UNSERVICEABLE COMPONENTS AS REQUIRED. CONNECT WIRING AS SHOWN ON WIRING DIAGRAM, FIGURE 12-7. WHEN REPLACING FLAME DETECTOR SWITCH ASSEMBLY, RETURN OLD SWITCH ASSEMBLY TO SUPPORT MAINTENANCE FOR REPAIR AND RETURN TO STOCK.

WE 11953

Figure 12-12. (Added) Removal/installation - Coolant heater igniter, overheat switch, and flame detector switch

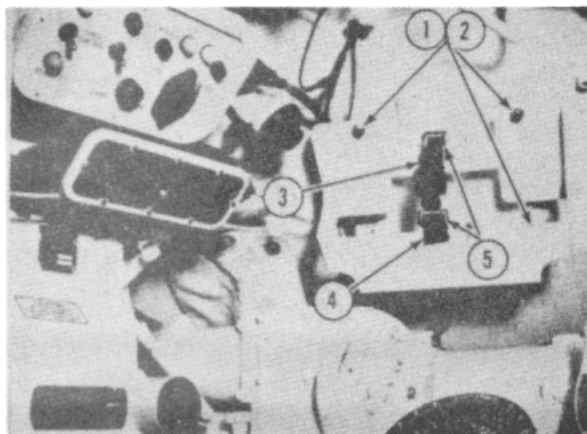

A. BRACKET ASSY, 11619526

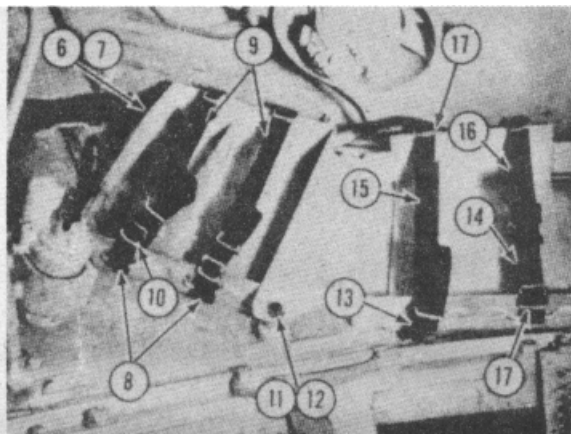

B & C. BRACKET ASSY'S 11619527 & 11619529

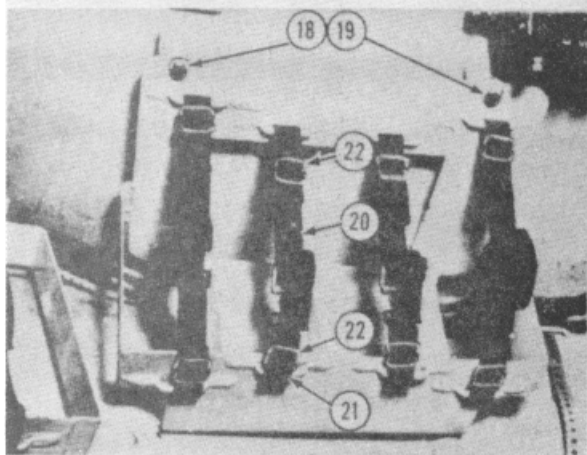

D. BRACKET ASSY, 11619528

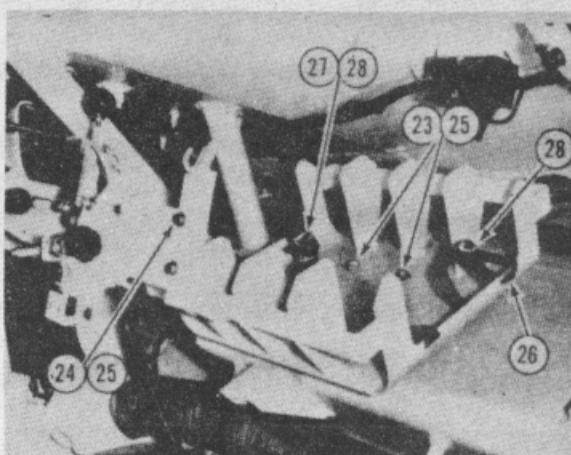

E. BRACKET ASSY, 11619530

A. AMMUNITION BOX STOWAGE BRACKET ASSY. 11619526 . .

- |                |                 |
|----------------|-----------------|
| 1. SCREWS (4)  | (5306-050-1238) |
| 2. WASHERS (4) | (5306-050-1238) |
| 3. STRAP       | (2590-918-6190) |
| 4. STRAP       | (2540-874-6727) |
| 5. SLIDE(2)    | (5340-999-4286) |

B. AMMUNITION BOX STOWAGE BRACKET ASSY. 11619527

- |                |                 |
|----------------|-----------------|
| 6. SCREWS (2)  | (5305-269-3234) |
| 7. WASHERS (2) | (5310-877-5972) |
| 8. STRAPS (2)  | (2590-918-6191) |
| 9. STRAPS(2)   | (2540-886-1183) |
| 10. SLIDES (4) | (5340-999-4286) |

C. AMMUNITION BOX STOWAGE BRACKET ASSY. 11619529

- |                 |                 |
|-----------------|-----------------|
| 11. SCREWS (2)  | (5305-269-3235) |
| 12. WASHERS (2) | (5310-877-5972) |
| 13. STRAP       | (2590-918-6190) |
| 14. STRAP       | (2590-945-8804) |
| 15. STRAP       | (2540-874-6728) |
| 16. STRAP       | (2540-874-6730) |
| 17. SLIDES (4)  | (5340-999-4286) |

D. AMMUNITION BOX STOWAGE BRACKET ASSY. 11619528

- |                 |                 |
|-----------------|-----------------|
| 18. SCREWS (4)  | (5305-269-3234) |
| 19. WASHERS (4) | (5310-877-5972) |
| 20. STRAPS (4)  | (2590-945-8804) |
| 21. STRAPS (4)  | (2540-874-6727) |
| 22. SLIDES (8)  | (5340-999-4286) |

E. GRENADE PROJECTOR STOWAGE BRACKET ASSY.11619530

- |                 |                 |
|-----------------|-----------------|
| 23. SCREWS(4)   | (5305-068-0510) |
| 24. SCREWS (2)  | 5305-558-4181)  |
| 25. WASHERS (6) | (5310-877-5972) |
| 26. STRAPS(2)   | (2590-945-8799) |
| 27. STRAPS (2)  | (2540-874-6730) |
| 28. SLIDES (4)  | (5340-999-4286) |

REMOVAL/INSTALLATION

REPLACE UNSERVICEABLE COMPONENTS AS REQUIRED

Figure 12-13. (Added) Ammunition stowage added to vehicles without missile subsystem

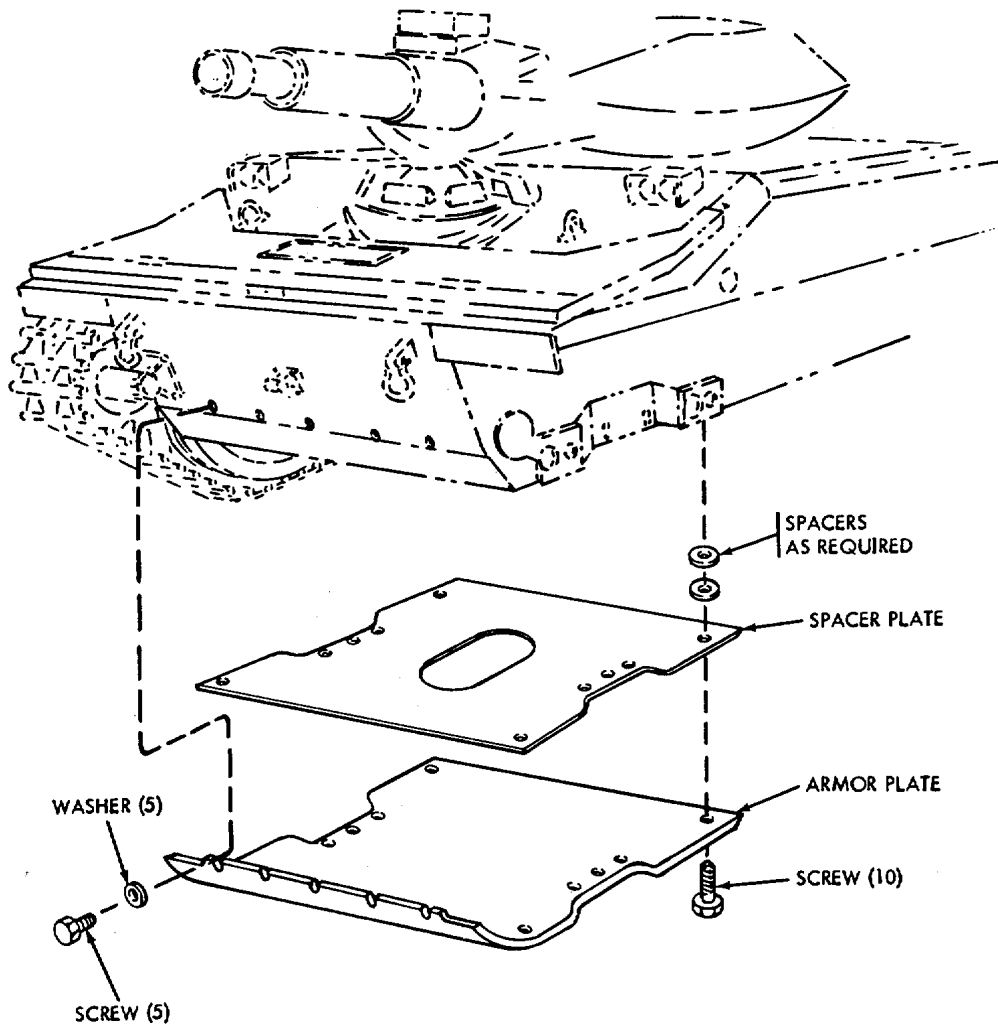

**WARNING:** MAKE SURE PLATES ARE ADEQUATELY SUPPORTED DURING REMOVAL. USE SUITABLE LIFTING EQUIPMENT TO HANDLE PLATES AFTER REMOVAL.

1. PLACE FOUR JACKS UNDER KIT PLATES TO SUPPORT PLATES WHILE REMOVING SCREWS.
2. REMOVE 5 SCREWS FROM EACH SIDE AND 5 SCREWS AND WASHERS FROM FRONT EDGE OF PLATE.
3. LOWER JACKS UNTIL PLATES CLEAR VEHICLE SHOCK ABSORBERS.
4. BACK VEHICLE OFF PLATES.
5. INSTALL 15 SCREWS MS90728-183 WITH WASHERS 10910174-8 TO PLUG HOLES IN VEHICLE HULL (SCREWS AND WASHERS ARE FURNISHED AS PART OF KIT).

WE 66642

Figure 12-14. Removal - mine protective kit (1 of 2)

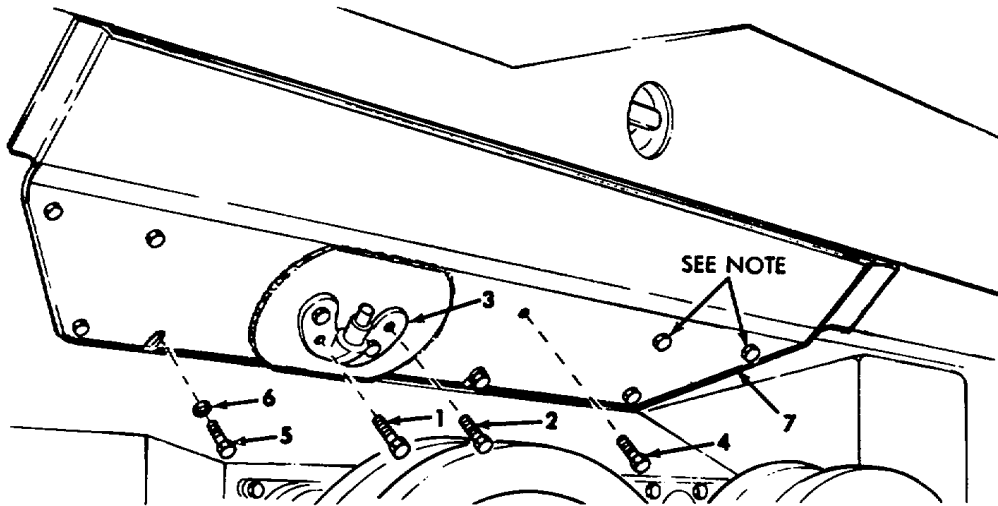
**LEGEND**

1. SCREW (2)
2. SCREW (2)
3. SHOCK ABSORBER MOUNTING BRACKET
4. SCREW (7 LEFT SIDE, 8 RIGHT)
5. SCREW (2)
6. WASHER (2)
7. PLATE (LEFT SHOWN, RIGHT SIMILAR)

**PRELIMINARY STEP**

DISCONNECT TRACK (FIG. 5-5) AND ROLL VEHICLE BACKWARD UNTIL TOPS OF FIRST 3 ROAD WHEELS ARE FREE OF TRACK.  
DISCONNECT FRONT SHOCK ABSORBER FROM MOUNTING BRACKET (FIG. 9-74).

**REMOVAL**

1. FOLLOW LEGEND THROUGH ITEM 4.
2. LOOSEN 2 SCREWS (5) AND USE CRANE OR JACK TO REMOVE PLATE (WEIGHT IS APPROXIMATELY 250 POUNDS).

3. INSTALL SHOCK ABSORBER MOUNTING BRACKET USING TWO SCREWS MS90727-187 (2" LONG) IN TOP HOLES AND TWO SCREWS MS90727-188 (2-1/4" LONG) IN BOTTOM HOLES. TIGHTEN TO 290-350 POUND-FEET.
4. INSTALL SHOCK ABSORBER ON MOUNTING BRACKET.
5. USE SCREWS (ITEMS 4 AND 5) TO PLUG HOLES IN HULL.

**NOTE.** WHEN LEFT SIDE PLATE IS REMOVED 2 SHORTER SCREWS (FSN 5305-732-0512) SHOULD BE USED TO AVOID INTERFERENCE WHEN PLUGGING THE TWO UPPER REAR HOLES.

WE 66660

Figure 12-15. Removal - mine protective kit (2 of 2).

Pages 12-17 and 12-18, including figure 12-16-deleted.

**CHAPTER 13  
DESCRIPTION, OPERATION AND MAINTENANCE  
OF 7.62MM MACHINE GUN M73E1**

**Section 13-1. DESCRIPTION AND DATA**

**13-1. General**

The M73E1 machine gun is interchangeable with previous model M73 for coaxial application on the M551 vehicle. The redesign results in an increase in the cyclical rate of fire as reflected in tabulated data below. There is no change in controls, operation, or operator/crew maintenance. All material in this manual pertaining to 7.62MM machine gun is equally applicable to the M73 and M73E1 except where otherwise specified.

**13-2. Description**

The 7.62MM machine gun M73E1 (fig. 5-11) is a lightweight, air-cooled, metallic link belt fed weapon. It has a short receiver, is recoil operated with a gas assist to boost recoil, and designed with a quick change barrel with fixed -Headspace. The cycle of operation and functioning is initiated from the retracted position of the barrel extension assembly. Major groups and assemblies are illustrated in figure 13-1 and described in table 13-1.

**13-3. Tabulated Data - M73E1 Only**

Weight of gun.....	31.00 lbs.
Weight of barrel.....	5.25 lbs.
Length of gun.....	35.00 in.
Length of barrel.....	22.00 in.
Number of grooves.....	4
Twist, right hand.....	one turn in 12 in.
Height cover closed.....	5.30 in.
Height cover opened.....	6.60 in.
Width.....	4.40 in.
Feed.....	metallic link belt
Operation.....	Recoil with gas assist
Cooling.....	Air
Muzzle velocity.....	2,800 fps (approx)
Rate of fire (cyclic).....	500 to 600 rd per min
Maximum range.....	See appropriate F. T. (approx) (3,700 meters or 4,150 yds)
Maximum effective range.....	900 meters (tracer burnout point)
Method of target engagement.....	20-30 round bursts

*Table 13-1. Major Groups and Assemblies - M73E1 (Fig. 13-1)*

ASSEMBLY OR GROUP	DESCRIPTION
Jacket assembly group	(Items 1 through 4) Secured to front portion of the receiver assembly (trunnion block). Designed for quick removal. Consists of jacket assembly, with bearing lock and barrel assembly.
Cover assembly	(Item 5) Located on top of the receiver assembly over the feed tray group. Secured to receiver by the right and left latch rod assemblies. It feeds the belt and positions and holds the cartridges for chambering. The feed mechanism is actuated by a stud on the barrel extension, which engages the feed cam.
Feed tray group	(Item 6) Located on top of receiver assembly under the cover assembly. It is composed of the cartridge stop assembly and the feed tray assembly. The feed tray group serves as a guide for the belt to assist in positioning the cartridges and provides directional control for link ejection.

Table 13-1. Major Groups and Assemblies - M73E1 (Fig. 13-1) - Continued

ASSEMBLY OR GROUP	DESCRIPTION
Back plate assembly, helical (driving) springs and guide rod group	(Items 7 through 10) Helical (driving) springs are located at rear of the barrel extension assembly. They are retained in position by the guide rods, which are secured to the back plate. They help absorb recoil shock and provide the energy to feed, strip, chamber, and fire the following round. The back plate assembly is located at the rear portion of the receiver assembly. It houses the trigger sear and solenoid. The trigger safety is located at the top of the back plate. It acts as a positive sear block for manual operation of the trigger and when the weapon is operated by the solenoid. It contains a nut shield covering the nuts securing solenoid to back plate.
Barrel extension group	(Items 11 through 13) The action group of the weapon. Composed of the breechblock assembly and barrel extension assembly. This group chambers and fires the cartridge, locks and unlocks the breech, and extracts and ejects the spent cartridge cases.
Charger group	(Items 14 through 17) Composed of a retaining ring and charger assembly. The retaining ring secures the charger assembly to the receiver. The charger assembly may be assembled on the right or left side of the receiver by repositioning the slide connector, buffer pivot pin, and charger mounting stud. The charger is utilized to manually charge the weapon (before loading), loading the first round, and to recharge the weapon in case of a malfunction or stoppage.
Receiver assembly	(Item 18) Serves as a support for all major assemblies and groups. It houses the action of the weapon and, through a series of cam ways, controls the functioning of the barrel extension assembly and breechblock assembly.
<p><b>NOTE</b></p> <p><b>The serial number is located on the left side of the receiver.</b></p> <p><b>Section 13-2. OPERATING INSTRUCTIONS</b></p>	

**13-4. Service Upon Receipt of Materiel** Refer to table 2-1. Refer to figure 5-13 for installation of flash hider

**13-5. Instruments and Controls** a. Instruments MI119 telescope and XM44E1 periscope are used for aiming the

7.62MM coaxial machine gun as well as the 152MM gun/launcher (figure 2-23).

b. Controls. For description, illustration and function of controls refer to table 13-2.

**13-6. Operation**

For preparation, loading and firing procedures refer to Chapter 3.



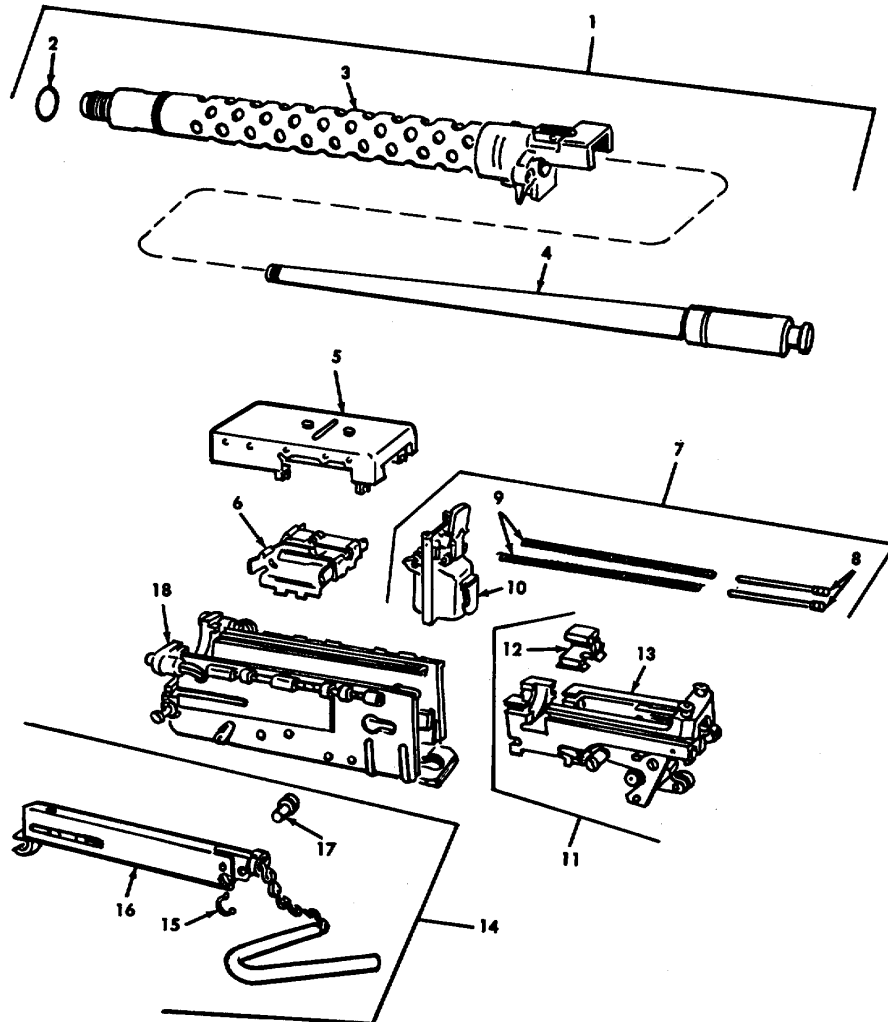

- |   |   |
|---|---|
| <ul style="list-style-type: none"> <li>1. JACKET ASSEMBLY GROUP</li> <li>2. BARREL BEARING LOCK</li> <li>3. JACKET ASSEMBLY WITH BEARING</li> <li>4. BARREL ASSEMBLY</li> <li>5. COVER ASSEMBLY</li> <li>6. FEED TRAY GROUP</li> <li>7. BACK PLATE ASSEMBLY, HELICAL SPRING AND GUIDE ROD GROUP</li> <li>8. GUIDE ROD ASSEMBLY</li> <li>9. COMPRESSION HELICAL SPRING (DRIVING SPRING)</li> </ul> | <ul style="list-style-type: none"> <li>10. BACK PLATE ASSEMBLY WITH SOLENOID</li> <li>11. BARREL EXTENSION GROUP *</li> <li>12. BREECHBLOCK ASSEMBLY</li> <li>13. BARREL EXTENSION ASSEMBLY</li> <li>14. CHARGER GROUP</li> <li>15. RETAINING RING</li> <li>16. CHARGER ASSEMBLY</li> <li>17. CHARGER MOUNTING STUD *</li> <li>18. RECEIVER ASSEMBLY</li> </ul> |
|---|---|

\* ITEMS 11 AND 17 ARE NOT INTERCHANGEABLE BETWEEN M73 AND M73E1 MACHINE GUNS.

WE 12042

Figure 13-1. Major groups and assemblies.

Table 13-2. Controls

CONTROL	FUNCTION	REFERENCE
Charger assembly	Retracts barrel extension assembly	Fig. 5-11
Disconnecter pull ring	Retains barrel jacket assembly on receiver	Fig. 5-11. 1
Manual firing trigger	Manually fires weapon	Fig. 5-11
Trigger safety	Prevents accidental firing of machine gun	Fig. 5-11
Cover latch rod assemblies	Holds cover and feed tray in closed latch position	Fig. 5-11. 2
Cover latch rod lock	Retains cover on receiver	Fig. 5-11. 2
Left- or right-hand buffer support lever	Actuates buffer support	Fig. 5-12
Gun and turret control selector	Controls electrical power supply to gun solenoid	Fig. 2-19
Gunner's power control handle	Controls elevation and traverse, and electrical firing	Fig. 2-19
Commander's power control handle	Controls elevation and traverse, and electrical firing	Fig. 2-19
Firing button (on manual elevation handwheel)	Fires gun electrically	Fig. 2-19

### Section 13-3. MAINTENANCE INSTRUCTIONS

#### 13-7. Cleaning Inspection and Lubrication

Refer to table 13-3, table 13-4, and LO 9-2350-230-12

#### 13-8. Preventive Maintenance Checks and Services

Refer to table 4-1

#### 13-9. Troubleshooting

Refer to table 5-1

#### 13-10. Maintenance

a. Disassembly/Assembly. Refer to table 5-9

b. Replacement of Parts. Crew/operator is authorized to replace the following parts when unserviceable:

Barrel assembly (fig. 13-1, item 1)  
Helical compression springs (driving springs) (fig. 13-1, item 9)

Breechblock assembly (fig. 13-1, item 12)  
Barrel extension assembly (fig. 13-1, item 11)

**WARNING: M73 and M73E1 barrel extension assemblies are not interchangeable. Use only assembly (11013360) FSN 1005-937-8256 on M73. Use only assembly (11013432) FSN 1005-832-9612 on M73E1.**

If further replacement of parts is required notify organizational maintenance.

Table 13-3. Specific Lubrication Instructions

STEP	PROCEDURE
1	<p style="text-align: center;">USUAL CONDITIONS 7.62MM MACHINE GUN M73E1</p> <p>Immediately after firing, clean all powder fouled surfaces with (CR) rifle bore cleaning compound.</p> <p><b>CAUTION Do not use rifle bore cleaning compound to clean back plate assembly. Use clean cloths to remove foreign matter. Do not lubricate the back plate assembly due to danger of contamination of the solenoid.</b></p>
2	<p style="text-align: center;"><b>MAJOR GROUPS AND ASSEMBLIES</b></p> <p>Disassemble machine gun into its major groups and assemblies, table 5-9.</p>
3	Clean the components with SD, dry cleaning solvent.
4	Wipe dry and oil with PL special, general purpose lubricating oil, above 0° For LAW, weapons lubricating oil, below 0° F
5	Thereafter, clean and oil as above every 90 days unless inspection reveals shorter intervals are required.
6	Assemble the major groups and assemblies, table 5-9.
7	Remove oil from barrel bore before firing.
8	<p style="text-align: center;"><b>APPLICATION OF SEMI-FLUID LUBRICATING OIL (LSA)</b></p> <p>Semi-fluid lubricating oil is an all purpose lubricant which may be applied in all temperature ranges. This lubricant should be applied before the weapon is fired.</p> <p>Disassemble gun into major groups and assemblies, table 5-9. Specific points to be lubricated are:</p> <ol style="list-style-type: none"> <li>a. In recesses or grooves wherein the belt feed slide and the feed cam rides in the cover assembly.</li> <li>b. In breechblock camways and in receiver rail and cartridge rammer grooves of the barrel extension. On all rollers and roller riding surfaces.</li> <li>c. On the receiver rails and in the breech closing, hammer cocking, breech opening, and breechblock roller camming groove areas of the receiver.</li> </ol> <p>NOTE . LSA should be used sparingly. After lubricating, the components will be functioned to allow the oil to spread.</p>

Table 13-3. Specific Lubrication Instructions - Continued

STEP	PROCEDURE
<b>UNUSUAL CONDITIONS</b>	
1	<p>Reduce lubrication intervals to less than-90 days if inspection indicates rust or corrosion.</p> <p>NOTE Lubrication intervals may be shortened during inactive periods.</p>
2	<p>Changing grade of lubricants:</p> <p>a. Lubricants are prescribed in accordance with temperature ranges: above zero and below zero.</p> <p>b. When to change grade of lubricants is determined by maintaining a close check on the operation of the weapon during the approach to change over periods in accordance with weather forecast data.</p>
3	<p>Extreme cold weather lubrication is contained in TM 9-207.</p> <p>NOTE <u>Make certain all parts are dry and free from condensation, then lubricate.</u></p>
4	<p>Extreme hot weather or humid salt-air conditions require more frequent servicing since these conditions tend to dissipate the lubricants.</p>
5	<p>Lubricated surfaces are to be inspected and cleaned of fouled lubricants under sandy or dusty conditions.</p>
6	<p>After immersion, or as soon as tactical situation permits, accomplish steps 2 through 6, under usual conditions.</p>

Table 13-4. Cleaning and Inspection of 7.62MM Machine Gun M73E1

COMPONENTS	CLEANING AND INSPECTION
<p>Barrel Assembly Bore</p> <p>Chamber</p> <p>Back Plate Assembly with Solenoid Receiver Assembly</p>	<p style="text-align: center;"><b>CLEANING</b></p> <p>NOTE. General cleaning procedures, refer to TM 9-208-1, and TM 9-247.</p> <p>Remove foreign matter with CR, rifle bore cleaning compound, applied to cleaning patches and attached to small arms cleaning rod swab holder section 7266110 (3, fig. B-6). Use small arms cleaning bore brush 5564174 (8, fig. B-6) attached to small arms cleaning rod section 7266109 (2, fig. B-6) to clean any remaining foreign matter. Cleaning patches are used to wipe the bore clean.</p> <p>Insert small arms cleaning chamber brush 7790452 (7, fig. B-6) into the chamber and apply a counterclockwise motion to clean the barrel assembly chamber. CR, rifle bore cleaning compound, may be used, if necessary.</p> <p>Use only clean cloth to remove dirt.</p> <p>Clean the inside with small arms cleaning receiver brush 7790342 (5, fig. B-6) and CR, rifle bore cleaning compound. Wipe dry and apply a light coat of oil.</p>
<p>Jacket Assembly with Bearing Group</p> <p>Jacket Assembly with Bearing</p> <p>Barrel Assembly</p> <p>Cover Assembly</p> <p>Feed Tray Group</p>	<p style="text-align: center;"><b>INSPECTION</b></p> <p>Check mounting block for rough spots and cracks. Inspect all parts for rust, corrosion, and foreign matter. Inspect bearing lock for staking and bearing for damaged flash hider threads.</p> <p>Check for bulges, cracks, and rust.</p> <p>NOTE. A gap between the Stellite liner and the gun tube is allowed at manufacture to permit heat expansion. This ring approximately eight inches from rear end of barrel assembly does not reflect a ringed or bulged bore.</p> <p>Check feed cam for cracks and wear. Check spring action of depressor and stripper. Check feed slide assembly and feed slide track assembly for wear or damage. Assure that all pawls, under spring tension, function properly. Check cover and track assemblies for wear and damage.</p> <p>Make certain the cartridge stop assembly is secure to the feed tray assembly. Check tray for proper fit on receiver assembly.</p> <p>Guide Rod Assembly Check guide rod assemblies for straightness. Check compression and Compression helical spring for cracks and kinks.</p> <p>Helical Spring (Driving Spring)</p>

Table 13-4. Cleaning and Inspection of 7.62MM Machine Gun M73E1 - Continued

COMPONENTS	CLEANING AND INSPECTION
Back Plate Assembly with Solenoid Breechblock Assembly	Check spring action of solenoid trigger and sear of back plate assembly with solenoid. Check trigger safety for proper functioning. Check for freedom of movement of the roller. Check the spring action of the firing pin and make certain the firing pin will protrude from the breechblock.
Barrel Extension Assembly	Check rammer assembly. Make certain there is spring action in the cartridge extractor and firing pin extension. Make certain that hammer sear housing is tightly secured to the barrel extension. Check spring action of the hammer sear. Check lower assembly for freedom of action of rollers. Check action of hammer for proper functioning.
Charger Assembly	Check for loose parts. Pull on charger handle and check spring action.
Receiver Assembly	Check spring action of the right and left cover latch rod assemblies. Check the spring action of the buffer support lever assemblies by operating either lever. Examine camways of receiver body for cracks and wear. Make certain rate control slide retaining screws are tight and staked.

**Section 13-4. AMMUNITION****13-11. General**

Refer to SC 1305/30 IL for ammunition used

with 7.62MM machine gun M73 or M37E;

**Section 13-5. SHIPMENT AND LIMITED STOWAGE  
AND DEMOLITION TO PREVENT ENEMY USE****13-12. General (Refer to Chapter 6.)**

**APPENDIX I  
REFERENCES**

---

**A-1. PUBLICATION REFERENCES****OPERATOR/CREW**

AR 385-40 .....Safety: Accident Report and Records  
 AR 385-63 .....Safety: Regulations for Firing Ammunition for Training, Target Practice, and Combat  
 AR 700-1300-8 .....Logistics (General) Malfunctions Involving Ammunition and Explosives  
 DA Form 285 .....Accident Report  
 DA Form 348 .....Driver Qualification Record  
 DA Form 461-5 .....Limited Technical Inspection  
 DA Form 2028 .....Recommended Changes to DA Technical Publications  
 DA Form 2415 .....Ammunition Condition Report  
 SC 1305/30-IL .....Ammunition, through 30mm  
 SF Form 91 .....Operator's Report of Motor Vehicle Accident  
 TB 9-380-101 .....Security Classification of Missile and Large Rocket Systems and Components  
 TM 9-207 .....Operation and Maintenance of Ordnance Materiel in Extreme Cold Weather <sup>-0°</sup> to -65o  
 TM 9-208-1 .....Cleaning of Ordnance Materiel  
 TM 9-208-2 .....Cleaning, Drying, and Abrading Equipment for Cleaning Ordnance Materiel  
 TM 9-1300-206 .....Care, Handling, Preservation and Destruction of Ammunition  
 TM 9-2350-230-ESC .....Equipment Serviceability Criteria (ESC) for Armored Reconnaissance Airborne Assault Vehicle,  
 FT., 152MM Gun-Launcher, XM551  
 TM 11-5820-401-10 .....Radio Sets AN/VRC-12 and AN/VRC-43, -44, -45, -46, -47, -48, and -49  
 TM 11-5820-498-10 .....Operator's Manual: Radio Sets AN/VRC-53 and AN/GRC-125 and Amplifier-Power Supply Group  
 OA-3633/GRC  
 TM 21-301 .....Driver Selection, Training, and Supervision, Half-Track and Full Tracked Vehicles  
 TM 21-306 .....Manual for Full-Track Vehicle Driver  
 TM 38-750 .....The Army Equipment Record Procedures

## A-1. PUBLICATION REFERENCES - CONTNUED

## ORGANIZATIONAL MAINTENANCE

- DD Form 6 .....Report of Damaged or Improper Shipment
- DD Form 1397 .....Processing and Deprocessing Record for Shipment, Storage and Issue of Vehicles and Spare Engines
- FM 5-20B .....Camouflage Basic Principles
- TB 9-299/1 .....Processing of Unboxed Self-Propelled and Towed Class II Ordnance General Supplies and Related Materiel
- TB 9-1300-246/1 .....Identification of Ammunition Employing New Color Coding Standards
- TB 746-93-1 .....Color and Markings of Military Vehicles, Construction Equipment and Materials Handling Equipment
- TM 750-116 .....Organizational Maintenance Procedures for Purging and Charging of Fire Control Instruments.
- TB ORD 548 .....All Combat Vehicles: Failure of Azimuth Indicators, Sighting and Fire Control Instruments
- TB ORD 651 .....Use of Antifreeze Solution in Engine Cooling Systems
- TM 3-4240-236-20P .....Organizational Maintenance Repair Parts and Special Tool Lists: Filter Unit Gas Particulate, Tank, 12CFM, M8A3
- TM 9-213 .....Painting Instructions
- TM 9-1005-213-25 .....Organizational, DS, GS, and Depot Maintenance Manual Including Repair Parts and Special Tools Lists: Machine Gun, Caliber. 50; Browning M2, Heavy Barrel, Flexible.
- TM 9-1005-233-25 .....Organizational, DS, GS, and Depot Maintenance Manual Including Repair Parts and Special Tool Lists: Machine Gun, 7. 62MM, M73.
- TM 9-2350-230-25P/1 ...Organizational, Direct and General Support and Depot Maintenance Repair Parts and Special Tool List for Armored Reconnaissance Airborne Assault Vehicle: FT., 152MM Gun-Launcher, M551-Hull Suspension and Miscellaneous Components
- TM 9-2350-230-25P/2 ...Organizational, Direct and General Support and Depot Maintenance Repair Parts and Special Tool List for Armored Reconnaissance Airborne Assault Vehicle: FT., 152MM Gun-Launcher, M551-Turret Elevating and Traversing Systems, Cupola, Gun-Launcher, Small Arms and Fire Control
- TM 9-6140-200-15 .....Operation and Organizational, Field and Depot Maintenance, Storage Batteries, Lead-Acid Type
- TM 11-5820-401-20 .....Organizational Maintenance Manual: Radio Sets AN/VRC-12, -43, -44, -45, -46, -47, -48, and-49
- TM 11-5820-401-20P ....Organizational Maintenance Repair Parts and Special Tool Lists: Radio Sets AN/VRC-12, -43, -44, -45, -46, -47, -48 and -49
- TM 11-5820-498-20 .....Organizational Maintenance Manual: Radio Sets AN/VRC-53, AN/GRC-125 and Amplifier - Power Supply Group OA-3633/GRC



**APPENDIX II. BASIC ISSUE ITEMS LIST**  
**Section B-1. INTRODUCTION**

**B-1. Scope**

This appendix lists items which accompany the Armored Reconnaissance/Airborne Assault Vehicle (AR/AAV) M551 or are required for installation, operation, or operator's maintenance.

assemblies at DSU and GSU level. These assemblies will not be stocked above DS and GS level or returned to depot supply level.

**B-2. General**

This Basic Issue Items List is divided into the following sections: a. Basic Issue Items Section B-2. A list of items which accompany the AR/AAV M551 are required by the crew/operator for installation, operation, or maintenance.

M Repair parts which are not procured or stocked, but are to be manufactured indicated maintenance levels.

P Repair parts which are stocked in or supplied from the GSA/DSA or Army supply system, and authorized for use at indicated maintenance categories.

P2 Repair parts which are procured and stocked for insurance purposes because the combat or military essentially of the end item dictates that a minimum quantity be available in the supply system.

b. Maintenance a Operating Supplies Section B-3.. A listing of maintenance and operating supplies required for initial operation.

**B-3. Explanation of Columns**

The following provides an explanation of columns in the tabular list of Basic Issue Items, Section B-2.

X Parts and assemblies which are not procured or stocked and the mortality of which normally is below that of the applicable end item or component. The failure of such part or assembly should result in retirement of the end item from the supply system.

a. Source, Maintenance. and Recoverability Codes .(SMR)

X1 Repair parts which are not procured or stocked. The requirement for such items will be filled by use of the next higher assembly or component.

(1) Source code. Indicates the selection status or source for the listed item. Source codes are

Code	Explanation
A	Assemblies which are not procured or stocked as such, but are made up of two or more units. Such component units carry individual stock numbers and descriptions, are procured and stocked separately, and can be assembled to form the required assembly at indicated maintenance categories.
G	Major assemblies which are procured with PEMA funds for initial issue only as exchange

X2 Repair parts which are not stocked. The indicated maintenance category requiring such repair parts will attempt to obtain same through cannibalization. Where such repair parts are not obtainable through cannibalization, requirements will be requisitioned, with accompanying justification, through normal supply channels.

(2) Maintenance code, indicates the lowest category of maintenance authorized to install the listed item. The maintenance level code is:

Code	Explanation
C	Crew/operator
(3)	Recoverability code indicates whether unserviceable items should be returned for recovery or salvage. Items not coded are expendable. Recoverability codes are:

Code	Explanation
R	Applies to repair parts (assemblies and components) which are considered economically reparable at direct and general support maintenance levels. When the maintenance capability to repair these items does not exist, they are normally disposed of at the GS level. When supply considerations dictate, some of these repair parts may be listed by the pertinent NICP for automatic return to supply for depot level repair as set forth in AR 710-50. When so listed, they will be replaced by supply on an exchange basis.
S	Repair parts and assemblies which are economically reparable at DSU and GSU activities and are normally furnished by supply on an exchange basis. When determined to be uneconomically reparable by DSU and GSU activities, they will be returned to depot for evaluation and analysis prior to final disposition.
T	High dollar value recoverable repair parts which are subject to special handling and are issued on an exchange basis. Such repair parts are normally repaired or overhauled at depot maintenance activities.
U	Repair parts specifically selected for salvage by reclamation units because of precious metal content, critical materials, or high dollar value reusable casings or castings.
b.	Federal Stock Number, Column 2. This column indicates the Federal stock number assigned to the item and will be used for requisitioning purposes.
c.	Description, Column 3. This column indicates the Federal item name and any additional description of the item required. T abbreviation 'w/e', when used as a part

of the nomenclature, indicates the Federal stock J number includes all armament, equipment, accessories, and repair parts issued with the item. A part number or other reference number is followed by the applicable five-digit Federal supply code for manufacturers in parentheses.

d. Unit of Measure (U/M), Column 4. A 2 character alphabetic abbreviation indicating the amount or quantity of the item upon which the allowances are based, e.g., ft, ea, pr, etc.

e. Quantity Incorporated in Unit, Column 5. This column indicates the quantity of the item used in the functional group. A "V" appearing in this column in lieu of a quantity indicates that a definite quantity cannot be indicated (e.g., shims, spacers, etc.).

f. Quantity Furnished with Equipment, Column 6. This column indicates the quantity of an item furnished with the equipment.

g. Illustration, Column 7. This column is divided as follows:

- (1) Figure Number, Column 7a. Indicates the figure number of the illustration in which the item is shown.
- (2) Item Number, Column 7b. Indicates the callout number used to reference the item in the illustration.

#### **B-4. Explanation of Columns in the Tabular List of Maintenance and Operating Supplies Section B-3**

a. Component Application, Column 1. This column identifies the component application of each maintenance or operating supply item.

b. Federal Stock Number, Column 2. This column indicates the Federal stock number assigned to the item and will be used for requisitioning purposes.

c. Description, Column 3. This column indicates the item name and brief description.

d. Quantity Required for Initial Operation, Column 4. This column indicates the quantity of each maintenance or operating supply item required for initial operation of the equipment.

e. Quantity Required for 8 Hours Operation, Column 5. This column indicates the estimated quantities required for an average 8 hours of operation.

f. Notes, Column 6. This column indicates informative notes keyed to data appearing in a preceding column.

**B-5. Special Information**

a. Items listed below are components of the major combination.

Component	FSN
Machine Gun, Cal 50: M2, HB, flex	1005-726-5636
Machine Gun, 7.62-MM: M73 (coaxial)	1005-869-8816
or	
Machine Gun, 7.62-MM: M219 (M73E1)	1005-937-7327
Mount Assembly, Machine Gun: cal 50	1005-704-6650
Periscope, Tank: infrared M48 (driver's)	6650-762-9336
Consisting of:	
1-Body (in driver's compartment stowage box)	
1-Head (in driver's compartment stowage box)	
1-Headrest Assembly, Optical Instrument: (in periscope stowage box cover)	6650-907-9679
Periscope: M37 (loader's)	6650-856-9455
Periscope, Tank: M47	6650-788-5464
Quadrant, Fire Control, Gunner's: M1A1 w/case	1290-891-9999
Quadrant, Fire Control: elevation, M13A1C	1290-078-5568

Periscope, Tank: XM44 (early vehicle) 1240-788-5463

Periscope, Tank: XM44E1 (late vehicle) 1240-933-5630

Telescope, Articulated: M119 1240-762-9333

or  
Telescope, Articulated: XM127 1240-437-1254

Mount, Telescope: M149 1240-762-9334

or  
Mount, Telescope: M165 1240-178-8440

b. Identification of the usable on codes included in column 3 of this publication are:

Code	Used On
A	Caliber . 50 Machine Gun, M2
B	7, 62MM Machine Gun, M73
C	7. 62MM Machine Gun, M219 (M73E1)

**B-6. Abbreviations**

See MIL-STD-12.

**B-7. Federal Supply Code for Manufacturers**

Code	Manufacturer
10001	Naval Ordnance Systems Co.
19200	Frankford Arsenal
19204	Rock Island Arsenal
19205	Springfield Armory
19206	Watervliet Arsenal
19207	Army Tank-Automotive Command
80244	General Services Administration Federal Supply Service
81348	Federal Specifications
81349	Military Specifications
89372	North American Aviation Inc.
89875	Defense Supply Agency Directorate of Medical Materiel Defense Personnel Support Center
96906	Military Standard
99974	AC Electronics Div. of General Motors Corporation

## Section B-2. BASIC ISSUE ITEMS LIST

(1) SMR Code	(2) Federal Stock Number	(3) Description Ref no. & mfr Code Usable on code		(4) Unit of Meas	(5) Qty inc in Unit	(6) Qty furn with equip	(7) Illustration	
							(A) Fig no.	(B) Item No.
P C	6240-155-7836	GROUP 06 ELECTRICAL SYSTEM 0609 LIGHTS AND LAMPS LAMP, INCANDESCENT: 28v, .04 amp, no. 327 (In bulb box) (See tables 5-3 and 5-6) MS25237-327		ea	27	6		
P C	6240-019-3093	LAMP, INCANDESCENT: 28v, .37 amp, no. 623 (In bulb box) (See table 5-6) MS15570-623 (96906)		ea	3	3		
P C	6240-950-1727	LAMP: 28v, .08 amp, no. 757 (In bulb box) (S table 5-3)		ea	1	1		
P C	6240-019-0877	LAMP: 28v, .23 amp, no. 1251 (In bulb bx) (Stable 5-3) MS15570-1251 (96906)		ea	3	3		
P C	6240-044-6914	LAMP, INCANDESCENT: 28v, 1.02 amp, no. 1683 (In bulb bx) (See table 5-3) MS35478-1683		ea	1	1		
P C	6240-295-2668	LAMP, INCANDESCENT: 28v, .61 amp, no. 1691 (In bulb box) (See tables 5-3 and 5-6) MS35478-1691 (96906)		ea	3	3		
P C	6240-155-7967	LAMP: 14. 4v, . 10 amp, no. 1813 (In bulb bx) (See table 5-3) 8599150-004 (99974)		ea	1	1		
		GROUP 15 FRAME TOWING ATTACHMENTS AND DRAWBARS						
	2540-767-3149	1503 TOWING ATTACHMENTS CABLE ASSEMBLY: Steel, towing 3/4" x 10 ft (On hull exterior, rear) 10861718 (19207)		ea	1	1		
	2540-776-0103	PINTLE ASSEMBLY: (Turret, exterior left) MS51118-1 (96906)		ea	1	1		
		WASHER: Pintle mounting (Functional location) 10910174-14		ea	1	1		
		GROUP 18 BODY, CAB, HOOD AND HULL						
	2540-808-6858	1808 STOWAGE BOXES BOX ASSEMBLY: Spar lamp stowage (In oddment box) 11594202 (19207)		ea	1	1	B-1	1
		GROUP 22 BODY, CHASSIS OR HULL, AND ACCESSORY ITEMS						
	2540-670-2459	2201 CANVAS, RUBBER OR PLASTIC ITEMS BAG ASSEMBLY: Pamphlet (In driver's compartment) 7961712 (19207)		ea		1	B-1	2
	8465-705-2438	CASE: Ammunition (1-at loader's station, 1-n driver's compartment) MIL-C-43312 (81349)		ea		2	B-1	3
	2540-587-2532	TARPAULIN: Nylon 12 x 17 ft. (On turret exterior rack) 10936264 (19207)		ea		1		

(1) SMR Code	(2) Federal Stock Number	(3) Description  Usable on code	(4) Unit of Meas	(5) Qty inc in Unit	(6) Qty furn with equip	(7) Illustration	
						(A) Fig no.	(B) Item No.
		2202 ACCESSORY ITEMS					
	7240-242-6153	CAN, WATER: 5 gal. std. (On turret exterior) 64C 281 (80244)	ea		1		
	8345-178-8437	CASE: Flag CS-90 5-C-40 MIL-F-40045 (81349)	ea		1	B-1	4
	8345-227-1511	FLAG: MC-273 (Red) MIL-F-40045 (81349)	ea			B-1	5
	8345-227-1405	FLAG: MC-274 (Yellow) MIL-F-40045 (81349)	ea		1	B-1	6
	8345-227-1406	FLAG: MC-275 (Green) MIL-F-40045 (81349)	ea		1	B-1	7
	8345-242-3650	STAFF: Flag MIL-F-40045 (81349)	ea		3	B-1	8
	6230-264-8261	FLASHLIGHT: MX-991/U 6Z-4007-991 (1-n turret oddment box, 1-n driver's compartment) MIL-F-3747 (81349)	ea		2		
	6545-922-1200	KIT, FIRST AID: Motor vehicle, 12 unit size 1 (At turret commander's station) 9-221-220 (89875)	ea		1	B-1	11
	8415-266-8843	MITTENS, ASBESTOS: M1942 (At loader's station) MIL-M-11199 (81349)	pr		1		
	5340-912-4086	PADLOCK SET: 1-3/4" W/Clevis consisting of 1 lock, 2 keys (In tool bag) MS21313-160 (96906)	ea		1		
	8135-663-0196	TAPE, PRESSURE SENSITIVE ADHESIVE: waterproof (Roll) 3" ID core, 2" width, 60 yard roll PPP-T-60 (81348)	ea		1		
		GROUP 26 TOOLS AND TEST EQUIPMENT 2600 COMMON TOOLS					
	5140-473-6256	BAG, TOOL, (EMPTY) SACHEL: driver's compt. MIL-B-43533 (81349)	ea		1		
	5120-526-6044	Th following items are carried in tool bag BAR, Pinch, 9/16" x 11-7/8" Long 5266044 (19204)	ea		1		
	8020-297-6657	BRUSH, PAINT, Sash Oval (Parts Cleaning) 1-7/16" wide, 1-1/16" thick, 2-3/4" long. MS16866 (96906)	ea		2		
	5110-236-3272	CHISEL, Cold Hand, 3/4" x 6-1/2" long GGG-C-313 (81348)	ea		1		
	4930-288-1511	EXTENSION, Lube, Gun, Hyd, , 12" long MIL-L-4387 (81349)	ea		1		
	5120-240-8705	EXTENSION, Socket Wrench, 1/2" sq. dr. 20" long MS16243-11 (96906)	ea		1		

(1) SMR Code	(2) Federal Stock Number	(3) Description Ref no. & mfr Code	(4) Unit of Meas	(5) Qty inc in Unit	(6) Qty furn with equip	(7) Illustration	
						(A) Fig no.	(B) Item No.
		2600 COMMON TOOLS - Continued					
	4930-253-2478	GUN, Grease MIL-G-3859 (81349)	ea		1		
	5120-224-4047	HAMMER, Mach., Ball Peen, 2 lbs., Type II, Class 1, Style A GGG-H-86 (81348)	ea		1		
	5120-236-7590	HANDLE, Socket Wrench, Hinged, 1/2" sq. dr., 18" long MS16245-3 (96906)	ea		1		
	5120-230-6385	HANDLE, Socket Wrench, Ratchet, 1/2" sq. dr., 9-1/2" long MIL-W-15838 (81349)	ea		1		
	5120-198-5409	KEY, SOCKET HEAD SCREW: 5/16" Hex., 6-3/32" long (Nominal 6") GGG-K-275 (81348)	ea		1		
	5120-240-5292'	KEY, SOCKET HEAD SCREW: 1/8" Hex., 3-27/32" long (Nominal 3-3/4") GGG-K-275 (81348)	ea		1		
	5120-223-7397	PLIERS, Comb., Slip Joint, W/Cutter 8" long MS15382-1 (96906)	ea		1		
	5120-809-1570	SCREWDRIVER, Flat Tip, 18" Blade, 21-5/8" O/A MS15218-14 (96906)	ea		1		
	5120-198-5410	KEY, SOCKET HEAD SCREW: 3/16" Hex., 4-19/32" long, (Nominal 4-1/2" long) GGG-K-275 (81348)	ea		1		
	5120-260-4837	SCREWDRIVER, Flat Tip, 8" Blade 11-1/2" O/A MS15218-9 (96906)	ea		1		
	5120-224-7375	SCREWDRIVER, Cross Tip, Phillips, Tip Size No. 4, 6" Blade GGG-S-121 (81348)	ea		1		
	5130-714-0593	SOCKET, Socket Wrench, 1/2" sq. dr., 6 pt., 7/16" opening MS16581-11 (96906)	ea		1		
	5120-237-0984	SOCKET, Socket Wrench, 1/2" sq. dr., 12 pt., 1/2" opening M816254-22 (96906)	ea		1		
	5120-189-7932	SOCKET, Socket Wrench, 1/2" sq. dr., 12 pt., 9/16" opening MS16254-23 (96906)	ea		1		
	5120-189-7946	SOCKET, Socket Wrench, 1/2" sq. dr., 12 pt., 5/8" opening MS16254-25 (96906)	ea		1		
		5120-235-5870 SOCKET, Socket Wrench, 1/2" sq. dr., 12 pt., 11/16" opening MS16254-26 (96906)	ea		1		
	5120-189-7985	SQCKET. Socket Wrench, 1/2" sq. dr., 12pt., 3/4" openings M81624-27(96906)	ea		1		

(1) SMR Code	(2) Federal Stock Number	(3) Description Ref no. & mfr Code Usable on code	(4) Unit of Meas	(5) Qty inc in Unit	(6) Qty furn with equip	(7) Illustration	
						(A) Fig no.	(B) Item No.
		2600 COMMON TOOI00- Continued					
	5120-189-7933	SOCKET, Socket Wrench, 1/2" sq. dr., 12 pt., 13/16" opening MS16254-29 (96906)	ea		1		
	5120-189-7935	SOCKET, Socket Wrench 1/2" sq. dr., 12 pt., 15/16" opening MS16254-31 (96906)	ea		1		
	5120-189-7914	SOCKET, Socket Wrench, 1/2" sq. dr., 12 pt., 1-1/8" opening MS16254-34 (96906)	ea		1		
	5120-269-7971	UNIVERSAL JOINT, Socket Wrench, Hand, 1" sq. dr MS16257-3 (96906)	ea		1		
	5120-240-5328	WRENCH, Adj., Single End, 15/16" opening, 8" long MS15461-3 (96906)	ea		1		
	5120-224-3102	WRENCH, Open End, Fixed, Double Head Type, 5/8" and 3/4" openings MS16380-11 (96906)	ea		1		
	5120-187-7124	WRENCH, Open End, Fixed, Double Head Type, 1/2" and 9/16" openings MS16380-6 (96906)	ea		1		
	5120-187-7131	WRENCH, Open End, Fixed, Double Head Type, 7/8" and 15/16" openings MS16380-17 (96906)	ea		1		
	5120-187-7133	WRENCH, Open End, Fixed Double Head Type, 1" and 1-1/8" openings MS16380-20 (96906)	ea		1		
	5120-277-2342	WRENCH, Open End, Fixed, Double Head Type, 3/8" and 7/16" openings MS16380-4 (96906)	ea		1		
	5120-227-7387	WRENCH, Socket, Hand, Single Socket T-Type, 3/4" Hex, 6-1/2" O/A MS16260-5 (96906)	ea		1		
	5120-293-0139	WRENCH, Socket, Hand, Single Socket T-Type, 15/16" Hex, 7-3/4" O/A MS16260-8 (96906)	ea		1		
	5110-293-2336	2600 PIONEER TOOLS AX: Chopping, Single Bit, 4 lbs., hull exterior rear GGG-A-926 (81348)	ea		1	B-2	1
	5120-240-6040	CROWBAR: Pinch point, nor. dia. 1", 47" to 49" long, hull exterior rear GGG-B-101 (81348)	ea		1	B-2	2
	5120-243-2395	MATTOCK: Pick with Handle, 5 lbs. Hull exterior rear Consisting of: MATTOCK GGG-H-506 (81348)	ea		1	B-2	3
	5120-288-6574	HANDLE, MATTOCK-PICK NN-H-93 (81348)	ea		1		
	5120-293-3336 SH	HOVEL: General Purpose, D-Handle, Round Point, size 2 GGG-S-326 (81348)	ea		1	B-2	4

(1) SMR Code	(2) Federal Stock Number	(3) Description  Usable on code	(4) Unit of Meas	(5) Qty inc in Unit	(6) Qty furn with equip	(7) Illustration	
						(A) Fig no.	(B) Item No.
		2602 PUBLICATIONS					
	7510-889-3494	BINDER, EQUIPMENT LOG BOOK: (In pamphlet bag) MIL-B-43064 (81349)	ea		1		
		EQUIPMENT LOG BOOK: Order per TM 38-750 (In binder)	ea		1		
	L09-2350-230-12	LUBRICATION ORDER: (In pamphlet bag)	ea		1		
	TM9-2350-230-ESC	MANUAL, EQUIPMENT SERVICEABILITY CRITERIA: (In equipment log book binder)	ea		1		
	TM9-2350-230-12	MANUAL, OPERATOR'S AND ORGANIZATIONAL MAINTENANCE: (In pamphlet bag)	ea		1		
	FT-152-A-1 15 July 70	CANNON, 152MM GUN-LAUNCHER: M81EI and M81 on Armored Reconnaissance/Airborne Assault Vehicle: 152MM, M551, Firing Cartridge, 152MM: HEAT-MP-T, XM409E5; Cartridge, 152MM: TP-T, XM411E3; Cart- ridge, 152MM: HE-T, XM657E2; Cartridge, 152MM: 152MM: Cannister, XM625.					
		2604 SPECIAL TOOLS					
	5140-261-4994	CARRIER: Wire cutter (In tool bag) MIL-C-729 (81349)	ea		1	B-2	8
	5110-595-8229	CUTTER, WIRE: (In carrier in tool bag) MIL-C-386 (81349)	ea		1	B-2	7
	4910-906-1053	FIXTURE ASSEMBLY, TRACK: (Hull rear battery access ea door) 10955739 (19207)	1			5-5	
	5120-449-7042	HANDLE: Steel tubular, 24" long, 7/8" ID. (Hull rear battery access door, strapped w/track fixture) GGG-W-636, Type 19, Class 1 (81348)	ea		1	B-2	6
	5120-678-2795	PUNCH ASSEMBLY: Drift pin (In tool bag) 11861180 (19207)	ea		1	5-5	
	5120-288-9681	WRENCH: Box Socket, Stub End 1-1/8" opening (In tool bag) GGG-W-636, Type 18, Class 1, (81348)	ea		1	B-2	5
		<b>B-8</b>					



(1) SMR Code	(2) Federal Stock Number	(3) Description Ref no. & mfr Code Usable on code		(4) Unit of Meas	(5) Qty inc in Unit	(6) Qty furn with equip	(7) Illustration	
							(A) Fig no.	(B) Item No.
		GROUP 34 - ARMAMENT AND FIRE CONTROL						
		3401 PRIMARY ARMAMENT: TOOLS AND EQUIPMENT FOR 152MM GUN/LAUNCHER M81, M81 MOD, AND M81E1						
P C	4933-435-7736	NOTE. M81 Mod is modified for CBSS. ACTUATOR, ELECTRO-MECHANICAL LINEAR: Firing pulse 11643755 (19207)		ea		1	4-4	
P C R	1025-918-5476	BRUSH,BORE ASSEMBLY: Bore and groove (In cover on hull battery access door) (M81 and M81 Mod. ) 8769852 (19206)		ea		1	B-3	1
P C	1025-112-8552	BRUSH, BORE ASSEMBLY: (M81E1 Gun-Launcher only) 11578061 (19206)		ea			B-3	1
P C	2540-134-4754	COVER ASSEMBLY: Ammo protective (In hull ammo rack) 11652963 (19206)		ea		34	3-3	
P C	1025-918-5474	COVER, ASSEMBLY: Bore brush for M81andM81Mod gun-launcher (On hull battery access door) 8769816 (192065)		ea		1	B-3	2
P C	4933-852-6310	BORESIGHT ASSEMBLY: 11577285 (19206)		ea		1	B-3	3,4
<b>(B-8.2 Blank) B-8.1</b>								

(1) SMR Code	(2) Federal Stock Number	(3) Description Ref no. & mfr. Code Usable on code	(4) Unit of Meas	(5) Qty inc in Unit	(6) Qty furn with equip	(7) Illustration	
						(A) Fig no.	(B) Item No.
P C	1025-435-7733	3401 PRIMARY ARMAMENT: TOOLS AND EQUIPMENT FOR 152MM GUN/LAUNCHER M81, M81 MOD., AND M81E1 - Continued COVER ASSEMBLY: Bore brush for M81E1 gun-launcher (On hull battery access door) 11578227 (19206)	ea		1	B-3	2
P C	5120-287-2130 -	SCREWDRIVER: Offset, 4-1/2"lg. 5/16" wide ,hexagonal (In tool bag)	ea		1	5-10.1	
P C	1025-918-8129	PLUG, MUZZLE: (On gun/launcher) 8769799 (19206)	ea		1	B-3	7
P C	1025-918-8130	RAMMER, ARTILLERY: (On hull battery access door) 8769846 (19206)	ea		1	B-3	8
P C	1090-563-7232	STAFF, SECTION, CLEANING ARTILLERY: M15 (On hull rear exterior) 7309228 (19206)	ea		3	B-3	9
P C	5350-242-4404	STEEL WOOL: (To clean firing probe) (In tool bag) 11577277 (19206)	lb		1		
P C	9525-063-1444	WIRE, STEEL, CORROSION RESISTING: (In tool bag) MS9226-05 (96906)	ft		1		
		3402 SECONDARY ARMAMENT					
P C	5306-051-4078	BOLT: Machine (To attach spent brass ejection chute) (Functional location) MS90727-36 (96906)	ea	2	2	3-14	
P C	1025-844-3560	CLAMP: Spent brass ejection chute (Functional location) 11593536 (19207)	ea	1	1	3-14	
P C	1025-844-3488	CHUTE: Spent brass ejection (Functional location) 11593535 (19207)	ea	1	1	3-14	
P C	5310-194-0636	WASHER: Flat (to attach chute) (Functional location) MS9320-11 (96906)	ea	2	2	3-14	
		REPAIR PARTS FOR CAL 50 MACHINE GUN					
P C	1005-726-6131	BARREL: Spare, Cal 50 M2 HB (On turret exterior A rack) 7266131 (19205)	ea	1	1	B-7	
P C	1005-614-7463	BOLT ASSEMBLY: Alternate feed (In spare parts box) A 6147463 (19204)	ea	1	1	B-4	12
P C	1005-600-8976	EXTENSION ASSEMBLY: Firing pin (On alt. feed bolt) A 6008976 (19204)	ea	1	1	B-4	10
P C	1005-600-8959	EXTRACTOR: Small arms cartridge (On alt. Feed A bolt) 6008959 (19204)	ea	1	1	B-4	1

(1) SMR Code	(2) Federal Stock Number	(3) Description  Usable on code	(4) Unit of Meas	(5) Qty inc in Unit	(6) Qty furn with equip	(7) Illustration	
						(A) Fig no.	(B) Item No.
P C	1005-600-9718	REPAIR PARTS FOR CAL 50 MACHINE GUN-Continued LEVER, COCKING: (On alt. feed bolt)A 6009718 (19204)	ea	1	1	B-4	4
P C	1005-716-1300	LOCK, ACCELERATOR STOP: (On alt. feed bolt)A 7161300 (19205)	ea	1	1	B-4	5
P C	1005-731-2078	PIN, COCKING LEVER: (On alt. feed bolt) A 7312078 (19205)	ea	1	1	B-4	3
P C	1005-731-0080	PIN, FIRING: (On alt. feed bolt)A 7310080 (19204)	ea	1	1	B-4	11
P C	1005-550-4067	SEAR: (On alt. feed bolt)A 5504067 (19204)	ea	1	1	B-4	8
P C	1005-535-1220	SLIDE, SEAR: (On alt. feed bolt) A 5351220 (19204)	ea	1	1	B-4	7
P C	1005-209-8720	SPRING, SEAR: Helical compression (On alt. Feed A bolt) 5009524(19204)	ea	1	1	B-4	9
P C	1005-716-1301	STOP, ACCELERATOR: (On alt. feed bolt) A 7161301 (19205)	ea	1	1	B-4	6
P C	1005-550-4062	SWITCH, BOLT: Alternate feed (On alt. Feed A bolt) 5504062 (19204)	ea	1	1	B-4	2
		TOOLS AND EQUIPMENT FOR CAL 50 MACHINE GUN					
	1005-714-8550	BOX, SPARE PARTS: (Empty) (In turret oddment A box) 7148550 (19204)	ea		1	B-5	1
	1025-844-2716	BRACKET ASSY: Mounting, Weapon Sight (On A cal 50 machine gun or stowage bracket) 11619652 (19207)	ea		1	2-29	
	1005-508-2589	BRUSH, CLEANING, SMALL ARMS: Chamber (In case A 8407954 (19204)	ea		1	B-5	11
	1005-550-4037	BRUSH, CLEANING, SMALL ARMS: M4,Bore (In A case) 5504037 (19204)	ea		4	B-5	8
	1005-716-2702	BRUSH, CLEANING, SMALL ARMS: Firing Pin A Hole (n case) 7162702 (19205)	ea		1	B-5	5
	8105-921-5821	CASE, SMALL ARMS, ACCESSORIES: (In A turret oddment box) 11686430 (19204)	ea		1	B-5	2
	1005-714-6365	COUPLER DISCONNECTOR: Cal 50 M20 A 7146365 (19204)	ea		1		

B-10

(1) SMR Code	(2) Federal Stock Number	(3) Description Ref no. & mfr Code Usable on code		(4) Unit of Meas	(5) Qty inc in Unit	(6) Qty furn with equip	(7) Illustration	
							(A) Fig no.	(B) Item No.
		TOOLS AND EQUIPMENT FOR CAL 50 MACHINE GUN - Continued						
	1005-735-7116	COVER, MACHINE GUN: (On cal.-.50 machine gun) 7357116 (19207)	A	ea		1		
	1005-796-4436	COVER, SPARE BARREL: (On spare barrel) 7964436 (19207)	A	ea		1	B-5	7
	4933-716-0041	EXTRACTOR, RUPTURED CARTRIDGE CASE: (In case) 7160041 (19204)	A	ea		1	B-5	10
	4933-535-1217	GAGE, HEADSPACE AND TIMING: (In case) 53511217 (19207)	A	ea		1	B-5	9
	1005-716-2072	FLASH, HIDER: (On cal 50 machine gun) 7162072 (19204)	A	ea		1	3-13	
	1005-556-4102	ROD, CLEANING, SMALL ARMS: M4 (In case) 5564102 (19204)	A	ea		1	B-5	4
	1005-653-5441	ROD, CLEANING, SMALL ARMS: M7 jointed (In case) 6535441 (19204)	A	ea		1	B-5	3
	1005-716-2704	SWAB, HOLDER SECTION: Small arms cleaning rod (In case) 7162704 (19205)	A	ea		1	B-5	6
		7. 62MM MACHINE GUN						
P C	1025-134-3051	EXTENSION ASSEMBLY, SPENT BRASS EJECTION CHUTE: (Functional location 11643756 (19207)	BC	ea	1	1	3-7	
P C	5305-983-6651	SCREW: (To attach extension) (Functional location) MS16998-27 (96906)	BC	ea	2	2	3-7	
		REPAIR PARTS FOR 7. 62MM MACHINE GUN						
P C	1005-972-0196	BARREL ASSY: (Hull right sponson) 7792874 (19204)	BC	ea	1	1	5-11,12 13-1	4
P C R	1005-921-6317	BREECHBLOCK ASSEMBLY: (In spare parts box) 11013422 (19205)	BC	ea	1	1	5-11,12 13-1	12
P C R	1005-937-8256	EXTENSION ASSEMBLY, BARREL: (Used w/M73 only) (In spare parts box) 11013360 (19204)	B	ea	1	1	5-11,12	
P C R	1005-832-9612	EXTENSION ASSEMBLY, BARREL (Used on M73E1 only) (In spare parts box) 11013432 (19204)	C	ea	1	1	13-1	13

(1) SMR Code	(2) Federal Stock Number	(3) Description Ref no. & mfr Code Usable on code	(4) Unit of Meas	(5) Qty inc in Unit	(6) Qty furn with equip	(7) Illustration		
						(A) Fig no.	(B) Item No.	
P C	5340-209-6975	REPAIR PARTS FOR 7. 62MM MACHINE GUN - Cont'd. RING, RETAINING: Ext., S, Phos - Ctd., 0. 302 ID, 3/8 shaft dia. (In spare parts box) MS16333-3037 (96906)	B	ea	3	3	5-11,12	
P C	5340-209-6975	RING, RETAINING: Ext., S, Phos - Ctd., 0. 302 ID, 3/8 Shaft Dia (In spare parts box) MS16333-3037 (96906)	C	ea	2	2	13-1	15
P C	1005-856-7995	SPRING, HELICAL COMPRESSION: 9. 100 Free Lg. , Driving (In spare parts box) 7792838 (19207)	BC	ea	2	2	5-11,12 13-1	9
P C	1005-832-9613	STUD, MOUNTING, CHARGER: (In spare parts box) (Used w/M73E1 only) 11013434 (19204)	C	ea	1	1	13-1	17
		TOOLS AND EQUIPMENT FOR 7. 62MM MACHINE GUN						
	1005-714-5250	BOX, SPARE PARTS: (Empty) (In driver's compartment) 7790683 (19205)	BC	ea		1	B-6	6
	1005-556-4174	BRUSH, CLEANING, SMALL ARMS: Bore (in case) 5564174 (19204)	BC	ea		4	B-6	8
	1005-650-4508	BRUSH, CLEANING, SMALL ARMS: Receiver (In case) 7790342 (19205)	BC	ea		1	B-6	5
	1005-690-3115	BRUSH, CLEANING, SMALL ARMS: Chamber (In case) 7790452 (19205)	BC	ea		1	B-6	7
	1005-694-1662	BUFFER, CLEANING ROD: (In case) 7268275 (19205)	BC	ea		1	B-6	11
	1005-550-6573	CASE, SMALL ARMS CLEANING ROD: (Turret oddment box) 5506573 (19204)	BC	ea		1	B-6	1
	14933-733-4759	COMBINATION TOOL: (In spare parts box) '7791083 (19205)	BC	ea		1	B-8	4
	4933-652-9950	EXTRACTOR, RUPTURED CARTRIDGE CASE: (In spare parts box) 7790352 (19205)	BC	ea		1	B-6	12
	1005-922-9777	FLASH HIDER:(On machine gunr 11013420 (19204)	BC	ea		1	B-6	13
	1005-793-6761	HANDLE ASSY., CLEANING ROD: (In case) 7266115 (19204)	BC	ea		1	B-6	10
	9150-889-3522	LUBRICATING OIL, SEMIFLUID: (LSA) 4 oz bottle (In spare parts box) MIL-L-46000 (81349)	BC	ea		1	B-6	9
	5120-242-5966	PUNCH, DRIVE PIN: Straight, 3/4" lg, 1/8" dia. pt. GG-P-00831 (81348)	BC	ea		1	5-13	

(1) SMR Code	(2) Federal Stock Number	(3) Description  Ref no. & mfr Code Usable on code		(4) Unit of Meas	(5) Qty inc in Unit	(6) Qty furn with equip	(7) Illustration	
							(A) Fig no.	(B) Item No.
P C	1005-726-6109	TOOLS AND EQUIPMENT FOR 7. 62MM MACHINE GUN- Continued ROD SECTION, CLEANING, SMALL ARM; (In case) 7266109 (19205)	BC	ea		5	B-6	2
P C	1005-726-6110	SWAB HOLDER SECTION, SMALL ARMS CLEANING ROD: (In case) 7266110 (19204)	BC	ea		1	B-6	3
P C	5120-264-3793	WRENCH: Auto adj., 15" lg O/A, 0 to 3-5/8 min. jaw opening cap (In spare parts box) GGG-W-631 Type E2 (81348)	BC	ea		1	5-13	
3403 SIGHTING AND FIRE CONTROL EQUIPMENT								
P C	1220-624-3415	PLATE, INSTRUCTION: (Range card) (In pamphlet bag) 8724207 (19207)		ea		1	B-3	5
P C	1240-950-1605	BORESIGHT AID ASSEMBLY: u/o XM44 Periscope (In pamphlet bag) 10516830 (19200)		ea		1	B-3	6
P C	5340-792-9974	PLUG, PROTECTIVE, DUST AND MOISTURE SEAL: cover, telescope (Functional location) 11636162 (19207)		ea		1	10-49.1	
P C	1240-238-5778	COVER, PERISCOPE: plastic (for XM44E series to cover cavities when head and body are separated) 11732210 (19200)		ea		2		
3404 PARTS, SIGHTING AND FIRE CONTROL								
P C	6135-120-1010	BATTERY, DRY, 1. 5v "C" size Type BA 42 MIL-B-18 (81349)		ea		2		
P C	6240-155-7836	LAMP, INCANDESCENT: 28v .04 amp., no. 327 (In bulb box) (See table 5-6) MS25237-327 (96906)		ea	3	3		
P C	6240-817-9803	LAMP, INCANDESCENT: 6v, .70 amp, no. 316 (In bulb box) (See table 5-6) MS25231-316 (96906)		ea	3	3		
P C	6240-921-4493	LAMP, INCANDESCENT (In bulb box) (See table 5-6) 8624583 (19200)		ea	3	3		

(1) SMR Code	(2) Federal Stock Number	(3) Description  Usable on code		(4) Unit of Meas	(5) Qty inc in Unit	(6) Qty furn with equip	(7) Illustration	
							(A) Fig no.	(B) Item No.
		GROUP 48 - FOOD PREPARATION EQUIPMENT RANGE 4815 RANGE						
P C	7310-285-6155	STOVE, COOKING: Gasoline, M1950 w/case (In driver's compartment) MIL-S-10736 (81349)		ea		1		
P C	7310-281-2215	Consisting of: STOVE: M1950 MIL-S-10736 (81349)		ea		1	B-1	9
P C	7310-379-2418	CASE: M1950 Stove 264985PC 25 (10001)		ea		1	B-1	10
		GROUP 76 - FIRE FIGHTING EQUIPMENT COMPONENTS						
P C	4210-555-8837	7603 FIRE EXTINGUISHERS EXTINGUISHER: Fire Portable 2-3/4 lbs. monobromotri- flourmethane (CF3BR), w/bracket (At turret commander's station) MIL-E-52031 (81349)		ea		1	2-18	
		<b>B-14</b>						

## Section B-3. MAINTENANCE AND OPERATING SUPPLIES

(1) COMPONENT APPLICATION	(2) FEDERAL STOCK NUMBER	(3) DESCRIPTION	(4) QTY REQ'D. FOR INITIAL OPERATION	(5) QTY REQ'D. FOR 8 HOURS OPERATION	(6) NOTES
Air pressure gage	8030-134-3692	The following items are listed for informational purposes only.			
All armament	8030-134-3692	SELANT LIT: 5702948 (19207)			Usage restricted to organizational maintenance
All armament	6850-965-2332	CARBON REMOVING COMPUND: P-C-111 (81348)  5 gal pail			
All armament	6850-224-6565	CLEANING COMPUND, RIFLE BORE: solution type MIL-C-372 (81349)  2 oz plastic bottle			
	6850-224-6657	6 oz can			
	6850-224-6663	1 gal can			
Ammunition detent CBSS check valve	9150-949-0323	LUBRICATING OIL, SEMIFLUID: MIL-L-46150 (81349)  8 oz plastic tube			
Compressor	9150-753-4667	LUBRICATING OIL, AIR COMPRESSOR: BMS3-7A (82918)  1 qt			
Driver's rotatable hatch Driver's escape hatch cover Headlight assembly	8040-664-4318	ADHESIVE: syn-rbr base, type II MIL-A-5092 (81349)  1 pt can			
Engine	6850-243-1992	ANTIFREEZE: 0-A-548m, Type 1 (81348)  1 gal can			
	6850-224-8730	5 gal pail			
	6850-174-1806	ANTIFREEZE: arctic type MIL-C-11755 (81349)  55 gal drum			



## Section B-3. MAINTENANCE AND OPERATING SUPPLIES

(1) COMPONENT APPLICATION	(2) FEDERAL STOCK NUMBER	(3) DESCRIPTION	(4) QTY REQ'D. FOR INITIAL OPERATION	(5) QTY REQ'D. FOR 8 HOURS OPERATION	(6) NOTES
Engine, transmission	9150-265-9425 9150-265-9428 9150-265-9433 9150-265-9435  9150-242-7602 9150-242-7603 9150-242-7604	LUBRICATING OIL, ENGINE: heavy duty MIL-L-2104 (81349) OE-10 1 qt can 5 gal can OE-30 1 qt can 5 gal can  OES LUBRICATING OIL, ENGINE: sub-zero MIL-L-10295 (81349) 1 qt can 5 gal pail 55 gal drum			
Fire Control	9150-664-6518 9150-223-4129	LUBRICATING OIL, INSTRUMENT: MIL-L-6085 (81349) 1-1/2 oz bottle 1 qt can			
Fire Control equip-	9150-273-8633 9150-269-8255	GPS GREASE, AIRCRAFT 8 oz tube 1 lb can			
Grease Gun 4930-253-2478	9150-935-1017	GREASE, AUTOMOTIVE AND ARTILLERY: MIL-G-10924 (81349) 14 oz cartridge			
Gun-launcher Headlight assy	6850-880-7616	SILICONE COMPOUND: MIL-S-8660 (81349) 8 oz tube			
Headlight assembly	8030-965-2438	SEALING COMPUND: tape, type III MIL-S-11030 (81349) 60 ft roll			
Lens (Missile Subsystem)	6810-242-3645	ETHYL ALCOHOL, ABSOLUTE, ACS: O-C-265 (81348) 1 gal can			

(1) COMPONENT APPLICATION	(2) FEDERAL STOCK NUMBER	(3) DESCRIPTION	(4) QTY REQ'D. FOR INITIAL OPERATION	(5) QTY REQ'D. FOR 8 HOURS OPERATION	(6) NOTES
Optical, Fire Control Instruments (1) (2) (3) (4) Reservoir, Periscope Washer & Pump Assy  Periscope M47/ M48 (4) Periscope XM44/	6850-227-1887	CLEANING COMPUND, LENS: Liquid (1 qt container)	1 qt		1. Clean exterior optical surfaces, eye-lens, objective lens, windows, etc.
	6850-558-1248	ANTI-ICING AND DEICING DEFROSTING FLUID: (1 gal container) MIL-A-8243 (81349)	1 gal		2. CAUTION: <u>Do not touch optics will bare fingers. Oil and acid from fingers will etch optics if not removed.</u>
Telescopes Periscopes	8020-224-8024	BRUSH ARTIST: mtl ferrule, round taper point, style 9, Camel hair, 1-1/16 lg, 1/4 in. dia at ferrule	1		3. CAUTION: <u>In cold weather, avoid blowing breath on optical surfaces to prevent deposits of condensation which may freeze.</u>
Periscope XM44 series emergency battery Telescopes Perscopes	6810-543-4041	POTASSSIUM HYDROXIDE: electrolyte			4. To prevent marring optical windows, always pump defrosting fluid or water on dry or dusty head windows before operation of wipers.
Radio equipment	6640-285-4694	PAPER, LENS: 100 sheets (7 x 11) in envelope NNN-P-40, Type 4 (81348)			
Recoil mechanism	6850-597-9765	CLEANING COMPOUND, SOLVENT: MIL-C-18718 (81349) 1 gal can GMD GREASE, MOLYBDENUM DISULFIDE: liquid, gelling agent MIL-G-21164 (81349)			
Small Arms	9150-223-4001 9150-223-4004 9150-965-2003	1 lb can 5 lb can 35 lb pail OHT HYDRAULIC FLUID, PETROLEUM BASE: MIL-H-6083 (81349)			
	9150-935-9807 9150-935-9808 8020-244-0153	1 qt can 1 gal can BRUSH ARTISTS: metal ferrule, flat chisel edges, 7/16w, 1-1/8 lg, exposed bristle H-B-241, Style 5 (81348)			

(1) COMPONENT APPLICATION	(2) FEDERAL STOCK NUMBER	(3) DESCRIPTION	(4) QTY REQ'D. FOR INITIAL OPERATION	(5) QTY REQ'D. FOR 8 HOURS OPERATION	(6) NOTES
Small Arms	7920-205-2401	BRUSH, CLEANING, TOOL AND PARTS: rd, 100 percent tampico fiber, 1-1/16 brush dia (at ferrule), 2-7/8 brush lg (clear of block)			
Small Arms	9150-273-2389	PL-special LUBRICATING OIL, GENERAL PURPOSE: VV-L-800 (81348)			
Small Arms	9150-231-6689	4 oz can			
Small Arms	9150-889-3522	LSA LUBRICATING OIL, SEMIFLUID: AUTOMATIC WEAPONS			For 7, 62MM machine gun only
Small Arms	9150-687-4241	MIL-L-46000 (81349)			
Small Arms	9150-753-4686	4 oz tube			
Small Arms	9150-664-0038	1 qt can			
Small Arms	9150-292-9689	LAW LUBRICATING OIL, WEAPONS: LOW TEMP, CORROSION AND OXIDATION RESISTANT			
Small Arms	9150-292-9687	MIL-L-14107 (81349)			
Small Arms	7920-205-1711	4 oz can			
Small Arms	7920-234-8467	1 qt can			
Small Arms	1005-288-3565	5 gal pail			
Small Arms	7920-205-1711	RAG WIPING: cotton white, bleached			
Small Arms	7920-234-8467	50 lb bale			
Small Arms	1005-288-3565	100 lb bale			
Small Arms	9150-288-3565	SWAB, SMALL ARMS CLEANING: cotton, 2-1/2 sq, 1000 in pkg			
Small Arms	5019316 (19205)	5019316 (19205)			
Small Arms	9150-190-0904	GAA GREASE, AUTOMOTIVE AND ARTILLERY:			
Small Arms	9150-190-0905	MIL-G-10924 (81349)			
Small Arms	9150-190-0904	1 lb can			
Small Arms	9150-190-0905	5 lb can			
Small Arms	9150-257-5370	GG-1 GREASE, GRAPHITE: soft VV-G-671, Grade 1 (81348)			
Small Arms	9150-257-5370	1 lb can			

(1) COMPONENT APPLICATION	(2) FEDERAL STOCK NUMBER	(3) DESCRIPTION	(4) QTY REQ'D. FOR INITIAL OPERATION	(5) QTY REQ'D. FOR 8 HOURS OPERATION	(6) NOTES
Turret electrical system, XM44 Series periscope  Turret traverse mech gear box, fire control equipment	8040-867-4358	ADHESIVE: MIL-A-46106 (81349)  5 oz tube			
		GIA GREASE, AIRCRAFT AND INSTRUMENT MIL-G-23827 (81349)			
	9150-985-7244	4 oz tube			
	9150-985-7246	1 lb can			
	9150-985-7247	5 lb can			
		ADHESIVE: reclaimed-ru, liquid, general purpose MIL-A-5092, Type 1 (81349)			
	8040-262-9025	4 oz tube			
	8040-262-9028	1 pt can			
	8040-262-9031	1 qt can			
	8020-242-7266	BRUSH, PAINT: flat, mtl bound, med grade 3 w H-B-420 (81348)			
		CLOTH, ABRASIVE: aloxide, jean cloth back, closed coat, 9 w, 11 lg P-C-451, Type 1, Class 1 (81348)			
	5350-192-5047	grit no. 80 50 sheet sleeve			
	5350-192-5049	grit no. 120 50 sheet sleeve			
	5350-192-5051	grit no. 180 50 sheet sleeve CA - CLOTH, ABRASIVE: crocus, ferric oxide and quartz, jean-cloth-back, closed coat, 9 w, 11 lg P-C-458 (81348)			
	5350-221-0872	50 sheet sleeve COMPOUND, non-slip, o. d., color no. X24087			
	5610-782-5555	1 qt can			
	5610-782-5556	1 gal can SD - DRY CLEANING SOLVENT: P-D-680, Type 1 (81348)			
6850-664-5685	1 qt can				
6850-281-1985	1 gal can				

(1) COMPONENT APPLICATION	(2) FEDERAL STOCK NUMBER	(3) DESCRIPTION	(4) QTY REQ'D. FOR INITIAL OPERATION	(5) QTY REQ'D. FOR 8 HOURS OPERATION	(6) NOTES
	8010-297-2105 8010-577-4381	ENAMEL: semi-gloss, rust inhibiting, od no. X24087 TT-E-485, Type IV (81348) 1 gal can 5 gal pail			Pressurized
	8010-598-5936 8010-297-2109	ENAMEL: semi-gloss, rust inhibiting, od no. X24087 TT-E-485, Type II (81348) 12 oz can 1 pt can			
	8010-297-0560 8010-297-0561	ENAMEL: alkyd, lusterless, od no. X34087 TT-E-527 (81348) 1 gal can 5 gal pail			
	9150-905-9100 9150-577-5840	GO LUBRICATING OIL, GEAR: UNIVERSAL TYPE MIL-L-2185, GRADE 80 (81349) 1 gal can 5 gal pail			Not for small arms.
	9150-261-7904 9150-257-5440	GOS LUBRICATING OIL, GEAR: UNIVERSAL TYPE, SUB-ZERO MIL-L-10324 (81349) 1 qt can 5 gal pail			
	9150-231-2360 9150-231-2361 9150-231-2356	PL - medium LUBRICATING OIL, GENERAL PURPOSE: MIL-L-3150 (81349) 2 oz can 1 qt can 5 gal pail			
	8135-551-1245	TAPE, ADHESIVE: pressure sensitive, water resistant, od 7, 4 in. x 60 yd roll JAN-P-127, Type 1 Grade B			
	8010-242-2089 8010-558-7026	TPM - THINNER, PAINT, MINERAL SPIRITS: TT-T-291, Grade 1 (81348) 1 gal can 5 gal pail			

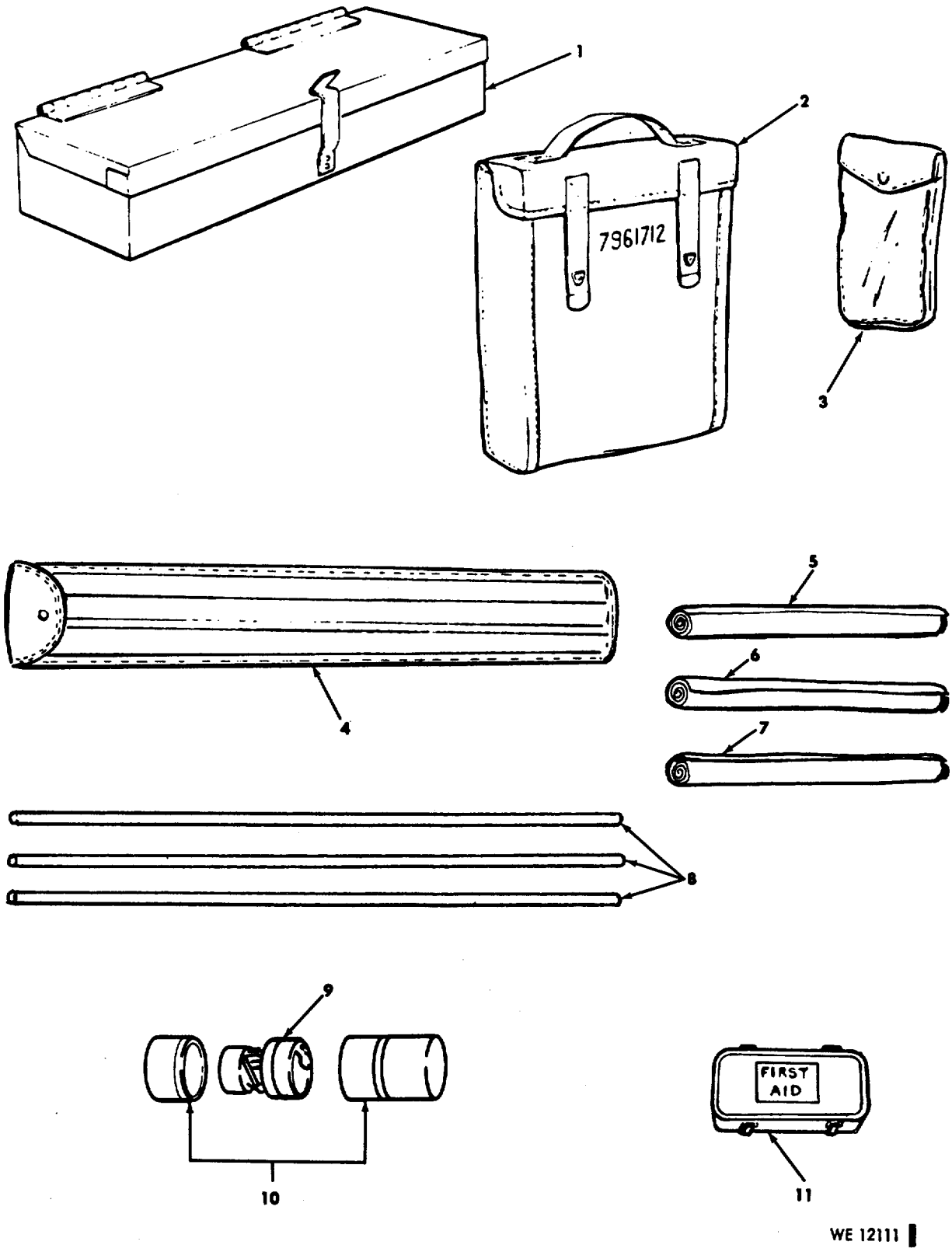
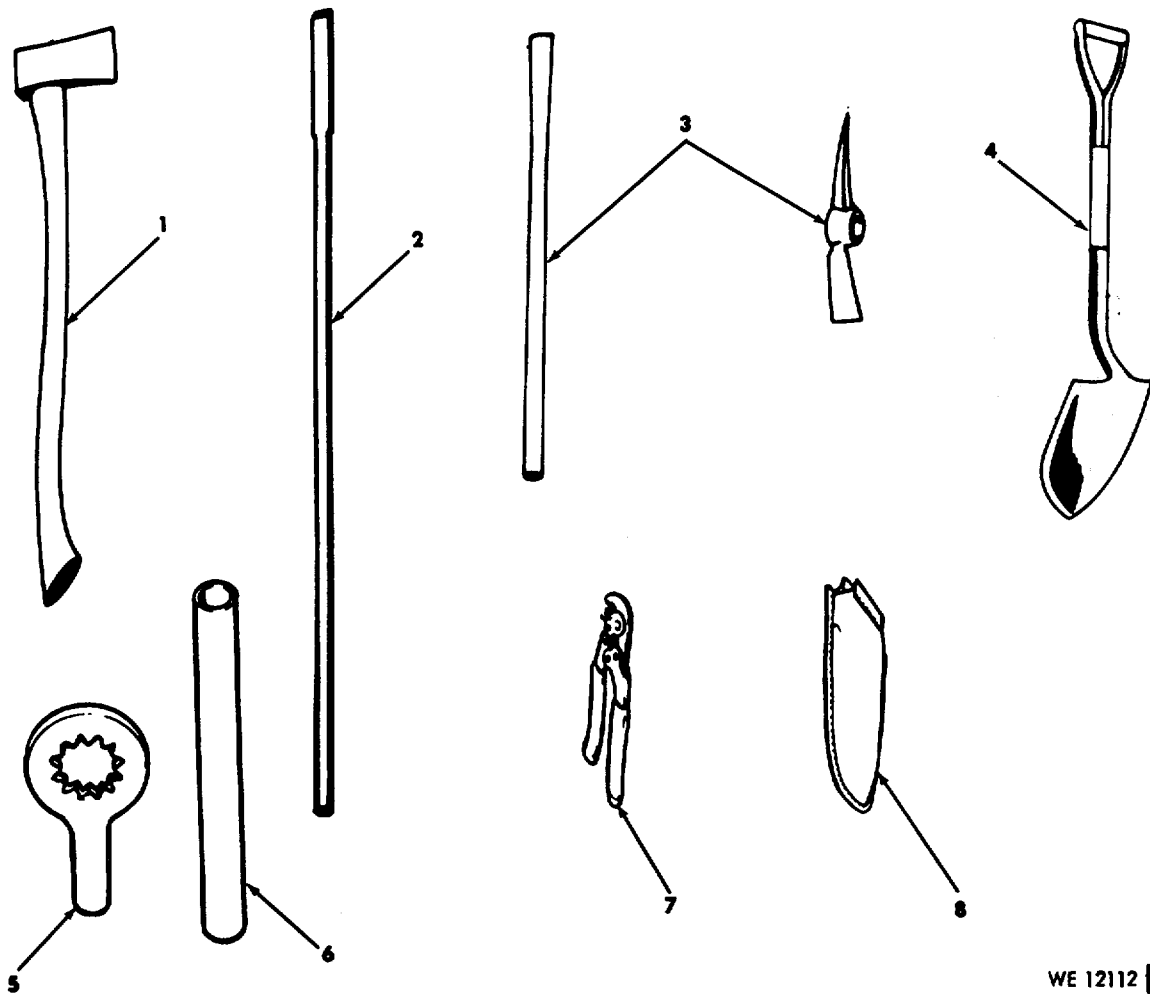
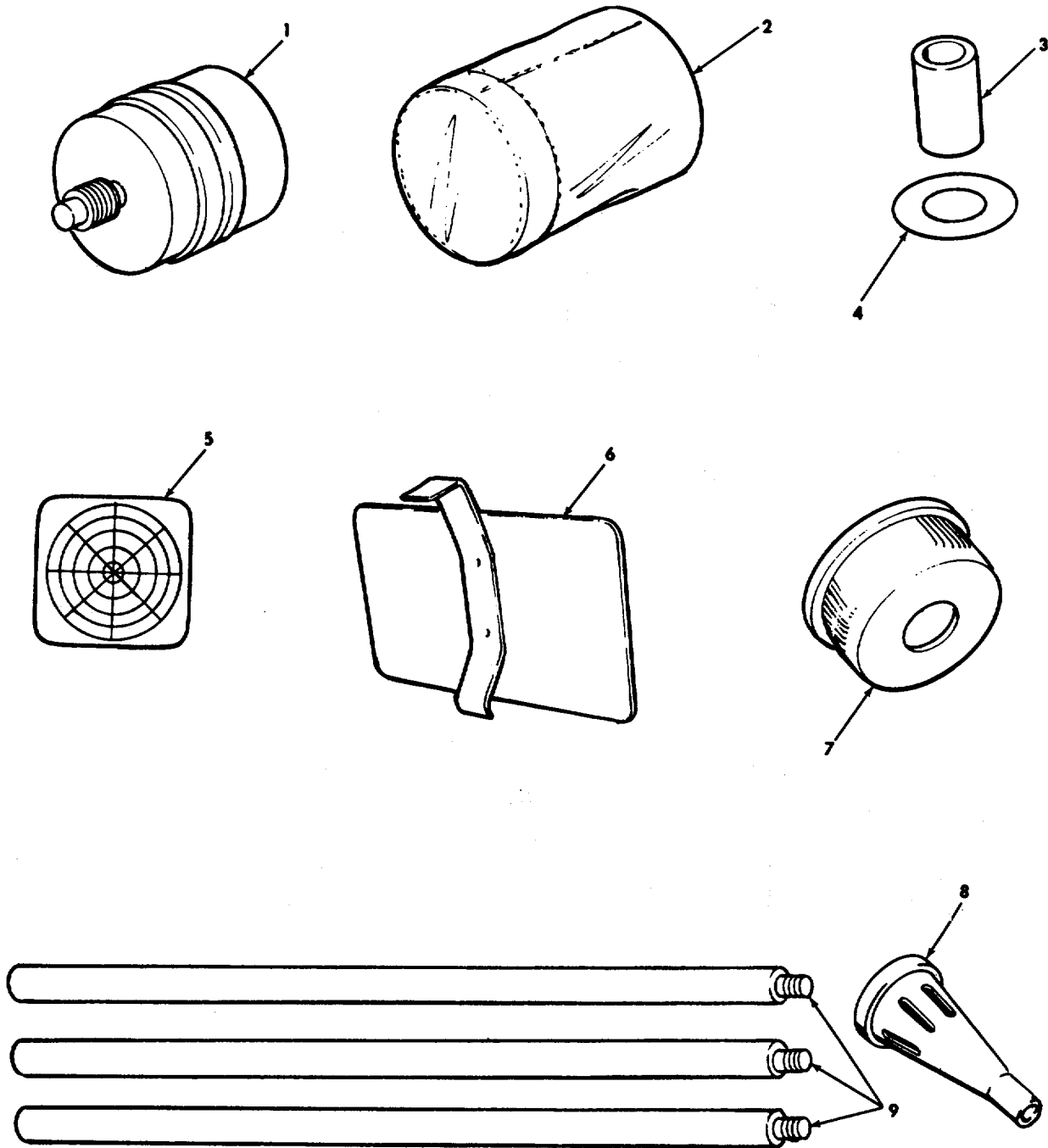

Figure B-1. Basic issue items



WE 12112

Figure B-2. Basic issue items



WE 12113

Figure B-3. Basic issue items



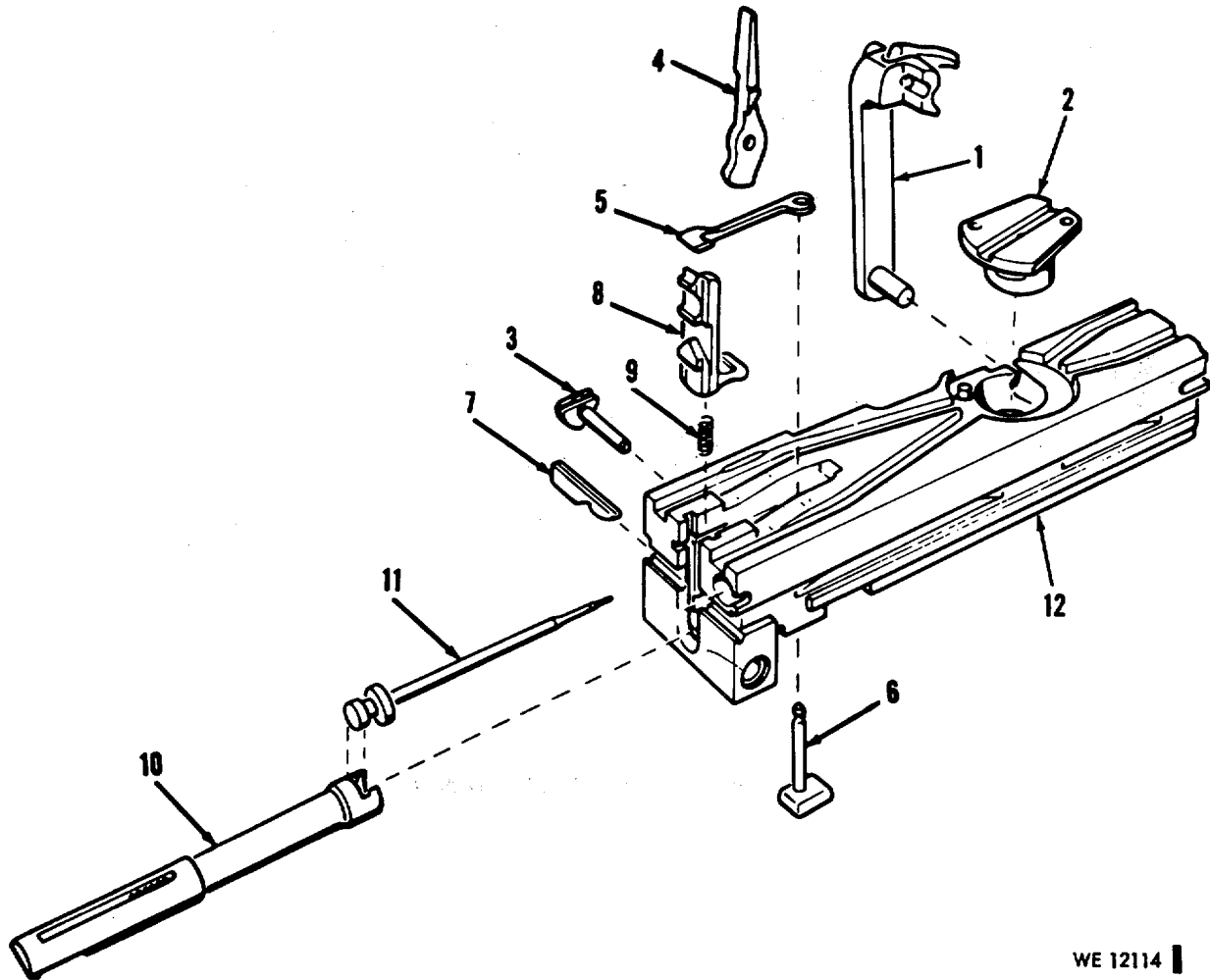

WE 12114

Figure B-4. Basic issue items

B-24

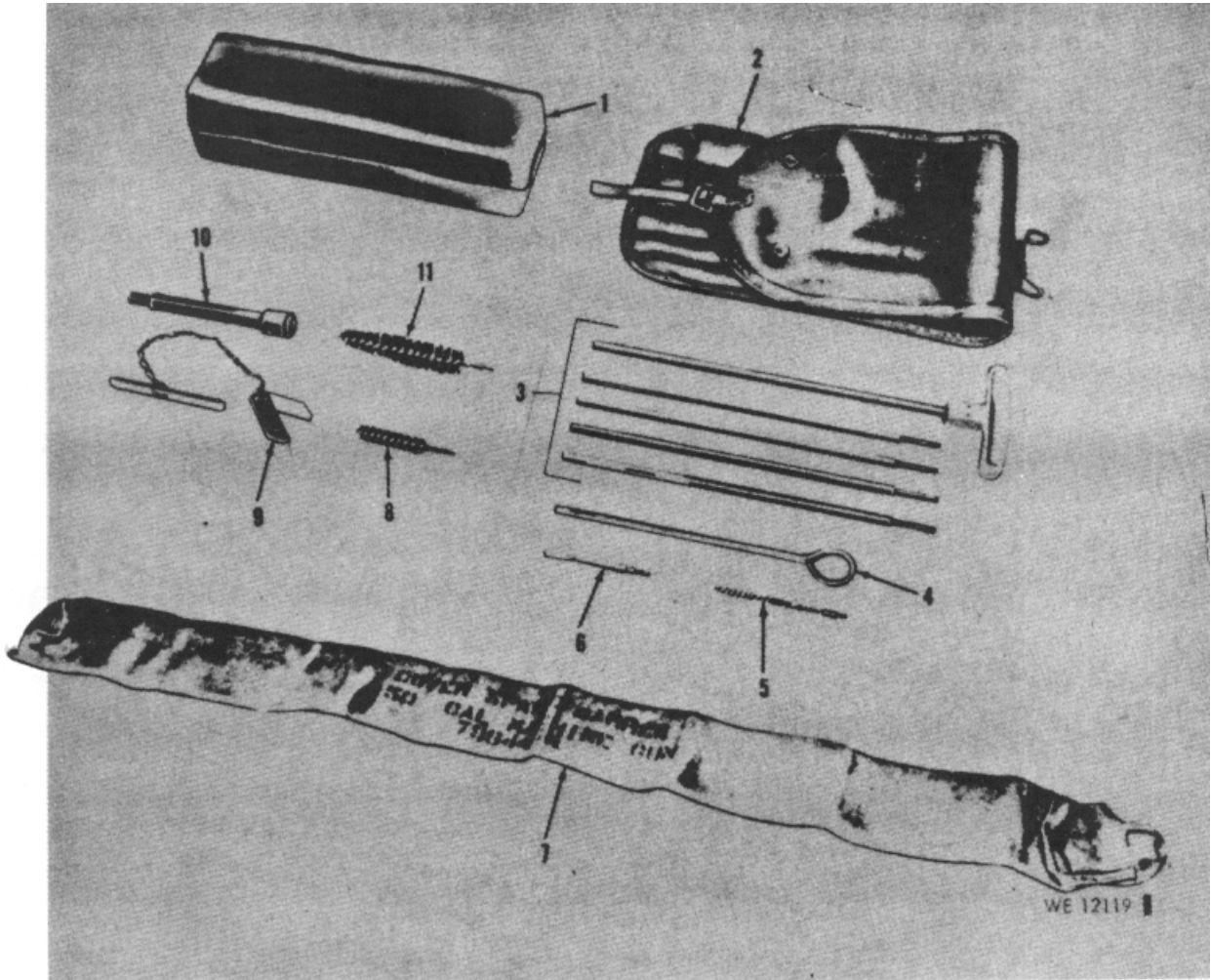

Figure B-5. Basic issue items

B-25

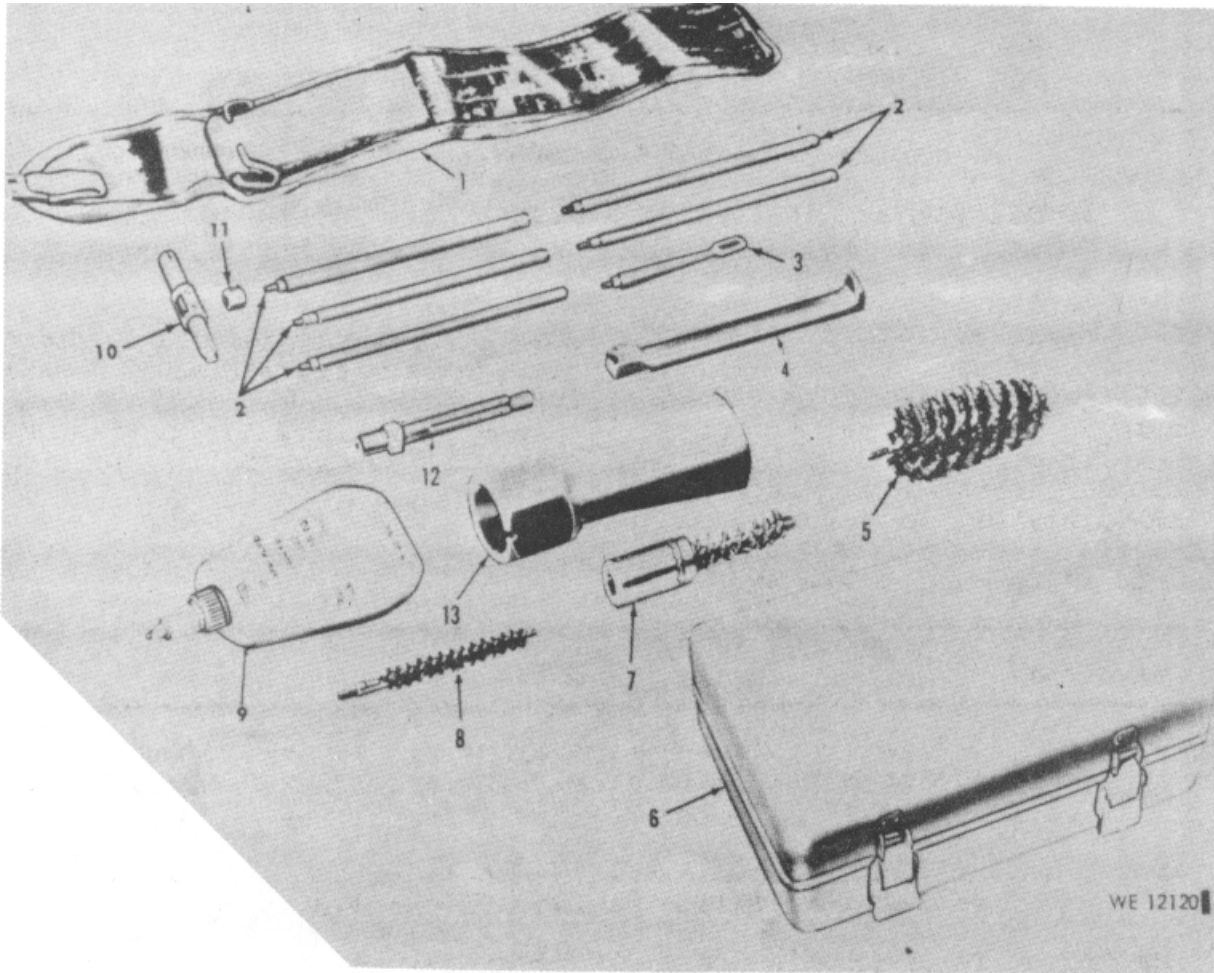
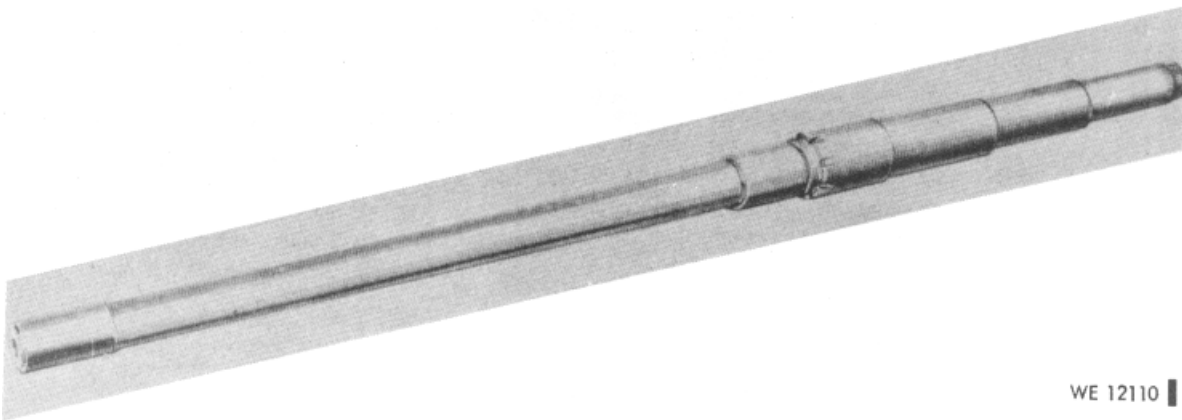

Figure B-6. Basic issue items



WE 12110

Figure B-7. Basic issue items

## APPENDIX III

## MAINTENANCE ALLOCATION CHART

## Section C-1. GENERAL

*NOTE. All references to M551A1 in this appendix pertain to vehicles equipped with laser range finder.*

**C-1. General**

This Maintenance Chart designates overall responsibility for the performance of maintenance functions on the AR/AAV, M551, M551A1, or a component.

The implementation of field maintenance tasks upon this end item or component will be consistent with the assigned maintenance operations in section C-2.

**C-2. Maintenance Functions**

Operation	Definition
INSPECT	To determine serviceability of an item by comparing its physical, mechanical, and electrical characteristics with established standards.
TEST	To verify serviceability and to detect electrical or mechanical failure by use of test equipment.
SERVICE	To clean, to preserve, to charge, to paint, to drain, and to add fuel, lubricants, hydraulic fluids, cooling agents, deicing fluids, and air.
ADJUST	To rectify to the extent necessary to bring into proper operating range.
ALIGN	To adjust specified variable elements of an item to bring to optimum performance.
CALIBRATE	To determine the corrections to be made in the readings of instruments or test equipment used in precise measurement. Consists of the comparison of two instruments, one of which is a certified standard of known accuracy, to detect and adjust any discrepancy in the accuracy of the instrument being compared with the certified standard.

Operation	Definition
INSTALL	To set up for use in an operational environment such as an emplacement, site, or vehicle.
REPLACE	To replace unserviceable items with serviceable like items.
REPAIR	Those maintenance operations necessary to restore an item to serviceable condition through correction of material damage or a specific failure. Repair may be accomplished at each category of maintenance.
OVERHAUL	Normally, the highest degree of maintenance performed by the Army, in order to minimize time work is in process, consistent with quality and economy of operation. It consists of that maintenance necessary to restore an item to completely serviceable condition as prescribed by maintenance standards in technical publications for each item of equipment. Overhaul normally does not return an item to like new, zero mileage, or zero hour condition.
REBUILD	The highest degree of materiel maintenance. It consists of restoring equipment as nearly as possible to new condition in accordance with original manufacturing standards. Rebuild is performed only when required by operational considerations or other paramount factors and then only at the depot maintenance category. Rebuild reduces to zero the hours or miles the equipment, or component thereof, has been in use.

**C-3 Explanation of Format**

**a. Section C-2.**

(1) *Column 1, group number.* Column 1 lists group numbers, the purpose of which is to identify components, assemblies, subassemblies, and modules with the functional group.

(2) *Column 2, functional group.* Column 2 lists the noun names of components, assemblies,

subassemblies, and modules on which maintenance is authorized.

(3) *Column 3, maintenance function.* Column 3 is divided into 11 columns (subcolumns (a) through (k) , one for each of the maintenance operations defined in paragraph C-2.

(4) *Use of symbols.* An uppercase letter placed in the appropriate column indicates

the lowest category at which that particular maintenance function is to be performed.

Code	Explanation
C	Crew/operator
O	Organizational maintenance
F	Direct support maintenance
H	General support maintenance
D	Depot maintenance

(5) *Column 4, tools and equipment.* Column 4 specifies, by code, those tools and test equipments required to perform the designated maintenance of the functional group. The code consists of a number identifying a particular tool or item of test equipment (sec C-3) and a lowercase letter(s) correlating that tool or test equipment with the specific maintenance operation(s) for which it is required (colm 3).

(6) *Column 5, remarks.* Self-explanatory.

b. *Section C-3.*

(1) *Tool or test equipment reference code.* This code consists of a number assigned to each tool or item of test equipment and a letter(s) referencing the maintenance function(s) for which the equipment is required.

(2) *Maintenance category.* The maintenance code specifies the lowest level of maintenance authorized to use the tool or test equipment.

(3) *Nomenclature.* This column lists the name or identification of the tool or test equipment.

(4) *FSN and tool number columns.* The Federal stock number and part or reference number of the tool or test equipment are listed for identification purposes.

(C-2.2 blank)/C-2.1

**SECTION C-2 MAINTENANCE ALLOCATION CHART  
ARMORED RECONNAISSANCE/AIRBORNE ASSAULT VEHICLE: FULL TRACKED, 152 MM, M551**

(1) GROUP NUMBER	(2) FUNCTIONAL GROUP	(3) MAINTENANCE FUNCTIONS											(4) TOOLS AND EQUIPMENT	(5) REMARKS
		A	B	C	D	E	F	G	H	I	J	K		
		INSPECT	TEST	SERVICE	ADJUST	ALIGN	CALIBRATE	INSTALL	REPLACE	REPAIR	OVERHAUL	REBUILD		
0100	GROUP 01 ENGINE POWER PLANT							O					1 (h) (g)	
	MOUNT AND SUPPORT, ENGINE									O				
	ENGINE								F	H				
0101	HEAD, CYLINDER								F	F				
0102	PULLEY, CRANKSHAFT								F					
	SEAL, OIL, CRANKSHAFT								F					
0103	FLYWHEEL								F					
0106	FILTER, OIL, ENGINE			O					O					
	ELEMENT, ENGINE OIL FILTER								O					
	COOLER, OIL, ENGINE								O	F				
	VALVE, (BYPASS)								F	F				
	HOSES, LINES AND FITTINGS								O	F				
	REGULATOR, PRESSURE ENGINE OIL SYSTEM								F					
	HOSE, BREATHER, CRANKCASE								O					
	TANK, AIR BOX/BREATHER			O										

**SECTION C-2 MAINTENANCE ALLOCATION CHART  
ARMORED RECONNAISSANCE/AIRBORNE ASSAULT VEHICLE: FULL TRACKED, 152 MM, M551**

(1) GROUP NUMBER	(2) FUNCTIONAL GROUP	(3) MAINTENANCE FUNCTIONS											(4) TOOLS AND EQUIPMENT	(5) REMARKS	
		A	B	C	D	E	F	G	H	I	J	K			
		INSPECT	TEST	SERVICE	ADJUST	ALIGN	CALIBRATE	INSTALL	REPLACE	REPAIR	OVERHAUL	REBUILD			
0108	CAP, OIL ENGINE								O						
	TUBE AND FITTINGS, DRAIN, AIR BOX								O						
	PAN, OIL, ENGINE								O	F					
	GAGE, DIPSTICK								O						
	SCREEN, OIL, ENGINE								F						
	MANIFOLD, EXHAUST								O						
	0109	0109 QUILL, AIR BLOWER DRIVE								F					
		DRIVE, GEAR, AIR BLOWER								F					
	0301	GROUP 03 FUEL													
		INJECTOR, FUEL SYSTEM								F	H				
TUBES AND FITTINGS, FUEL INJECTOR									F						
0302	LEVER, LINK AND TUBE CONTROL, FUEL INJECTOR				F				F						
	PUMP, FUEL, ENGINE								O	F					
0304	CLEANER, AIR							O		O					
	HOSES AND CLAMPS								O						
	ELEMENT			C					O						



GROUP NUMBER	FUNCTIONAL GROUP	MAINTENANCE FUNCTIONS										TOOLS AND EQUIPMENT	REMARKS		
		(a)	(b)	(c)	(d)	(e)	(f)	(g)	(h)	(i)	(j)			(k)	
0305	TURBOCHARGER AND BLOWER								F	H					
	DUCT, HOSE AND PIPES BLOWER AND TURBOCHARGER								O						
0306	TANK, FUEL									F					
	CAP, FUEL, FILLER								O						
	LINES, HOSES AND FITTINGS, FUEL SYSTEM								F						
	VALVE, SHUT-OFF, FUEL								O						
0308	GOVERNOR				F				F	H					
0309	ELEMENT, FUEL FILTER								O						
	FILTERS, FUEL									O					
0310	AIR BOX (FLAME) HEATER COMPONENTS								O						
	ACCUMULATION, AIR BOX				O				O						
	PUMP, HAND, AIR BOX								O						
	LINES AND FITTINGS								O						
0312	LINKAGE, CONTROL, THROTTLE AND FUEL SHUT-OFF					O				O					

**SECTION C-2 MAINTENANCE ALLOCATION CHART  
ARMORED RECONNAISSANCE/AIRBORNE ASSAULT VEHICLE: FULL TRACKED, 152 MM, M551**

(1) GROUP NUMBER	(2) FUNCTIONAL GROUP	(3) MAINTENANCE FUNCTIONS											(4) TOOLS AND EQUIPMENT	(5) REMARKS
		A	B	C	D	E	F	G	H	I	J	K		
		INSPECT	TEST	SERVICE	ADJUST	ALIGN	CALIBRATE	INSTALL	REPLACE	REPAIR	OVERHAUL	REBUILD		
	GROUP 04 EXHAUST													
0401	MUFFLER AND PIPES								O					
	GROUP 05 COOLING													
0501	RADIATOR								O	F				
	TANK, SURGE AND CAP								O					
0502	SHROUD, RADIATION								O					
0503	PIPES, HOSES AND CLAMPS								O					
	THERMOSTAT								O					
0504	PUMP, COOLANT								O	F				
	BELTS, PUMP	C			O				O					
0505	CLUTCH, FAN, DRIVE								F	H				
	FAN, COOLING								O				2(h)	
	BELTS, FAN	C							O					
	GROUP 06 ELECTRICAL													
0601	GENERATOR								O	F				

GROUP NUMBER	FUNCTIONAL GROUP	MAINTENANCE FUNCTIONS										TOOLS AND EQUIPMENT	REMARKS	
		(a)	(b)	(c)	(d)	(e)	(f)	(g)	(h)	(i)	(j)			(k)
	DRIVE, GENERATOR								O	F				
	TENSIONER, GENERATOR								O					
0602	REGULATOR, VOLTAGE				O				O	F				
0603	STARTER								O	F				
0607	PANEL, SWITCH, DRIVER'S									O				
	PANEL, INDICATOR, DRIVER'S							O		F				
	HARNESS, PANEL								F	O				
	LAMPS								C					
	DRIVE COMPONENTS, TACHOMETER/ODOMOETER								O					
	INSTRUMENTS, INDICATOR PANEL									F				
0608	RELAY, MASTER								O					
	RELAY, STARTER								O					
	SWITCHES								O					
	RELAY BILGE PUMP								O					
	RECEPTACLES								O					

SECTION C-2 MAINTENANCE ALLOCATION CHART														
ARMORED RECONNAISSANCE/AIRBORNE ASSAULT VEHICLE: FULL TRACKED, 152 MM, M551														
(1) GROUP NUMBER	(2) FUNCTIONAL GROUP	(3) MAINTENANCE FUNCTIONS											(4) TOOLS AND EQUIPMENT	(5) REMARKS
		A	B	C	D	E	F	G	H	I	J	K		
		INSPECT	TEST	SERVICE	ADJUST	ALIGN	CALIBRATE	INSTALL	REPLACE	REPAIR	OVERHAUL	REBUILD		
0609	BREAKERS, CIRCUIT LIGHTS LAMP								O	O				
0610	TRANSMITTERS AND SWITCHES								O					
0612	BATTERY			C					O	F				
0613	CABLE, BATTERY HARNESS, GENERATOR REGULATOR TO GENERATOR								O	O				
0614	HARNESS, HULL AND POWER PLANT RING, ELECTRICAL CONTACT <b>SLIP RING, CUPOLA</b> ELECTRICAL								F	O			D	3(b)  4(g), (d), (e)

GROUP NUMBER	FUNCTIONAL GROUP	MAINTENANCE FUNCTIONS										TOOLS AND EQUIPMENT	REMARKS		
		(a)	(b)	(c)	(d)	(e)	(f)	(g)	(h)	(i)	(j)			(k)	
0616	BLOWER, TURRET VENTILATING								O	F					
0618	POWER SUPPLY, TURRET CONTROL		O		F				O				D	5 (b), (d), 98(b), (d)	
	POWER SUPPLY, CONVENTIONAL WEAPONS								O					98 (b) (d)	
	POWER SUPPLY, GRENADE LAUNCHER								O					98(b) (d)	
	BOX, LOADER'S CONTROL								O	F				3(b) 98 (b) (d)	
	BOX, CUPOLA CONTROL								O	F				3(b)	
	BOX, CUPOLA TRAVERSE MECHANISM CONTROL								O	F				3(b)	
	COMMANDER'S CUPOLA TRAVERSE MECHANISM CONTROL BOX ASSEMBLY W/SUPPRESSOR (M551A1 ONLY)								O	F					
	COMMANDER'S CUPOLA/LASER CONTROL ASSEMBLY (M55A1A ONLY)								O	F					
	REMOTE SWITCH ASSEMBLY (M551A1 ONLY)								O	F					
	RESISTOR BOX ASSEMBLY (M551A1 ONLY)								O	F					

**SECTION C-2 MAINTENANCE ALLOCATION CHART  
ARMORED RECONNAISSANCE/AIRBORNE ASSAULT VEHICLE: FULL TRACKED, 152 MM, M551**

(1) GROUP NUMBER	(2) FUNCTIONAL GROUP	(3) MAINTENANCE FUNCTIONS											(4) TOOLS AND EQUIPMENT	(5) REMARKS	
		A	B	C	D	E	F	G	H	I	J	K			
		INSPECT	TEST	SERVICE	ADJUST	ALIGN	CALIBRATE	INSTALL	REPLACE	REPAIR	OVERHAUL	REBUILD			
	SWITCHES & CAMS, LIMIT, ELEVATION AND DEPRESSION				F				F					3(b), 5(b), (d) 98 (b) (d)	
	SWITCH, TRAVERSE INTER-FERENCE		O		F				F					5(d), (b) 98 (b) (d) 3 (b)	
	SWITCH, IN-BATTERY LIMIT		O		O				F					3(b) 98 (b) (d)	
	SWITCH, TRANSMITTER DOOR		O		O				O					3(b), 6(d) 98 (b) (d)	
	BOX, TURRET CONTROL ACCESSORY		O		O				O	F				5(d), (b) 98 (b) (d)	
	PRINTED CIRCUIT BOARDS		O		O				O					5(b), (d) 98 (b) (d)	
	RELAY ASSEMBLY		O						O					5(b), (d) 98 (b) (d)	
	BOX, RELAY WEAPONS		O						O	F				98 (b) (d)	
	BLASTING MACHINE		O						O	F				3(b)	
	SOLENOID, GRENADE LAUNCHER	C			O				O					3(b)	
	BOX, RETICLE DIMMER									F				3(b)	
	POWER SUPPLY, EMERGENCY, TELESCOPE & PERISCOPE								O	F				3(b)	
	CONTROL SELECTOR, GUN AND TURRET									F				3(b) 5 (b) (d) 98 (b) (d)	

GROUP NUMBER	FUNCTIONAL GROUP	MAINTENANCE FUNCTIONS											TOOLS AND EQUIPMENT	REMARKS
		(a)	(b)	(c)	(d)	(e)	(f)	(g)	(h)	(i)	(j)	(k)		
0619	BOX, CIRCUIT CUTOUT								O	F			3(b), 5(b), (d) 98(b), (d)	
	AMPLIFIER INTEGRATOR ASSY		O		O				O	F			5(b), (d) 98 (b) (d)	
	MOTOR GENERATOR ASSEMBLY		O		O				O	F		D	3(b) 98 (b) (d)	
0620	GYRO SELECTOR ASSEMBLY		O						O	F			3(b), 5(b), (d) 98 (b)(d)	
	HARNESS, TURRET & CUPOLA, ELECTRICAL DRIVE, WEAPON & ACCESSORY SYSTEMS								F	F			3(b), 5(b), (d) 98 (b) (d)	
	SPECIAL PURPOSE CABLE ASSEMBLY (M551A1 ONLY)								F	F				
0700	GROUP 07 TRANSMISSION													
	TRANSMISSION								F	H				
	PLUG, OIL DRAIN								O					
0711	BRAKE				O									
	LINKAGE, CONTROL, SHIFT				O				O					
0721	COOLER, OIL, TRANSMISSION								O	F				

**SECTION C-2 MAINTENANCE ALLOCATION CHART  
ARMORED RECONNAISSANCE/AIRBORNE ASSAULT VEHICLE: FULL TRACKED, 152 MM, M551**

(1) GROUP NUMBER	(2) FUNCTIONAL GROUP	(3) MAINTENANCE FUNCTIONS											(4) TOOLS AND EQUIPMENT	(5) REMARKS	
		A	B	C	D	E	F	G	H	I	J	K			
		INSPECT	TEST	SERVICE	ADJUST	ALIGN	CALIBRATE	INSTALL	REPLACE	REPAIR	OVERHAUL	REBUILD			
1206	SEAL, OUTPUT SHAFT								F						
	FILTER, OIL			O					O	F					
1301	INDICATOR, OIL LEVEL								O						
	VALVE, CONTROL								F		F				
	GROUP 12 BRAKE CONTROLS														
	CONTROLS, BRAKE				O				O	O					7 (d)
	GROUPS 13 TRACKS AND SUSPENSION														
	ARM, ROADWHEEL								O	O					8 (h), 9(g), 10 (h) 11 (h), 12 (h), 13 (h)
	HOUSING, ROADWHEEL ARM, FRONT AND REAR								O	F					14 (h), 15 (h), 16 (h), 17 (h)
	HOUSING, ROADWHEEL ARM, INTERMEDIATE								O	O					14 (h), 15 (h), 16 (h), 17 (h)
	BAR, TORSION								O						18 (h)
	ANCHOR, TORSION BAR								O						19 (h)



GROUP NUMBER	FUNCTIONAL GROUP	MAINTENANCE FUNCTIONS											TOOLS AND EQUIPMENT	REMARKS		
		(a)	(b)	(c)	(d)	(e)	(f)	(g)	(h)	(i)	(j)	(k)				
1303	PLUG, SIGHT, OIL									O						
	WHEEL, ROAD									O						
	HOUSING, IDLER, W/SPINDLE									O	O					
	WHEEL, IDLER									O						
	HUB, IDLER WHEEL									O	F				15(h), 11 (h), 20 (h)	
	ADJUSTER, TRACK, HYDRAULIC									O	F					
	PLUG, RELEASE, LUBRICATION AND PRESSURE										O					
	SPROCKET AND WHEEL									O					21(a)	
	SHAFT, DRIVE, SPROCKET									O					22 (h), 23(h), 15(h), 24(h), 17(h), 25(h), 26(h)	
	HUB, SPROCKET									O	O					
1305	SUPPORT, SPROCKET HUB									O						
	TRACK				C			C			O				27 (i), 28 (i)	
GROUP 14 CONTROLS																
1401	LINKAGE, CONTROL ATEER				O						O					
GROUP 15 TOWING SHACKLE																
1503	SHACKLE, TOWING										O					
	GROUP 16 SHOCK ABSORBERS															
	ABSORBERS, SHOCK									O	F					

SECTION C-2 MAINTENANCE ALLOCATION CHART														
ARMORED RECONNAISSANCE/AIRBORNE ASSAULT VEHICLE: FULL TRACKED, 152 MM, M551														
(1) GROUP NUMBER	(2) FUNCTIONAL GROUP	(3) MAINTENANCE FUNCTIONS											(4) TOOLS AND EQUIPMENT	(5) REMARKS
		A	B	C	D	E	F	G	H	I	J	K		
		INSPECT	TEST	SERVICE	ADJUST	ALIGN	CALIBRATE	INSTALL	REPLACE	REPAIR	OVERHAUL	REBUILD		
1801	GROUP 18 HULL													
	SURFBOARD									F				
	CONTROLS, SURFBOARD				O					O				
	BARRIER								F	O				
	HATCH, DRIVER'S ROTATABLE									F				
	LATCHES									O				
1806	SEALS, HATCH								O					
	BACKREST, SEAT, DRIVER'S								O					
	CUSHION, SEAT								O					
	MECHANISM, SEAT, DRIVER'S									O				
1808	BELT, SEAT								O					
	RACKS, AMMNITION STOWAGE									O				
1901	GROUP 19 TURRET													
	TURRET, RACE COMPONENTS								F	F				
	LOCK, TURRET TRAVERSE									O				
	MECHANISM, SEAT									O				
	COMMANDER'S SUBFLOOR, SCREENS								F	F				



SECTION C-2 MAINTENANCE ALLOCATION CHART														
ARMORED RECONNAISSANCE/AIRBORNE ASSAULT VEHICLE: FULL TRACKED, 152 MM, M551														
(1) GROUP NUMBER	(2) FUNCTIONAL GROUP	(3) MAINTENANCE FUNCTIONS											(4) TOOLS AND EQUIPMENT	(5) REMARKS
		A	B	C	D	E	F	G	H	I	J	K		
		INSPECT	TEST	SERVICE	ADJUST	ALIGN	CALIBRATE	INSTALL	REPLACE	REPAIR	OVERHAUL	REBUILD		
1904	MECHANISM,, TURRET TRAVERSE								F	F			30 (d), 31 (d), 32 (d), 33(d) 36(d)	
	MECHANISM, GUN ELEVATION								F	F			34(d), 35(d)	
	HANDLE ASSY, CONTROL, GUNNER'S AND COMMANDER'S				C				O	F			5 (b), (d)	
	SERVOMETER, TRAVERSE AND ELEVATION								O	F			5 (b), (d)	
1906	BOXES, STRAPS AND RACKS, STOWAGE									O				
1907	AMMO BOX, MACHINE GUN								F	O				
	GROUP 22 HULL MISCELLANEOUS ACCESSORIES													
2202	BOX, GROUND, INTERCOM LAMP, INTERCOM BOX									O				

GROUP NUMBER	FUNCTIONAL GROUP	MAINTENANCE FUNCTIONS										TOOLS AND EQUIPMENT	REMARKS		
		(a)	(b)	(c)	(d)	(e)	(f)	(g)	(h)	(i)	(j)			(k)	
2205	PUMP, BILGE								O	F					
	HOSE, CLAMPS AND FITTINGS								O						
2207	HEATER, PERSONNEL								O	H					
	BOX, CONTROL, HEATER								O						
	DUCT, FLEXIBLE								O						
	IGNITER								O						
2210	LAMPS, CONTROL BOX, HEATER								C						
	PUMP, FUEL FILTER, VALVE AND LINES								O						
	PLATE, DATA, VEHICLE								O						

SECTION C-2 MAINTENANCE ALLOCATION CHART														
ARMORED RECONNAISSANCE/AIRBORNE ASSAULT VEHICLE: FULL TRACKED, 152 MM, M551														
(1) GROUP NUMBER	(2) FUNCTIONAL GROUP	(3) MAINTENANCE FUNCTIONS											(4) TOOLS AND EQUIPMENT	(5) REMARKS
		A	B	C	D	E	F	G	H	I	J	K		
		INSPECT	TEST	SERVICE	ADJUST	ALIGN	CALIBRATE	INSTALL	REPLACE	REPAIR	OVERHAUL	REBUILD		
3303	GROUP 33 SPECIAL PURPOSE KITS  KIT, WINTERZATION  KIT, AIR FILTER UNIT							F	O	F				
3401	GROUP 34 ARMAMENT, SIGHTING AND FIRE CONTROL, AND GUIDANCE AND CONTROL MATERIEL  152MM GUN-LAUNCHER, M81, M81 MOD, M81E1 AND MOUNT  MECHANISM GROUP, BREECH ACTUATING			C	F					F				37 (d), (g), 38 (d), (g), 39 (d), (g), 40 (d), (g)



SECTION C-2 - MAINTENANCE ALLOCATION CHART															
ARMORED RECONNAISSANCE/AIRBORNE ASSAULT VEHICLE: FULL TRACKED, 152MM, M551															
(1) GROUP NUMBER	(2) FUNCTIONAL GROUP	(3) MAINTENANCE FUNCTIONS											(4) TOOLS AND EQUIPMENT	(5) REMARKS	
		a	b	c	d	e	f	g	h	i	j	k			
		INSPECT	TEST	SERVICE	ADJUST	ALIGN	CALIBRATE	INSTALL	REPLACE	REPAIR	OVERHAUL	REBUILD			
3402	CONTROL, TRANSMITTER				O				O						
	MOUNT, GRENADE LAUNCHER	C			O				O	F					
	GRENADE LAUNCHER TUBE ASSEMBLY	C			O				O	F					
3403	SMALL ARMS														
	MACHINE GUN, 7.62MM M73/M219 REFER TO TM 9-1005-233-25														
	MACHINE GUN, CAL.. 50 M2 HB, REFER TO TM 9-1005-213-25														
	SIGHTING AND FIRE CONTROL MATERIEL														
	INDICATOR AZIMUTH	C		C					O	F	H				
	MOUNT, TELESCOPE M149 OR M165	C		C		C			O	F		D	55(c), 56(c), 57(c), 58(c), 59(b), 60(a), 61(e), 62(f), 63(c), 64(c), 65(c), 66(d)(e), 67(c), 68(b), 69(c), 70(d), 71(c), 72(g) (h)		
	PERISCOPE, M37	C		C					O	F					
	PERISCOPE, XM44 SERIES	C		C	O				O	F		D	55(c), 56(c), 57(c), 58(c), 73(d), 74(d), 75(d), 76(d), 77(d), 78(h), 79(f), 63(c), 80(e), 65(c), 66(d) (e), 81(d), 67(c), 69(c), 82(a), 83(b), 84(b), 72(g)(h)		
	BATTERY, STORAGE: 6v (emergency)	C		O					O						
	LINK ASSY	C		C	O					F	F				
MOUNT ASSY	C		C						F	F	H				
PANEL ASSY	C		C						F	F					
PLATE ASSY	C		C						O	F					



	FUNCTIONAL GROUP	MAINTENANCE FUNCTIONS										TOOLS AND EQUIPMENT	REMARKS
		(a)	(b)	(c)	(d)	(e)	(f)	(g)	(h)	(i)	(j)		
3405	WASHER, PUMP AND RESERVOIR ASSY	C		C					O	F	H		55(c), 56(c), 57(c), 58(c), 85(b), 63(c), 65(c), 67(c), 68(b), 69(c)
	PERISCOPE, M47	C		C					O		O		
	MOUNT ASSY	C		C					O	F	H		
	SEAL ASSY	C		C					O				
	WASHER, PUMP AND RESERVOIR ASSY	C		C				O	O	H			
	WIPER ASSY	C		C		F			O	H			
	PERISCOPE, M48	C		C					O			D	55(c), 56(c), 57(c), 58(c), 87(d), 85(b), 60(a), 86(d), 77(d), 88(a), 63(c), 65(c), 81(d), 67(c), 68(b), 69(c), 89(b), 90(b), 91(d), 92(g) (h), 71(g) (h)
	HEADREST ASSY	C		C					O				
	QUADRANT, F. C. M13A1C	C		C	O				O	F	H		
	QUADRANT, GUNNER'S M1A1	C		C	F				O	F	H		
	TELESCOPE, M127 OR M119	C		C	C	C			O	O		D	
	HANGER ASSY	C			C				O				
	GROUP 3405 GUIDANCE AND CONTROL SYSTEM												
	POWER SUPPLY	C	C	C	F				O	F	F	D	50(c)(g)(h)
	ELECTRONICS COMPONENTS ASSY	F	F		F				F	D	D	D	
	COUNTDOWN MODULE	F	F						F	F	F	D	

**SECTION C-2 - MAINTENANCE ALLOCATION CHART**  
 ARMORED RECONNAISSANCE/AIRBORNE ASSAULT VEHICLE: FULL TRACKED, 152MM, M551

(1) GROUP NUMBER	(2) FUNCTIONAL GROUP	(3) MAINTENANCE FUNCTIONS											(4) TOOLS AND EQUIPMENT	(5) REMARKS
		A	B	C	D	E	F	G	H	I	J	K		
		INSPECT	TEST	SERVICE	ADJUST	ALIGN	CALIBRATE	INSTALL	REPLACE	REPAIR	OVERHAUL	REBUILD		
	DRIVER MODULE	F		F					F	D	D	D		
	D. C. SUPPLY MODULE	F	F		F				F	D	D	D		
	OUTPUT TRANSFORMER MODULE	F	F						F	F	F	D		
	PRIME POWER FILTER MODULE	F		F					F	F	F	D		
	POWER SUPPLY MODULE	F	F		F				F	D	D	D		
	POWER TRANSISTOR MODULE	F		F					F	F	F	D		
	VOLTAGE REGULATOR MODULE	F		F	F				F	D	D	D		
	SWINGING CHOKE MODULE	F	F						F	F	F	D		
	WIRING HARNESS ASSEMBLY	F	F							F	F	D		
	OPTICAL TRANSMITTER	C	C	C	F	F			O	F	F	D		96(g) (h), 6(d)g(h), 97 (g)(h), 50 (c) (g) (h) (i)
	RETICLE ASSEMBLY	F	F			F			F					
	OPTICS BARREL RETICLE ASSEMBLY	F	F						F	D	D	D		
	OPTICAL INSTRUMENT CELL ASSEMBLY	F	F						F	D	D	D		
	ADJUSTABLE BRACKET ASSEMBLY LH	F	F			F			F					
	ADJUSTABLE BRACKET ASSEMBLY RH	F	F			F	F							
	MIRROR SUBASSEMBLY	F	F	F					F	D	D	D		
	TRANSMITTER STARTER	F	F						F	F	F	D		
	FILTER PANEL	F	F						F	F	F	D		
	OPTICAL TRACKER	C	C	C		F			O	F	F	D		97(g)(h), 6 (d)g(h), 50(g) (h)(c)(i)
	DETECTOR SIGNAL AMPLIFIER	F	F			F			F	F	F	D		

	FUNCTIONAL GROUP	MAINTENANCE FUNCTIONS										TOOLS AND EQUIPMENT	REMARKS	
		(a)	(b)	(c)	(d)	(e)	(f)	(g)	(h)	(i)	(j)			(k)
	OPTICAL TRACKER SUBASSEMBLY	F	F		F				F	F	F	D		
	IRIS AND DETECTOR SUBASSEMBLY	F	F		F				D	D	D	D		
	DETECTOR SUBASSEMBLY	F	F						F	D	D	D		
	MODUALTOR	C	C	C					O	F	F	D	50(c)(g)(h)(i)	
	CHASSIS ASSEMBLY	F	F						F	F	F	D		
	WIRING HARNESS	F	F						F	F	F			
	SIGNAL DATA CONVERTER	C	C	C					O	F	F	D	50(c)(g)(h)(i)	
	REFLECTANCE FILTER ASSEMBLY	F	F							F	F			
	AMPLIFIER ASSEMBLY	F	F							F	F			
	DEMODULATOR ASSEMBLY	F	F							F	F			
	TRACKER FILTER ASSEMBLY	F	F							F	F			
	PROGRAM TIMER ASSEMBLY	F	F							F	F			
	COMMAND GENERATOR ASSEMBLY													
	ERROR AMPLIFIER ASSEMBLY	F	F							F	F			
	TRACKER CONTROL ASSEMBLY	F	F							F	F			
	TEST ACCUMULATOR ASSEMBLY	F	F							F	F			
	ANALOG TEST ASSEMBLY	F	F							F	F			
	TEST DISPLAY ASSEMBLY	F	F							F	F			
	WIRING HARNESS ASSEMBLY	F	F							F	F			
	TEST CHECKOUT PANEL	C	C	C					O	C	F	D	50(c)(g)(h)(i)	
	TEST CHECKOUT PANEL	F	F							F	F	D		
	MODULE BOARD ASSEMBLY	F	F							F	F			
	CONNECTOR ASSEMBLY	F	F	F					F	F	F			
	RATE SENSOR	C	C	C					O	F	F	D	50(c)(g)(h)(i)	

**SECTION C-2 - MAINTENANCE ALLOCATION CHART**  
 ARMORED RECONNAISSANCE/AIRBORNE ASSAULT VEHICLE: FULL TRACKED, 152MM, M551

(1) GROUP NUMBER	(2) FUNCTIONAL GROUP	(3) MAINTENANCE FUNCTIONS											(4) TOOLS AND EQUIPMENT	(5) REMARKS
		A	B	C	D	E	F	G	H	I	J	K		
		INSPECT	TEST	SERVICE	ADJUST	ALIGN	CALIBRATE	INSTALL	REPLACE	REPAIR	OVERHAUL	REBUILD		
	CABLE ASSEMBLIES, GUIDED MISSILE SUBSYSTEM	F	F						F					
	GROUP 40 ELECTRIC MOTORS AND GENERATORS (OTHER THAN ENGINE ACCESSORIES)													
4000	ELECTRIC MOTOR (COMPRESSOR)	O							F	F	H			
4001	ROTOR ASSEMBLY	F							F					
4002	STATOR ASSEMBLY		F		F									
4003	BRUSH HOLDERS, BRUSHES AND HOLDERS	F							F					
4004	VENTILATING SYSTEM: FAN								F					
4007	DRIVE COMPONENTS: SHAFT	F							F					
4014	RESISTORS		F											
4016	RELAY		F						F					

	FUNCTIONAL GROUP	MAINTENANCE FUNCTIONS											TOOLS AND EQUIPMENT	REMARKS	
		(a)	(b)	(c)	(d)	(e)	(f)	(g)	(h)	(i)	(j)	(k)			
	<b>GROUP 42 ELECTRICAL EQUIPMENT</b>														
4206	THERMOSTATIC, AUTOMATIC AND MANUAL CONTROL DEVICES: TIMER, DUMP	F						F							
4209	SIGNALING DEVICES: PRESSURE SWITCH		F					F	H						
4211	POWER RECEPTACLE							F							
4216	MISCELLANEOUS WIRING AND FITTINGS: CABLE ASSY							F	F						
	<b>GROUP 50 PNEUMATIC EQUIPMENT</b>														
5000	AIR COMPRESSOR ASSEMBLY (COMPLETE)	O	F	O					O	F	D				
5001	CRANKCASE, BLOCK, CYLINDER HEAD: CYLINDERS AND HEADS								D						
5002	CRANKSHAFT								D						
	SEAL REAR								F						
5004	PISTONS, CONNECTING RODS AND PLUNGERS: PISTONS AND PLUNGERS								D						
5005	VALVES: VALVES, INTAKE AND EXHAUST								D	D					

**SECTION C-2 - MAINTENANCE ALLOCATION CHART**  
 ARMORED RECONNAISSANCE/AIRBORNE ASSAULT VEHICLE: FULL TRACKED, 152MM, M551

(1) GROUP NUMBER	(2) FUNCTIONAL GROUP	(3) MAINTENANCE FUNCTIONS											(4) TOOLS AND EQUIPMENT	(5) REMARKS
		A	B	C	D	E	F	G	H	I	J	K		
		INSPECT	TEST	SERVICE	ADJUST	ALIGN	CALIBRATE	INSTALL	REPLACE	REPAIR	OVERHAUL	REBUILD		
5006	LUBRICATION SYSTEM:  OIL PUMP STRAINER DIPSTICK RELIEF VALVE			O					F	D				
5007	COMPRESSOR DRIVE:  SHAFT	F							F					
5008	AIR INTAKE:  FILTER	O		O					O					
5009	UNLOADER SYSTEM:  MOISTURE SEPARATOR VALVES: RELIEF								O	F				
	CHECK, BACK PRESSURE	O	F						F					
5010	COMPRESSOR OR COOLING AND HEATING  INTERCOOLERS AND AFTERCOOLER FAN								F					
									F	F				

	FUNCTIONAL GROUP	MAINTENANCE FUNCTIONS											TOOLS AND EQUIPMENT	REMARKS	
		(a)	(b)	(c)	(d)	(e)	(f)	(g)	(h)	(i)	(j)	(k)			
	HEATER, MOISTURE SEPARATOR								F	F					
5015	AIR DISCHARGE SYSTEM: FITTING		O						O						
	GROUP 6700 PRECISION INSTRUMENTS AND SYSTEMS														
6715	TEST SET, ELECTRIC DRIVE CONTROL									F					
	HARNESS, TEST SET								O						
	LAMP, TEST SET								O						
	GROUP 76 FIXED FIRE EXTINGUISHER														
7603	CYLINDER, FIRE EXTINGUISHER			O					O						
	CONTROLS, TUBES AND FITTINGS								O	O					

**SECTION C-3 TOOLS AND TEST EQUIPMENT REQUIREMENTS  
ARMORED RECONNAISSANCE/AIRBORNE ASSAULT VEHICLE: FULL TRACKED, 152MM, M551**

TOOLS OR TEST EQUIPMENT REFERENCE CODE	MAINTENANCE CATEGORY	NOMENCLATURE	FSN	TOOL NUMBER
1 - (h) (g)	0	SLING	4910-907-8990	10954024
2 - (h)	0	WRENCH	5120-907-0698	10954016
3- (b)	O	MULTIMETER	6625-553-0142	.IL-M-4269
4 - (g) (d) (e)	F	FIXTURE, POSITIONING BRUSH HOLDER, CONTACT RING	4933-062-4500	11605044
5 - (b) (d)	O	TEST SET, ELECTRONICS SYSTEM	4933-909-9356	11586473
6 - (d) (g) (h)	O	SOCKET WRENCH ATTACHMENT	5t20-243-1674	GGG-W-641
7 - (d)	O	ADAPTER	5120-906-1051	8355955
8- (h)	O	HANDLE	5120-034-0884	10914196
9- (g)	O	INSTALLER	4910-906-1064	10954367
10 - (h)	O	REPLACER	5120-906-1054	10954007-4
11 - (h)	O	REMOVER AND REPLACER	5120-906-1059	10954003-2
12 - (h)	O	REMOVER AND REPLACER	5120-906-1060	10954003-1
13 - (h)	O	WRENCH	5120-901-4283	10954002-1
14 - (h)	O	PUNCH	5120-910-3738	10954017
15 - (h)	O	REPLACER	5120-906-1057	10954007-1
13 - (h)	O	REPLACER	5120-906-1055	10954007-3
17 - (h)	O	REMOVER ASSEMBLY		11643803
18 - (h)	O	ADAPTER	5120-901-6181	10954004
19- (h)	O	REMOVER	5120-907-0696	10954000
20 - (h)	O	WRENCH	5120-901-4282	10954002-2
21 - (a)	O	GAGE	5210-906-3706	10954023
22 - (h)	O	REPLACER	5120-906-1062	10954006-1



**SECTION C-3 TOOLS AND TEST EQUIPMENT REQUIREMENTS**  
**ARMORED RECONNAISSANCE/AIRBORNE ASSAULT VEHICLE: FULL TRACKED, 152MM, M551**

TOOLS OR TEST EQUIPMENT REFERENCE CODE	MAINTENANCE CATEGORY	NOMENCLATURE	FSN	TOOL NUMBER
23 - (h)	O	REPLACER	5120-906-1063	10954006-2
24 - (h)	O	REPLACER	5120-906-1056	10954007-2
25 - (h)	O	REMOVER AND REPLACER	5120-906-1061	10954005
26 - (h)	O	WRENCH	5120-901-4294	10954002-3
27 - (i)	O	FIXTURE	4910-906-1053	10955739
28 - (i)	O	PIN	5120-678-2795	10861180
29 - (d)	F	WRENCH LOCK NUT TORQUING	4933-687-8507	10942347
30 - (d)	F	WRENCH LOCK NUT TORQUING	4933-687-8504	10942154
31 - (d)	F	WRENCH SPANNER	5120-930-7784	11604983
32 - (d)	F	WRENCH SPANNER	5120-930-7785	11604984
33 - (d)	F	WRENCH SPANNER	5120-930-7783	11604981
34 - (d)	F	WRENCH SPANNER	5120-917-6017	11604985
35 - (d)	O	WRENCH TORQUE	5120-242-3263	GGG-W-686
36 - (d)	O	PLIERS	5120-464-4777	11578314
37 - (d) (g)	F	HOLDER PLANET CARRIER	4933-915-8558	11576798
38 - (d) (g)	F	WRENCH ASSEMBLY	4933-915-8540	11576794
39 - (d) (g)	F	WRENCH ASSEMBLY	4933-915-8559	11576784
40 - (d) (g)	O	WRENCH ASSEMBLY	4933-915-8560	11576797
41 - (g) (h)	F	UNLOCKING TOOL	4933-915-8531	11576774
42 - (g) (h)	F	WRENCH	4933-930-1843	11577250
43 - (g) (h)	O	WRENCH	4933-111-6734	11578063o
44 - (c)	O	PULLER TOOL	4933-117-9351	11578228
45 - (a) (g) (i)	O	SERVICING TOOL	4933-464-4776	11578313

**SECTION C-3 TOOLS AND TEST EQUIPMENT REQUIREMENTS  
ARMORED RECONNAISSANCE/AIRBORNE ASSAULT VEHICLE: FULL TRACKED, 152MM, M551**

TOOLS OR TEST EQUIPMENT REFERENCE CODE	MAINTENANCE CATEGORY	NOMENCLATURE	FSN	TOOL NUMBER
46 - (c) (h)	O	WRENCH SPANNER	5120-915-8572	11577226
47 - (h)	F	CRIMPING TOOL TERMINAL	5120-928-3801	11602938
48 - (c)	F	EXTRACTOR CONTACT ELECTRICAL	4933-929-0850	11602937
49 - (c)	F	EXTRACTOR CONTACT ELECTRICAL	4933-929-0849	11602936
50 - (c) (g) (h) (i)	O	PLIERS ELECTRICAL	5120-624-8065	AT508K
51 - (c) (h)	O	ADAPTER	5120-227-8088	GGG-IW-641
52 - (c) (h)	O	SOCKET, SOCKET WRENCH	5120-261-2823	MS16253-34
53 - (c) (h)	O	SOCKET, WRENCH ATTACHMENT	5120-683-8597	GGG-VW-641
54 - (d) (g) (h)	F	ADAPTER TORQUE WRENCH	5120-915-8568	10954930
55 - (c)	F	ADAPTER GUN	4930-765-8128	7648128
56 - (c)	F	ADAPTER GUN	4930-764-8129	7648129
57 - (c)	F	ADAPTER GUN	4930-764-8130	7548130
58 - (c)	F	ADAPTER GUN	4J00-7;4-8v1.]	7648131
59 - (b)	D	ADAPTER, VIBRATOR USED W/VIBRATOR MACHINE 1240-924-8387 for MOUNT M149		11732135
60 - (a)	D	COLLIMATOR PROJECTOR	4931-757-3291	7573291
61 - (e)	F	FIXTURE, DOUBLE COLLIMATOR HOLDING W/CASE FOR MOUNT M149 MODIFIED DOUBLE COLLIMATOR 4931-561-0798		11732248
62 - (f)	D	FIXTURE FINAL TEST	4931-929-8385	10547192
63 - (c)	D	FIXTURE PRESSURE TEST	4931-065-2018	8565556
64 - (c)	F	GUN SEALING COMPOUND HAND	4931-764-8117	7648117
65 - (c)	F	GUN SEALING COMPOUND HYDRAULIC	4931-764-8134	7648134
66 - (d) (e)	H	COLLIMATING FIXTURE W/CASE		11728553
67 - (c)	O	KIT PURGING	4931-065-1110	SC4931-95-CL-J54

**SECTION C-3 TOOLS AND TEST EQUIPMENT REQUIREMENTS**  
**ARMORED RECONNAISSANCE/AIRBORNE ASSAULT VEHICLE: FULL TRACKED, 152MM, M551**

<b>TOOLS OR TEST EQUIPMENT REFERENCE CODE</b>	<b>MAINTENANCE CATEGORY</b>	<b>NOMENCLATURE</b>	<b>FSN</b>	<b>TOOL NUMBER</b>
68 - (b)	D	MACHINE, VIBRATOR	4931-00-929-8387	10547947
69 - (c)	O	NITROGEN TANK (CYLINDER)	6830-00-292-0131	MS56830-9
70 - (d)	F	RADIOMETER TEST SET W/CASE 11730875		
71 - (c)	C	SCREWDRIVER	5120-00-809-1570	GGG-S-121
72 - (g) (h)	F	WRENCH SET, SPANNER	5120-00-580-0012	SC 4931-95-CL1 J52
73 - (d)	D	ADAPTER TORQUE	4931-00-045-4363	10549921
74 - (d)		(Deleted)		
75 - (d)	D	ADAPTER TORQUE	4931-00-045-4360	10549918
76 - (d)	D	ADAPTER TORQUE	4931-00-045-4362	10549920
77 - (d)	D	DIOPTOMETER	4931-00-536-5557	7680631
78 - (h)	F	FIXTURE ASSEMBLY	4931-00-493-9233	11727601
79 - (f)		(Deleted)		
80 - (e)	F	GAGE SPACER	4931-00-947-3059	8566948
81 - (d)	D	HOLDER TELESCOPE	4931-00-612-1110	6121110
82 - (a)	D	TEST SET, FINAL, PERISCOPE	4931-00-156-9920	A. O. 7150
83 - (b)	F	TEST SET, PERISCOPE	4931-00-184-9878	11727677
84 - (b)		(Deleted)		
85 - (b)	D	ADAPTER VIBRATION	4931-00-466-2003	10549681
86 - (d)	D	COLLIMATOR TELESCOPE	4931-00-554-9108	5549108'
87 - (d)	D	ADAPTER	4931-00-909-3144	8566741
88 - (a)	D	FIXTURE FINAL INSPECTION	4931-00-868-8402	10527436
89 - (b)	D	POWER SUPPLY	4931-00-536-5556	7561204

**SECTION C-3 TOOLS AND TEST EQUIPMENT REQUIREMENTS**  
**ARMORED RECONNAISSANCE/AIRBORNE ASSAULT VEHICLE: FULL TRACKED, 152MM, M551**

<b>TOOLS OR TEST EQUIPMENT REFERENCE CODE</b>	<b>MAINTENANCE CATEGORY</b>	<b>NOMENCLATURE</b>	<b>FSN</b>	<b>TOOL NUMBER</b>
90 - (b)	D	ADAPTER, TUBE TESTER	4931-00-053-3644	8566309
91 - (d)	D	TRANSFOR.MER POU'ER SUPPLY	5950-00-243-4136	7284975
92 - (g) (h)	D	U'RENCH SPANNER	5120-00-561-0854	8284044
93 - (b)	D	ADAPTER VIBRATION	4931-00-027-2596	10549922
94 - (a)	D	FIXTURE FINAL INSPECTION	4931-00-929-8383	8570164
95 - (g)	F	WRENCH SPANNER	5120-00-595-8996	7597708
96 - (g) (1))	O	SOCKET WRENCH ATTACHMENT	5120-00-596-0934	GGG-W-641
97 - (,) (h)	O	SOCKET WRENCH ATTACH.MENT SOCKET HEAD SCREW	5120-00-596-8508	GGG-W-641
98-(b)(d)	O	TEST SET, TURRET ELECTRICAL, FAULT ISOLATION	4933-00-432-7269	11678960
<b>C-28</b>				

INDEX

**NOTE.** This Index has been revised in its entirety.

A	PAGE NO.		B	PAGE NO.	
	Oper. Crew	Org. Maint.		Oper. Crew	Org. Maint.
Accelerator/Throttle Control .....	2-8	9-42	Ballistic Shield (Commander's).....	2-32.2	10-36.2
Access Doors, Battery and Air Cleaner .....	5-10	9-125	Basic-Issue (OEM) Items .....	B-1	
Access Plugs, Hull. ....	5-18		Batteries, Vehicle Access Door .....	5-10	9-146.2
Accessory Box, Turret Control.....		10-3	Service and Maintenance .....	5-12	9-90
Accessory Outlet Receptacle .....	2-10		Battery, XM44 Series Periscope .....	5-22.1	
	2-15		Belt Tensioner, "V" .....	5-9	9-90
Accumulator, Air Box Flame Heater.....	2-21	9-13	Bilge Pumps .....	2-20.1	9-125
Accumulator Pressure Gage.....	2-21	9-13	Blasting Machine (Impulse Generator).....	3-7	10-17
Adhesives, Application.....	8-1		Boresighting. ....	2-35	
Adjuster, Track Hydraulic .....	5-13	9-66	Brakes, Parking and Service .....	2-10	9-42
Air Box Heater and Components.....	9-13		Break-In-Services .....	2-6	
Air Cleaner, Engine.....	5-9	9-13	Breather Drain Collector, Engine .....		9-13
Air Delivery (Preparation) .....	6-1		Breech Assembly and Components.....	3-5	11-1
Air Filter Unit (M8A3) .....	2-24	10-29	Breech Electric Drive Motor.....	11-1	
Air Pressure Gage (CBS) . ....	3-8. 4	10-20.1	Breech Electric Drive Solenoid . ....	11-1	
Ammunition Missile .....	7-1		Brush, Elevating and Traverse Mechanism.....		10-3
Conventional .....	7-4.1		Buffer, Counterrecoil .....	5-23	11-1
Ammunition and Missile Stowage Racks:			Bulkhead Access Panel.....	4-13	
Hull .....	3-9	9-125	<b>C</b>		
Turret.....	3-9	10-36.2	Cable Assembly, Missile Subsystem .....		10-20.4
Ammunition Feed System, Machine Gun, 7. 62MM . ....	3-12	10-36.2	Cables, Control.....		9-65
Amphibious Operation .....	2-15		Carrier Cover Vent Plug .....		11-1
Amplifier Integrator Assembly.....		10-3	Check Valve (CBS).....		11-1
Anchor, Torsion Bar.....		9-66	Checkout Panel, Missile Subsystem.....	2-48	10-20.4
Antenna, Radio (Front and Rear) .....	7-6	10-29	Circuit Breaker, Hull .....		9-90
Antifreeze.....	1-2	9-14	Circuit Cutout Box.....		10-29
Armament Maintenance.....	5-23	11-1	Closed Breech Scavenging System:		
		11-25	Description .....	3-4	
Auxiliary Power (Slave) Receptacle .....	2-10	9- 90	Operation .....	3-8.3	
Azimuth Indicator: Data .....	1-3		Maintenance and Service.....	4-8	8-85
Operation.....	2-43				11-10.2
Maintenance.....	2-44	11-32	Commander's Ballistic Shield .....	2-32.2	10-36.2
			Commander's Control Handle.....	2-32.1	10-3

	PAGE NO.	
	Oper. Crew	Org. Maint.
<b>C - Continued</b>		
Communications Equipment .....	7-5.	
Compressor (CBS) .....	3-8.3	10-18.2
Contact Ring, Turret Electrical .....		10-29
Contamination Shield, Radiator .....		9-125
Control Assembly, Cupola .....	2-33	10-29
Control Box Assembly Personnel Heater .....	2-27	9-90
Control Box, Cupola.....	2-33	10-29
Control Box, Loader's .....	3-5	10-17
Control Cables .....		9-65
Control Handles Commander's .....	2-32.1	10-3
Gunner's .....	2-31	10-3
Conventional Weapons Relay Box .....		10-17
Cooling System (Engine) .....	5-9	9-13
Cupola Operation.....	2-33	
Cupola Operation, Manual.....	2-35	
<b>D</b>		
Data, Tabulated .....	1-1	
Debris Screens .....		9-125
Depression Control, Gun- Launcher .....		10-3
Deprocessing Vehicle .....	2-1	
Description of Vehicle .....	1-1	
Photographs, Overall.....	1-4	
Destruction of Materiel.....	6-4	
Detent and Trigger Lever, Ammunition .....	3-7	11-1
Dimmer Switch, Driving Lights .....	2-13	9-90
Dipstick Engine .....	5-11	
Transmission .....	5-11	9-42
Compressor .....	3-2.4	10-18.2
Dome Lights .....	2-10	9-90
Door, Transmitter Cover Operation.....	2-48.1	
Maintenance .....	5-21	10-20. 4
Drain Plugs, Power Plant.....	5-18	
Draining Fuel System .....	5-17	
Coolant System .....	5-17	
Drive Control, Turret Electrical.....	2-29	10-3
Driver's Controls .....	2-10	
Driver's Indicator Panel.....	2-14	9-90

	PAGE NO.	
	Oper. Crew	Org. Maint.
<b>D - Continued</b>		
Driver's Switch Panel.....	2-15	9-90
Driving .....	2-7	
Driving Lights: Operation .....	2-13	
Maintenance .....	5-15	9-90
Dust Shield .....		11-1
<b>E</b>		
Electrical Cable Terminals and Connectors.....		9-91
Electrical Maintenance Hull and Power Plant.....		9-90
Turret and Cupola .....		10-1
Electrical Plug and Receptacle. ....		9-91
Elevating Mechanism .....	2-29	10-3
Elevation and Depression Bump Stops .....		10-3
Elevation Quadrant, M13AIC: Operation .....	2-43	
Maintenance .....	2-45	11-32
Engine and Components Data .....	1-2	
Replacement.....		9-2
Maintenance.....	5-9	9-13
Mount Assembly.....		9-13
Evacuator (Bore) .....	5-22.2	11-1
Exhaust System, Engine .....		9-13
<b>F</b>		
Fan Lockup.....	5-11	
.....	2-14	
Filters; Fuel (Engine).....	5-9	9-13
Oil (Engine) .....		9-13
Fuel Tank Filler .....		9-13
Personnel Heater Fuel.....		9-125
Recoil Mechanism Reservoir.....		11-9
Transmission Oil .....		9-42
Fire Control Operation .....	2-35	
Firing Probe Assembly .....		11-1
Checking Continuity .....	4-11	
Firing Procedures .....	3-1	
Fire Extinguisher Fixed .....	2-10	9-125
Portable .....	2-28	
Flotation Skin Repair .....		9-125

	PAGE NO.	
	Oper. Crew	Org. Maint.
<b>F - Continued</b>		
Forms, Records and Reports.....	1-1	
Fuel Data .....	1-2	
Fuel Filter Inspection .....	2-3	
Fuel Level Transmitter .....		9-91
Fuel Pump, Personnel Heater .....		9-125
Fuel Shut-off Controls.....	2-10	9-13
Fuel System, Engine.....	5-9	9-13
<b>G</b>		
Generator and Drive Assembly.....		9-90
Generator Voltage Regulator .....		9-90
Grenade Launcher, M176 .....	3-24	11-25
Grenade Launcher Guard Kit .....		12-2
Ground Intercom Access Door.....	7-8	9-147
Gun and Turret Control Selector .....	2-42.2	
Gun-Launcher and Components:		
Data .....	1-2	
Operation .....	3-5	
Maintenance .....	5-23	11-1
Gun-Launcher Tube.....		11-1
Gunner's Controls and Instruments .....	2-31	
Gunner's Control Handle .....	2-31	10-3
Gunner's Leg Guard.....		10-36.2
Gyro Selector Assembly Electric Drive .....		10-3
<b>H</b>		
Hatch Cover, Loader's .....	2-32	10-36.2
Hatch, Driver's Escape .....	2-11	9-125
Hatch, Driver's Rotatable:		
Operation.....	2-10	
Maintenance.....		9-125
Headlights:		
Operation.....	2-13	
Maintenance .....	5-15	9-90
<b>I</b>		
Idler Housing and Spindle Assembly.....		9-66

	PAGE NO.	
	Oper. Crew	Org. Maint.
<b>I - Continued</b>		
Idler Hub Assembly .....		9-66
Idler Wheels, Track .....		9-66
Igniter, Personnel Heater .....		9-125
Indicator Panel, Driver's:		
Operation .....	2-14	
Maintenance .....	5-15	9-90
Indicator, Safe to Fire .....	3-8	
Intercom Box Door Assembly, Ground.....	7-8	9-147
Intercommunication Equipment.....	7-5	
<b>L</b>		
Lamps, Spare:		
Hull.....	5-15	
Turret .....	5-19	
Basic Issue .....	B-4	
Land Steer Control Cable and Linkage.....		9-42
Less-Missile Kit .....		12-2
Loading, Firing and Unloading:		
152MM Gun-Launcher .....	3-4	
Cal.. 50 Machine Gun .....	3-14	
7. 62MM Machine Gun.....	3-10.2	
M176 Grenade Launcher.....	3-24	
Loading Tray Bracket Assembly.....		11-1
Loading Tray and Ejector .....	3-7	11-1
Lubrication Order .....	D-1	D-1
<b>M</b>		
Machine Gun, Cal.. 50, M2:		
Data.....	1-3	
Operation .....	3-14	
Maintenance.....	5-23	11-25
Machine Gun, 7. 62MM, M73:		
Data.....	1-3	
Alignment .....	2-40	
Operation .....	3-10.2	
Maintenance .....	5-23	11-25
Machine Gun, M73E1 - Redesignated M219		
Machine Gun, 7. 62MM, M219:		
Data .....	13-1	
Alignment .....	2-40	
Operation .....	3-10.2	
Maintenance .....	13-1	

	PAGE NO.	
	Oper. Crew	Org. Maint.
<b>M - Continued</b>		
Maintenance .....		8-1
Hull and Suspension. ....	5-9	9-1
Turret and Cupola.....	5-19	10-1
		10-3
		10-17
		10-20.4
		10-29
		10-36.2
Armament.....	5-23	11-1
		11-25
Sighting and Fire Control.		11-32
Maintenance Allocation		
Chart .....	C-1	C-1
Maintenance, Preventive .....	4-1	8-75
Master Relay .....		9-90
Mine Protective Kit.....		12-2
Misfire, Hangfire, and Cookoff.....	3-1	
Missile, Guided:		
Identification .....	7-4	
Inspection .....	7-4	
Service Upon Receipt of Materiel .....	7-2	
Missile Inspection Points .....	7-3	
Missile Subsystem:		
Data .....	1-3	
Operation .....	2-48	
Maintenance.....	5-19	10-20.4
Modulator .....	2-48	10-20.4
Motor-Generator .....		10-3
Mount and Components, Gun-Launcher .....	5-23	11-1
Mount, 7. 62MM Machine Gun Alignment .....	2-40	
Maintenance.....		11-1
Mount, Driver's Periscope M47 and .....		11-32
Mount, Loader's Periscope M37 .....		11-32
Mount, Gunner's Telescope M149.....		11-32
<b>N</b>		
Neutral Safety Switch .....		9-42
.....		9-90
Night Vision Sight .....	2-46	
<b>O</b>		
Obturator Seal .....	5-24	11-1
Index-4		

	PAGE NO.	
	Oper. Crew	Org. Maint.
<b>O - Continued</b>		
Oddment Stowage Box.....		10-36.2
Oil Cooler Cores		
..... Engine and Transmission .		9-13
Oil Level Indicator		
Engine .....	5-11	
Transmission .....	5-11	9-42
Compressor.....	3-2.4	10-18.2
Operation		
152MM Gun-Launcher .....	3-4	
Cal. 50 Machine Gun .....	3-14	
7. 62MM Machine Gun .....	3-10.2	
M176 Grenade Launcher .....	3-24	
Optical Tracker .....	2-48	10-20.4
Optical Transmitter Cover and Door .....	2-51	10-20.4
<b>P</b>		
Painting and Stenciling .....		8-1
Panel		
Grenade Launcher Control.....	3-29	10-29
Driving Light Switch.....	2-13	
Indicator, Driver's .....	2-14	9-90
Switch, Driver's.....	2-15	9-90
Test Checkout .....	2-52	10-20.4
XM44 Series Periscope Control.....	2-42	2 11-32
Periscope, Driver's M47		
Data .....	1-3	
Operation .....	2-10	
Maintenance .....	5-19	11-32
Periscope, Driver's M48		
Data .....	1-3	
Operation .....	2-12	
Maintenance.....		11-32
Periscope, Gunner's XM44 Series		
Data.....	1-3	
Operation .....	2-36	
Maintenance.....		11-32
Periscope - Loader's, M37.....	2-32	11-32
Periscope Washers .....	2-12	11-32
Personnel Heater: .....	2-27	9-125
Pintle Support.....		10-36.2
Platform, Commander's .....	2-32	10-36.2
Power Plant		
Data .....	1-2	
Maintenance .....	5-9	9-1
Replacement .....		9-2
Power Supply, Grenade Launcher .....		10-29



	PAGE NO.	
	Oper. Crew	Org. Maint.
<b>P - Continued</b>		
Power Supply, Missile Subsystem .....		10-20.4
Power Supply, 120V Firing Circuit .....		10-17
Power Supply, Turret Control .....	2-51	10-3
Preventive -Maintenance Services .....	4-1	8-75
Prevailing Torque .....		11-1
Protective Pad-Gunner's Leg guard .....		10-36.2
Pump:		
Accumulator, Air Box Heater .....	2-21	9-13
Bilge .....	2-20.1	9-125
Coolant, Engine .....		9-13
Fuel, Engine .....		9-13
Fuel Tank Condensation Drain .....	5-12	9-23
Heater, Personnel .....		9-125
Recoil Mechanism, Gun-Launcher .....	3-8	11-1
XM44/Series Periscope Washer .....	2-42.2	11-32
M47/48 Periscope Washer .....	2-12	11-32
<b>Q</b>		
Quadrant, M1A1 and M13AC .....	2-45	11-32
<b>R</b>		
Radiator Cleaning Kit .....	4-12	10-18.1
Radiator, Engine Coolant .....		9-13
Radio Sets AN/VRC (Basic Units) .....	7-5	
Rate Sensor .....	2-51	10-20.4
Recoil Mechanism, Gun-Launcher, 152MM:		
Guard and Screen .....		11-1
Hydraulic Fittings .....		11-1
Hydraulic Hand Pump .....	3-8	11-1
Reservoir .....	3-8	11-1
Adjustment .....	3-8	
Regulator, Voltage .....		9-90
Relays		
Bilge Pump .....		9-90
Master .....		9-90
Starter .....		9-90
Relay Box, Weapons .....		10-17

	PAGE NO.	
	Oper. Crew	Org. Maint.
<b>R -Continued.</b>		
Reticle Dimmer Box .....	2-41	
2-42		
Road Wheels .....		9-66
Road Wheel Arms .....		9-66
Road Wheel Arm Housing .....		9-66
Road Wheel Arm Spindle .....		9-66
<b>S</b>		
Safety Precautions .....	1-6	
Scavenger System (CBS) .....	3-8. 3	11-1
Seal, Driver's Hatch .....		9-125
Searchlight Kit		
Installation .....	2-57	
Operation .....	2-59	
Seat Commander's .....	2-32	10-36.2
Seat, Driver's .....	2-10	9-125
Seat, Gunner's .....	2-32	10-36.2
Seat, Loader's .....	2-32	10-36.2
Servo Motors, Elevating and Traversing .....		10-3
Shock Absorber .....		9-66
Signal Data Converter .....	2-51	10-20.4
Special Tools and Equipment .....	B-8	8-1
.....	C-24	C-24
Special Tools, Suspension .....		9-66
Speedometer Drive .....		9-91
Spent Brass Chute and Bag, 7. 62MM Machine Gun .....	3-13	11-1
Spindle, Road Wheel Arm .....	9-66	
Sprocket Drive Shaft .....	9-66	
Sprocket Hub and Support .....	9-66	
Sprocket and Sprocket Carrier Wheels .....	9-66	
Starter, Engine .....	9-90	
Starting		
Normal .....	2-7	
Cold Feather .....	2-20.2	
With Auxiliary Power .....	2-22	
By Towing .....	2-22	
Steer Controls and Linkage .....		9-42
Storage .....	6-3	
Stowage .....	B-4	9-125
.....		10-36.2
Surfboard and Barrier .....	2-18	9-125
Surge Tank .....	5-11	9-13
Switches:		
Azimuth Indicator .....		11-32
Engine Pressure .....		9-90
Engine Temperature .....		9-90

	PAGE NO.	
	Oper. Crew	Org. Maint.
<b>S - Continued</b>		
Switches:- Continued		
Gun-Launcher Breech Limit.....		11-1
In-Battery.....		11-1
Neutral Safety.....		9-90
Personnel Heater Flame Detector.....		9-141
Safe-To-Fire Indicator.....	10-17	1
Transmission Pressure.....		9-90
Transmission Temperature.....		9-90
Transmitter Cover Door.....		10-20
Water Steer.....		9-90
<b>T</b>		
Tachometer Drive.....	9-91	
Taillights.....	5-15	9-90
Telescope, M119, M127		
Data.....	1-3	
Operation.....	2-36	
Maintenance.....	5-19	11-32
Telescope Shield.....	10-36.2	
Tensioner, "V" Belt.....	5-11	9-90
Terminals and Connectors.....		9-91
Test Checkout Panel.....	2-52	
Test Set, Electric Drive Control.....		10-3
Throttle/Accelerator Controls.....		9-42
Tools		
Basic Issue.....	B-5	
Special.....	B-8	8-1
.....	C-24	C-24
Improvised.....	8-1	
Pioneer.....	B-7	
Torque, Prevailing.....		11-1
Torsion Bars and Road Wheel Arms.....		9-66
Tow Bar or Tow Cables.....	2-23	
Towing.....	2-22	
Track.....	5-13	9-66
.....	5-14	
Tracker, Optical.....	2-51	10-20.4
Transmission		
Data.....	1-2	
Oil Pressure Check Points.....		8-9
Tests.....		8-10
Replacement.....		9-2

	PAGE NO.	
	Oper. Crew	Org. Maint.
<b>T - Continued</b>		
Transmission - Continued		
Shift Control.....	2-10	9-42
Controls and Linkage.....		9-42
Internal Brake.....		9-42
Oil Filter.....		9-42
Oil Level Indicator.....	5-11	9-42
Transmitter, Optical.....	2-51	10-20.4
Traverse Lock, Turret.....	2-32	10-36.2
Traverse Mechanism, Cupola.....	2-33	
Traversing Mechanism, Turret.....	2-29	10-3
Troubleshooting.....	5-1	8-8
Electrical.....		8-45
Turret Floor Access Cover.....	4-10	10-36.2
Turret Operation.....	2-29	
Turret Stowage		
Exterior.....		10-36.2
Interior.....		10-36.2
<b>V</b>		
Valve, Fuel Tank Shut-Off.....	5-12	9-13
Vehicle Operation.....	2-7	
Vent Plug, Carrier Cover.....		11-1
Ventilating Fan, Turret.....	2-32	10-29
Vision Blocks, Cupola.....	2-34	10-36.2
Voltage Regulator.....		9-90
<b>W</b>		
Washer, Periscope.....	2-12	11-32
Water Steer.....	2-10	9-42
Winterization Kit		
Operation.....	2-53	
Troubleshooting.....		8-28
Electrical Troubleshooting.....		8-66
Maintenance.....		12-1

By Order of the Secretary of the Army:

HAROLD K. JOHNSON,  
*General, United States Army,*  
*Chief of Staff*

Official:

J. C. LAMBERT,  
*Major General, United States Army,*  
*The Adjutant General.*

Distribution:

To be distributed in accordance with DA Form 12-37 requirements for Organizational 'enance, Armored Reconnaissance Airborne Assault Vehicle 152-mm, XM551.

\*U.S. GOVERNMENT PRINTING OFFICE : 1986 0-491-421/40007

RECOMMENDED CHANGES TO EQUIPMENT TECHNICAL PUBLICATIONS



THEN... JOT DOWN THE DOPE ABOUT IT ON THIS FORM, CAREFULLY TEAR IT OUT, FOLD IT AND DROP IT IN THE MAIL!

**SOMETHING WRONG WITH THIS PUBLICATION?**

FROM: (PRINT YOUR UNIT'S COMPLETE ADDRESS)

DATE SENT

PUBLICATION NUMBER

PUBLICATION DATE

PUBLICATION TITLE

BE EXACT... PIN-POINT WHERE IT IS

PAGE NO.

PARA-GRAPH

FIGURE NO.

TABLE NO.

IN THIS SPACE TELL WHAT IS WRONG AND WHAT SHOULD BE DONE ABOUT IT:

TEAR ALONG PERFORATED LINE

PRINTED NAME, GRADE OR TITLE, AND TELEPHONE NUMBER

SIGN HERE:

DA FORM 2028-2  
JUL 79

PREVIOUS EDITIONS ARE OBSOLETE.

P.S.—IF YOUR OUTFIT WANTS TO KNOW ABOUT YOUR RECOMMENDATION MAKE A CARBON COPY OF THIS AND GIVE IT TO YOUR HEADQUARTERS.

